

JUE-501/JUE-251

**INMARSAT FleetBroadband FB500/FB250
Maritime Satellite Communication Terminal**

**INSTRUCTION
MANUAL**

JRC *Japan Radio Co., Ltd.*

ABOUT YOUR SAFETY

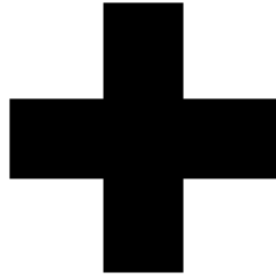

CAUTIONS AGAINST HIGH VOLTAGE

Radio and radar devices are operated by high voltages of anywhere from a few hundred volts up to many hundreds of thousands of volts. Although there is no danger with normal use, it is very dangerous if contact is made with the internal parts of these devices. (Only specialists should attempt any maintenance, troubleshooting, or adjustments.)

There is a very high risk of death by even a few thousand volts, in some cases you can be fatally electrocuted by just a few hundred volts. To circumvent accidents, you should avoid contact with the internal parts of these devices at all costs. If contact is inevitable as in the case of emergency, you must switch off the devices and ground a terminal in order to discharge the capacitors. After making certain that all the electricity is discharged, only then can you insert your hand into the device.

Wearing cotton gloves and putting your free hand in your pocket, in order not to use both hands simultaneously, is also a very good method of shock prevention. Quite often, an injury occurs by secondary factors, therefore it is necessary to choose a sturdy and level working surface. If someone is electrocuted it is necessary to thoroughly disinfect the affected area and seek medical attention as soon as possible.

CAUTIONS CONCERNING TREATMENT OF ELECTROCUTION VICTIMS

When you find an electrocution victim, you must first switch off the machinery and ground all circuits. If you are unable to cut off the machinery, move the victim away from it using a non-conductive material such as dry boards or clothing.

When someone is electrocuted, and the electrical current reaches the breathing synapses of the central nervous system inside the brain, breathing stops. If the victim's condition is stable, he or she can be administered artificial respiration. An electrocution victim becomes very pale, and their pulse can be very weak or even stop, consequently losing consciousness and becoming stiff. Administration of first aid is critical in this situation.

FIRST AID

☆Note points for first aid

Unless there is impending danger leave the victim where he or she is, then begin artificial respiration. Once you begin artificial respiration, you must continue without losing rhythm.

- (1) Make contacts with the victim cautiously, there is a risk that you may get electrocuted.
- (2) Switch off the machinery and then move the victim away slowly if you must.
- (3) Inform someone immediately (a hospital or doctor, dial emergency numbers, etc.).
- (4) Lay the victim on his or her back and loosen any constructive clothing (a tie, or belt).
- (5)
 - (a) Check the victim's pulse.
 - (b) Check for a heartbeat by pressing your ear against the victim's chest.
 - (c) Check if the victim is breathing by putting the back of your hand or face near the victim's face.
 - (d) Check the pupils of the eyes.
- (6) Open the victim's mouth and remove any artificial dentifrice, food or chewing gum. Leave the mouth opened and flatten the tongue with a towel or by putting something into the mouth to prevent the victim's tongue from obstructing the throat (If he or she is clenching their teeth and it is difficult to open the mouth, use a spoon or the like to pry open the mouth).
- (7) Continually wipe the mouth to prevent the accumulation of saliva.

☆If the victim has a pulse but is not breathing

- (1) Place the victim's head facing backward (place something under the neck like a pillow).
- (2) Point the chin upward to widen the trachea.
- (3) Pinch the victim's nose, take a deep breath, then put your mouth over the victim's mouth and exhale completely, making sure that your mouth completely covers the victim's mouth. Then remove your mouth. Repeat this routine 10 to 15 times per minute (holding the nostrils).
- (4) Pay attention to the victim to notice if he or she starts to breath. If breathing returns, stop resuscitation.
- (5) If it is impossible to open the victim's mouth, put something like a plastic straw or vinyl tube into one of the nostrils then blow air in while covering the mouth and the other nostril.
- (6) Occasionally, when the victim comes back to consciousness, they immediately try to stand up. Prevent this and keep them in a laying position. Give them something warm to drink and be sure that they rest (do not give them any alcohol).

Administering artificial respiration by raising the head.

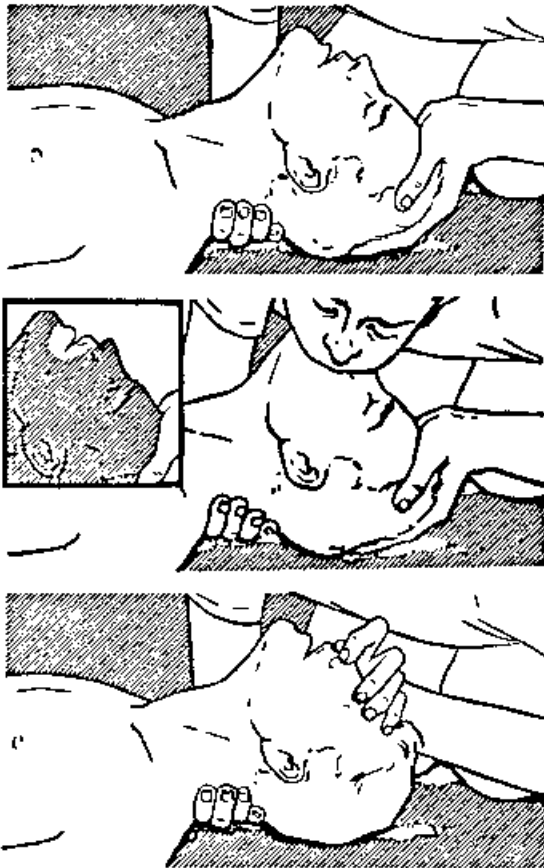

1 Raise the back of head, and then place one hand on the forehead and place the other hand under the neck. **(1)** Most victims open their mouth when doing this, making "mouth to mouth" resuscitation easier.

2 Cover the victim's mouth by opening your mouth widely, then push your cheek against the victim's nose, **(2)** or pinch the victim's nose to prevent air from leaking out of it. **(3)**

3 Completely exhale into the lungs. Exhale into the lungs until the chest is inflated. You have to blow as rapidly as possible the first 10 times.

**"Mouth to mouth" artificial respiration
Figure 1**

☆If the victim has no pulse and is not breathing

If the victim has no pulse, his or her pupils are dilated, and if you cannot detect a heartbeat, the heart may have stopped; beginning artificial respiration is critical.

(1) Put both hands on the diaphragm, with hands on top of it and keeping both arms straight each other (If your elbows are bent; you cannot push with as much power). Press the diaphragm with your body weight until the chest sinks about 2 cm (about 50 times per minute).

(2) If administering first aid when alone:

Perform the heart massage about 15 times then administer artificial respiration by blowing in twice. Repeat this routine.

If administering first aid with two people:

One person performs the heart massage 15 times, and the other person blows air in twice. Repeat this routine (Heart massage and “mouth to mouth” resuscitation used together).

(3) Constantly check the pupils and the pulse, if the pupils become normal and the pulse steadies, keep him in a laying position and give him something warm to drink, be sure that he rests (do not give him any alcohol). In any case you have to entrust any major decision making to a doctor. Having understanding people around is essential to the victim’s recovery from the mental shock of electrocution.

1

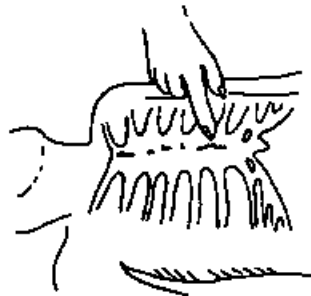

2



3



4

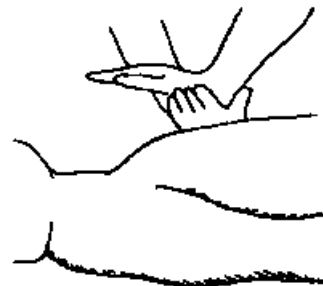

Figure 2 Heart massage in combination with artificial respiration.

PREFACE

Thank you for purchasing the JRC Inmarsat FleetBroadband Mobile Earth Station, the JUE-501/JUE-251.

The JUE-501/JUE-251 is an Inmarsat digital satellite communication terminal for Voice (4kbps Voice), Audio (64kbps 3.1kHz Audio), (*)UDI/RDI, maximum 432kbps(JUE-501) or 284kbps(JUE-251) Standard IP service, 8kbps, 16kbps, 32kbps,64kbps, 128kbps and (*)256kbps Streaming IP service and Short Message Service (SMS).

(*) is available only for JUE-501.

The JUE-501/JUE-251 is packaged and shipped under strict quality control with inspection criteria to deliver the equipment with highest quality, performance, and reliability needed to meet our customer's requirements and satisfaction.

JRC believes that you will use this equipment satisfactorily for a long time.

- Please read this manual carefully and carry out proper operation.
This Manual describes a function and specification based on BDE-App 1.03.
- Please do not lose this useful manual, as you will have to refer to it from time to time.



JUE-501/JUE-251 is manufactured in consideration of effects on environment.

BEFORE OPERATION



(1) About this instruction manual

Before operating this equipment, read the manual carefully to ensure correct instruction. This book is useful for troubleshooting, too.

(2) Concerning the symbols

This manual uses the following symbols to explain the correct operation and to help prevent injury or damage to property.

The symbols and descriptions are as follows. Understand them before proceeding with this manual.

 DANGER	Indicates danger that, if ignored, will result in serious injury or even death.
 WARNING	Indicates warning that, if ignored, may result in serious injury or even death.
 CAUTION	Indicates caution that, if ignored, may result in injury or damage to property.

Examples of symbols



The \triangle symbol indicates caution (including DANGER and WARNING). The illustration inside the \triangle symbol specifies the content of the caution more accurately. (This example warns of possible electrical shock.)



The \circ symbol indicates that performing an action is prohibited. The illustration inside the \circ symbol specifies the content of the prohibited operation. (In this example disassembly is prohibited.)



The \bullet symbol indicates operations that must be performed. The illustration inside the \bullet symbol specifies obligatory instructions. (In this example unplugging is obligatory.)

(3) Concerning warning labels

Warning labels are posted on the equipment. Do not remove, damage or modify.

* Windows Internet Explorer is a registered trademark of Microsoft Corporation.

Firefox is a registered trademark of Mozilla Foundation.

Concerning warning label

Warning labels are put on the JUE-501/JUE-251 ADE and BDE.

Do not take off, destroy, or modify these labels.

<Warning Label of JUE-501 ADE>

(The illustration of upper part shows the safety Procedure for removing Radome from ADE.)

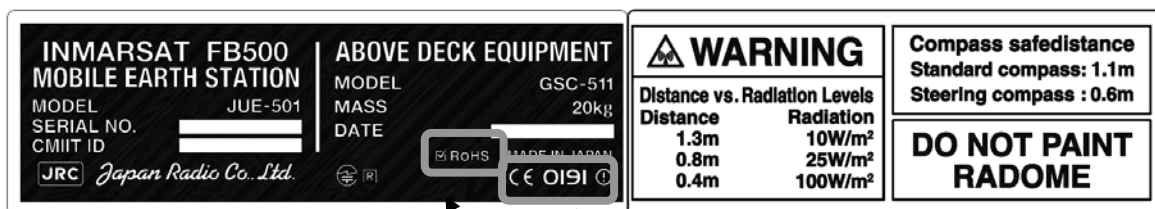
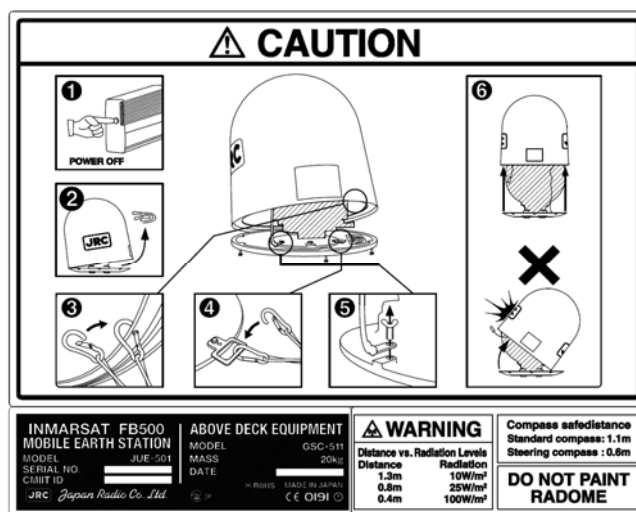

Note 1) Note 3)

<Warning Label of JUE-251 ADE>

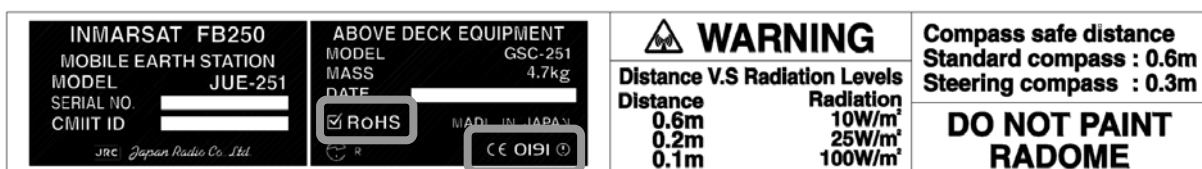

Note 1) Note 3)

<Warning Label of JUE-501 BDE>

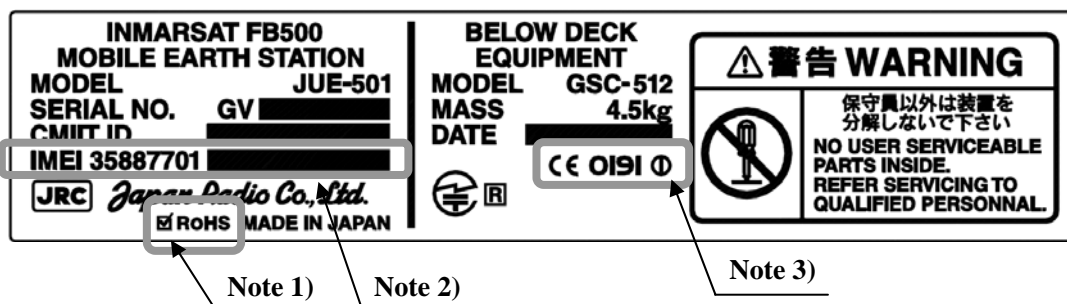

<Warning Label of JUE-251 BDE>

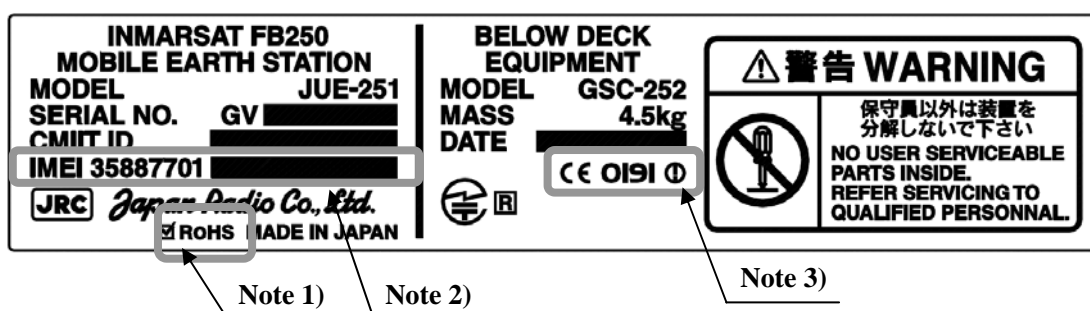

Notes

- 1) This mark means this equipment clears the directive of Restricting the use of Hazardous Substances (RoHS).
- 2) This mark, International Mobile Equipment Identity (IMEI) is an unique number used to identify an individual mobile equipment to a GSM or UMTS network.
- 3) This mark means the attestation number which means safe, high-quality product and suits EU instruction (Free circulation was permitted in the EU signatory).

BEFORE USING

- JRC is indemnified for any damages from incorrect operation, malfunction, and other troubles except as outlined in the product warranty and by limitation of law.
- Some functions of JUE-501/JUE-251 may not work correctly owing to the hardware and software version of equipment connected to JUE-501/JUE-251. Please confirm that whether your equipment is connectable or not to the dealer or agent.
- Your communication data are transmitted via the Inmarsat systems, therefore, there is a possibility that some errors may occur.

We strongly recommend important data be backed up to ensure safety and protection from loss.

Usually, digital scrambling of the Inmarsat system protects your communication data privacy. However we caution you to understand that your communication data might be intercepted by special technology and unauthorized access to the communication theory.

There are some additional and optional functions of the JUE-501/JUE-251 that shall be released in the near future for evaluation.

- Specifications of the JUE-501/JUE-251 and its accessories may change without notice, for improvement.
- Some functions may not be supported by a product version.

Please contact JRC for more information.

DURING OPERATION

DANGER



Do not touch any internal parts with your hands or tools.
It may cause fire, electrical shock or malfunction.

WARNING



Please do not bring the power supply code close to the heat apparatus.
The coating of the code may be relieved, and it causes a fire and the electric shock.



Keep out of the area within a radius of described below from your ADE
respectively, while transmitting. It transmits microwave and strong microwave
may cause injury.

[JUE-501]

Radiation Level	Distance
10W/m ²	1.3m
25W/m ²	0.8m
100W/m ²	0.4m

In case of approach within a radius of 1.3meters by necessity, turn off the
JUE-501 and stop transmitting.

[JUE-251]

Radiation Level	Distance
10W/m ²	0.6m
25W/m ²	0.2m
100W/m ²	0.1m

In case of approach within a radius of 0.6meters by necessity, turn off the
JUE-251 and stop transmitting.



If an external matter, such as metal fragments, water, liquid, etc., infringes into
your JUE-501/JUE-251, turn off the power and contact the dealer or agent you
purchased the equipment from. Continuous operation may cause fire, electrical
shock or malfunction.

WARNING



Install the JUE-501/JUE-251 correctly in accordance with the installation manual. Inappropriate installation may cause incorrect operation; fire, electrical shock, or malfunction. The JUE-501/JUE-251 should be installed by the trained technician or engineer. The installation should be requested to the purchasing dealer, JRC agent or one of the JRC branches.



Install ADE-BDE coaxial cable correctly in accordance with the Installation manual. Especially waterproof should be treated correctly in accordance with the installation manual. Inappropriate installation may cause incorrect operation, fire, electric shock or malfunction. The installation has to be carried out under the supervision of trained technician or field engineer.



Use the specified power supply voltage only (+21VDC to +31VDC), otherwise trouble, fire, or electric shock or malfunction may occur.



Do not troubleshoot or repair the internal equipment of the JUE-501/JUE-251 by yourself. Any electrical work by any person other than our trained maintenance staff may cause fire or abnormal operation of this equipment or electrical shock for you. This equipment meets the technical standard of the Ministry of Internal affairs and Communications.



Do not adjust the internal circuit without a calibrated measuring instrument or exchange the parts because the internal circuit has been adjusted finely to specifications. If the equipment works abnormally, please contact the purchasing dealer.



Do not remove, destroy, or modify warning labels. It may cause poor hazard prevention.

CAUTION



Before using, read this instruction manual.
Incorrect operation may cause improper working operation or malfunction.



When a fault has been detected, refer to the “Appendix L. Trouble shooting and FAQ”. If it is not improved, turn OFF and ON the power switch of main unit to reboot. Still it persists, stop operation and contact the dealer you purchased from.

<<Above Deck Equipment>>



Do not deliver mechanical shock and/or force, because each unit of your ADE is a precision instrument. Unwanted shock and force may cause malfunction.



Do not paint the radome. Painting of the radome may cause a decrease of the communication quality.

<<Below Deck Equipment>>



Do not mount the Handset near CRT device or other devices; otherwise performance of the devices may be affected by the Handset’s magnetic field.



Do not set/remove the SIM card during power switch is turned on.
It may cause malfunction.



Do not set/remove the ADE-BDE cable during power switch is turned on.
It may cause malfunction.



Do not remove the power supply cable before the power source disconnecting process is completed. It may cause malfunction.

<<Coaxial Cable and the other cables>>



Take care not to damage the connectors and the corrosion resistant sheath of cable. Otherwise, a trouble may occur.



Do not pull the cable by gripping connector plug only.
Otherwise, a trouble may occur.

Emergency Calling

(1) About 505 Emergency Calling

Inmarsat has introduced 505 Emergency Calling for the FBB terminals.

In a time of distress, a seafarer need only dial "505" and press either the offhook () or # key- selected for its similarity to "SOS" - to immediately contact a Maritime Rescue Co-ordination Centre (MRCC).

Please note that **505 Emergency Calling is NOT GMDSS compliant**. 505 Emergency Calling can not be used if other phone or fax is used. Finish using phone and fax before dialing "505".

505 **Emergency Calling**
for FleetBroadband 

In an emergency, call **505** and press either the  or # key on the handset. You will be connected to a Maritime Rescue Coordination Centre.

Speak slowly and clearly and provide the following information:

Who you are: vessel name, telephone number and callsign

Where you are: your position in latitude and longitude or a bearing and distance from a known geographical point

What is wrong: nature of emergency or difficulty

Type of assistance required

Number of persons on board

Please do not abuse this service. Only use 505 if you need urgent assistance.
Please note that 505 Emergency Calling is not GMDSS compliant.

This page is remained as a blank.

Inmarsat FleetBroadband JUE-501/JUE-251 Instruction Manual

Contents

PREFACE	v
BEFORE OPERATION	vi
BEFORE USING	ix
DURING OPERATION.....	x
Emergency Calling.....	xiii
1. The Inmarsat Service systems.....	1-1
1.1 Outline.....	1-1
1.1.1 Coverage area.....	1-1
1.1.2 The Inmarsat FleetBroadband System	1-2
1.2 The Inmarsat Fleet Broadband services.....	1-3
1.3 Important reminder for using JUE-501/JUE-251	1-4
1.4 Emergency Calling.....	1-5
1.4.1 505 Emergency Calling.....	1-5
2. Introduction of the JUE-501/JUE-251	2-1
2.1 Outline.....	2-1
2.2 Features	2-2
2.3 Cable connection system diagram and components List	2-3
2.3.1 Cable connection system diagram	2-3
2.3.2 Components list	2-4
2.4 Dimensional drawing (JUE-501/JUE-251 standard components).....	2-5
2.4.1 ADE (Above Deck Equipment)JUE-501[GSC-511]	2-5
2.4.2 ADE (Above Deck Equipment)JUE-251[GSC-251]	2-6
2.4.3 BDE (Below Deck Equipment) JUE-501 [GSC-512]	2-7
2.4.4 BDE (Below Deck Equipment) JUE-251 [GSC-252]	2-8
2.4.5 Handset [NQW-267]	2-9
2.4.6 Junction Board [CQD-2243]	2-10
2.4.7 Coaxial cable [CFQ-3922A5/5984A3].....	2-11
3. Appearance	3-1
3.1 ADE	3-1
3.2 BDE.....	3-2
3.3 ADE—BDE connecting cable	3-5
3.4 Handset	3-6
3.4.1 LCD/LED section	3-7
3.4.2 Functional button section.....	3-12
3.4.3 Alpha-Numeric button section.....	3-12

3.5	Communication terminals.....	3-13
3.5.1	Terminal requirements	3-13
3.5.2	Usage environment	3-14
3.6	Handset menu.....	3-14
4.	Getting started.....	4-1
4.1	Connecting terminals and power on	4-2
4.1.1	Connecting terminals with cables	4-2
4.1.2	Setting/removing SIM card.....	4-4
4.1.3	Power ON.....	4-6
4.1.4	Screen display of Handset.....	4-8
4.2	Initial setting for communication	4-10
4.2.1	Mode setting of Guest and Admin	4-11
4.2.2	Setting outgoing service type.....	4-12
4.2.3	Setting incoming service type.....	4-13
4.2.4	Setting satellite search.....	4-14
5.	How to use the Telephone/FAX.....	5-1
5.1	Handset	5-6
5.1.1	Making/ Answering an outside call.....	5-6
5.1.2	Using Phonebook (Speed dial).....	5-7
5.1.3	Using Redial menu.....	5-8
5.1.4	Adjusting voice volume, backlight brightness, and ringer volume	5-9
5.1.5	Adjusting ringer volume/pattern/voice volume/backlight brightness (Admin user only).....	5-10
5.1.6	Calling Internal Phone	5-12
5.1.7	Forwarding a call from Handset to terminal telephone	5-13
5.1.8	Handling Call Waiting.....	5-15
5.1.9	Holding on the line.....	5-16
5.1.10	Rejecting Incoming/Outgoing call (call barring).....	5-17
5.1.11	Displaying voice mail service number.....	5-18
5.1.12	Using a Secret Code.....	5-19
5.1.13	Entry, change and deletion of Phonebook	5-21
5.1.14	Displaying Call Log.....	5-24
5.1.15	Restricting Outgoing Call (Admin user only)	5-27
5.1.16	Setting Call-Sound for Incoming Call (Admin user only).....	5-28
5.2	Using telephone/FAX with TEL port.....	5-29
5.2.1	Dial-up procedure	5-29
5.2.2	Calling Internal Phone	5-32
5.2.3	Forwarding a call to the other terminals	5-33

5.2.4	Handling Call Waiting	5-34
5.2.5	Holding on the line	5-34
6	Web Menu System	6-1
6.1	Connect Your PC to JUE-501/JUE-251	6-2
6.2	Web Screen	6-6
6.3	Login/Logout	6-8
6.4	Menus for all Users	6-10
6.4.1	Dashboard (Dashboard Screen)	6-10
6.4.2	Connect to the Internet (Data Connection Screen).....	6-14
6.4.3	SMS Menus	6-16
6.4.3.1	SMS New Message (New Message Screen).....	6-17
6.4.3.2	SMS Inbox (Inbox Screen).....	6-18
6.4.3.3	SMS Sent box (Sent Screen).....	6-19
6.4.3.4	SMS Draft box (Draft Screen).....	6-20
6.4.3.5	SMS Setting (Setting Screen)	6-21
6.4.4	Phonebook (Phonebook Screen).....	6-22
6.4.5	Call Log Menus	6-23
6.4.5.1	Check Call Log (Call Log Screen).....	6-23
6.4.5.2	Set Call Charge Rate (Call Charge Screen)	6-25
6.4.6	System Log Menus	6-26
6.4.6.1	Check Alarmpack (Alarmpack Screen).....	6-26
6.4.6.2	Check Event Log (Event Log Screen)	6-31
6.4.6.3	Check ADE (ADE Monitor Screen)	6-32
6.5	Menus for Admin Users	6-33
6.5.1	Set Basic Information (Terminal Screen).....	6-33
6.5.2	Telephony Menus	6-34
6.5.2.1	Set up Port (Telephony Screen)	6-34
6.5.2.2	Set Auto Answering the Telephone (PBX Screen).....	6-36
6.5.2.3	Set Telephone Supplementary Service (Supplementary Screen). 6-37	
6.5.3	Port Menus.....	6-39
6.5.3.1	Set Handset (Handset Screen).....	6-39
6.5.3.2	Set MSN and ISDN Service Type (ISDN Screen).....	6-40
6.5.3.3	Set User LAN and EXT WAN (Ethernet Screen)	6-41
6.5.3.4	Set Input/Output Signal (I/O Screen).....	6-43
6.5.3.5	Set Option Button and Buzzer (Option Screen).....	6-44
6.5.4	User Control Menus.....	6-45
6.5.4.1	Register Users (User Registration Screen)	6-45
6.5.4.2	Register Devices (Device Registration Screen)	6-47
6.5.4.3	Restrict User Connection (Usage Restriction Screen).....	6-48
6.5.5	Network Menus	6-49

6.5.5.1	Set WAN Profile (WAN Profile Screen)	6-50
6.5.5.2	Set Packet Filter (Packet Filter Screen)	6-57
6.5.5.3	Set Permanent Connection (Always Activate Screen).....	6-60
6.5.5.4	Establish Remote Connection (Remote Activate Screen)	6-62
6.5.5.5	Set LAN Group (LAN Group Screen).....	6-64
6.5.5.6	Further Settings for User LAN (LAN Screen).....	6-66
6.5.5.7	Use Static IP Address (Static DHCP Screen).....	6-68
6.5.5.8	Set Routing Table (Routing Table Screen).....	6-70
6.5.5.9	Coexistence with Other WAN (WAN Selector Screen)	6-71
6.5.6	Disconnect Automatically by Time (Auto Disconnect Screen).....	6-72
6.5.7	Configure SIM (SIM Screen)	6-73
6.5.8	File Export/Import (Export / Import Screen)	6-75
6.5.9	Reset to Factory Default (Factory Default Screen)	6-75
6.5.10	Update Software (Software Update Screen)	6-76
6.5.11	Perform Diagnostic Test (Diagnostic Screen)	6-77
7.	Handset Menu System	7-1
	TOP menu	7-3
7.1.	Status menu	7-4
7.1.1	RX (Reception) menu	7-5
7.1.2	TX (Transmission) menu	7-5
7.1.3	Position status display.....	7-6
7.1.4	Product menu	7-7
7.1.5	Unit Info menu	7-8
7.1.6	ID menu	7-12
7.2	SMS menu.....	7-13
7.2.1	New Msg menu	7-15
7.2.2	Inbox menu	7-17
7.2.3	Sent menu.....	7-18
7.2.4	Draft menu	7-19
7.2.5	Setting menu	7-20
7.3	Satellite menu.....	7-21
7.3.1	Satellite selection	7-21
7.3.2	Spot Beam ID display	7-21
7.4	Phonebook (Speed dial) menu	7-22
7.4.1	Editing the Phonebook address.....	7-23
7.5	Redial menu	7-24
7.6	Internal menu	7-25
7.7	Call Log (Communication history) menu	7-26
7.7.1	Call Log list menu.....	7-27
7.7.2	Call Log authentication and deletion	7-29

7.7.3	Setting telecom rates	7-30
7.8	Alarmpack menu	7-31
7.8.1	Unit selection menu for Alarm Pack.....	7-32
7.9	Admin menu.....	7-35
7.9.1	Terminal menu	7-36
7.9.1.1	Delivery setting.....	7-37
7.9.1.2	Local Time setting	7-38
7.9.1.3	Tracking setting.....	7-39
7.9.1.4	GPS Input setting.....	7-40
7.9.1.5	VDR Output setting.....	7-41
7.9.1.6	WRF setting.....	7-42
7.9.1.7	Panel LED setting.....	7-43
7.9.1.8	Ether LED setting	7-43
7.9.1.9	Block. Ind. setting.....	7-44
7.9.2	Telephony menu.....	7-45
7.9.2.1	Telephony setting	7-46
7.9.2.2	PBX setting.....	7-49
7.9.2.3	Suppl. setting	7-50
7.9.3	Port menu	7-52
7.9.3.1	Handset advanced setting.....	7-53
7.9.3.2	ISDN MSN setting.....	7-54
7.9.3.3	Ethernet (User LAN / EXT WAN)setting	7-55
7.9.3.4	I/O setting	7-57
7.9.3.5	Option setting	7-58
7.9.4	User Cont. menu	7-59
7.9.4.1	User Reg. setting.....	7-60
7.9.4.2	Usage Rest. setting.....	7-63
7.9.5	Auto Dcn. (Auto disconnection) menu	7-65
7.9.5.1	Max Time setting	7-66
7.9.5.2	Idle Time setting	7-67
7.9.6	SIM menu.....	7-68
7.9.6.1	PIN Mode setting.....	7-69
7.9.6.2	Change PIN setting.....	7-71
7.9.6.3	Facility setting	7-72
7.9.6.4	Secondary SIM setting	7-73
7.9.7	Default menu	7-74
7.9.7.1	Alarmpack	7-75
7.9.7.2	Flash	7-75
7.10	Other screen	7-76
8.	Using ISDN port	8-1

9. Maintenance.....	9-1
10. After-sales service.....	10-1
11. Specification.....	11-1

(APPENDIX)

A Handset menu tree.....	A-1
B Web menu tree.....	B-1
C Junction Board.....	C-1
D Software updating procedure	D-1
E Return to the factory default.....	E-1
F Default value list (BDE-App 01.00).....	F-1
G JUE-501/251 VPN setting.....	G-1
H How to connect PPPoE Connection	H-1
I FB LaunchPad Installation Procedure	I-1
J Use FB LaunchPad.....	J-1
K TCP Accelerator Installation Procedure.....	K-1
L Trouble shooting and FAQ	L-1
M Cause Code.....	M-1
N Front Panel LED lamps.....	N-1
O Quick Chart.....	O-1
P Glossary	P-1
Q JRC Network.....	Q-1
R Declaration on toxic & Hazardous substances or elements of Electronic Information Products	R-1

1. The Inmarsat Service Systems	1
2. Introduction of the JUE-501/JUE-251	2
3. Appearance	3
4. Getting Started	4
5. How to use the Telephone / FAX	5
6. Web Menu System	6
7. Handset Menu System	7
8. Using ISDN port	8
9. Maintenance	9
10. After-sales service	10
11. Specification	11

APPENDIX

1. Inmarsat Service systems

1.1 Outline

1.1.1 Coverage area

The Inmarsat Satellites cover the earth's surface except at the high latitude areas near the North Pole and the South Pole.

Inmarsat terminals are available for any type of vehicle or ship, and are capable of communicating day and night.

The Inmarsat coverage map displays the area of three satellite regions

- **Europe, Middle East, Africa (EMEA) Ocean Region**
- **Asia-Pacific (APAC) Ocean Region**
- **Americas (AMER) Ocean Region**

A geostationary satellite is placed on each Ocean Region (excluded spare satellites).

The adjacent Ocean Regions have overlapped area of satellite regions. Suitable Ocean Region (satellite region) is automatically selected when JUE-501/JUE-251 positions in overlapped area.

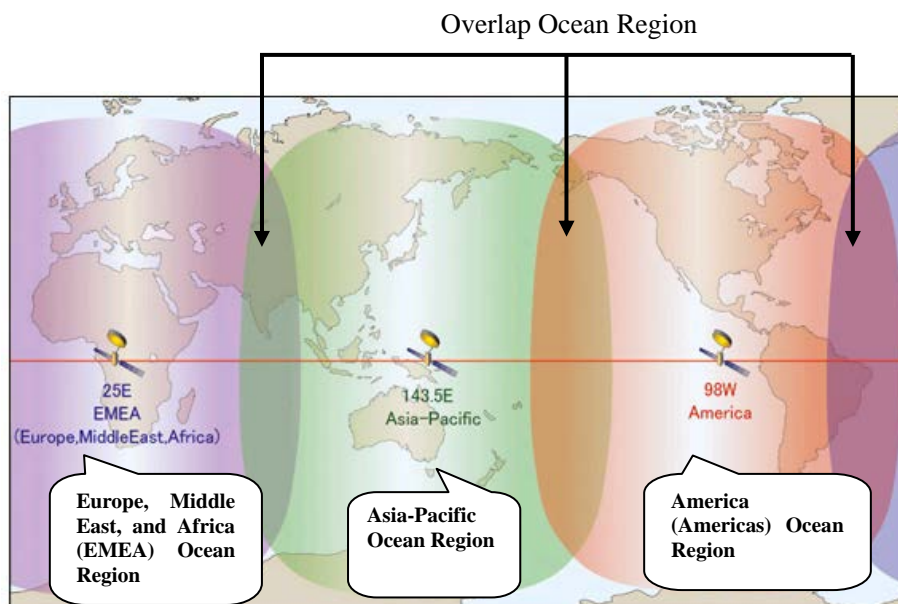

Fig.1.1.1 The coverage areas of Ocean Region

1.1.2 The Inmarsat FleetBroadband System

The Inmarsat network system consists of NCS, NOC, SCC, TT&C, and SAS.

Functions of each facility are as follows:

1) Network Coordination Station (NCS)

The NCS assigns communication channels between the Mobile Earth Stations (MES) and Satellite Access Station (SAS).

2) Network Operation Center (NOC)

The NOC located at the INMARSAT headquarters in London U.K., coordinates communication lines of the network 24 hours a day, 365 days a year. The NOC maintains contact via dedicated satellite and terrestrial links with the NCSs and SASs in all Ocean regions.

The NOC performs the following:

- Coordination with the Satellite Control Center (SCC) for operation of satellites.
- Coordination with NCS and/or SAS for system operation.
- Collection of any status data in operation .
- Coordination of any test of satellite's performance.

3) Satellite Control Center (SCC)

The SCC controls the positioning of the satellites above the equator.

4) Tracking Telemetry and Control Center (TT&C)

The TT&C supplies data on the status of the Inmarsat satellites to SCC.

5) Satellite Access Station (SAS)

The SASs located in Fucino (Italy), Burum (Holland) and Hawaii (America) which are the gateway systems operating inter-working with public network (including telephone and Internet).

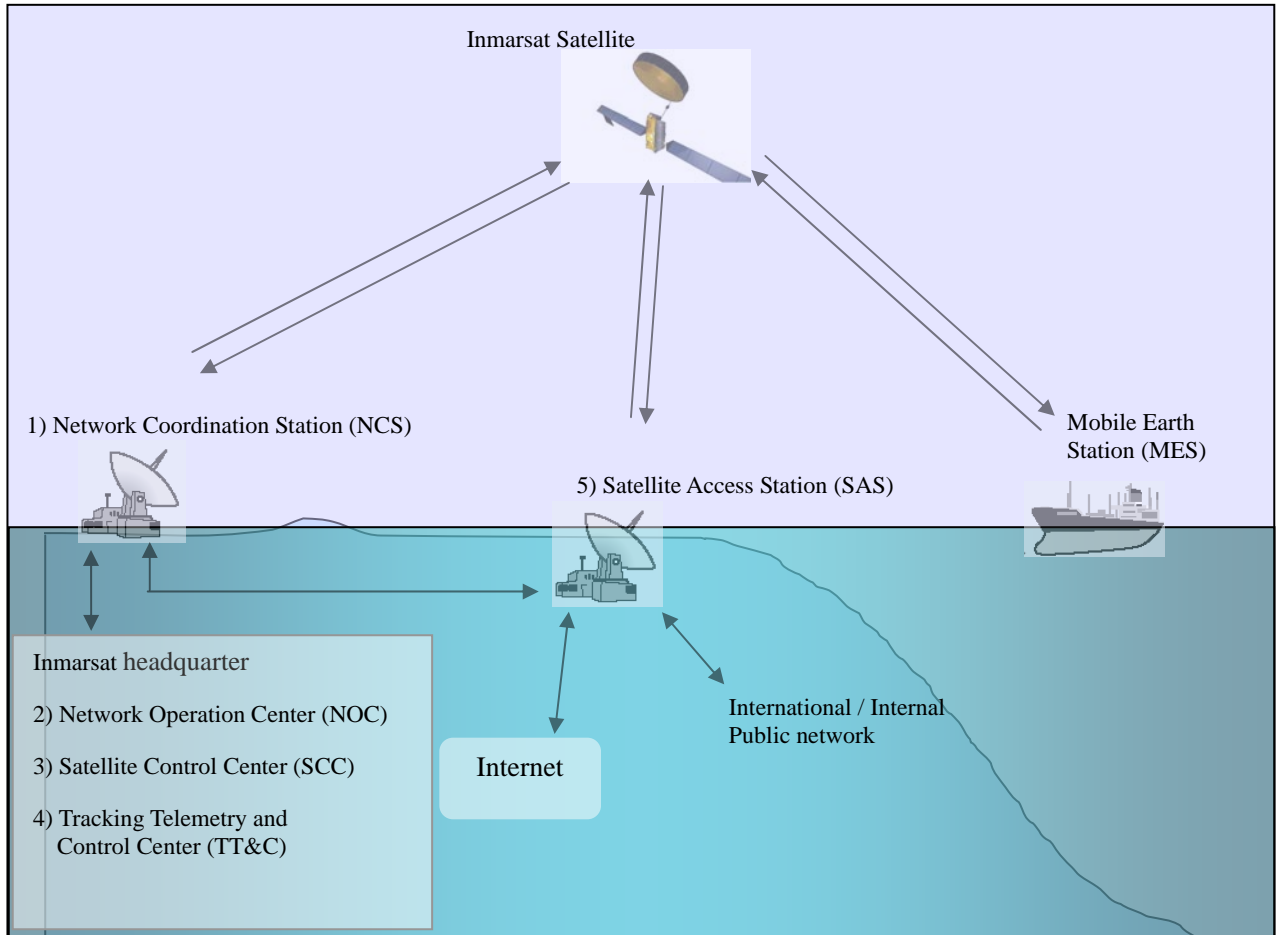

Fig.1.1.2 The Inmarsat FleetBroadband service Network



1.2 The Inmarsat FleetBroadband services

Inmarsat FleetBroadband provides service shown below.

Packet Switched service (PS), Circuit Switched service (CS), and Short Message Service (SMS) can be used simultaneously.



JUE-501/JUE-251 supports a maximum of 11 PS connections and one CS connection at the same time.

Packet switched service (PS)

<p>Standard IP</p> 	<ul style="list-style-type: none"> • Internet and intranet access at speed up to 432kbps over a shared channel for FB500. (Up to 284kbps for FB250.) • Charged by data amount
<p>Streaming IP</p> 	<ul style="list-style-type: none"> • Internet and intranet access at guaranteed data rates on demand up to 256kbps (8, 16, 32, 64, 128 and 256kbps) for FB500. (Up to 128kbps for FB250) • Charged by connection time.

1. Inmarsat Service systems

Circuit switched service (CS)

4kbps Voice 	<ul style="list-style-type: none">• Low cost voice service equal to Inmarsat mini-M voice• Charged by connection time
64kbps 3.1kHz Audio 	<ul style="list-style-type: none">• High quality voice service to use FAX and analogue modem.• Charged by connection time
ISDN UDI/RDI ^{*)} data (Only for FB500) 	<ul style="list-style-type: none">• ISDN 64k/56kbps data service for ISDN video phone, etc.• Charged by connection time

^{*)} UDI = Unrestricted Digital Information
RDI = Restricted Digital Information

Short Message Service (SMS)

Short Message Service 	<ul style="list-style-type: none">• Send and receive text messages up to 160 characters.• Charged by message.
---	--

1.3 Important reminder for using JUE-501/JUE-251

NOTE

- Communication failure due to MCA wireless system interference could occur at the coast of Japan urban area.
- 64kbps 3.1kHz Audio service is not available when satellite elevation angle (EL) value is less than 20 degrees for the JUE-251.
- Although 8k, 16k, 32k, 64k, 128kbps Streaming IP service and CS service can be used in the same time, use of 256kbps Streaming IP and simultaneous CS service is not possible.
- The service available to you is depending on the contract. Some of the services described in this manual may not work for your SIM card.

1.4 Emergency Calling

1.4.1 505 Emergency Calling

Inmarsat has introduced 505 Emergency Calling for the FBB terminals.

In a time of distress, a seafarer need only dial "505" and press either the offhook () or # key-selected for its similarity to "SOS" - to immediately contact a Maritime Rescue Co-ordination Centre (MRCC).

Please note that **505 Emergency Calling is NOT GMDSS compliant**. 505 Emergency Calling can not be used if other phone or fax is used. Finish using phone and fax before dialing "505".

505 Emergency Calling
for FleetBroadband 

In an emergency, call **505** and press either the  or # key on the handset. You will be connected to a Maritime Rescue Coordination Centre.

Speak slowly and clearly and provide the following information:

- Who you are:** vessel name, telephone number and callsign
- Where you are:** your position in latitude and longitude or a bearing and distance from a known geographical point
- What is wrong:** nature of emergency or difficulty
- Type** of assistance required
- Number** of persons on board

Please do not abuse this service. Only use 505 if you need urgent assistance.
Please note that 505 Emergency Calling is not GMDSS compliant.

1. Inmarsat Service systems

This page is remained as a blank.

2. Introduction of the JUE-501/JUE-251

2.1 Outline

The JUE-501/JUE-251 Mobile Earth Station (MES) is composed of Above Deck Equipment (ADE) and Below Deck Equipment (BDE).

The ADE consists of Antenna Assembly, Above Deck Unit and Radome, while the BDE consists of Main Unit (MU) and Handset.

JUE-501/JUE-251 is an Inmarsat digital satellite communication terminal for voice service (4kbps Voice), G3FAX and legacy analogue modem service (64kbps 3.1kHz Audio), (*)UDI/RDI, maximum 432kbps(JUE-501) or 284kbps(JUE-251) Standard IP service, 8kbps, 16kbps, 32kbps,64kbps, 128kbps and (*)256kbps Streaming IP service and Short Message Service (SMS).

[(*) is available only for JUE-501.]

JUE-501/JUE-251 is shipped with strict quality control and inspection to provide the high quality for consumers. JRC would like to believe you to make long use of the terminal with your satisfaction.

If your JUE-501/JUE-251 has trouble or problem in your operation, please contact the dealer or agent you purchased from.

2.2 Features

Meeting the latest FleetBroadband SDM

The JUE-501 meets the latest Inmarsat FleetBroadband FB500 technical requirements (SDM) and JUE-251 also meets the latest Inmarsat FleetBroadband FB250 technical requirements (SDM). They are suitable solutions for satellite communications equipment for any type of vessel, navigating the world's oceans.

High quality and low communication cost

The JUE-501/JUE-251 provides following services using Broadband Global Area Network (BGAN) offered from Inmarsat.

- Low cost global voice service: 4kbps Voice
 - G3FAX and legacy analogue modem service using 64kbps 3.1kHz Audio service (unavailable for the JUE-251 when satellite elevation angle (EL) value is less than 20 degrees)
 - Standard IP service at speed up to 432kbps over a shared channel (Up to 284kbps for JUE-251)
 - Streaming IP service (8k, 16k, 32k, 64k, 128k, and 256kbps) (Up to 128kbps for JUE-251)
 - UDI/RDI service (unavailable for JUE-251)
 - SMS (maximum number of characters are 160)
- * The service available to you is depending on the contract.

Stylish, Light weight, Space-saving, and Gyro-less

The JUE-501/JUE-251 can be installed on vessels of all sizes due to the compact and lightweight design of the ADE. The adoption of an active and Gyro-less antenna structure makes this unit a perfect fit for small vessels.

With the use of a single coaxial cable as the control line between the ADE and BDE the installation of the JUE-501/JUE-251 is simple and easy.

The Rewindless antenna produces uninterrupted communication during course change.

Adaptive to various networks

The JUE-501/JUE-251 has multiple Interfaces including Ethernet, ISDN, 2TEL ports (maximum 6 TEL ports)*, and Handset as standard equipment. An output port for WRF (Wide-band Radio Frequency) is also provided.

*Standard equipment provides 2 telephones, and 4 more telephones can be connected when connecting Junction Board (JB), as optional equipment.

Self-diagnosis system

The built-in self-diagnosis system continually monitors the status of the JUE-501/JUE-251 and indicates the warnings if any errors are detected.

2.3 Cable connection diagram and components List

2.3.1 Cable connection diagram

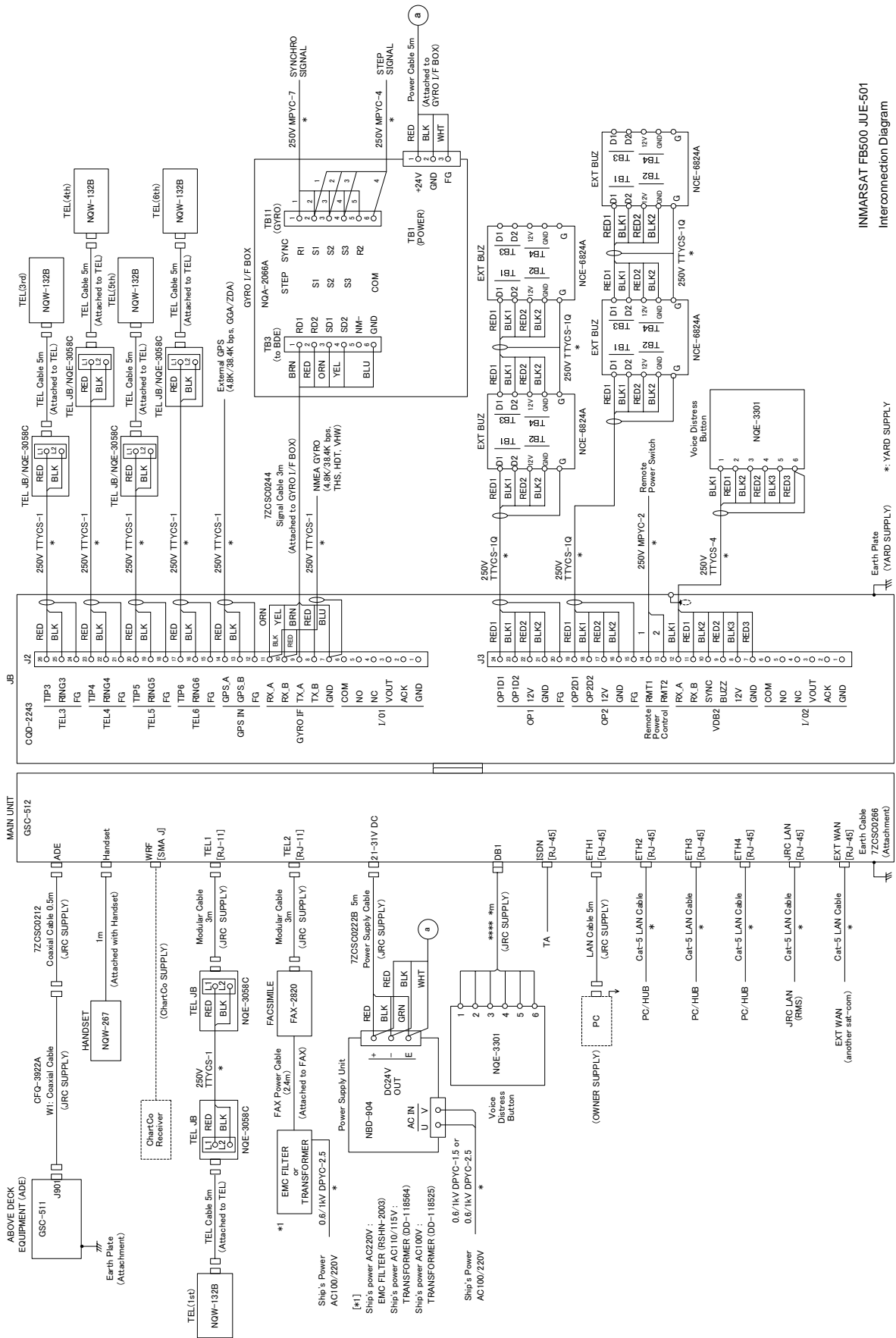

Fig. 2.3.1 Cable connection diagram (JUE-501)

2. Introduction of JUE-501/JUE-251

2.3.2 Components list

Table 2.3.2 Components list

	Name of equipment		Type	Q'ty
Standard Components	ADE	JUE-501	GSC-511	1
		JUE-251	GSC-251	1
	BDE	JUE-501	GSC-512	1
		JUE-251	GSC-252	1
	Handset		NQW-267	1
	PSU cable (between EXT PSU and BDE main unit)		7ZCSC0222B	1
	Instruction Manual		7ZPSC0427	1
	Installation Manual		7ZPSC0429	1
	Quick Reference Guide		7ZPSC0431	1
	CD-ROM		7ZPSC0433	1
	Supplied parts for ADE installation	JUE-501	MPXP34916	1
		JUE-251	MPXP34915	1
	Supplied parts for BDE installation		7ZXSC2502	1
	Spare parts (fuse for BDE)		7ZXSC0008	3
	Option	Coaxial cable (between ADE and BDE)	JUE-501	CFQ-3922A5* (50m)
JUE-251			CFQ-5924A3** (30m)	1
Relay cable (between CFQ-3922A/3923A and BDE main unit)		7ZCSC0212	1	
Junction Board		CQD-2243	1	
Telephone		NQW-132B	1	
Facsimile (brother FAX-2820)		7EZSC0060	1	
Power transformer for Facsimile (For AC100V)		DD-118525	1	
Power transformer for Facsimile (For AC110V/115V)		DD-118564	1	
EMC Filter for facsimile (For AC230V direct coupling)		RSHN-2003	1	
External Power supply Unit (EXT PSU)		NBD-904	1	
Telephone Junction Box (TEL JB)		NQE-3058C	2	
Handset extension cable		7ZCSC0291	1	
GYRO I/F BOX		NQA-2066A***	1	
External buzzer		NCE-6824A	Max 4	
Voice distress button		NQE-3301	Max 2	

*CFQ-3922A series (15m to 45m, 5m interval, 5D), CFQ-3923A series (70m and 100m, 10D) are available as options.

**CFQ-5924A15 (15m), CFQ-3922A series (35m to 50m, 5m interval, 5D) and CFQ-3923A series (70m and 100m, 10D) are available as options.

***SYNC/STEP GYRO requires GYRO I/F BOX.

2.4 Dimensional drawing (JUE-501/JUE-251 standard components)

2.4.1 ADE (Above Deck Equipment) JUE-501[GSC-511]

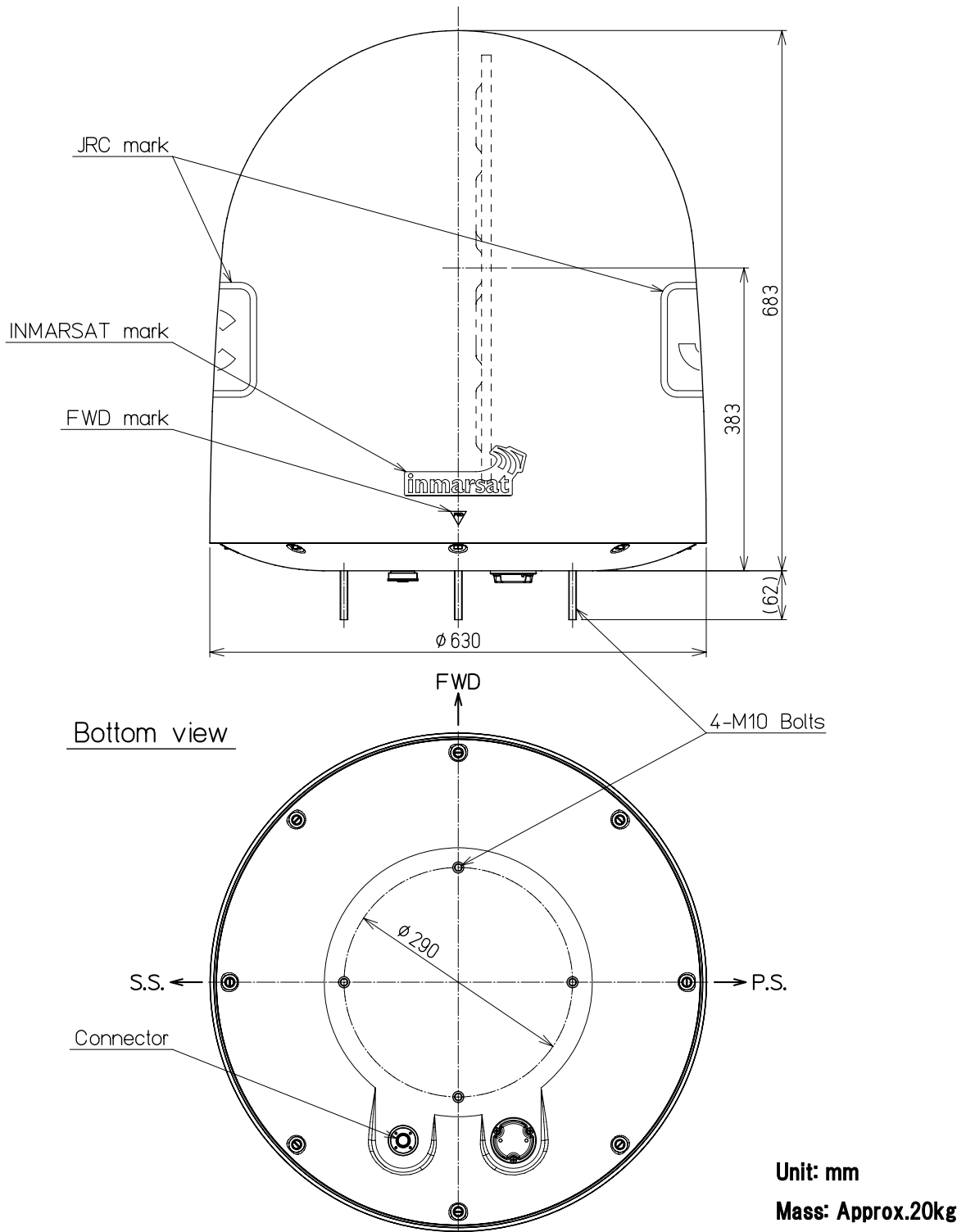

Fig. 2.4.1 Appearance of JUE-501 ADE (GSC-511)

2.4.2 ADE (Above Deck Equipment) JUE-251[GSC-251]

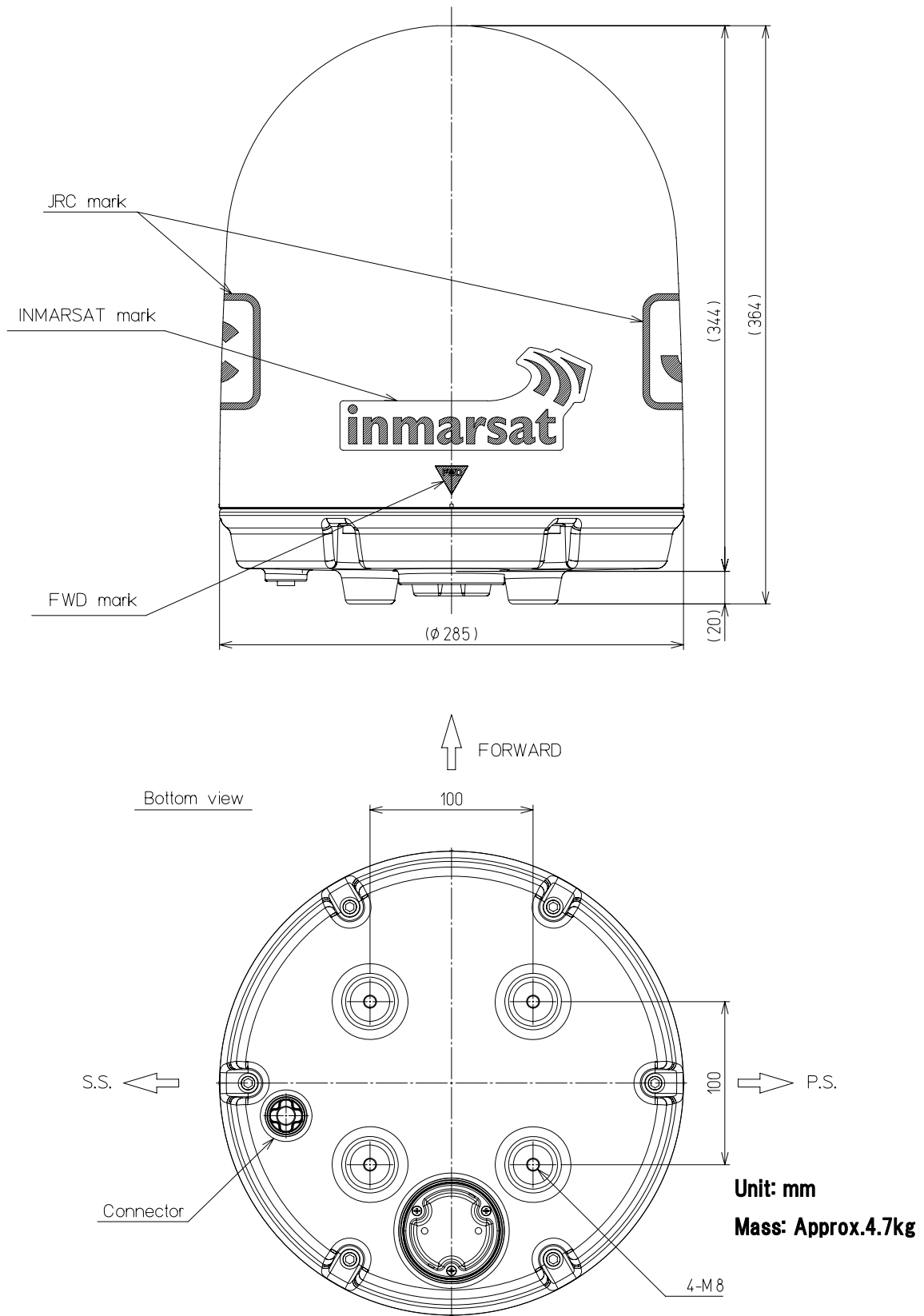
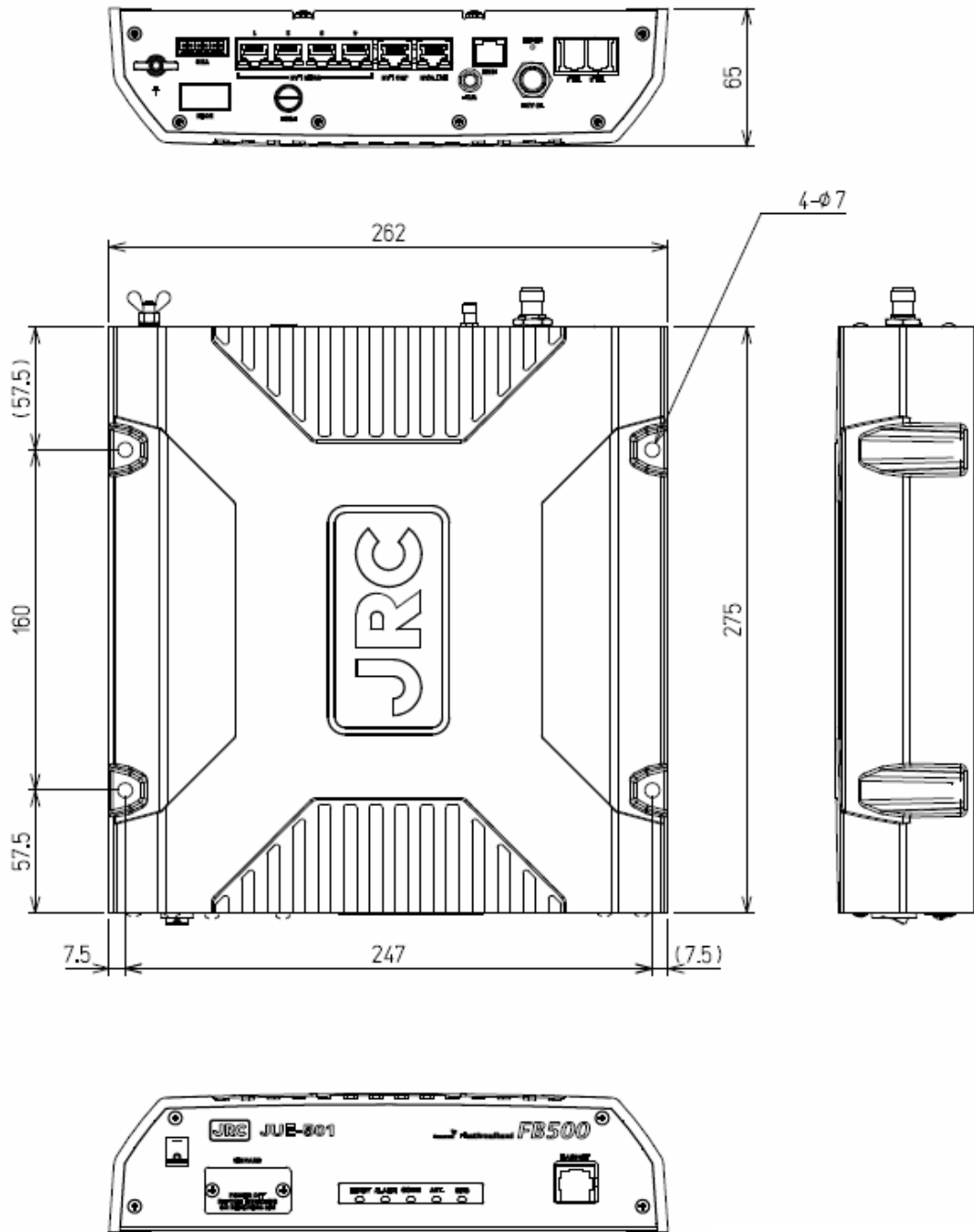

Fig. 2.4.2 Appearance of JUE-251 ADE (GSC-251)

2.4.3 BDE (Below Deck Equipment) JUE-501[GSC-512]



Unit: mm

Mass: approx. 4.5kg

Fig. 2.4.3 Appearance of JUE-501 BDE (GSC-512)

2.4.4 BDE (Below Deck Equipment) JUE-251[GSC-252]

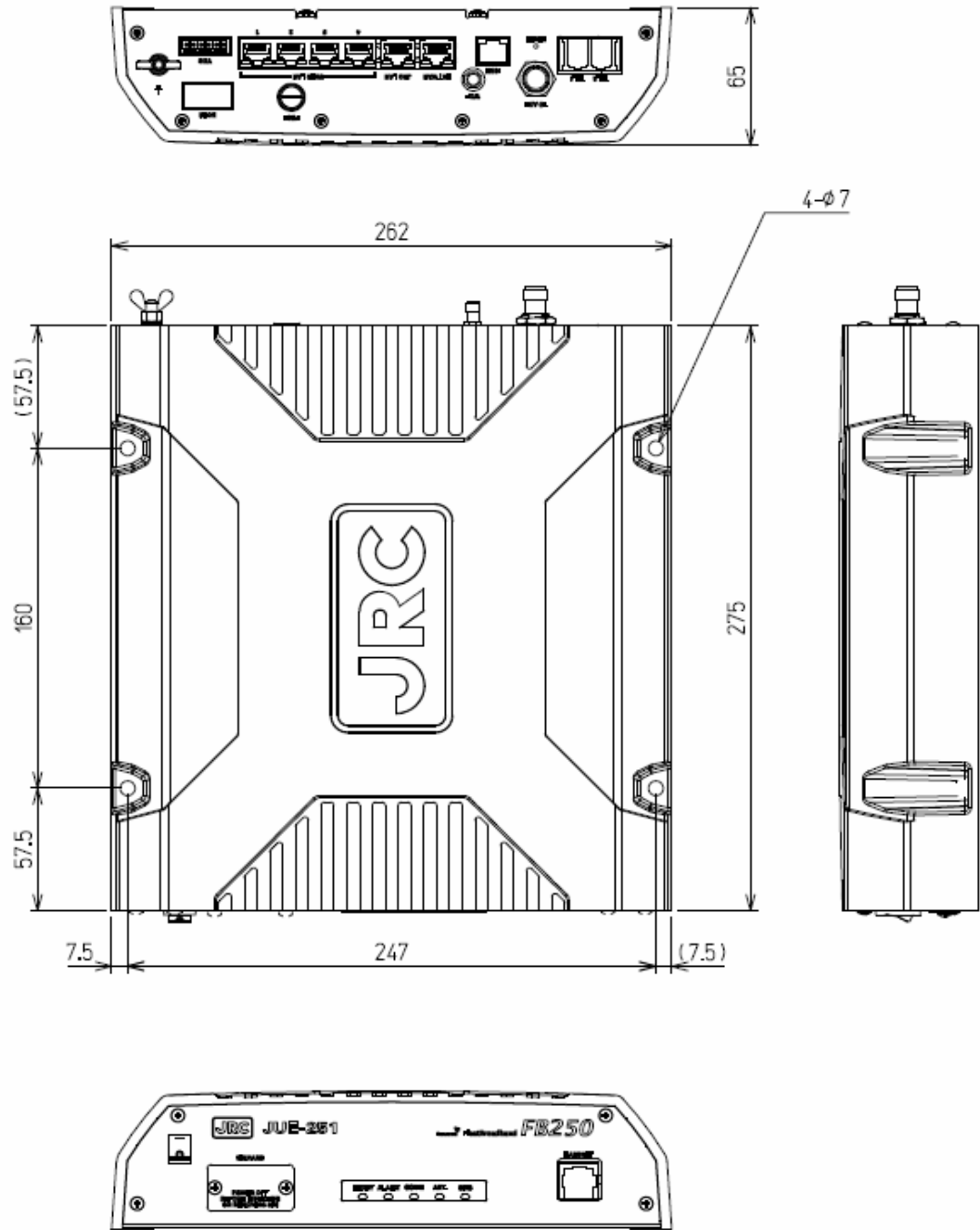

Unit: mm
Mass: approx. 4.5kg

Fig. 2.4.4 Appearance of JUE-251 BDE (GSC-252)

2.4.5 Handset [NQW-267]

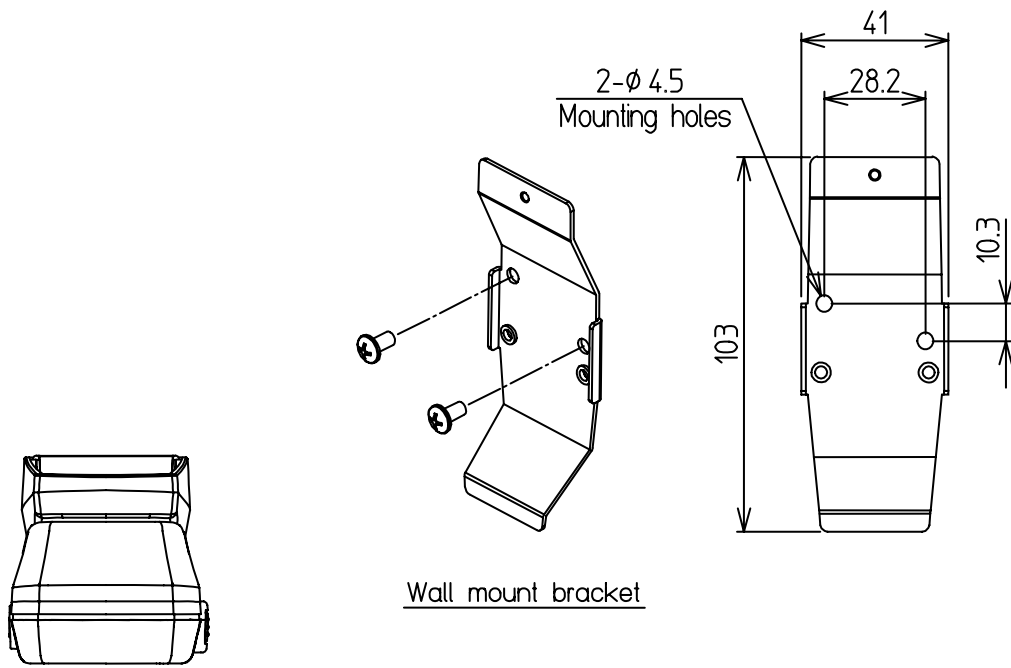

Wall mount bracket

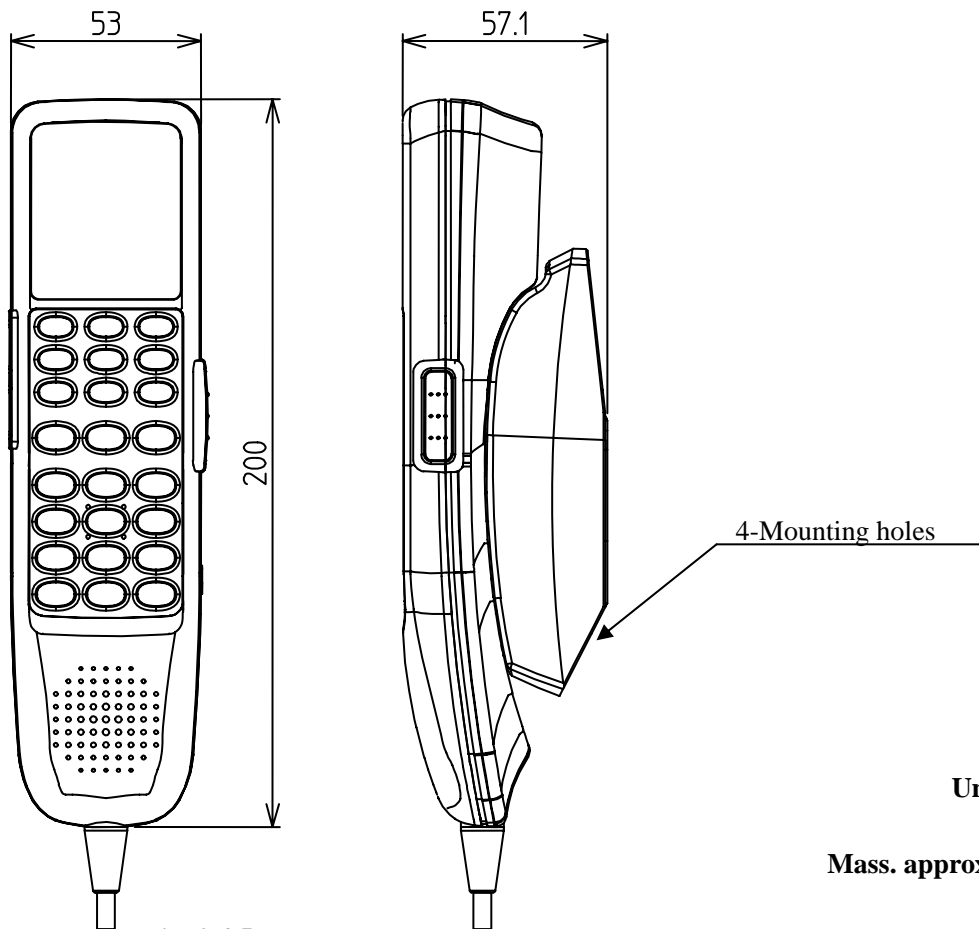

Fig. 2.4.5 Handset

Unit: mm

Mass. approx. 0.5kg

2.4.6 Junction Board [CQD-2243]

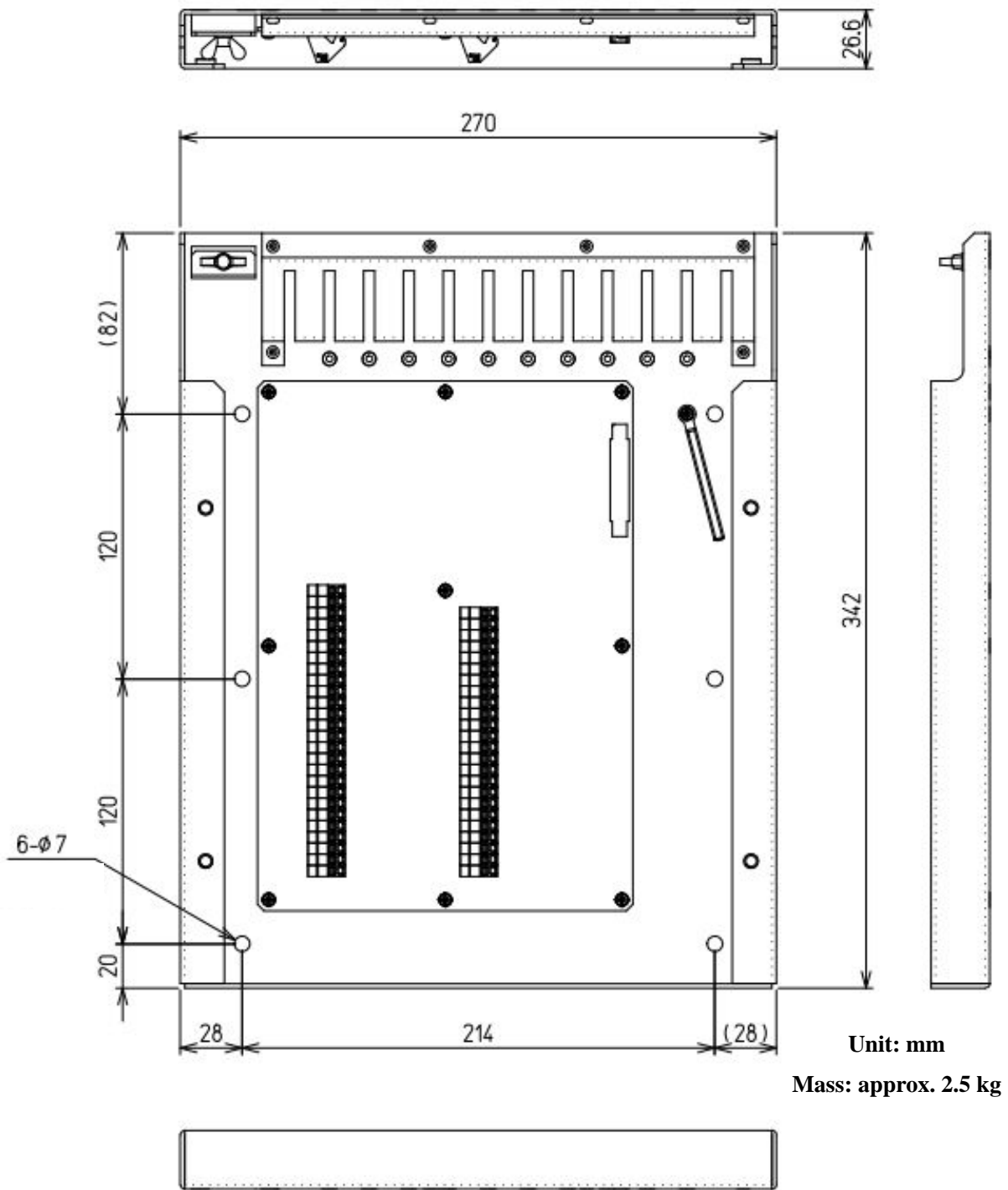
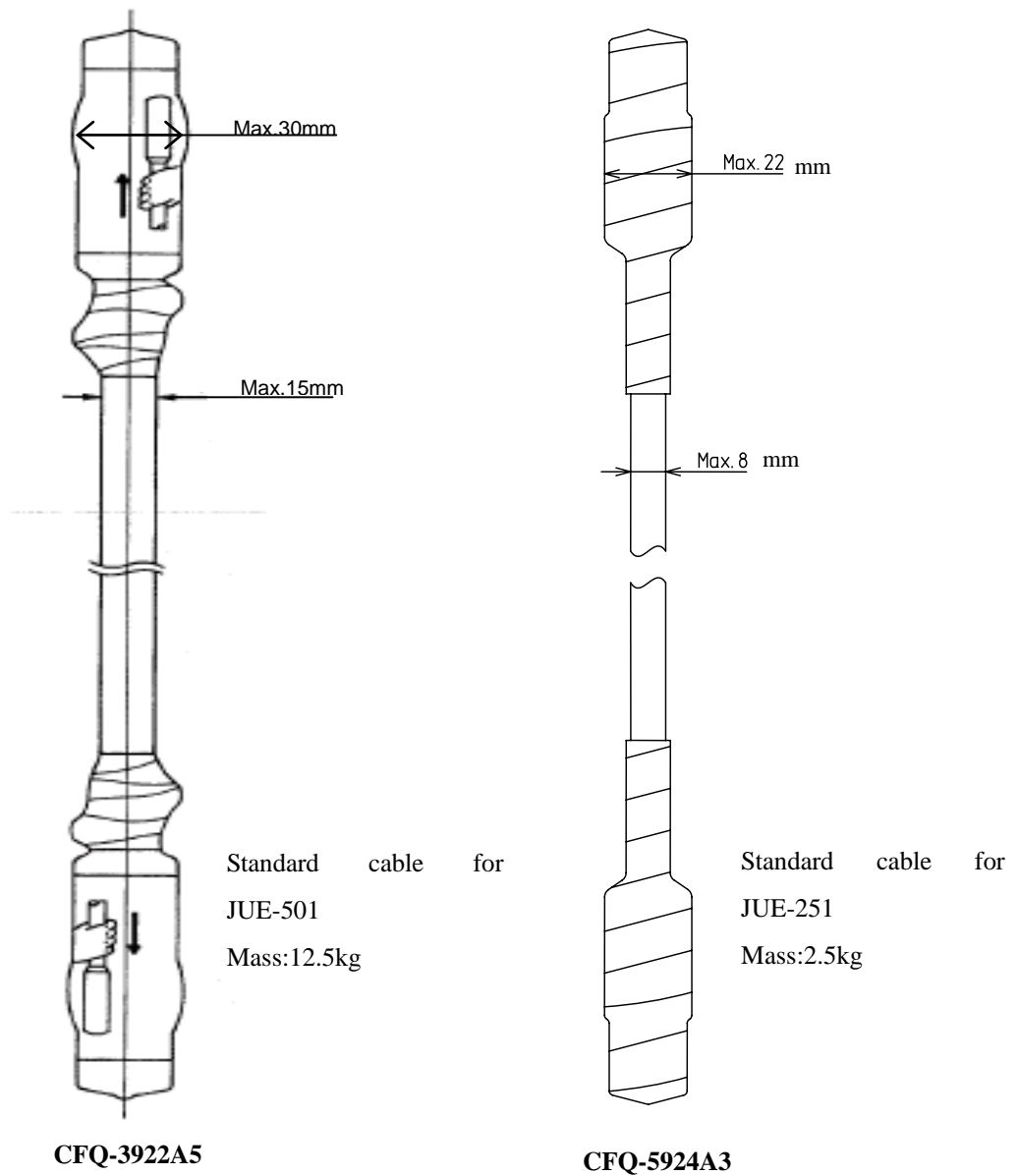

Fig. 2.4.6 Appearance of Junction Board (CQD-2243)

2.4.7 Coaxial cable [CFQ-3922A5/CFQ-5924A3]



Type	Length	Connector Dia.	Cable Dia.	Mass	Minimum bending radius	Remarks
CFQ-3922A5	50m±0.5m	30mm	15mm	12.5kg or less	100mm	Standard for JUE-501 With N connector
CFQ-5924A3	30m±1.0m	22mm	8mm	2.5kg or less	50mm	Standard for JUE-251 With TNC connector

Concerning cable length option, please refer to [Table 2.3.2 Components list].

Fig. 2.4.7 Coaxial cable

2. Introduction of JUE-501/JUE-251

This page is remained as a blank.

3. Appearance

In this section, the composition of the JUE-501/JUE-251 and terminal equipments are explained.

- 1) Above Deck Equipment (ADE): Antenna unit and radome (Antenna Cover)
- 2) Blow Deck Equipment (BDE): Main unit
- 3) Coaxial cable: A Cable connects ADE to BDE
- 4) Handset: Handset and cradle
- 5) Terminal equipments: Accessories used for communication (user supplied PC, FAX, and telephone)

3.1 ADE

Radome covers the antenna equipments, which is composed of:

- a) Low Noise Amplifier (LNA)
- b) Above Deck Unit (ADU) contains GPS circuit.
- c) Rotary joint
- d) Antenna pedestal

All signals (and power) pass through a single coaxial cable, which connects the ADE and BDE.

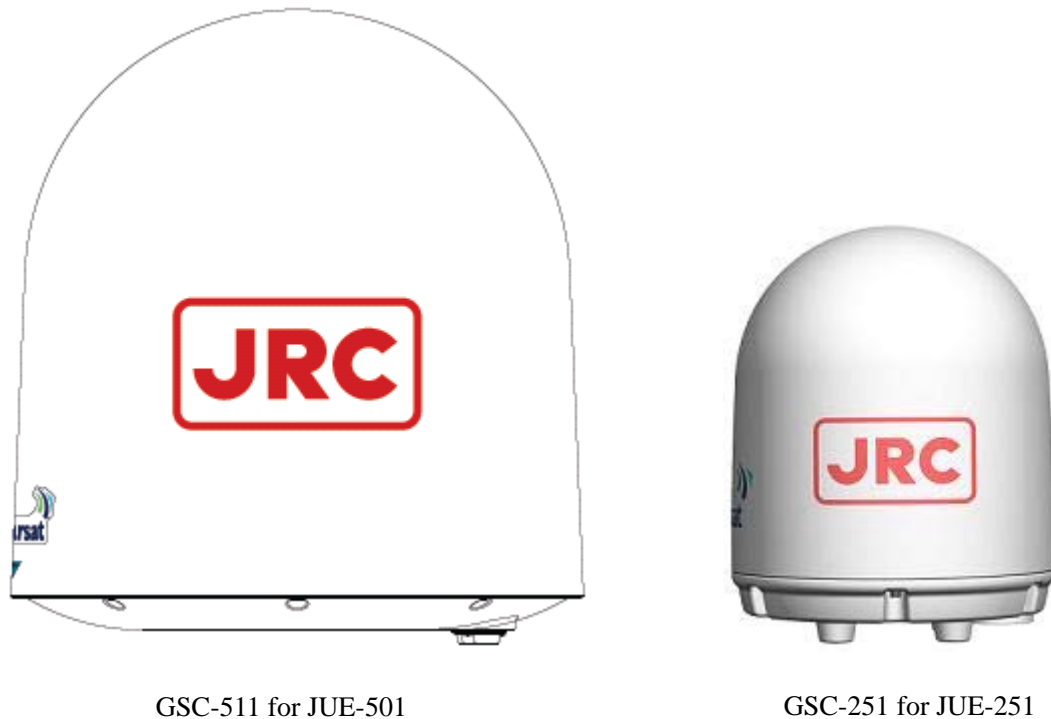

Fig. 3.1 ADE

3. Appearance

3.2 BDE

Main unit

Main unit appearance



Front view



Rear view

Fig. 3.2a Main unit appearance

Front view

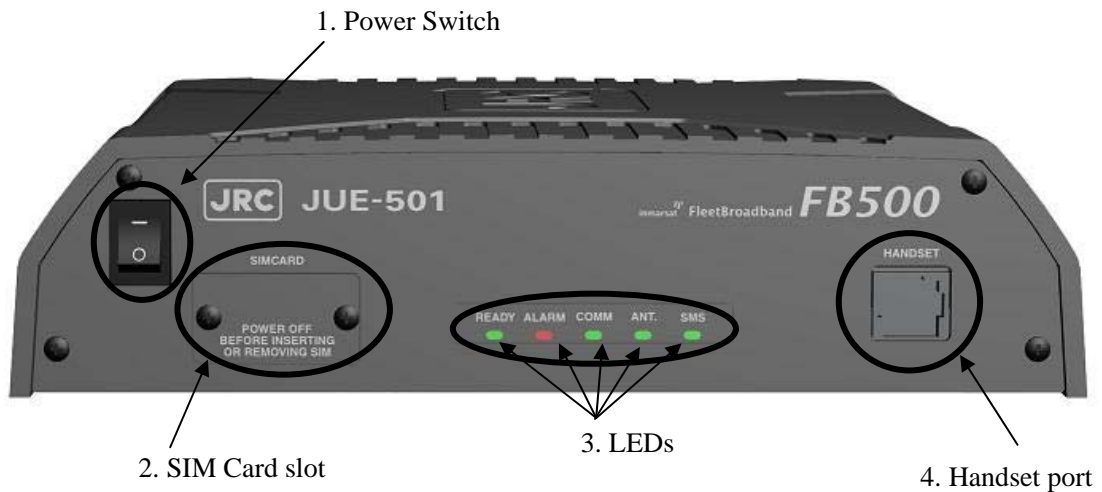

Fig 3.2b Main unit front view

Rear view

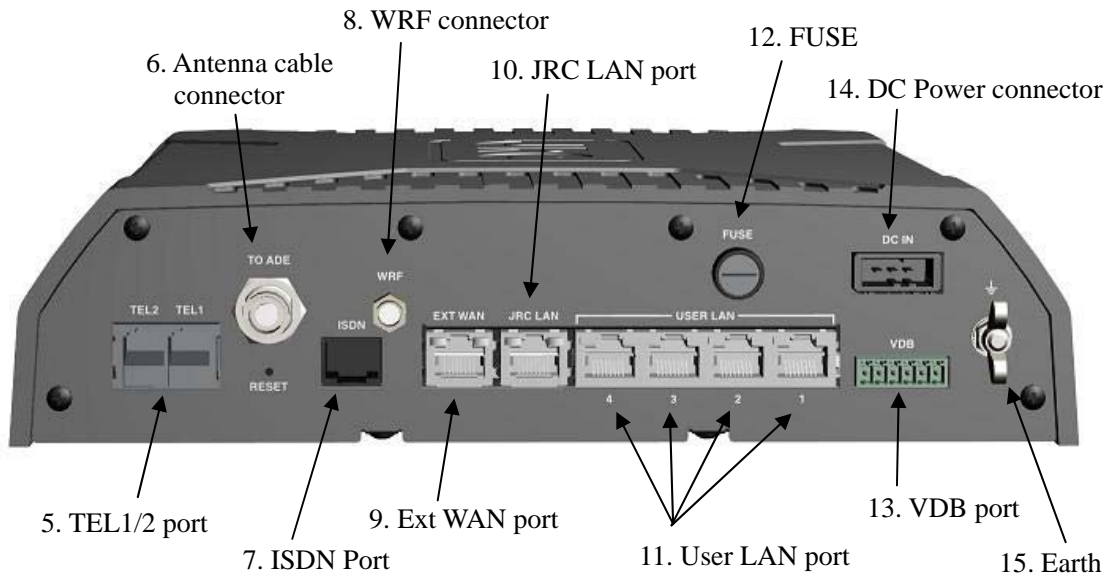

Fig. 3.2c Main unit rear view

- 1 Power Switch
Turns power on and off.
- 2 SIM card slot
Mounts a SIM card.
- 3 LEDs
Indicates the communication/apparatus status. READY LED, ALARM LED and COMM LED lit in the same way as LEDs on the Handset, except at the time of startup. Main unit has two more LEDs (ANT. LED and SMS LED) on its front panel and indicates antenna status and new-SMS-receiving status. The meanings and sequence of the LEDs are described in [Appendix N Front Panel LED lamps].
- 4 Handset port (12-PIN Modular Cable)
Connects with Handset unit.
Offered service: 4kbps Voice and SMS
- 5 TEL 1/2 ports (RJ-11 type 6-PIN Modular Cable)
Connects the analog equipment, terminal telephones, and facsimile to the main unit.
Offered services: 4kbps Voice and 64kbps 3.1kHz Audio
- 6 Antenna cable connector
Connects with the coaxial cable from the antenna (ADE).
- 7 ISDN port (RJ-45 type 8-PIN Modular Cable for ISDN)
Connects with equipment, which has an ISDN interface.
Offered services: 4kbps Voice, 64kbps 3.1kHz Audio, UDI, and RDI

3. Appearance

8 WRF connector

Connects with Wide-band Radio Frequency (WRF) communication equipment such as Chartco etc.

9 Ext WAN port (RJ-45 type 8-PIN Modular Cable for Ethernet)

Connects with External WAN such as ESV.

10 JRC LAN port (RJ-45 type 8-PIN Modular Cable for Ethernet)

Connects with JRC LAN. It creates additional value like remote maintenance or status monitor by connecting JRC products other than FBB.

11 User LAN port × 4 (RJ-45 type 8-PIN Modular Cable for Ethernet)

Connects with user device such as user PC.

Offered services: Standard IP, Streaming IP, and SMS.

A maximum total capacity of 32 W PoE (Power over Ethernet) is available on User LAN.

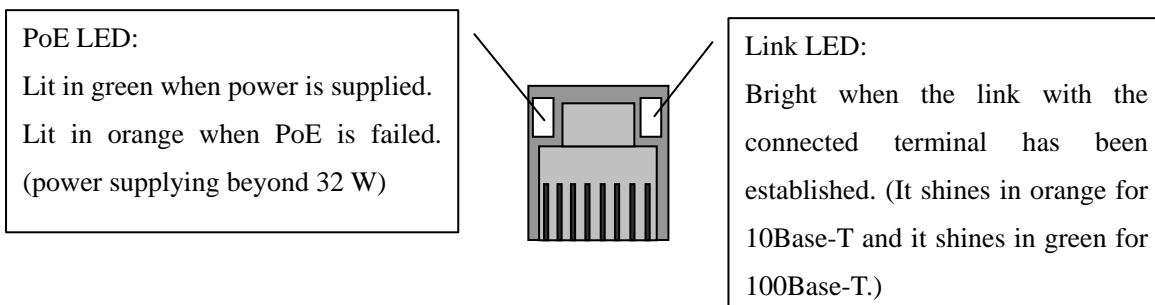

12 Fuse

Melt down when over current are detected.

Replacement procedure: Loosen the folder head to counterclockwise direction with slotted screwdriver, and pull out the folder when it is ejected. Replace the fuse to new one and set it in the folder. Insert the folder and tighten it clockwise direction until folder is securely locked in place.

13 VDB port

Connects with Voice Distress Button (VDB).

14 DC power connector

Connects with the cable which supplies the power source to the main unit.

15 Earth

3.3 ADE - BDE connecting cable

*** This cable can be connected to ADE and BDE in either direction.**

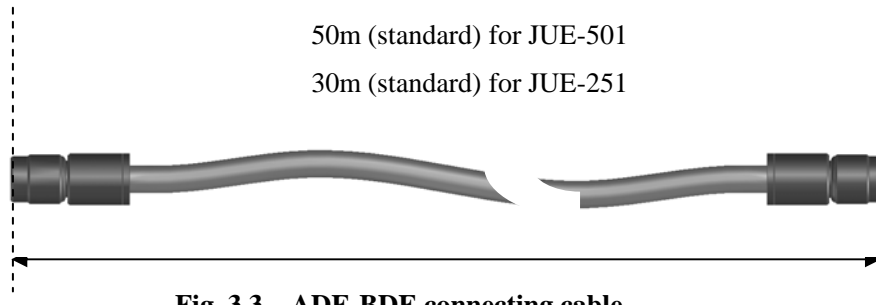



Fig. 3.3 ADE-BDE connecting cable

3. Appearance

3.4 Handset

The Handset consists of main body and cradle (Handset rest)

The Handset is fixed on the cradle by a strong magnet.



CAUTION



Do not mount the Handset near CRT device or other devices; otherwise performance of the devices may be affected by the Handset's magnetic field.

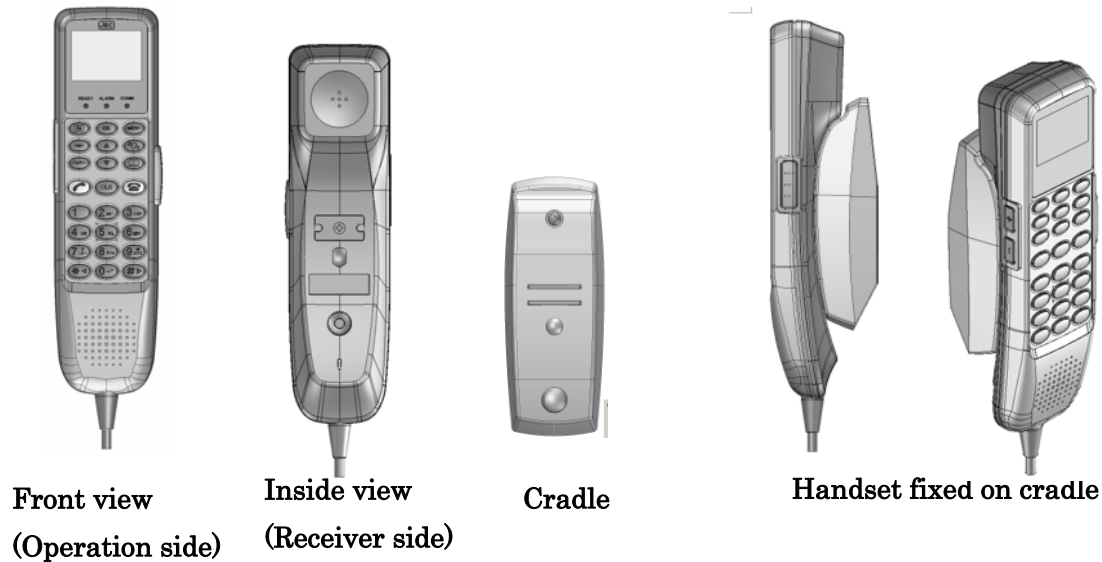

Fig 3.4a Handset and cradle

Handset operation side consists of three sections:

3.4.1. LCD / LED section

LCD screen displays JUE-501/JUE-251 user information.

LEDs indicate communication/apparatus status.

3.4.2. Functional button section

Buttons in this section control basic functions of the JUE-501/JUE-251.

3.4.3. Alpha-Numeric button section

Numeric mode is used to enter number sequences like phone numbers. Alpha mode is used to enter letters.

These two modes are switched by pressing **Aa** button of the Function section.

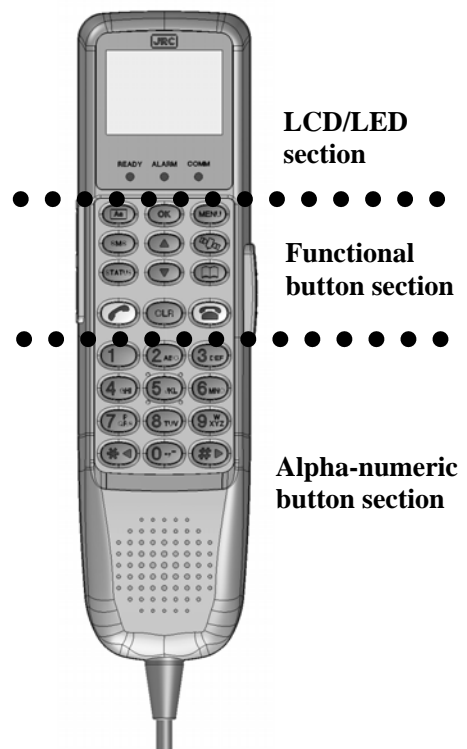













Fig. 3.4b Section of Handset

3.4.1 LCD/LED section

Functions of the LCD screens of the Handset.

Common items for all screens are:

- 1 [Operational button] Displays operatable keys: ,  or 
- 2 [Enter mode] Displays which key enter mode is accepted, **Aa** (alphabet mode), or nothing (numeric mode) is displayed. (Only in SMS editing mode, **aA** is displayed)
- 3 [Each status] Displays every status : , , , ,  or 
- 4 [Condition of reception] Displays  style icon
- 5 [Connecting IP service] Displays  style icon
- 6 [Selected satellite] Displays E143.5 etc.
- 7 [Current time] Displays UTC/LT, or communicating time.
- 8 [Status of equipment] Displays CS PS READY, COMM (OUT), etc.

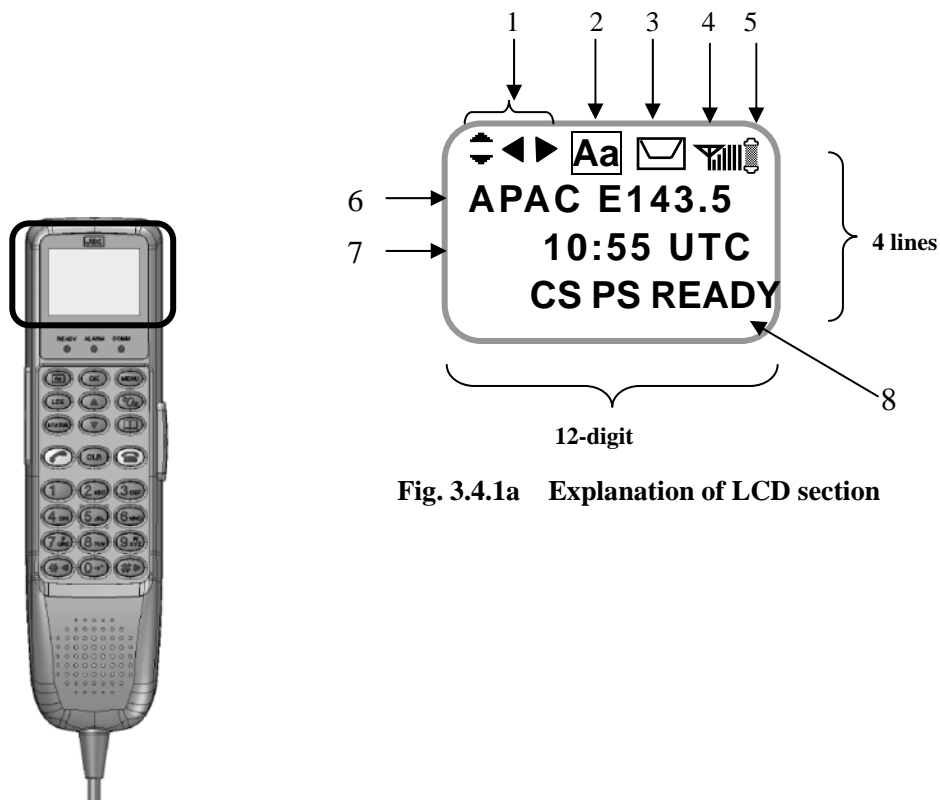
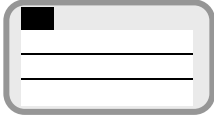







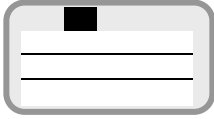



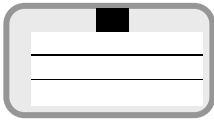















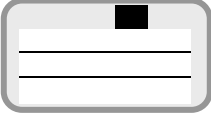





















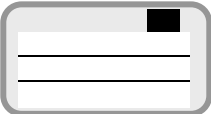
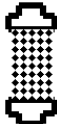

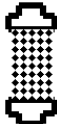

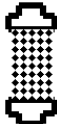

Fig. 3.4.1a Explanation of LCD section

Fig. 3.4.1b LCD section

3. Appearance

Table 3.4.1 Explanation of items displayed on screens

Displayed items	Contents
<p>1 Operational button</p> 	<p>Displays when the scrolling-up/down or switching-left/right is available.</p> <p>Scroll the screen when up/down  is displayed, with   buttons.</p> <p>Switch the screen when left/right   is displayed, with   buttons.</p>
<p>2 Input mode</p> 	<p>Displays  mark for alphabet input mode. If these icons are not displayed, numeric input mode only available.</p> <p>(Except in SMS menu,  is displayed as lower case letter mode and  is displayed as upper case letter mode.)</p>
<p>3 Each status</p> 	<ol style="list-style-type: none"> 1) Displays  when Phonebook menu is selecting. 2) Displays  when Redial menu is selecting. 3) Displays  when call is on hold. 4) Displays  when SMS message is arrived. 5) Displays  when the storage volume of SMS message is FULL. 6) Displays  when FAX is out of service. <p>This  icon is :</p> <ul style="list-style-type: none"> • Displaying the storage volume on SIM card for SMS message is full. To send and receive new message, please delete unnecessary messages. <p>This  icon is :</p> <ul style="list-style-type: none"> • Not displayed even new message is received, when another icons (, , ,  and ) are need to be displayed in this area. • Disappeared when Inbox menu (refer to [8.2.2 Inbox menu](p8-15)) is selected and [Inbox list view screen] is once opened, regardless of the newly arrived message is read or not. • Disappeared when Power OFF with displaying it, and ON afterwards. • Kept displaying even the new message is read, when it is executed by an external access such as PC. <p>This  icon is :</p> <ul style="list-style-type: none"> • Displaying FAX is out of service. This icon is displayed when satellite elevation angle (EL) value of JUE-251 is less than 20 degrees.

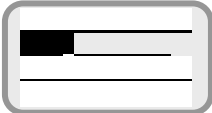
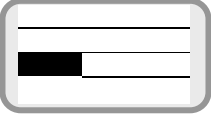
<p>4 Condition of reception</p> 	<p>1)Displays a bar graph of signal reception level by seven (7) grades. It blinks when antenna was hidden from satellite by obstructions.</p> <table border="1" data-bbox="459 304 1393 705"> <thead> <tr> <th data-bbox="459 304 751 353">Number of bars</th> <th data-bbox="751 304 1393 353">Communication</th> </tr> </thead> <tbody> <tr> <td data-bbox="459 353 751 405">0 </td> <td data-bbox="751 353 1393 405">Impossible (no reception)</td> </tr> <tr> <td data-bbox="459 405 751 456">1 </td> <td data-bbox="751 405 1393 456">Possible to communicate but unstable</td> </tr> <tr> <td data-bbox="459 456 751 508">2 </td> <td data-bbox="751 456 1393 508">Possible to communicate but unstable</td> </tr> <tr> <td data-bbox="459 508 751 560">3 </td> <td data-bbox="751 508 1393 560">Possible to communicate stably</td> </tr> <tr> <td data-bbox="459 560 751 611">4 </td> <td data-bbox="751 560 1393 611">Possible to communicate stably</td> </tr> <tr> <td data-bbox="459 611 751 663">5 </td> <td data-bbox="751 611 1393 663">Possible to communicate stably</td> </tr> <tr> <td data-bbox="459 663 751 705">6 </td> <td data-bbox="751 663 1393 705">Possible to communicate stably</td> </tr> </tbody> </table>	Number of bars	Communication	0 	Impossible (no reception)	1 	Possible to communicate but unstable	2 	Possible to communicate but unstable	3 	Possible to communicate stably	4 	Possible to communicate stably	5 	Possible to communicate stably	6 	Possible to communicate stably
Number of bars	Communication																
0 	Impossible (no reception)																
1 	Possible to communicate but unstable																
2 	Possible to communicate but unstable																
3 	Possible to communicate stably																
4 	Possible to communicate stably																
5 	Possible to communicate stably																
6 	Possible to communicate stably																
<p>5 Connecting IP service</p> 	<p>1)Displays an icon which shows connecting IP service .</p> <table border="1" data-bbox="459 779 1393 1288"> <thead> <tr> <th data-bbox="459 779 751 828">Icon style</th> <th data-bbox="751 779 1393 828">IP service type</th> </tr> </thead> <tbody> <tr> <td data-bbox="459 828 751 974"></td> <td data-bbox="751 828 1393 974">Standard IP service only.</td> </tr> <tr> <td data-bbox="459 974 751 1120"></td> <td data-bbox="751 974 1393 1120">Streaming IP service only.</td> </tr> <tr> <td data-bbox="459 1120 751 1288"></td> <td data-bbox="751 1120 1393 1288">Both of above IP services.</td> </tr> </tbody> </table>	Icon style	IP service type		Standard IP service only.		Streaming IP service only.		Both of above IP services.								
Icon style	IP service type																
	Standard IP service only.																
	Streaming IP service only.																
	Both of above IP services.																
<p>6 Selected Satellite</p> 	<p>Displays selected satellite /communicating terminals.</p> <ul style="list-style-type: none"> • Satellite (Displays when CS communication is not used) It displayed in units of 0.1 degree, and in the range of W180.0 to E180.0 																
<p>7 Current time</p> 	<p>Display is changed between UTC (Universal Time coordinated) and LT (Local Time).</p> <p>If you set the time difference, the display is switched to LT automatically.</p> <p>Refer to [7.9.1.2 Local Time setting](p7-38).</p>																

3. Appearance

8 Status of equipment

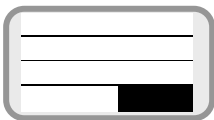

Displayed only in SMS menu

The items in this table are arranged in displaying priority.

Displays the status of equipment. Normally, this area displays below contents under waiting communication or under transmitting.

Status of equipment	Displayed txt.	Contents
Normal	nnn/NNN	Displays the used amount (nnn) and total capacity (NNN) of input characters of SMS
Abnormal	ADE?	ADE is abnormal condition
Abnormal	SIM?	SIM is abnormal condition
Abnormal	POSITION?	GPS does not receive the radio wave from satellite. It is not always failure. The other factors including blocking can be considered.
Normal	HEADING?	GYRO of Sync/Step requires Heading value
Abnormal	GYRO?	GYRO is abnormal condition.
Normal	COMM (OUT)	Called from the ship.
Normal	COMM (IN)	Called from the land.
Normal	SAT SEARCH	Searching Satellite.
Normal	REGISTERING	It is displayed from the Satellite search is completed and until READY status is started.
Abnormal	SEARCH NG	Satellite search has been failed.
Normal	CS PS READY	Communication is possible. (Circuit switch service and Packet switch service are available)
Normal	CS READY	Communication is possible. (Circuit switch service only available)
Normal	PS READY	Communication is possible. (Packet switch service only available)
Normal	NOT READY	Communication is impossible.

Lighting of LEDs

Ready lamp: displays communication status
(available/non-available)

Green light: All communication services are available.

Blinking Green: No service is available
(starting system, calibrating cable, searching satellite or registering SIM).

Orange light: Registration failure or SIM card is not inserted.

Blinking Orange:

- Starting system with initialization.
- After power switch is turned off, until the power is run out completely.

Red light: System is in Safe Mode.

Blinking Red: Failure has been detected in starting system.

(No light: power switch is OFF)

ALARM lamp: indicates failure alert

Red light: Failure has occurred in the system.

(No light: The status is normal)

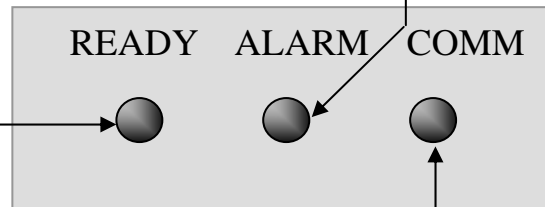

COMM lamp: indicates communication starting.

Green light: In CS service communication

(No light: In PS service communication, or no CS service communication is on the way now.)

Fig. 3.4.1c Indication of LEDs



LEDs on the Handset are lit in the same way as the main unit, except just after the startup.

3. Appearance

3.4.2 Functional button section

This section describes function buttons except those for entering characters.

Buttons and its function























-  **Switching button** Switches enter mode, between alphabets and numbers.
-  **SMS button** Reads, creates, sends, and deletes Short Message Service (SMS).
-  **Status button** Makes direct access to STATUS menu.
-  **OK button** Registers entered contents.
-  **Scroll up button**
Scrolls up the screen / makes direct access to Redial menu.
-  **Scroll down button**
Scrolls down the screen/makes direct access to Redial menu.
-  **Menu button** Makes direct access to TOP Menu.
-  **Satellite button** Makes direct access to Satellite menu.
-  **Phonebook button** Makes direct access to Phonebook menu.
-  **Off Hook(Call starting)button** Makes a call and receives a call.
-  **Clear button** Clears (cancels) the entry immediately before.
-  **On Hook(Call finishing)button** Hangs up the call.



Fig. 3.4.2 Functional button section

3.4.3 Alpha-numeric button section

Buttons and usage

- 
- 
- 
- 
- 
- 
- 
- 
- 
- 

This button adjusts the voice volume and the screen brightness of the Handset.

Enters numerical/alphabetical characters and symbols.

Enters # and also scrolls the screen to the right direction.

Enters* and also scrolls the screen to the left direction.

FN button.
This button is used for call waiting and call holding.

This button has no function.

Fig. 3.4.3 Alpha-numeric button section

3.5 Communication terminals

3.5.1 Terminal requirements

*Series connection (of terminal telephone and FAX) is not available on one port.

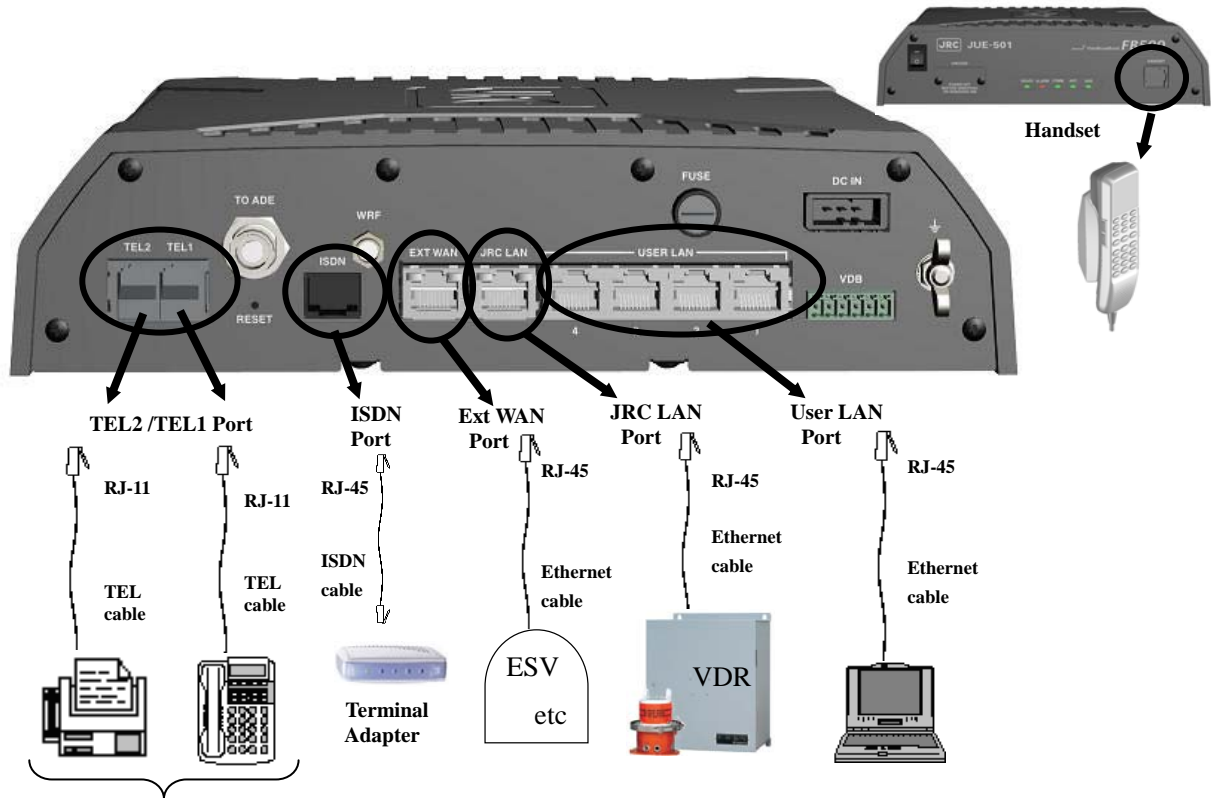

NOTE

Service type of TEL1/2 port must be set properly according to the connected terminal (telephone or FAX).
(Refer to p4-12 for Service type modification).

NOTE

JUE-501/JUE-251 recognizes the type of Ethernet cable (cross or straight) automatically.
A maximum of total 32W PoE (Power over Ethernet) is available on User LAN.

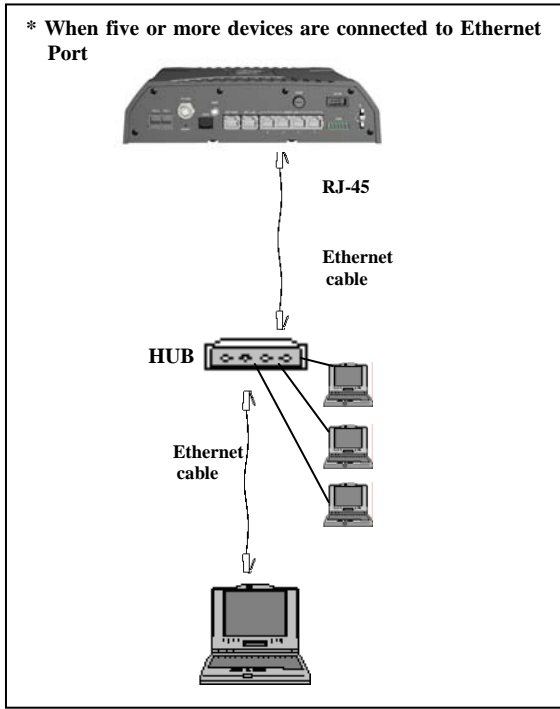

Fig. 3.5.1 Terminal requirements

3. Appearance

3.5.2 Usage environment

Table 3.5.2 Usage environment

PC	OS	Microsoft Windows XP/ Vista/ 7
	Interface	Ethernet
ISDN Terminal Equipment	Switch type	Euro ISDN, INS
	Coding type of voice	A-law, μ -law
	Interface	RJ-45 (S/T interface)

3.6 Handset menu

On the JUE-501/JUE-251, various menu screens can be displayed and set, from Handset.

Guest User ^{*1)} cannot utilize the menus of Admin User ^{*2)}.

*1) Guest User: General user

*2) Admin User : User who is authorized to make settings of the JUE-501/JUE-251.

Handset menu

For more detail, refer to [7. Handset Menu System](p7-1).

Displays JUE-501/JUE-251 status and of communication status(For all user)

Status

(Displays internal status for carry out communication)

SMS

(Reads/creates/sends/ deletes SMS)

Satellite

(Selects satellite, and displays spot beam No.)

Phonebook

(Registers Speed Dial Number to the Handset and terminal telephone)

Redial

(Displays Redial number list and makes a call with it)

Internal

(Make an internal call)

Call Log

(Displays Call logging history)

Alarmpack

(Displays detailed Information of JUE-501/251 and Alarm history)

Changes JUE-501/JUE-251 status and communication status (For Admin user only)

Admin

(Displays menu list for the ADMIN user)

Terminal

(Setups the basic operation of BDE)

Telephony

(Setup the telephony including auto answer and supplementary service)

Port

(Setup each port)

User Cont.

(Registers users and restricts them)

Auto Dcn.

(Sets automatic disconnection of communication)

SIM menu

(Sets SIM card-use operation)

Default

(Resets to the factory default)

Fig. 3.6 Handset menus (Classified by user authority)

4. Getting started

In Section 4.1, connecting the Handset and terminal devices to Main unit, and installing SIM card are described; and initial setting for communication is described in Section 4.2.

NOTE

JUE-501/JUE-251 has two types of satellite tracking mode, **Signal tracking mode** and **Gyro tracking mode**.

Press **MENU+3** button (Satellite menu) on the Handset. [3.Heading] is displayed when the JUE-501/JUE-251 is set as Gyro tracking mode.

You can use **Web browser** or **LaunchPad** for the Packet switching service (Standard/Streaming IP communication).

About Web browser

JUE-501/JUE-251 is accessible by Web browser on your PC. Functional adjustment of JUE-501/JUE-251 as well as fundamental services like displaying the status/setting of JUE-501/JUE-251, connecting/disconnecting Standard/Streaming IP service, and sending/receiving SMS can be made by Web browser.

NOTE

- Refer to [Chapter 6 Web Menu System](p6-1) of this manual to control BDE by Web browser.
- JUE-501/JUE-251 supports Microsoft Internet Explorer 7, Mozilla Firefox 3.6 and their later version.

About the LaunchPad

LaunchPad is the application software manufactured by Inmarsat for handling Mobile Earth Station (MES). Fundamental services are also available by using LaunchPad.

NOTE

- Refer to [Appendix I] and [Appendix J] of this manual to install and to use the LaunchPad.
- LaunchPad version 5.0.4 or later supports the Windows XP/Vista/7 32bit.

About the TCP accelerator (TCP PEP)

TCP accelerator (TCP PEP) is PC application software which improves the performance of TCP applications (transfer rate) over FleetBroadband network.

Install TCP accelerator (TCP PEP) to your PC using attached CD-ROM if necessary.

NOTE

- If using TCP accelerator is not made by Inmarsat, or depending on the type of application, transfer rate may not be improved.
- The TCP accelerator version2 or later supports the Windows XP/Vista/7 32bit and Windows 7 64bit.

4. Getting started

4.1 Connecting terminals and power on

4.1.1 Connecting terminals with cables

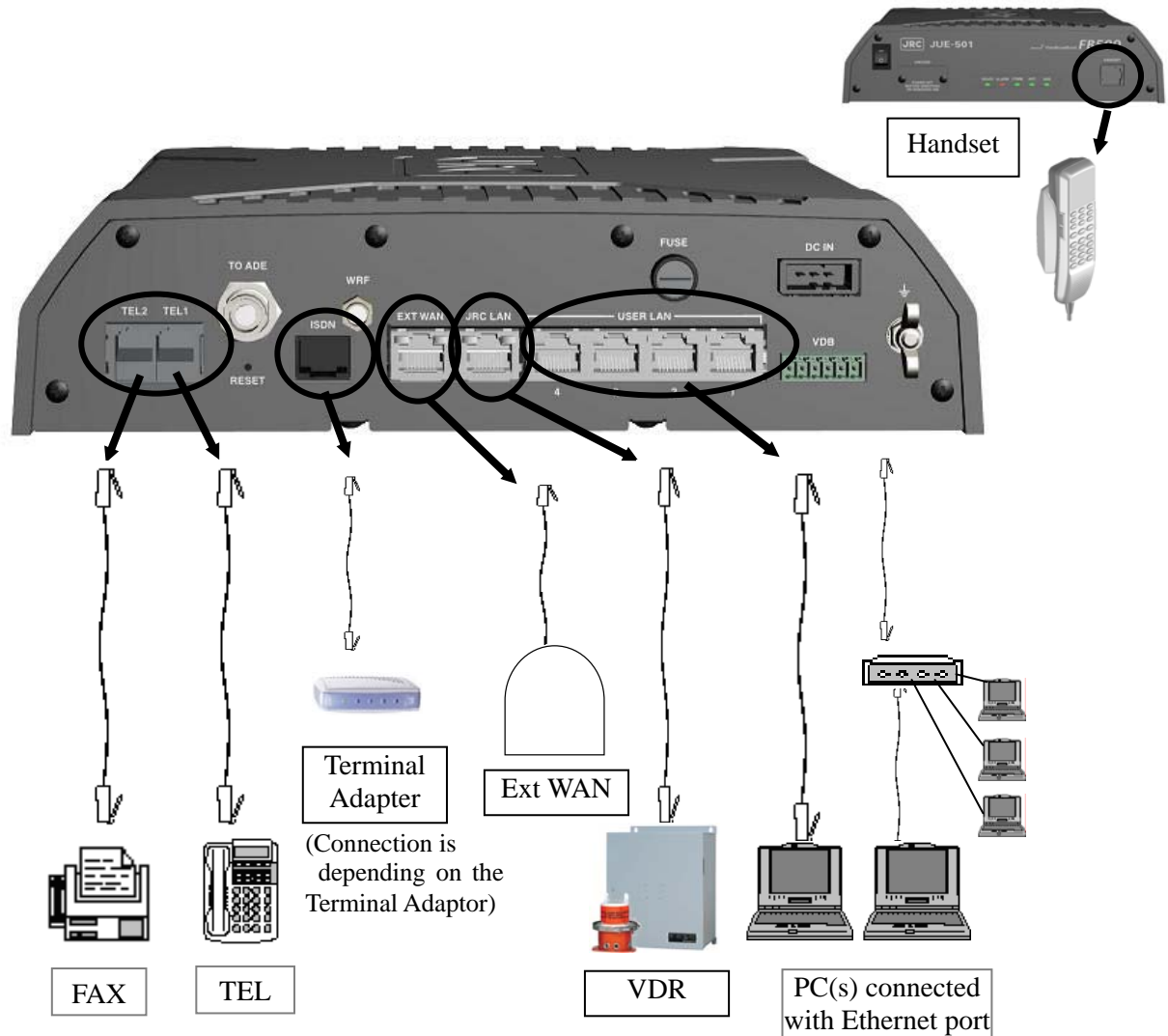

Fig.4.1.1 The Cable connection of each terminal

NOTE

- The JUE-501/251 recognizes Ethernet cable type (cross or straight) automatically.
- Service type of TEL1/2 port must be set properly according to the connected terminal (telephone or FAX). (Refer to p4-12 for Service type modification).
- A maximum of total 32W PoE (Power over Ethernet) is available on User LAN.

Connecting terminal telephone and FAX to TEL1/2port

Connect terminal telephone/FAX to TEL1 and TEL2 port with 2 wire, 6-PIN modular cable (RJ-11 type).

Connecting Handset to Handset port

Connect adapter of Handset to Handset port.(12-PIN modular cable)

Connecting PC to User LAN port

Connect your PC to User LAN port with Ethernet cable.

Connecting VDR to JRC LAN port

Connect VDR (produced by JRC) to JRC LAN port with Ethernet cable if needed.

Connecting external WAN to Ext WAN port

Connect external WAN to Ext WAN port with Ethernet cable if needed.

Connecting terminal adapter to ISDN port

Connect terminal adapter to ISDN port with ISDN cable.

(Subsequent connection depends on the type of terminal adapter)

4. Getting started

4.1.2 Setting/removing SIM card

Please make sure that SIM card is inserted correctly before turning on the power every time.

NOTE

- JUE-501/JUE-251 will not work without a **valid SIM** card, which is furnished from the Distribution Partner.
- Make sure that power switch is correctly turned off, before you set/remove the SIM card to/from main unit.

CAUTION



Do not set/remove the SIM card during power switch is turned on.

SIM card setting procedure (Before power switch is turned on)

- 1) Remove the SIM card protector by unscrewing cross-head screws on front panel.
- 2) Insert your SIM card with the metal side down. Push it in until you hear the SIM card slot make a click sound.
- 3) Fasten the SIM card by sliding the black knob.
- 4) Restore the SIM card protector by driving the screws in.



SIM card removing procedure (After power is turned off)

- 1) Remove the SIM card protector by unscrewing cross-head screws on front panel.
- 2) Loosen the SIM card by sliding the black knob.
- 3) Push the SIM card and then it comes out. Remove the SIM card.
- 4) Restore the SIM card protector by driving the screws in.

4. Getting started

4.1.3 Power ON

Before turning on the power, check the following;

- Check the obstacles between antenna and satellite.
- Check that SIM card is correctly set.
- Check that the breaker of inboard power supply is turned on.
- Check that the coaxial cable from ADE is connected to BDE, certainly.
- Check that the Handset is connected to BDE, certainly.

Power ON

Turn the “POWER” switch of the main unit to “ON”.

The READY LED on the front panel will light up in green and start blinking. After a while, the ANTENNA lamp will start blinking and then both lamps will stop blinking and light green.

Although there is nothing wrong with JUE-501/JUE-251, turning on the switch makes some noise on ADE.

Power OFF

Turn the “POWER” switch to “OFF”.

Then, the READY lamp begins blinking in orange color, while the power source disconnecting process is carried out. After, the power source disconnecting process is completed, the power supply is turned off.

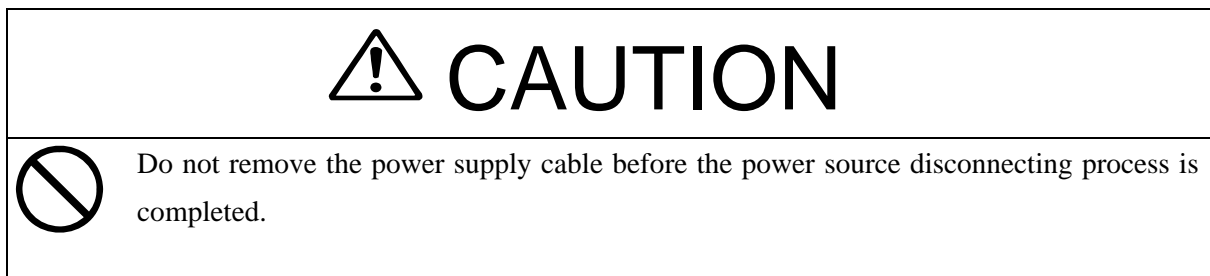

Fig.4.1.3a Power switch and LEDs of Main unit

Satellite Search (acquisition) function works automatically

When JUE-501/JUE-251 is turned on, the system automatically calculates the satellite position by measuring ship's position by GPS (built-in), and then automatically turns the antenna towards the satellite.

After acquiring the satellite, the JUE-501/JUE-251 automatically controls the antenna angle to maximize receiving signal strength.

LCD screen of Handset displays "CS PS READY" when communication is available.

NOTE

If the communication fails although LCD screen shows [CS PS READY], low level of receiving signal strength is suspected. Try the communication again after a while.

Initialization of the unit may take more than 5 minutes to complete. During this time, "CS PS READY" may not be displayed on the screen. It is not abnormal status (the JUE-501/JUE-251 is executing the initialization, satellite search, and registering to the network).

NOTE

Please confirm that the GPS you are using reports proper position. (Refer to [7.1.3 Position status display],p7-6).

Contact the purchasing dealer, JRC agent or one of the JRC branches with confirming above matter, when the satellite search function does not work.

"SEARCH NG" is displayed in status column of Handset screen, when automatic satellite search function is failed. In this case, carry out satellite acquisition again manually after checking that there is no obstacle between the antenna and the satellite (refer to [4.2.3. Setting satellite search]) (p4-14). If satellite search was not executed manually, JUE-501/JUE-251 will restart satellite search automatically after 10 minutes.

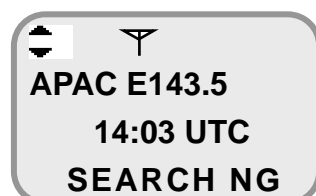
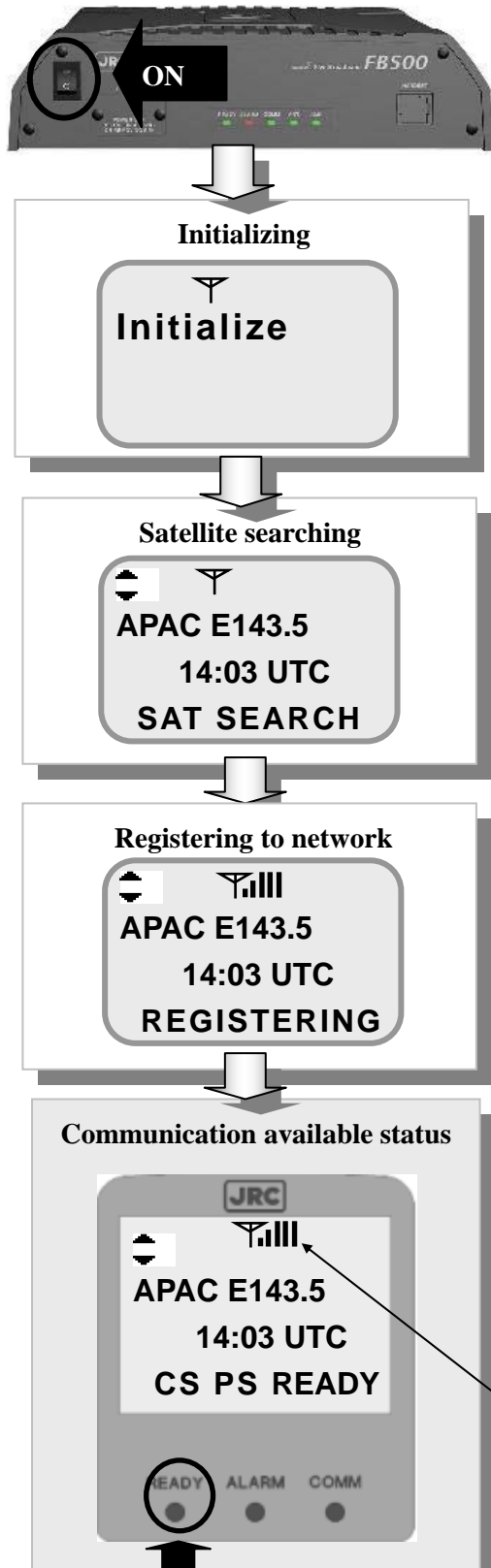

Fig. 4.1.3b SEARCH NG status of Idle screen

4. Getting started

4.1.4 Screen display of Handset



Turn on JUE-501/JUE-251 by pushing power switch off Main unit.

If Gyro is being selected for tracking, refer to Appendix C.3.

A LED of Main unit starts blinking.
 About 90 seconds later, initializing is started and blinking [Initialize] text is displayed.
 It takes about 1 minute until satellite searching is started.

[SAT SEARCH] text is displayed on the lowest, [Status] line. Satellite search is started.

Satellite search is terminated and then [REGISTERING] text is displayed.
 Registering to Inmarsat network is started.

Registering is terminated and [CS PS READY] text is displayed.
 Various services are available.

- * Antenna bars display communication status
- 0 : Impossible to communicate (no reception)
- 1 to 2: Possible to communicate but unstable
- 3 to 6: Possible to stable communicate

[READY] lamp lit.
 (Refer to [3.4.1. LCD/LED section] (p3-11).

Go to chapter 4.2 for initial setting.

Fig.4.1.4a Screen transition when Power switch is turned on

(Screen transition when power switch is turned off)

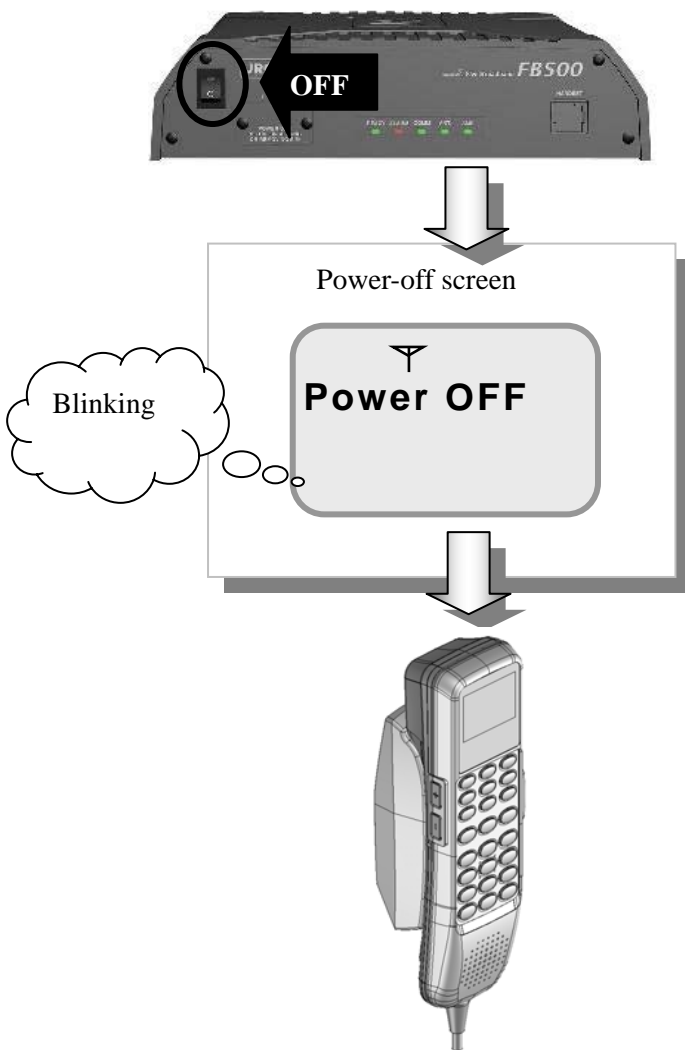

Turn off the power switch.

Quitting operation is on the way in the JUE-501/JUE-251. Characters on the screen blink.

Screen and all LEDs are turned off. Operation is completed.

Fig.4.1.4b Screen transition when Power switch is turned off

NOTE

Carry out available countermeasure referring to [7.10.Other screen: TX alarm screen] (p7-77), when JUE-501/JUE-251 displays the below screen during communication.

These screens indicate a failure has occurred on the communication system of the JUE-501/JUE-251.

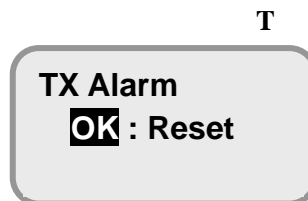

Fig. 4.1.4c TX alarm screen

4. Getting started

4.2 Initial setting for communication

Setting flow

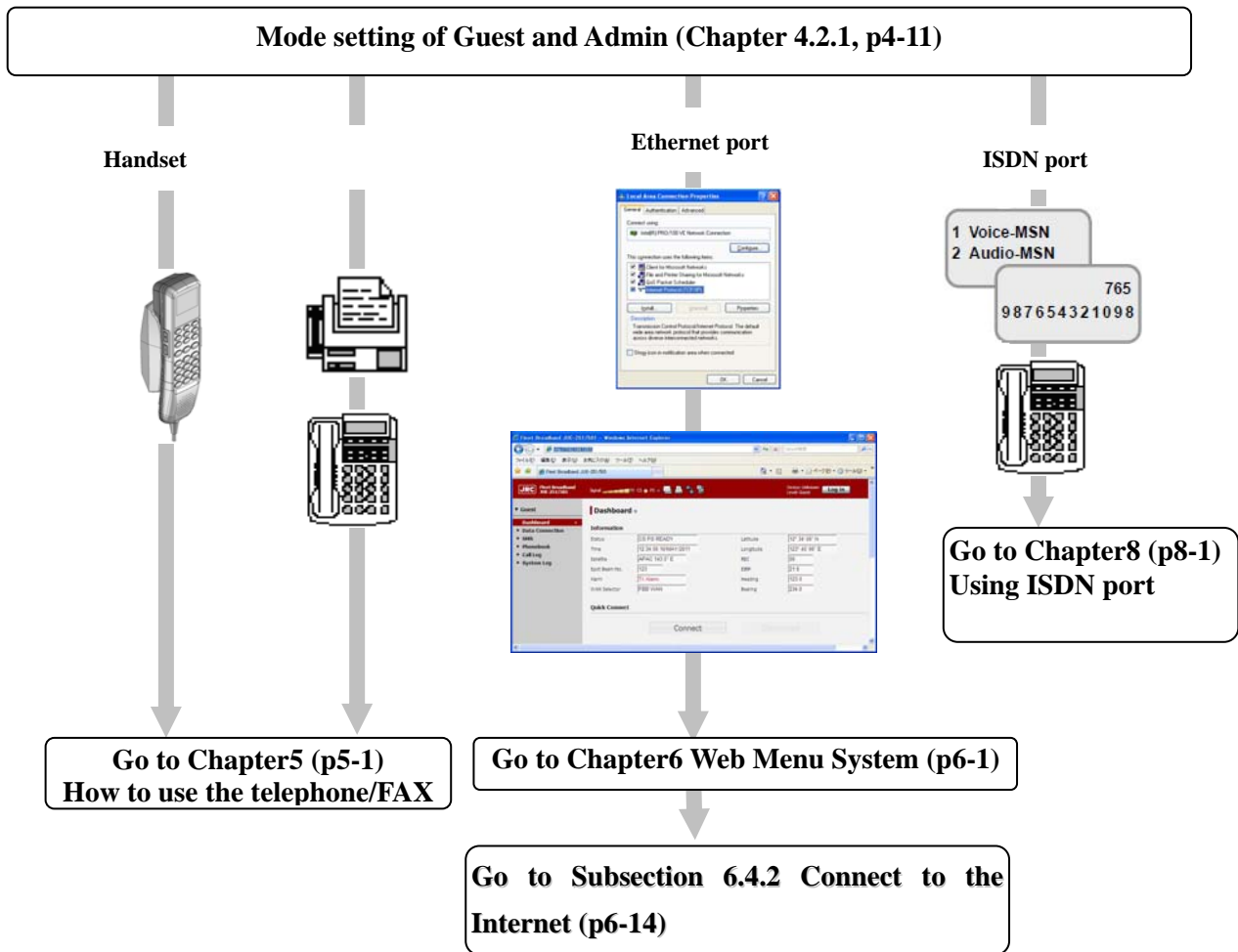

Fig. 4.2a Setting flow

NOTE

Following screen pops-up for a moment and returns to previous action/screen when wrong operation/entering is carried out from Handset.

Error

Fig. 4.2b Setting error screen

4.2.1 Mode setting of Guest and Admin

Guest user can perform the daily operation of the JUE-501/JUE-251.

Admin user can access additional functions like setup of the JUE-501/JUE-251 and information control.

When power switch is pressed only, the user logs in as a Guest user.

To operate the Admin user-limited menu described [5.1.5 Adjusting Handset], [6.5 Menus for Admin Users (Web)] or [7.9 Admin menu (Handset)] of this Manual, Log-in with secret code of Admin user is required.

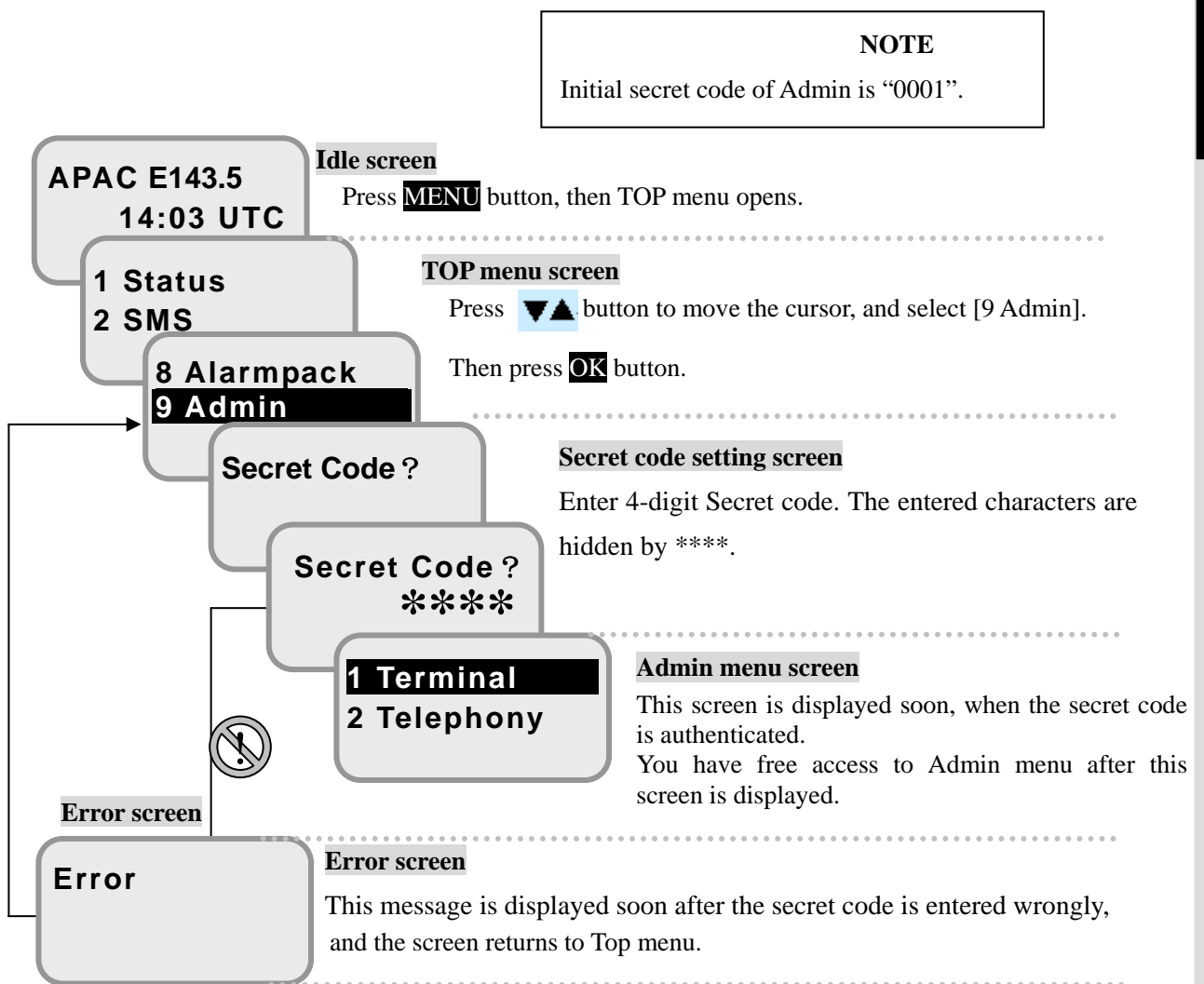



Fig. 4.2.1 Mode setting of Guest/Admin user

NOTE

* Return to Idle screen by pressing **CLR** button several times or pressing  (On-hook) button once to quit Admin user mode.

4. Getting started

4.2.2 Setting outgoing service type

In this section, setting the outgoing service types for TEL ports and ISDN port is explained.

The service type set here is used as the default for making a call on the port. Select the outgoing service type for each port by following the terminal device (telephone or FAX) being connected to each port.

Open [9 Admin] menu by the sequence of [4.2.1] screen. Select [2 Telephony] menu, then [Telephony menu] screen will open. Select [1 Telephony], and open [Telephony setting item selection] screen. Select the port you want to set from [TEL1] ~ [TEL6] or [ISDN] and open [TEL menu] (or [ISDN menu]) screen. Then, select [3 Out Type] and choose outgoing service type from [Voice], [Fax] and [Audio]. Press **OK** button and the screen returns to [TEL menu] (or [ISDN menu]) screen. The contents of each service type are explained below.

Voice	4kbps Voice service (for telephone).
Fax	64kbps 3.1kHz Audio service for Fax. (Internal call is unavailable.)
Audio	64kbps 3.1kHz Audio service for high quality phone. (Internal call is available.)

Regardless of setting here, Voice call can be made by adding * on the head of dialing sequence, and Fax/Audio call can be made by add ** on the head of dialing sequence. Refer to [5.2.1 Dial-up procedure for forced setting of service type](p5-30).

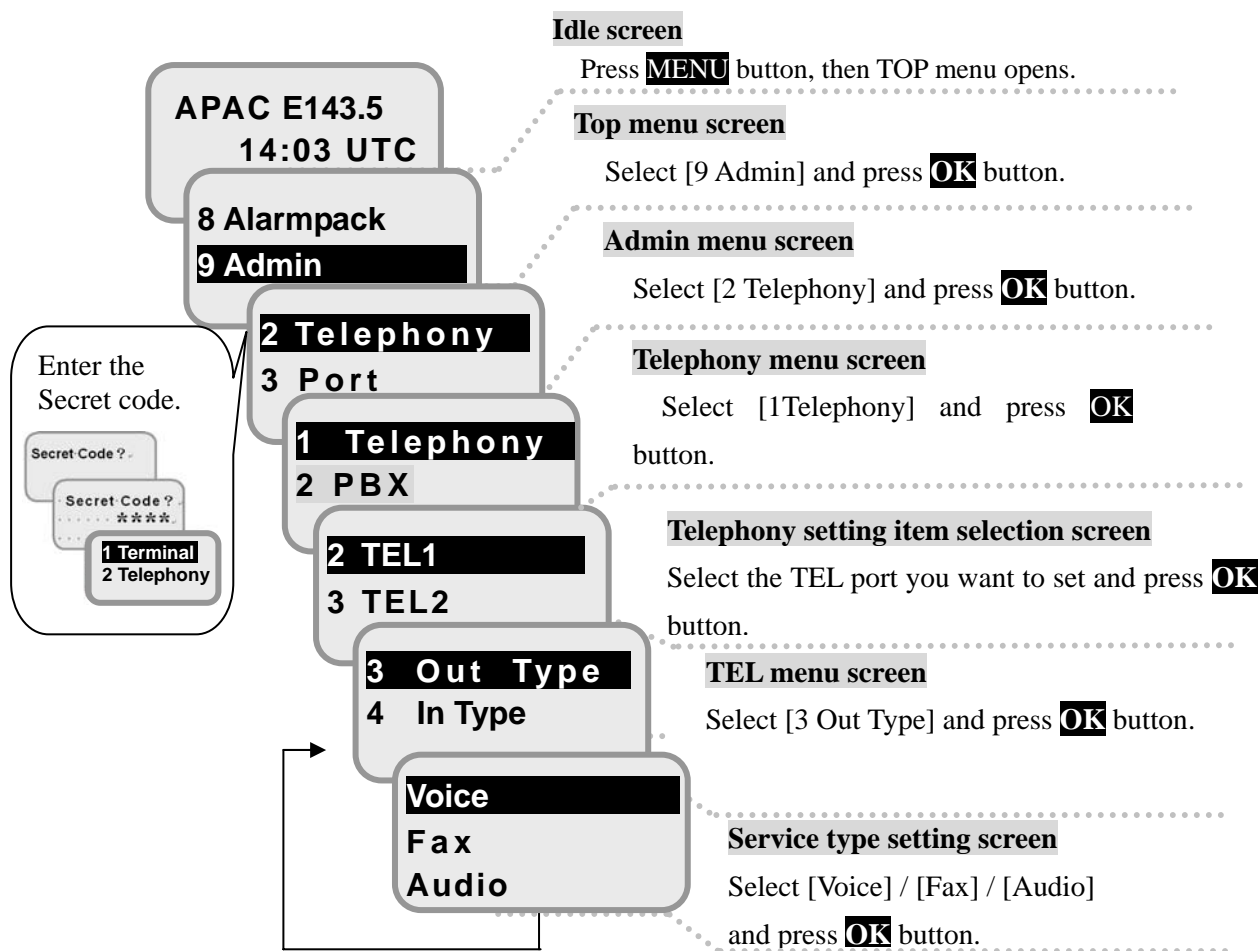

Fig.4.2.2 Setting service type menu

4.2.3 Setting incoming service type

In this section, setting the incoming service types for TEL ports and ISDN port is explained.

The service type set here is used for ring indication of receiving calls on the port. Select the incoming service type for each port by following the terminal device (telephone or FAX) being connected to each port.

Open [9 Admin] menu by the sequence of [4.2.1] screen. Select [2 Telephony] menu, then [Telephony menu] screen will open. Select [1 Telephony], and open [Telephony setting item selection] screen. Select the port you want to set from [TEL1] ~ [TEL6] or [ISDN] and open [TEL menu] (or [ISDN menu]) screen. Then, select [4In Type] and choose incoming service type from [Voice], [Fax], [Audio], [Voice/Fax] and [Voice/Audio]. Press **OK** button and the screen returns to [TEL menu] (or [ISDN menu]) screen. The contents of each service type are explained below (same with those of outgoing).

Voice	4kbps Voice service (for telephone).
Fax	64kbps 3.1kHz Audio service for Fax. (Internal call is unavailable.)
Audio	64kbps 3.1kHz Audio service for high quality phone. (Internal call is available.)
Voice/Fax	Both of 4kbps Voice service and 64kbps 3.1kHz Audio service for Fax.
Voice/Audio	Both of 4kbps Voice service and 64kbps 3.1kHz Audio service for high quality phone.

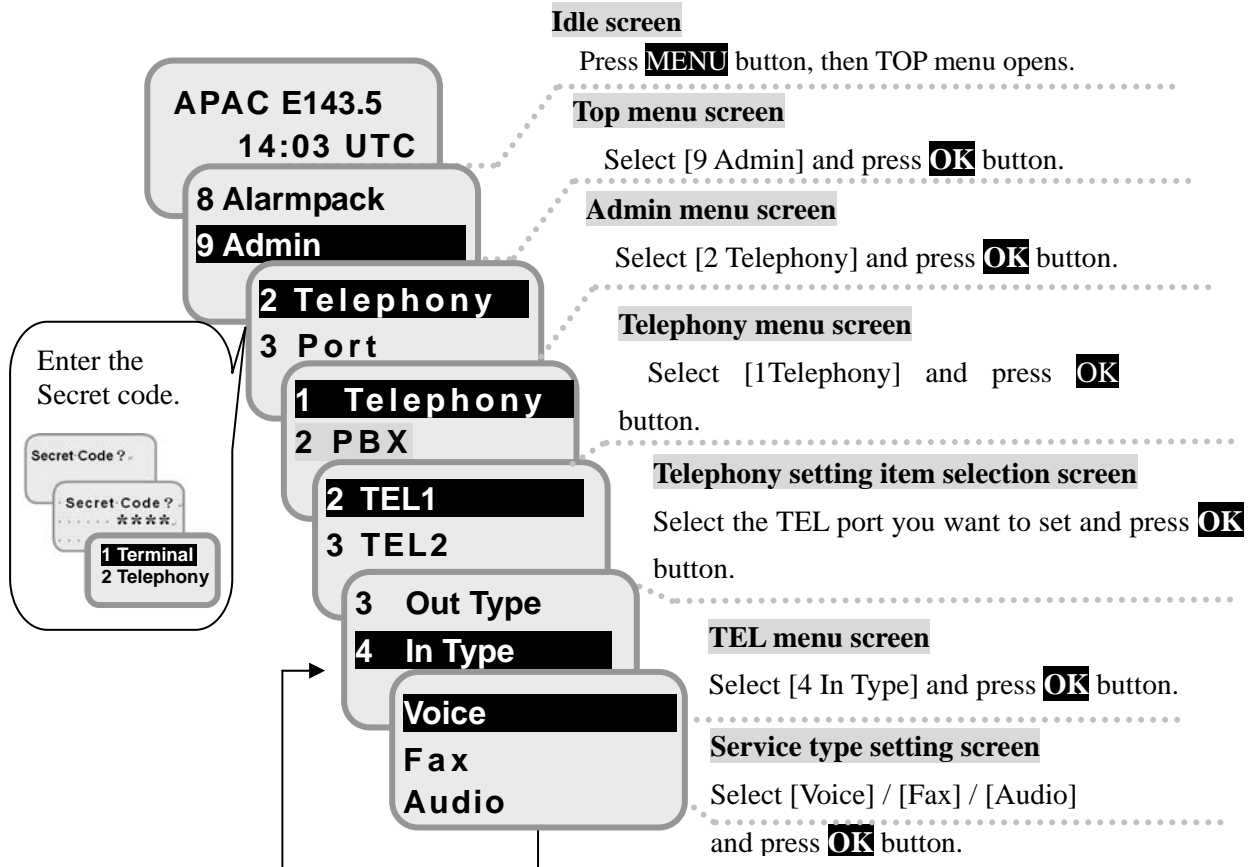



Fig.4.2.2 Setting service type menu

4. Getting started

4.2.4 Setting satellite search

In this section, setting of Satellite search is explained. Select [3 Satellite] from [Top menu], and select [1 Satellite] from displayed [Satellite] menu screen.

Current setting is displayed with * mark on its line head. To change it, move the cursor by  buttons, and press **OK** button (by selecting [Auto], suitable satellite is automatically chosen).

JUE-501/JUE-251 automatically acquires the satellite which is suitable for communication from the ship and which has high-elevation. However, the acquisition may fail because of a blocking due to affection of an antenna and a blockage. In this case, Handset shows “SEARCH NG” at the lowest line of the Handset screen or the antenna icon starts blinking at the top line. Select available satellite which is able to communicate and is not blocked.

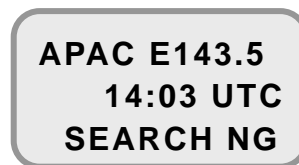

Fig. 4.2.3b SEARCH NG status of Idle screen

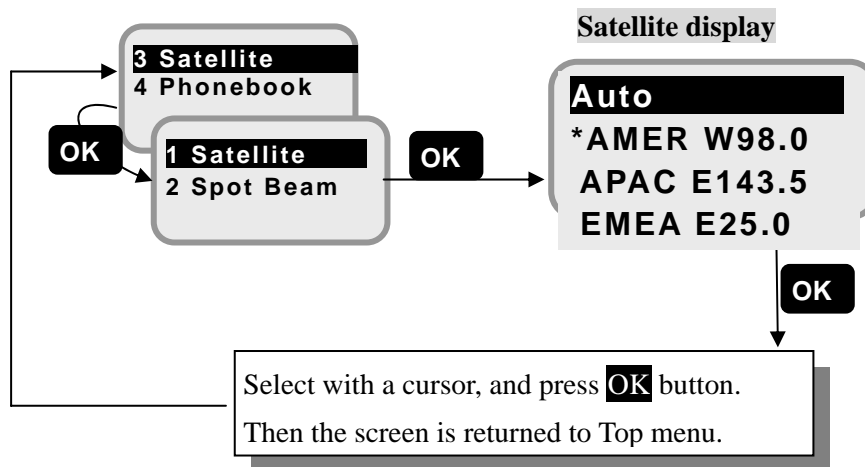

Fig. 4.2.3a Flow of Satellite selection

* Although there is nothing wrong with JUE-501/JUE-251, selecting satellite makes some noise on ADE.

* Handset will display the suitable satellites from the operating satellites.

AMER W98.0	(Americas satellite)
APAC E143.5	(APAC satellite)
EMEA E25.0	(EMEA satellite)

5. How to use the Telephone / FAX

**In chapter 5.1(p5-6), the telephone functions with Handset listed below are explained.
(The capped number of each function is the chapter No.)**

- | | |
|--|---|
| 5.1.1 Making / Answering an outside call | 5.1.9 Holding on the line |
| 5.1.2 Using Phonebook (Speed Dial) | 5.1.10 Rejecting Incoming/Outgoing call
(call barring) |
| 5.1.3 Using Redial menu | 5.1.11 Displaying voice mail service number |
| 5.1.4 Adjusting voice volume and brightness | 5.1.12 Using a Secret Code |
| 5.1.5 Adjusting ringer volume/pattern,
and voice volume (Admin user only) | 5.1.13 Entry, change and deletion of Phone
Book |
| 5.1.6 Calling Internal Phone | 5.1.14 Displaying Call Log |
| 5.1.7 Forwarding a call from Handset to
terminal telephone | 5.1.15 Restricting Outgoing Call |
| 5.1.8 Handling Call Waiting | 5.1.16 Setting Call-Sound for Incoming Call |

**In chapter 5.2(p5-29), functions of TEL/FAX using the TEL ports are explained.
(The capped number of each function is the chapter No.)**

- | | |
|--|-----------------------------|
| 5.2.1 Dial-up procedure | 5.2.4 Handling Call Waiting |
| 5.2.2 Calling Internal Phone | 5.2.5 Holding on the line |
| 5.2.3 Forwarding a call to the other terminals | |

5. How to use the telephone/FAX

Dial-up procedure of the JUE-501/JUE-251

The telephone number dialed last is memorized in main unit. Redialing of telephone is simple. Refer to the procedure below.

Table 5a. Dial-up procedure of the JUE-501/JUE-251

Dial-up procedure of the JUE-501/JUE-251 (from terminal telephone/Handset)	
■ Regular calling	00 Country Code Area Code Subscriber's number # Example) Placing a call to +81-422-45-9xxx, in Japan → 0081422459xxx #
■ Speed Dialing	Speed Dialing number (2 digits or 3 digits) * # Example) Calling by a Speed Dial number 005 → 05 * # Calling by a Speed Dial number 083 → 83 * # Calling by a Speed Dial number 128 → 128 * #
■ Redial calling	00 * # (Last dialed number stored in each port is redialed)
■ Secret Code calling	Secret Code 00 Country Code Area Code Subscriber's number # Example) Placing a call with secret code 4321 , to +81-422-45-9xxx in Japan. → 43210081422459xxx #

Dial-up procedure for forced setting of service type

Just adding * or ** on the head of dialing sequence, user can easily set the service type (Voice or FAX) to each port, regardless of setup made at [6.5.2.1 Set up Port (p6-34)].

This is temporary setting, and available only for the transmission.

Only Voice service can be available on the Handset.

Table 5b. Dial-up procedure of the JUE-501/JUE-251, for forced setting of each service type

Using Voice service (4kbps Voice) temporarily

- Regular calling *00 Country Code Area Code Subscriber's number #
- Speed Dialing * Speed Dialing number * #
- Redial calling *00 * #
- Secret Code calling Secret Code *00 Country Code Area Code Subscriber's number #

Using FAX service (3.1kHz FAX) temporarily

- Regular calling **00 Country Code Area Code Subscriber's number #
- Speed Dialing ** Speed Dialing number * #
- Redial calling **00 * #
- Secret Code calling Secret Code **00 Country Code Area Code Subscriber's number #

Dial-up procedure for number display and non-display

In this menu, user sets whether notifying or not-notifying their number to the recipient by just adding 1+* or 2+* on the head of dialing sequence.

This is a temporary setting, and available only for the transmission.

Table 5c. Dial-up procedure for number display and non-display

Displaying number	
■ Regular calling	1 * 00 Country Code Area Code Subscriber's number #
■ Speed Dialing	1 * Speed Dialing number * #
■ Redial calling	1 * 00 * #
■ Regular calling with forced service type of Voice (4kbps Voice)	* 1 * 00 Country Code Area Code Subscriber's number #
■ Secret Code calling	Secret Code 1 * 00 Country Code Area Code Subscriber's number #
■ Secret Code calling with forced service type of FAX (3.1kHz FAX)	Secret Code * * 1 * 00 Country Code Area Code Subscriber's number #
Not displaying number	
■ Regular calling	2 * 00 Country Code Area Code Subscriber's number #
■ Speed Dialing	2 * Speed Dialing number * #
■ Redial calling	2 * 00 * #
■ Regular calling with forced service type of Voice (4kbps Voice)	* 2 * 00 Country Code Area Code Subscriber's number #
■ Secret Code calling	Secret Code 2 * 00 Country Code Area Code Subscriber's number #
■ Secret Code calling with forced service type of FAX (3.1kHz FAX)	Secret Code * * 2 * 00 Country Code Area Code Subscriber's number #

Before using Handset

You can operate the JUE-501/JUE-251 with the Handset both on-hooked and off-hooked to the cradle.

1. Off-hook the Handset from the cradle (Off-hook mode)

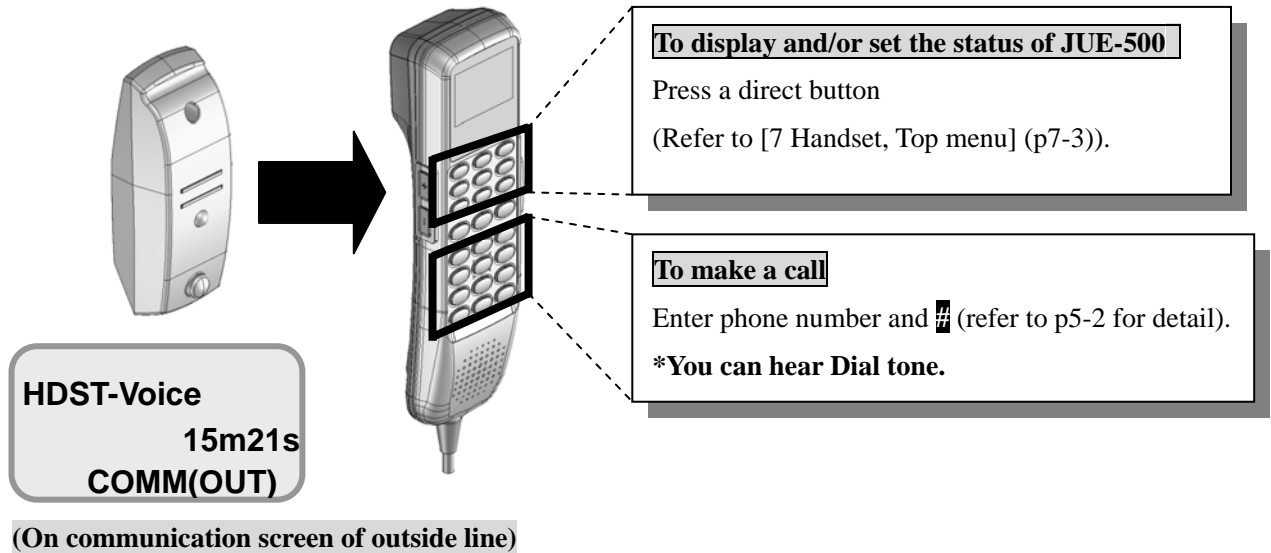

Fig. 5a Operation on Off-hook mode

2. On-hook the Handset on the cradle (On-hook mode)

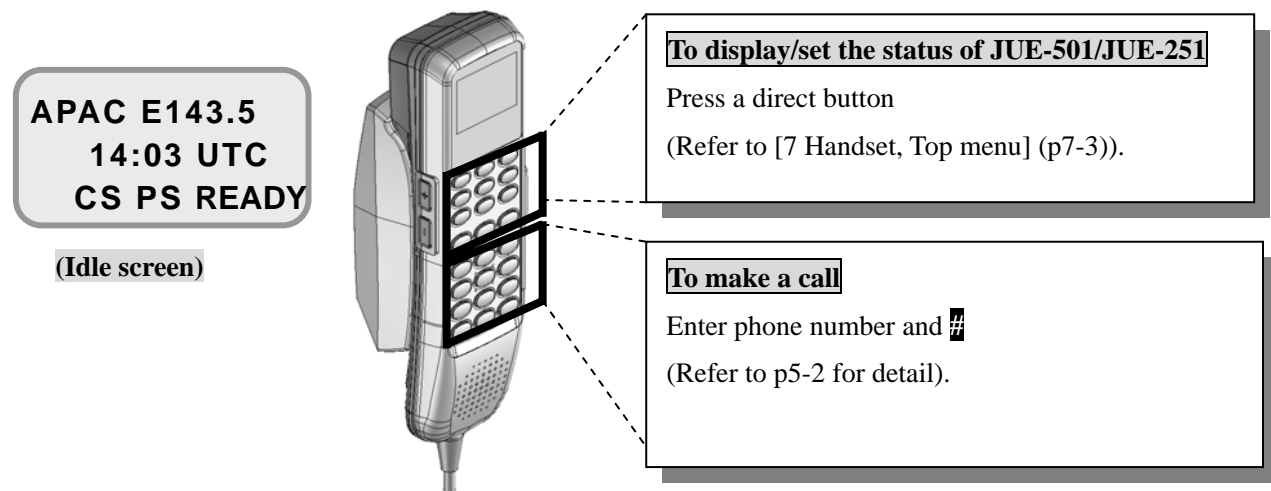

Fig. 5b Operation on On-hook mode

In this Chapter, operations based on the On-hook mode are explained.

Making a call on Handset without Secret Code is not available, when the Secret code setting is turned on.

5.1 Handset

5.1.1 Making/ Answering an outside call

Making an outside call

Hook off the Handset and press the number followed by **#** button.

When the party answers the call, [On Communication screen for outside call] is displayed. Enjoy your conversation with the party.

Return Handset to the cradle when the telephone call ends. [Disconnection screen] is displayed for 15 seconds with Cause Code and duration of communication. After the call has been completed, the display returns to [Idle screen].

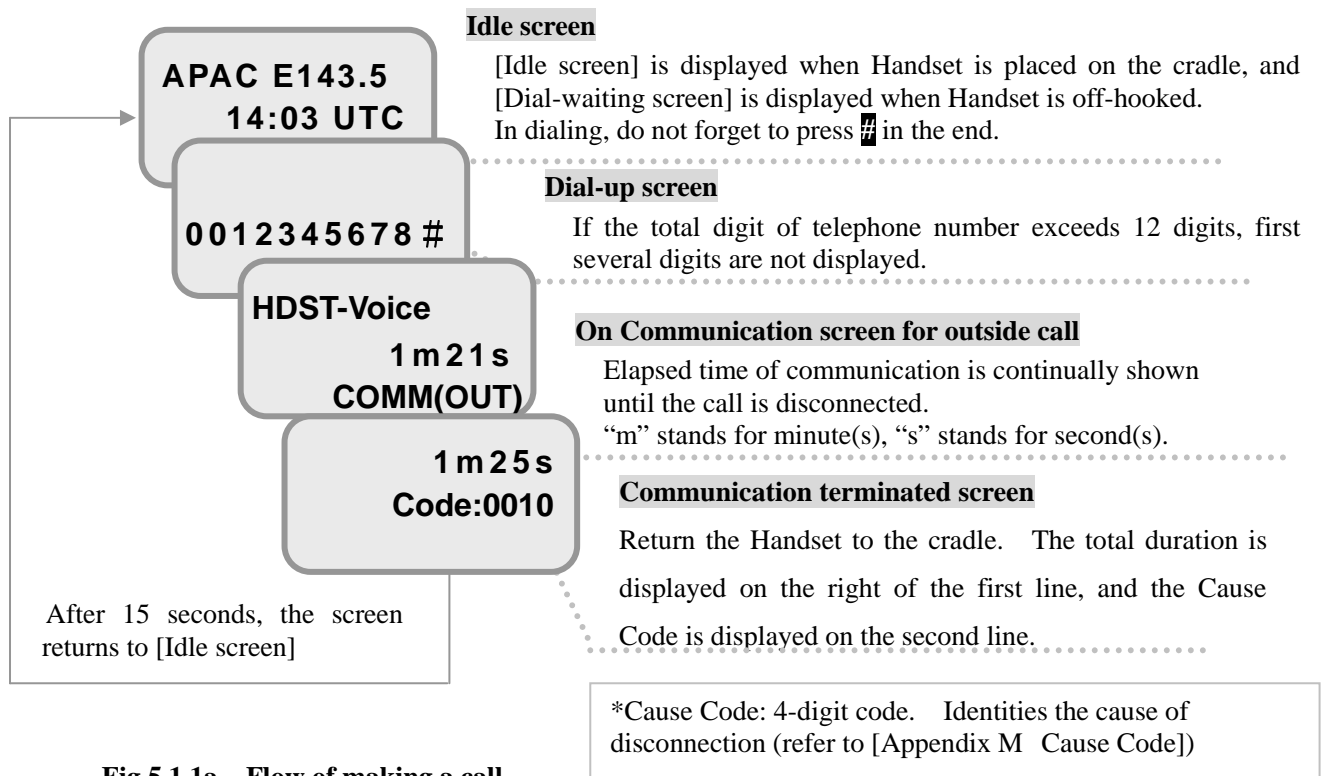

Fig.5.1.1a Flow of making a call

■ Dial-up procedure **00 Country Code Area Code Subscriber's Number #**
 Example) Placing a call to +81422-45-9xxx in Japan → **0081422459xxx#**

Answering the phone

If the JUE-501/JUE-251 receives a call from outside, ring tone will sound and the screen changes to [Arrival screen for outside call].

Take up the Handset from the cradle, then you can talk with the party. The screen will change to [On communication screen for outside call]. After the disconnection, return the Handset to the cradle.

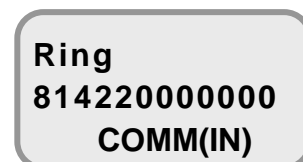

Fig.5.1.1b Arrival screen for outside call

NOTE
 Voice of landside might be distorted or interrupted if the JUE-501/JUE-251 is used under a remarkably noisy environment, for example, in a small and high-speed ship.

5.1.2 Using Phonebook (Speed dial)

Register the phone numbers before the Phonebook (Speed dial) is used.
Refer to [5.1.13 Entry, change and deletion of Phonebook](p5-21).

To make a call with Speed dial from Handset

Press  button in Idle screen.

[Phonebook address screen] is displayed.

Scroll the screen with  buttons, select the address with the cursor and press **OK** button.
(It is also available by below mentioned **Quick procedure for Speed dialing**).

Example) Placing a call to Mr. SMITH, who has been registered in Phonebook No.006.

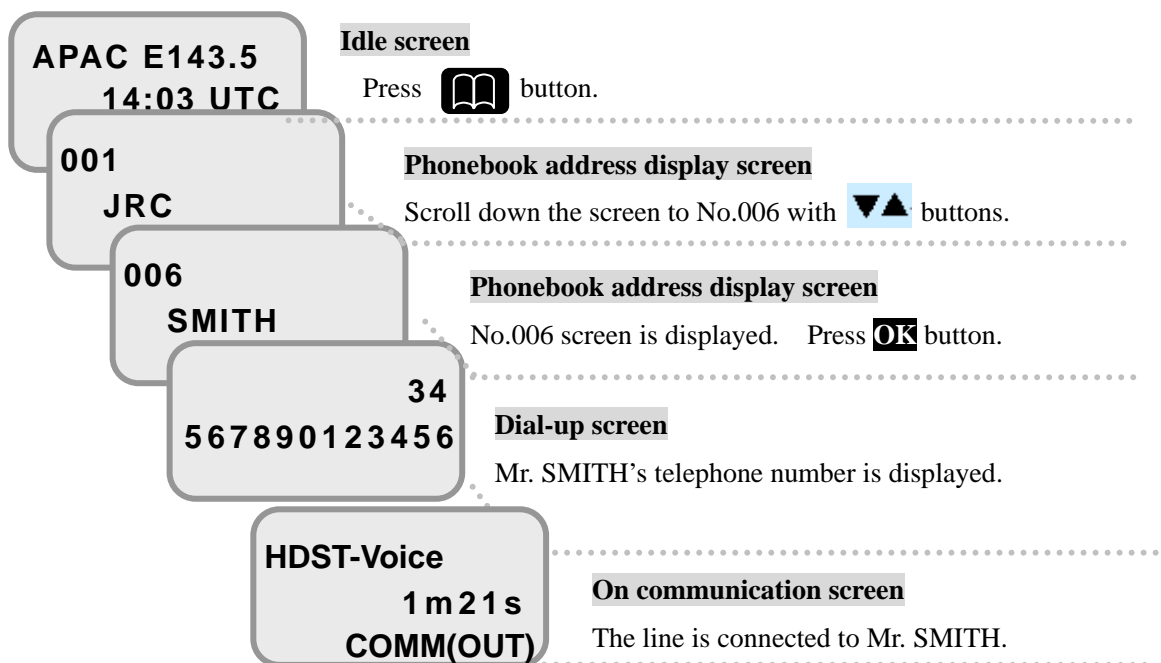



Fig.5.1.2 Flow of using Phonebook (Speed Dial)

Quick procedure for Speed dialing

■ Speed Dialing

Speed Dialing number  

Example) Placing a call to Speed Dialing No.001→**01**  

Placing a call to Speed Dialing No.018→**18**  

Placing a call to Speed Dialing No.113→**113**  

5. How to use the telephone/FAX

5.1.3 Using Redial menu

Redial menu displays the dial number of the last 50 calls.

Example) To display 0081-422-45-9xxx with the Redial list, scroll through the screen with  buttons, and place a call to the number using the Redial function.

Press  buttons with the display on [Idle screen], the screen will change to [Redial List screen].

Press  buttons until desired dial number is displayed.

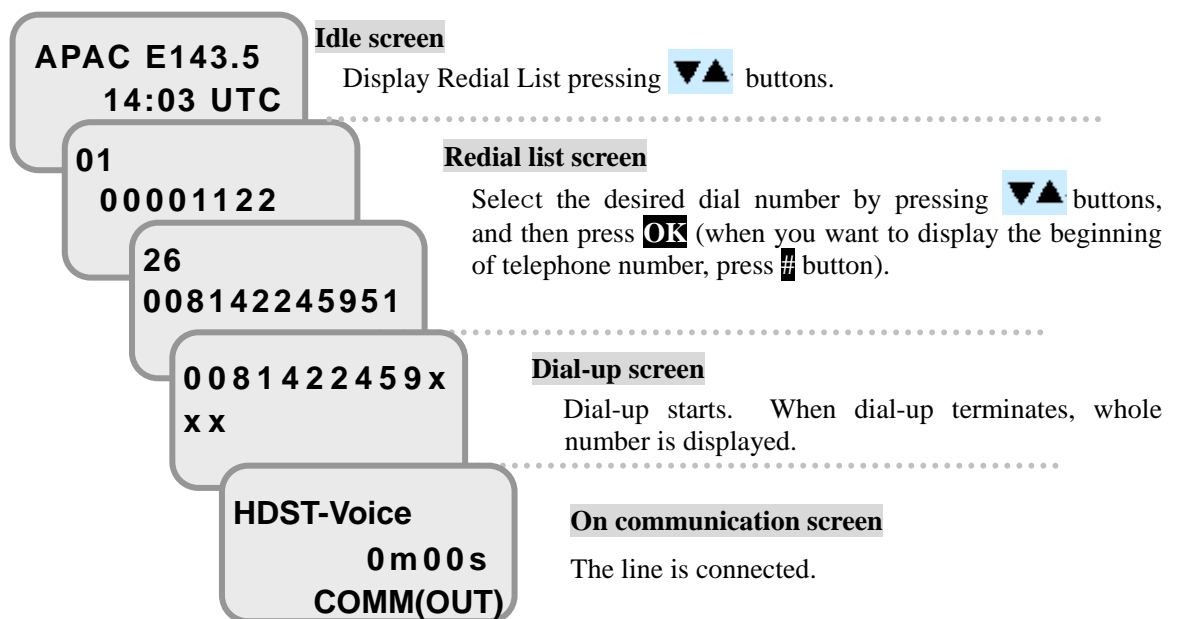

Fig.5.1.3 Flow of using Redial menu

5.1.4 Adjusting voice volume, backlight brightness, and ringer volume

Quick adjustment of voice volume (Handset status: Off-hook mode)

To adjust the voice volume, press $\boxed{+}\boxed{-}$ buttons on the left side of the Handset, during the communication.

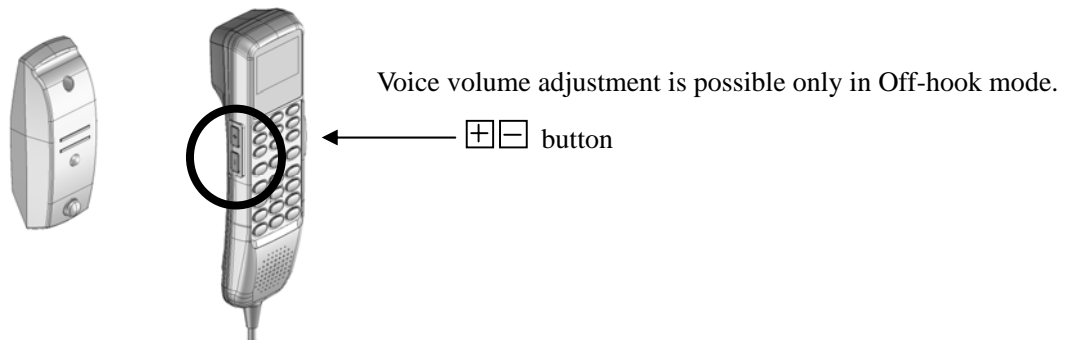

Fig.5.1.4a Quick adjustment of voice volume using $\boxed{+}\boxed{-}$ buttons

Quick adjustment of backlight brightness (Handset status: On-hook/Off-hook mode)

To adjust the brightness of the screen, press $\boxed{+}\boxed{-}$ buttons on the left side of the Handset. Both modes are available, On-hook mode (placing the Handset on the cradle, or pick up the Handset and operating a Menu button) or Off-hook mode.

Quick adjustment of ringer volume (Handset status: On-hook mode)

To adjust the ringer volume, press $\boxed{+}\boxed{-}$ buttons on the left side of the Handset, while it is ringing.

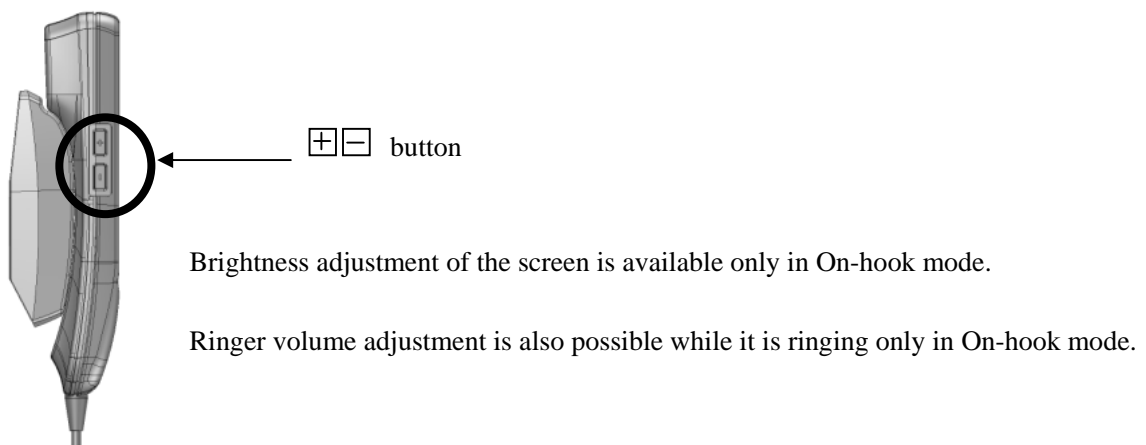

Fig.5.1.4b Quick adjustment of backlight brightness and ringer volume using $\boxed{+}\boxed{-}$ buttons

These adjustments are only temporary. To make permanent adjustments, please refer to the [5.1.5 Adjusting ringer volume/pattern/voice volume/backlight brightness (Admin user only)](p5-10).

5. How to use the telephone/FAX

5.1.5 Adjusting ringer volume /pattern/voice volume/backlight brightness (Admin user only)

Adjusting the ringer volume

Ringer volume can be adjusted from the menu of the Handset.

Refer to below flow chart, open the menu screens and start the setup.

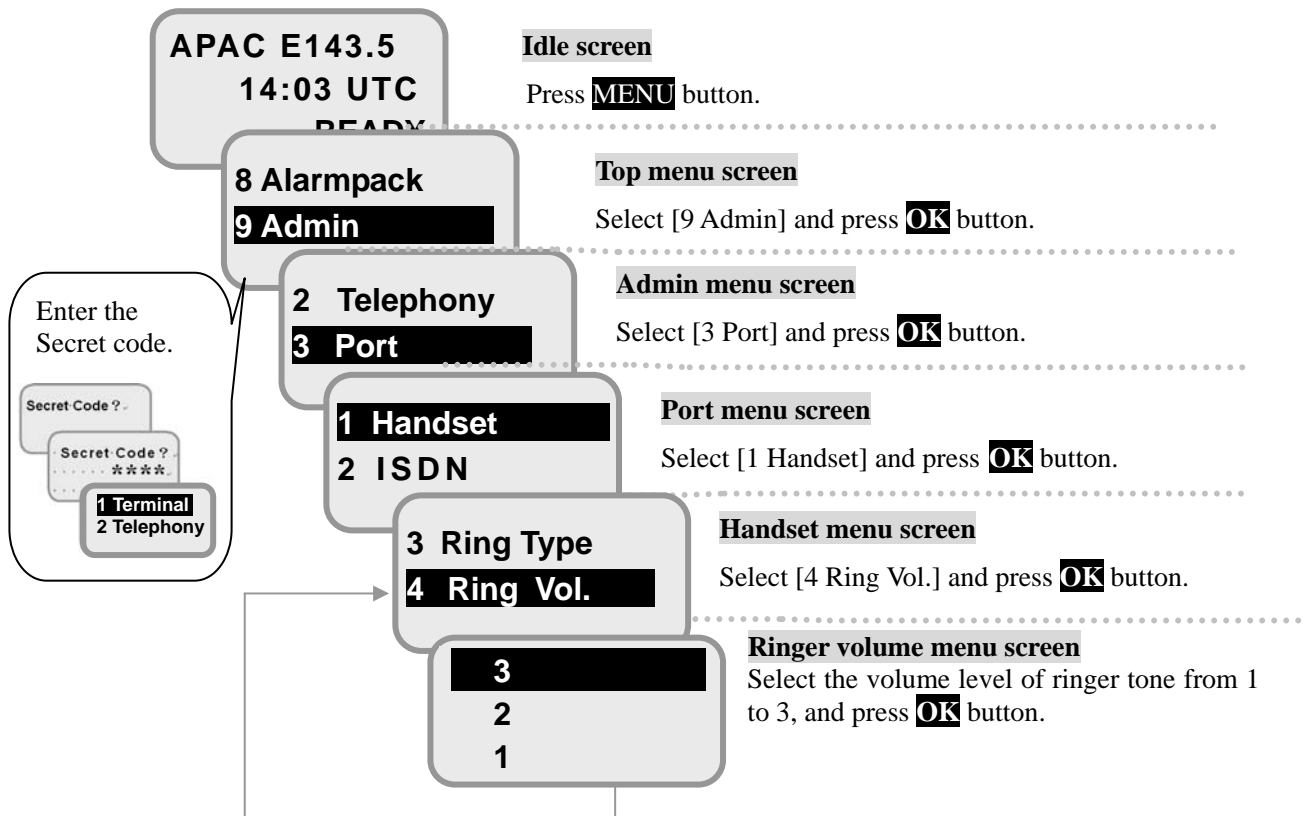

Fig.5.1.5a Flow of setting ringer volume

Selecting the ringer type

The pattern of ringer tone can be selected from six types, in the same way as above.

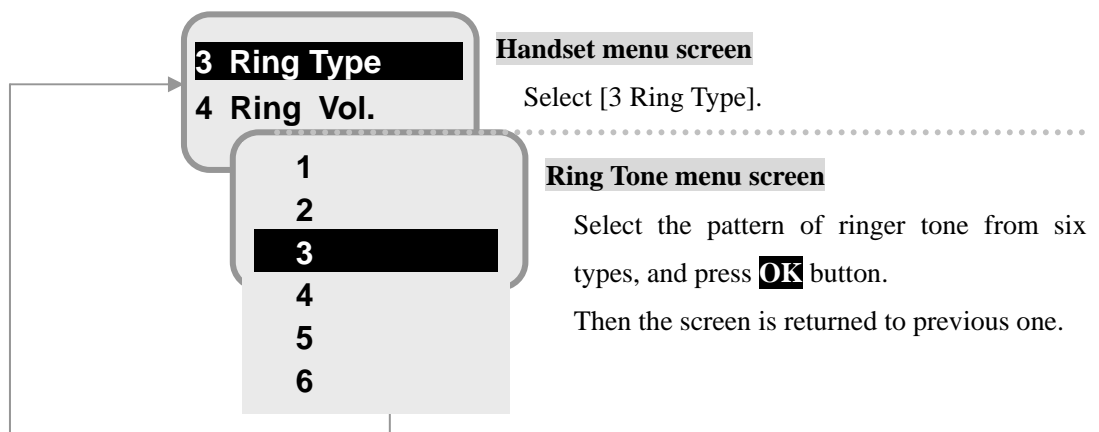

Fig.5.1.5b Flow of setting pattern of Ring Type

Adjusting the voice volume and the backlight brightness by the buttons of Handset

Voice volume can be adjusted using the \oplus \ominus buttons on the left side of Handset (refer to [5.1.4 Adjusting voice volume and the backlight brightness](p5-9)).

To change the default voice volume, follow the way shown below.

Setting voice volume from Handset screen

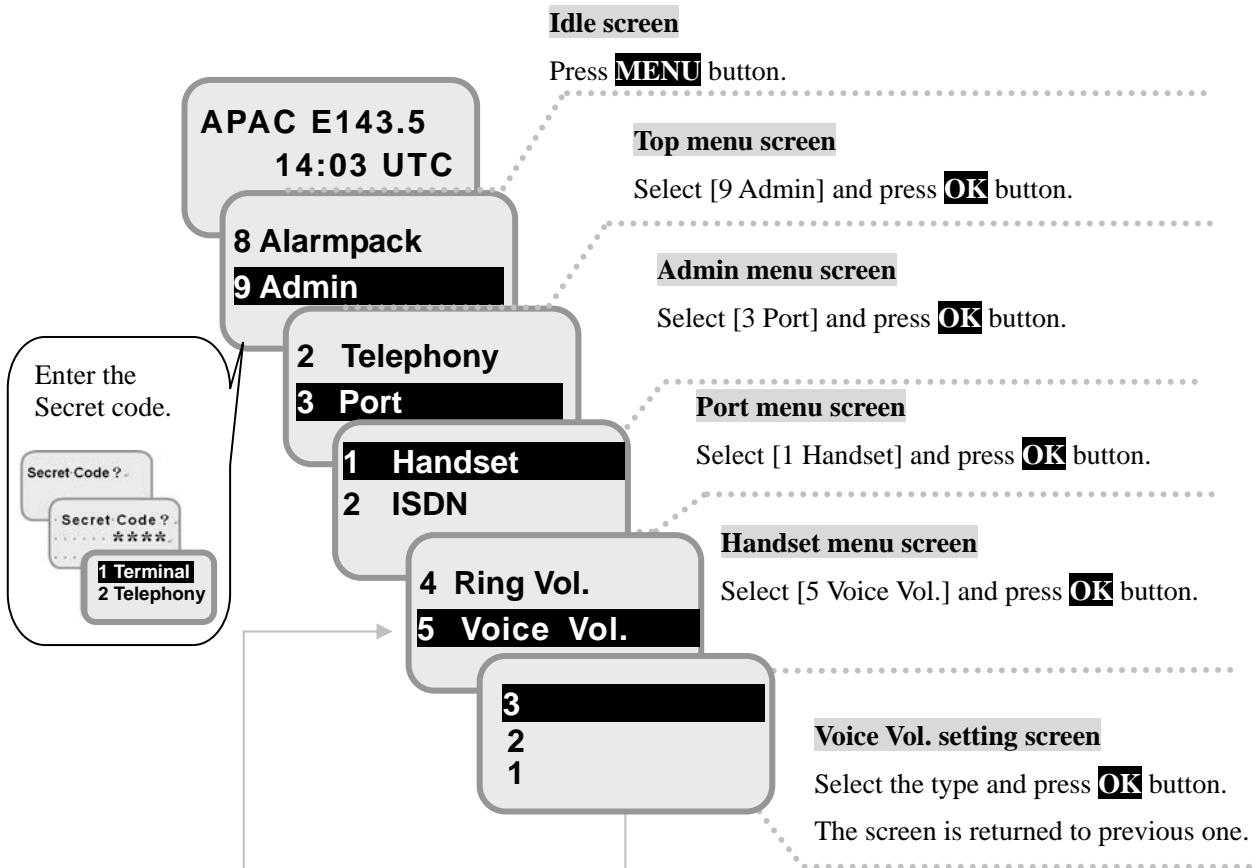

Fig.5.1.5c Flow of setting voice volume

Setting backlight brightness (in Port Menu screen)

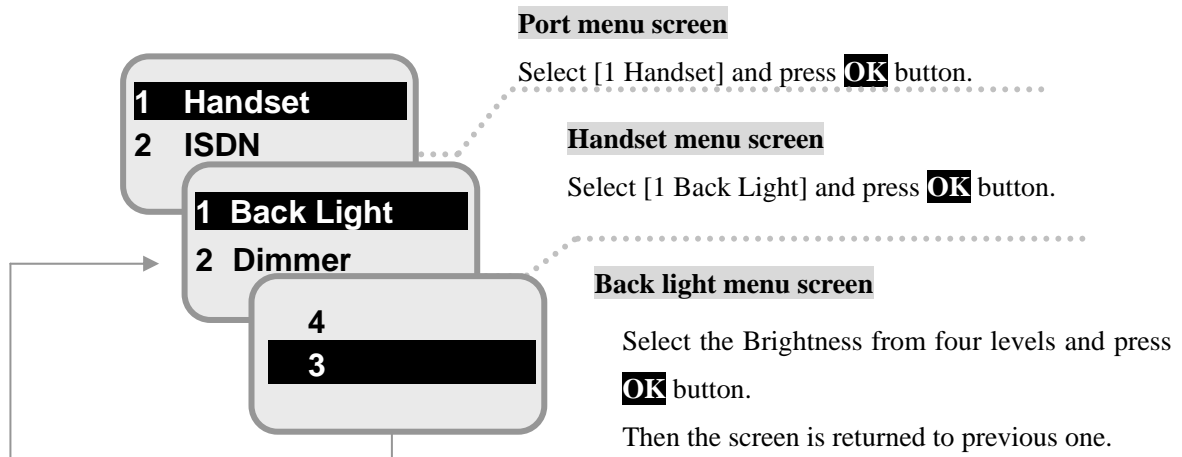

Fig.5.1.5d Flow of setting backlight brightness

5. How to use the telephone/FAX

5.1.6 Calling Internal Phone

Hook off the Handset and press **#** and the extension number listed in table below.

Table 5.1.6 Allocated Extension Number

Device	Allocated number
Handset	000
TEL1~TEL6	001~006
All TEL ports and Handset	099
ISDN (Set PBX-MSN. Refer to p6-40.)	401
All	999

When the party answers the call, [On Communication screen for Internal Phone] is displayed.

Return Handset to the cradle when the telephone call ends. [Disconnection screen] is displayed for 15 seconds with Cause Code and duration of communication. After the call has been completed, the display returns to [Idle screen].

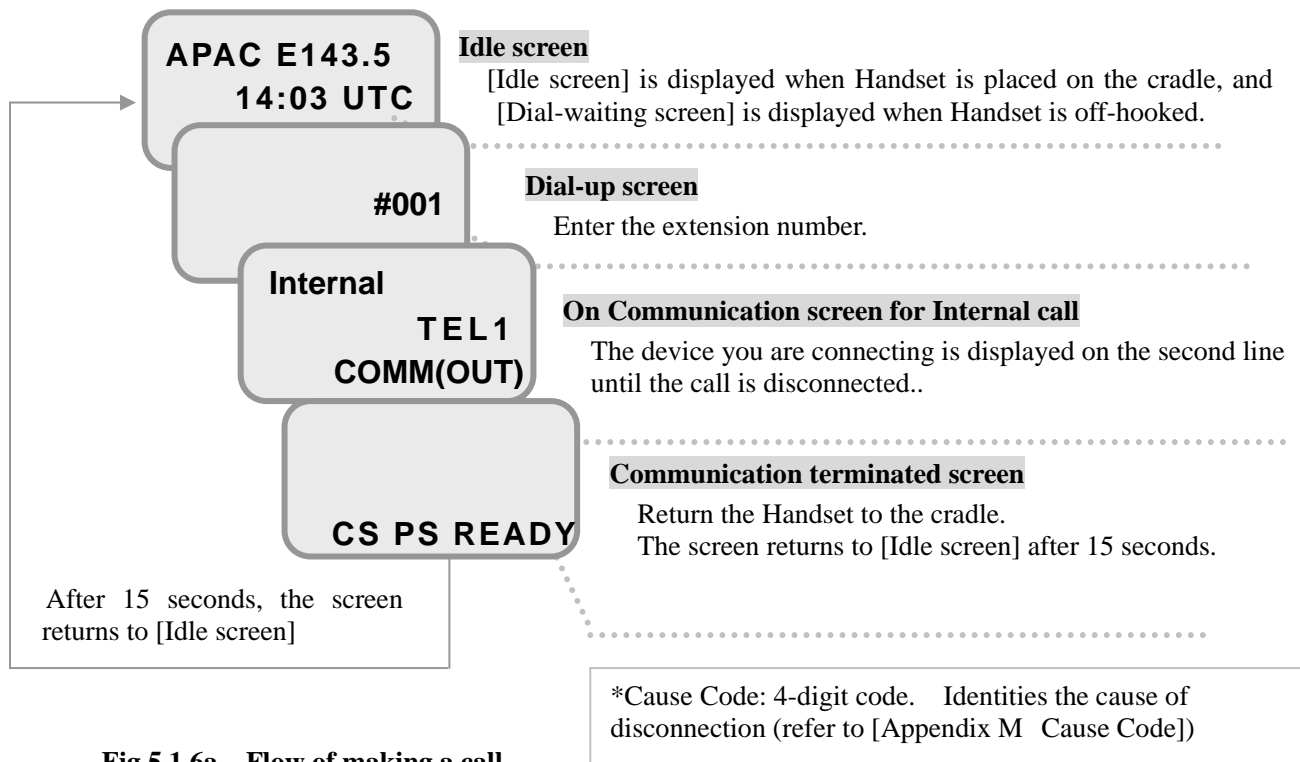

Fig.5.1.6a Flow of making a call

Answering the Internal call

If the Handset receives an internal call, ring tone will sound and the screen changes to [Arrival screen for internal call].

Take up the Handset from the cradle, then you can talk with the party. The screen will change to [On communication screen for internal call]. After the disconnection, return the Handset to the cradle.

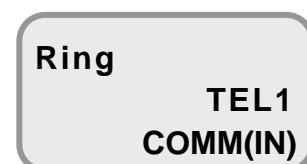

Fig.5.1.6b Arrival screen for internal call

5.1.7 Forwarding a call from Handset to terminal telephone

JUE-501/JUE-251 has two ways to pass a call to the terminal telephones which connected to BDE. One is Quick Forwarding and another is Talk Forwarding.

To forward a call to outside call automatically, refer to [6.5.2.3 Set Telephone Supplementary Service (p6-37)] or [7.9.2.3 Suppl. setting (p7-50)].

Quick Forwarding

Quick Forwarding forwards an outside call to local terminals connected to the BDE without any talk on internal call.

To use Quick Forwarding, press ****** and the extension number during the communication. Press the On hook button () or place the Handset on the cradle, after you heard the beep tone. Extension numbers of the JUE-501/JUE-251 are designated as follows.

Table 5.1.9 Allocated Extension Number

Device	Allocated number
Handset	000
TEL1~TEL6	001~006
All TEL ports and Handset	099
ISDN (Set PBX-MSN. Refer to p6-40.)	401
All	999

Example) Terminal telephone connected with TEL port 1.....**+001+[On-hook]

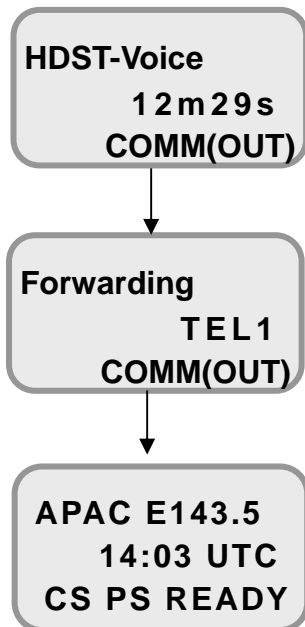

On communication screen

Press ****** and the **extension number**(to be transferred).
 Press **** 001** to transfer to the terminal telephone connected with TEL 1 port.
 Press **** 401** to transfer the telephone connected with ISDN port.
 Press the On hook button () or place the Handset on the cradle, after you heard the beep tone.

The specified terminal and Handset will ring the same time. To cancel forwarding, take the call on Handset again.

Idle screen (after the call is picked up by destination)

Ring tone sound stops when the forwarded destination picks up the call. The screen will back to the Idle screen.

To cancel forwarding mode, press ****+*****.
 Forwarding mode will be cancelled and return to [on communication status]

5. How to use the telephone/FAX

Talk Forwarding

Talk Forwarding forwards an outside call to local terminals connected to the BDE after a talk on internal call. The outside caller will wait until your conversation will end hearing the suspension tone.

To use Talk Forwarding, press **0*** and the extension number during the communication. The specified terminal will ring and you can talk with the forwarding destination on internal call. Press the On hook button () or place the Handset on the cradle after your internal call finished. Then the forwarding destination and the outside caller will start talking.

Extension numbers of the JUE-501/JUE-251 are designated as follows.

Table 5.1.9b Allocated Extension Number

Device	Allocated number
Handset	000
TEL1~TEL6	001~006
All TEL ports and Handset	099
ISDN (Set PBX-MSN. Refer to p6-40.)	401
All	999

Example) Terminal telephone connected with TEL port 1..... **0*+001** → internal call → [On-hook]

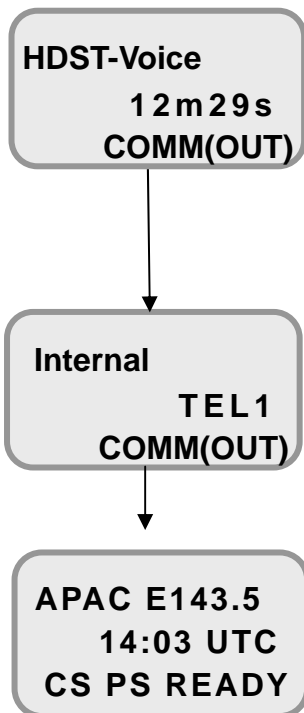

On communication screen

Press **0*** and the **extension number**(to be transferred).
 Press **0*001** to transfer to the terminal telephone connected with TEL port 1.
 Press **0*401** to transfer the telephone connected with ISDN port.

On communication screen for Internal call

The specified terminal will ring and on communication screen for internal call will be displayed after your party takes the phone. Press the On hook button () or place the Handset on the cradle, after your internal call finished.

Idle screen

The specified terminal will start communication with the outside call. The screen back to the idle screen.

To cancel forwarding mode, press ***#+###**.
 Forwarding mode will be cancelled and return to [on communication status]

5.1.8 Handling Call Waiting

You may hear a call waiting Indication during talking on the phone. The call waiting Indication tone is two beeps every three seconds. To handle call waiting with Handset, use **FN** (Function) button on right side of Handset. Enable / disable call waiting is performed by Web setting (refer to [6.5.2.3 Set Telephone Supplementary Service (p6-37)]).

Follow the procedure below as desired.

Clear the current call, and accept the waiting call.

Press **FN 1 #**, during the call waiting indication is ringing.

Hold the current call, and accept the waiting call.

Press **FN 2 #**, during the call waiting indication is ringing.

To exchange the held call for the active call, press **FN 2 #**.

To clear the active call and back to the held call, press **FN 1 #**.

Ignore the waiting call.

Just ignore the waiting call indication (take no action).

Reject the waiting call.

Press **FN 0 #**.

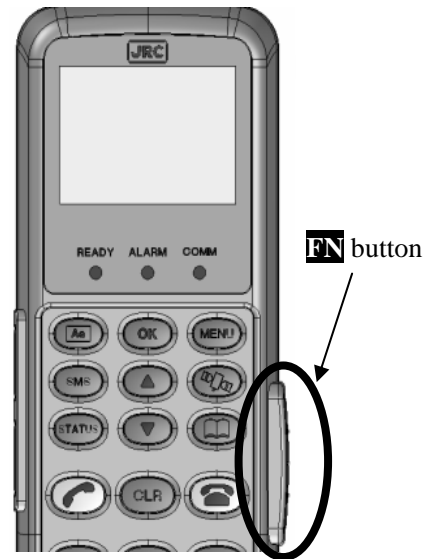

Fig.5.1.7 FN button

NOTE

The BGAN system supports only one Call Waiting at the same time.

These functions are not supported by BDE-APP 1.03.
A new version supporting them is planned to be provided soon.

5. How to use the telephone/FAX

5.1.9 Holding on the line

To hold a call on with Handset, use **FN** (Function) button on right side of Handset.

Follow the procedure below as desired.

Place a call on hold.

Press **FN 2 #**, during the call is active.

Place the existing call on hold and establish a new call.

Press **FN** and dial the second phone number followed by **#**.

Example) Establishing new call to +81422-45-9xxx in Japan

→ **FN 0081422459xxx #**

Exchange held call for active call.

Press **FN 2 #**.

Clear the active call and back to the held call.

Press **FN 1 #**.

Clear the holding call (if no waiting call exists).

Press **FN 0 #**.

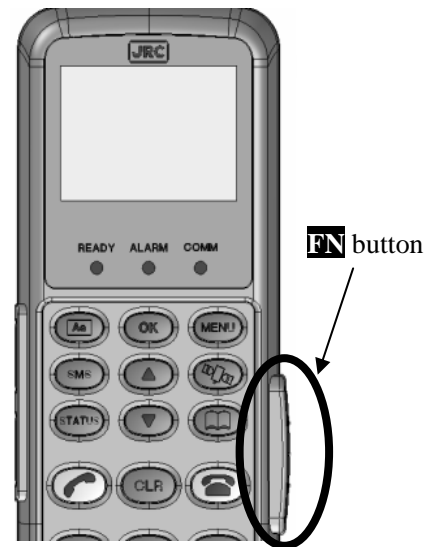

Fig.5.1.8 FN button

These functions are not supported by BDE-APP 1.03.
A new version supporting them is planned to be provided soon.

5.1.10 Rejecting Incoming/Outgoing call (call barring)

To reject Incoming/Outgoing call, you need to setup call barring function. It can be set by Web interface also (refer to [6.5.2.3 Set Telephone Supplementary Service (p6-37)]).

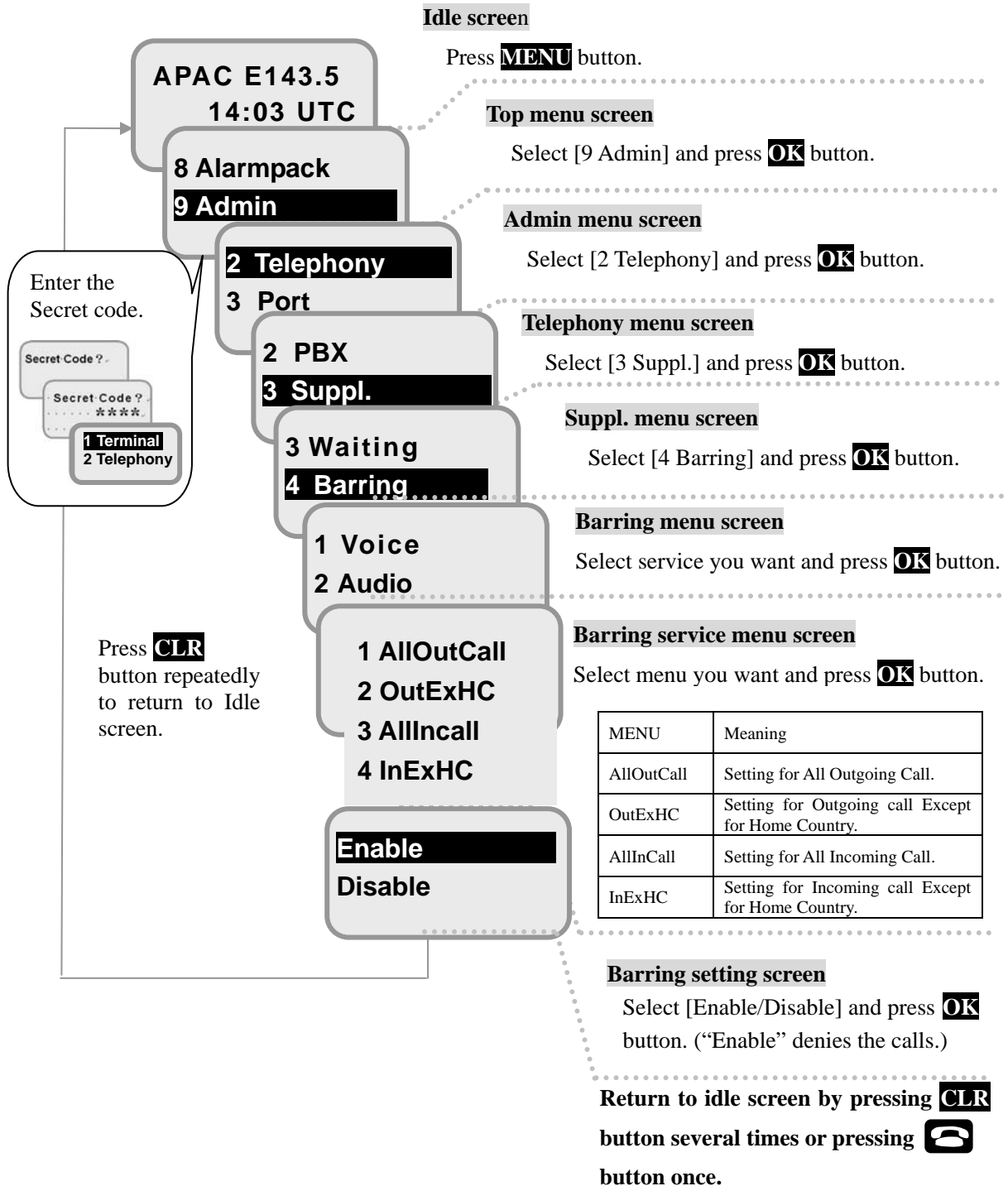

Fig.5.1.10 Flow of setting Call Barring

5. How to use the telephone/FAX

5.1.11 Displaying voice mail service number

You may get notification of voice mail by SMS. Then check your voice mail service number and dial the number. You can get message from the service center. The number can be checked by Web interface also (refer to [6.5.2.3 Set Telephone Supplementary Service (p6-37)]).

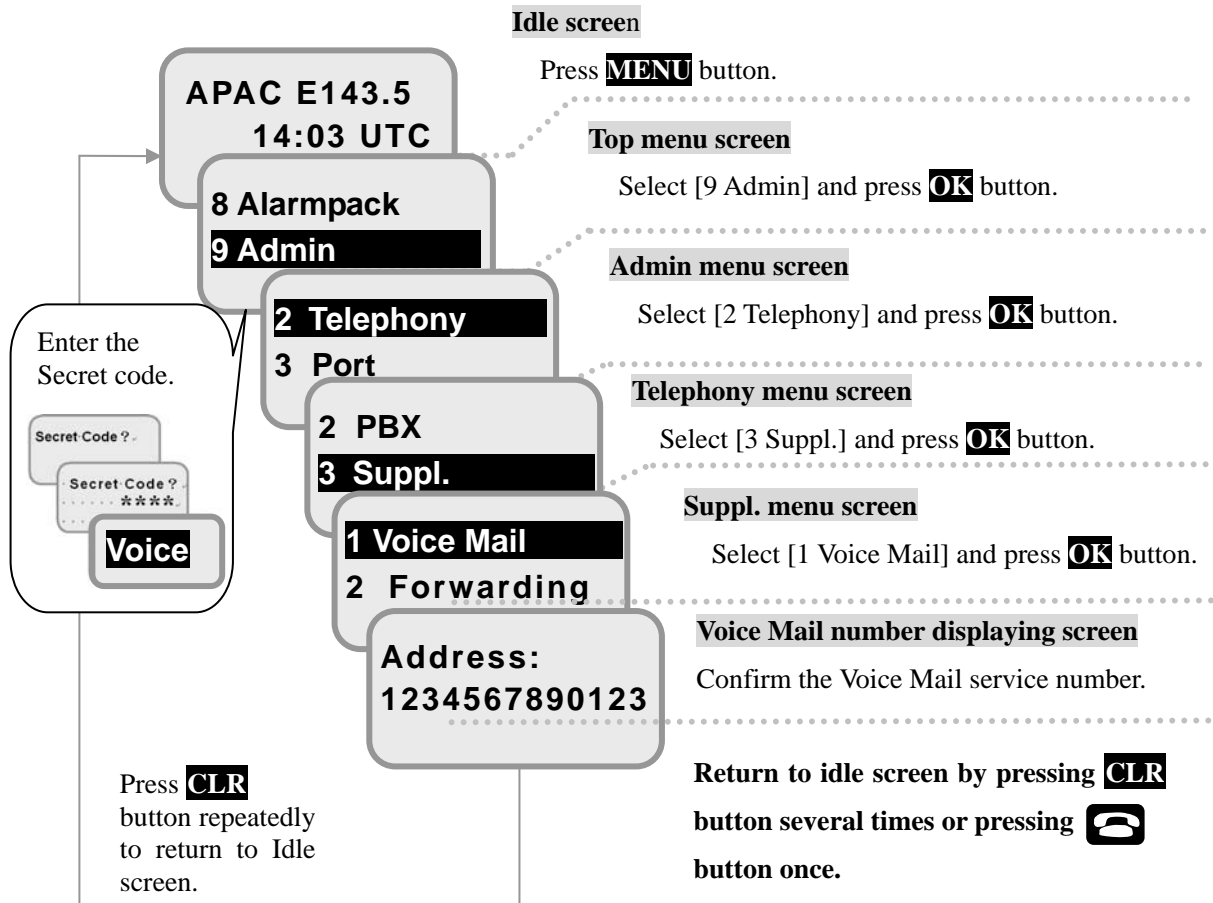

Fig.5.1.11 Flow of displaying Voice Mail service number

■ Dial-up procedure

00 Voice Mail service Number #

Example) Placing a call to 1234567890123 →001234567890123#

5.1.12 Using a Secret Code

Setup procedure

Enable the Secret Code to use Secret Code

To use the Secret Code, port setting is required.

NOTE

Once the Secret Code is set on a telephone terminal, making a call without entering Secret Code is impossible.(Only receiving a call is possible).
To make it possible, unlock the setting.

Carry out below procedure.

(Repeat the same procedure for other telephones if Secret Code setup is required for them.)

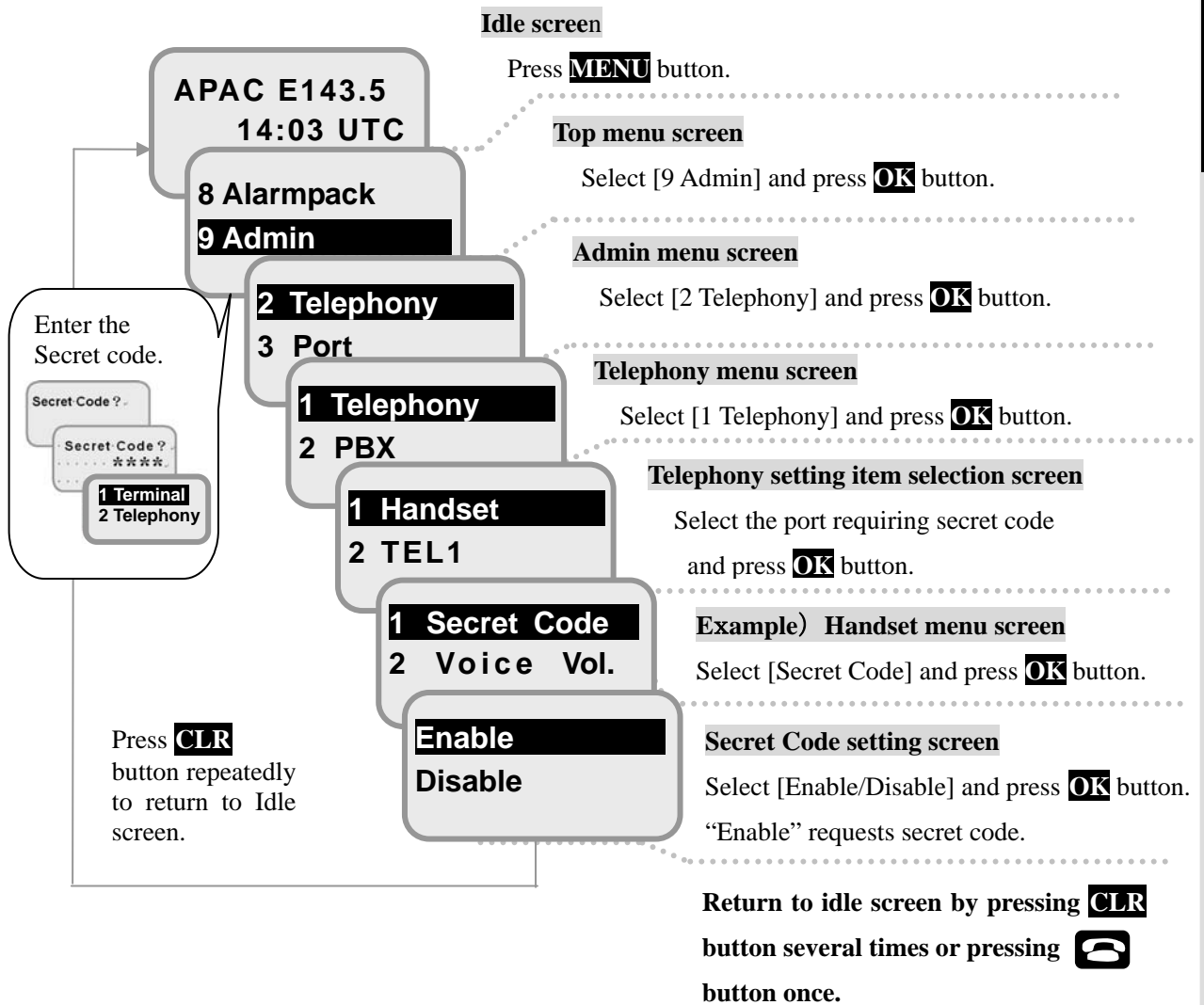

Fig.5.1.8a Flow of setting the Secret Code

5. How to use the telephone/FAX

Secret Code calling

*If you have not set up the Secret Code, open previous page and set it up.

■ Regular Secret Code calling

Secret Code 00 Country Code Area Code Subscriber's number #

Example) Placing a call with secret code 4321, to +81-422-45-9xxx in Japan. → 43210081422459xxx #

■ Secret Code calling with forced service type of Voice service (4kbps Voice)

Secret Code *00 Country Code Area Code Subscriber's number #

■ Secret Code calling with forced service type of FAX (3.1kHz Audio FAX)

Secret Code **00 Country Code Area Code Subscriber's number #

■ Number displaying Secret Code calling with forced service type of FAX (3.1kHz Audio FAX)

Secret Code **1*00 Country Code Area Code Subscriber's number #

■ Non-number displaying Secret Code calling with forced service type of FAX (3.1kHz Audio FAX)

Secret Code **2*00 Country Code Area Code Subscriber's number #

5.1.13 Entry, change and deletion of Phonebook

■ Telephone number entry

Calling procedure with Speed Dial number is explained at [5.1.2 Using Phonebook (Speed Dial)](p5-7). Maximum 200 Speed Dial numbers can be registered though the practically registerable number is defined by your SIM card. The procedures of registration, changing, deleting methods are described below.

Example) Entering a phone number to Speed Dial No.025.

(Name) JOHN (Phone Number) 012345678901234

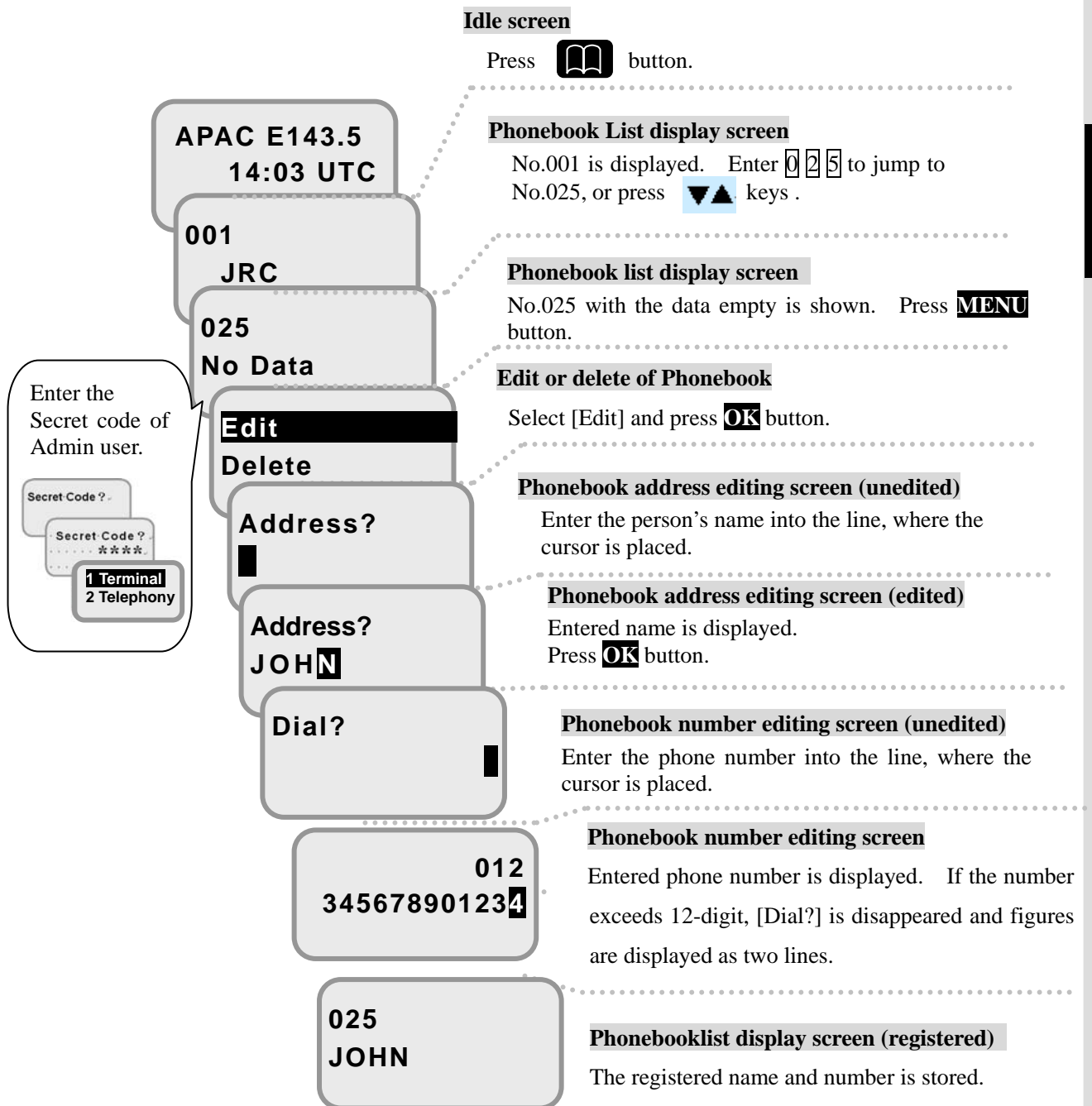

Fig.5.1.13a Flow of telephone number registration to Phonebook

■Deleting data

Example) Deleting Speed Dial No.008, company's name "RRC".

008
RRC

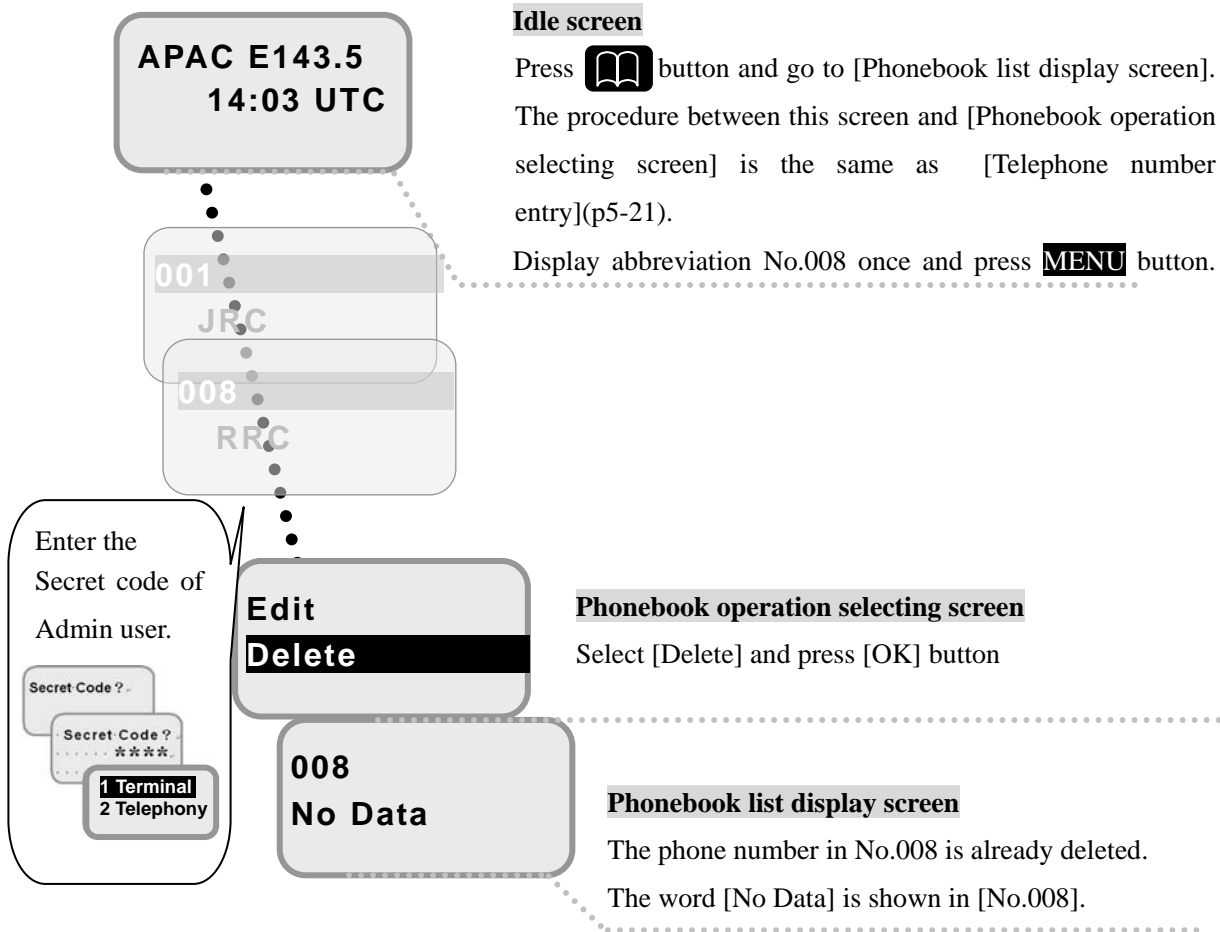

Fig.5.1.13c Flow of deleting data on Phonebook

5. How to use the telephone/FAX

5.1.14 Displaying Call Log

Call Log is displayed in eight service types Voice, Fax, Audio, UDI, RDI, SMS, Standard and Streaming IP for JUE-501 and six service types Voice, Fax, Audio, SMS, Standard and Streaming IP for JUE-251. They are divided into three kinds of screens, Both (outgoing and incoming), Out (outgoing only), and In (incoming only).

1. Voice	Making and receiving a call from/to Handset or terminal telephone connected to TEL or ISDN port
2. Fax	Sending and receiving a facsimile from/to the fax connected to TEL or ISDN port
3. Audio	Using 3.1kHz Audio service on the terminal connected to ISDN or TEL port
4. UDI	Using UDI service on the terminal connected to ISDN port
5. RDI	Using RDI service on the terminal connected to ISDN port
6. SMS	Sending and receiving a SMS from/to the PC connected to Ethernet or Handset port
7. Standard	Using Standard IP service on the PC connected to User LAN port
8. Streaming	Using Streaming IP service on the PC connected to User LAN port

- * [4 UDI] and [5 RDI] menus are not displayed for JUE-251.
- * [Out] and [In] call log displays maximum 100 data on Handset, respectively.
[Both] call log stores latest 100 data of above both directions.
- * Calls are classified into three transmission types, Both (outgoing and incoming transmission), Out (outgoing only), and In (incoming only), except [7. Standard] and [8. Streaming].

To check the contents, follow the instruction shown in next page.

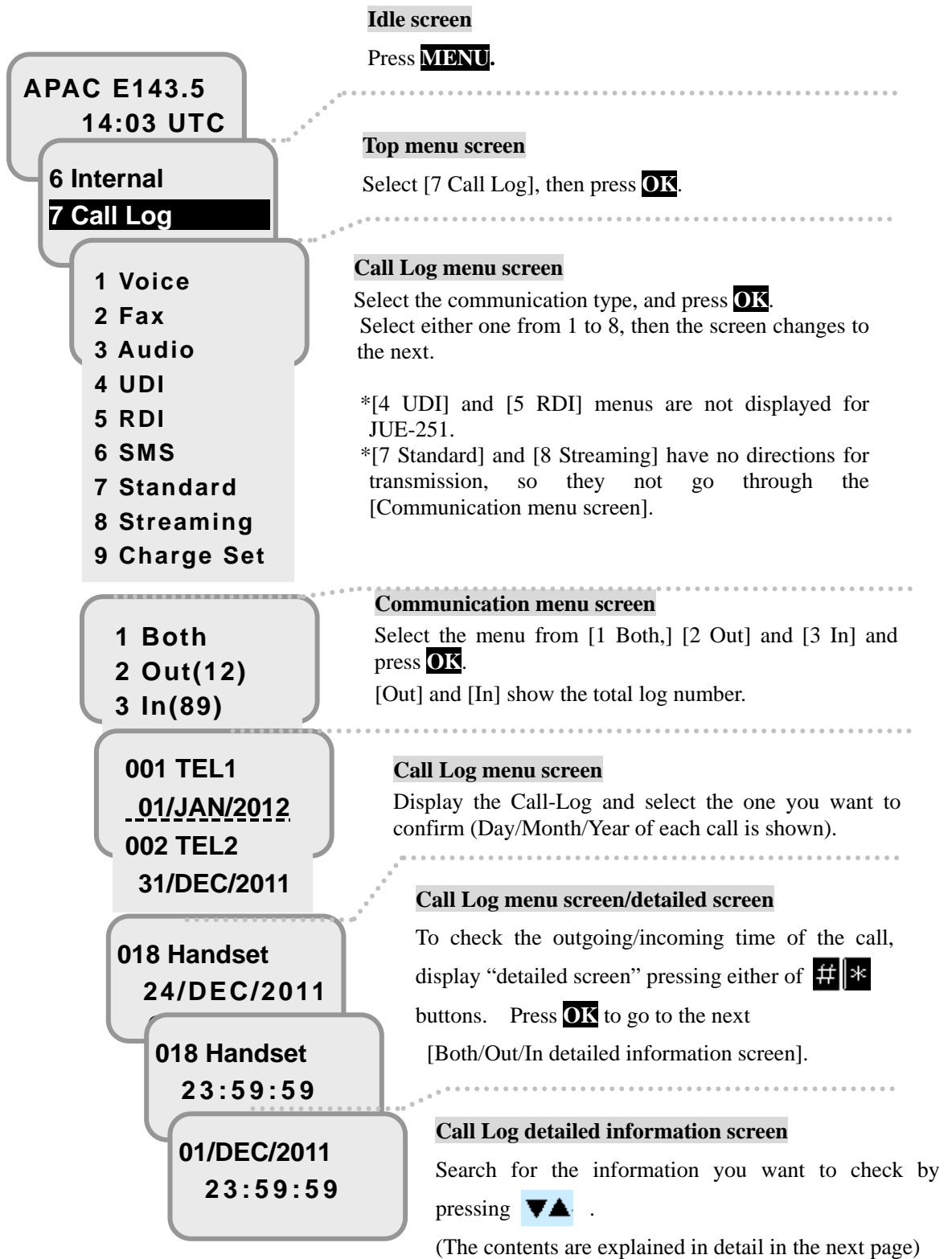

Fig.5.1.14a Flow of displaying Call Log (for JUE-501)

5. How to use the telephone/FAX

Call Log detailed information screen (Voice/Fax/Audio/UDI/RDI services are selected)

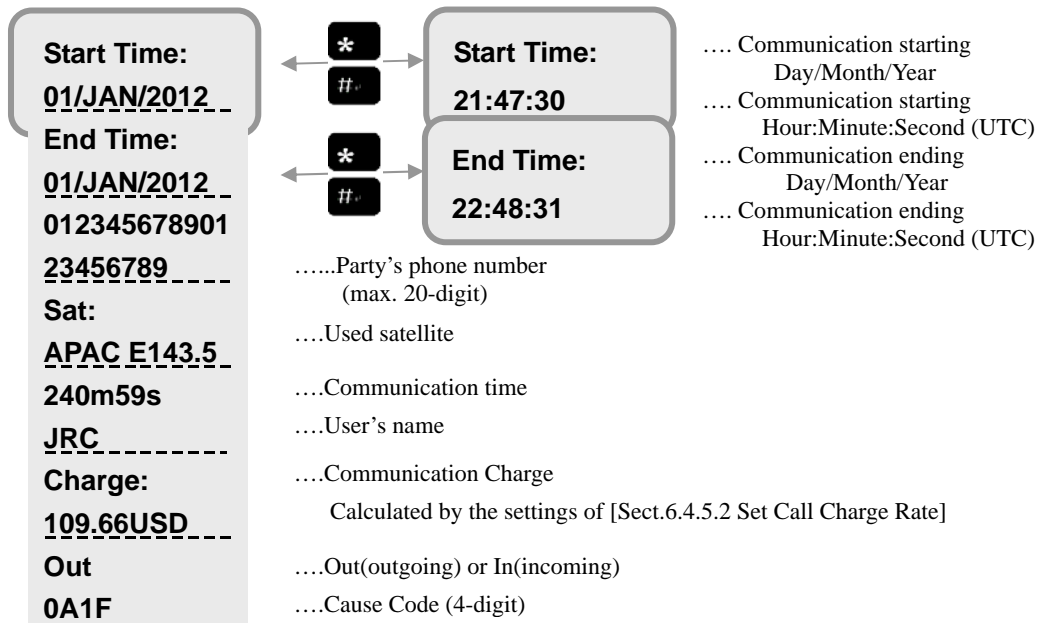

Fig.5.1.14b Call Log detailed information screen (Voice/Fax/Audio/UDI/RDI services are selected)

* User's name is displayed only when Secret Code is required for the transmission.

When Secret Code is not used, it displays [GUEST].

The contents of Call Log detailed information screen are difference depending on the service.

Refer to [7.7 Call Log (Communication history) menu] (p7-26).

5.1.15 Restricting Outgoing Call

Admin user can control originating a call from the terminal connecting to the port. This function can be set by Web interface also (refer to [6.5.2.1 Set up Ports (p6-34)]).

Setting	Function
Enable	Originating a call is permitted.
Allowed Num	Originating a call only to the allowed number (maximum 4) is permitted.
Phonebook	Originating a call only to the number registered in phonebook is permitted.
Disable	Originating a call is prohibited.

If this function is set to Disable, busy tone is heard when you Off-hook the Handset. Dialing is unavailable.

To set the Out (Outgoing) Call “Enable” on Handset port:

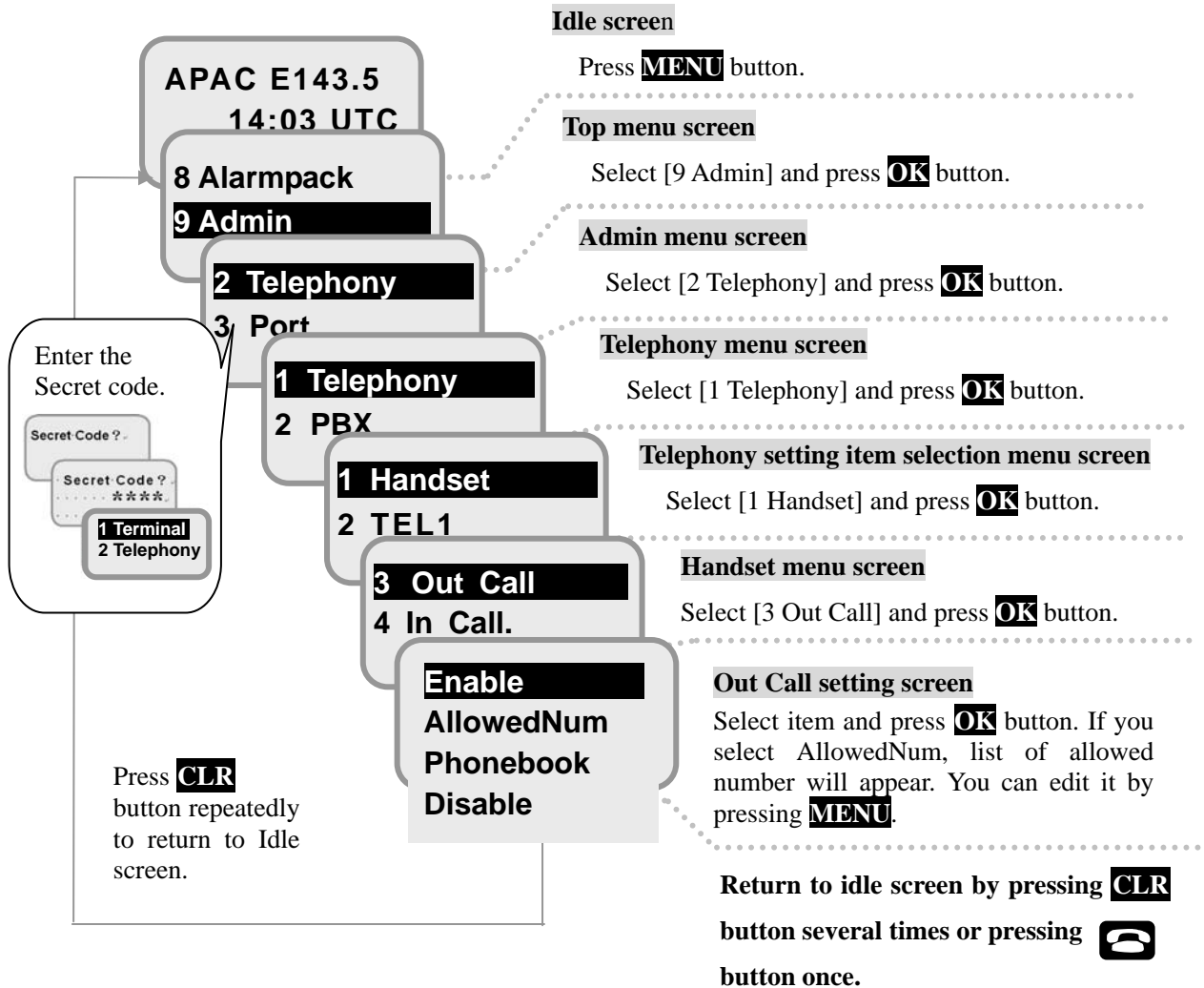

Fig 5.1.15 Out Call setting method

5. How to use the telephone/FAX

5.1.16 Setting Call-Sound for Incoming Call

User can set to ring or not to ring a terminal connected to the main unit, when a call arrived. Also, by selecting the time, user can set the time (seconds) to call up the terminal after the call arriving. This function can be set by Web interface also (refer to [6.5.2.3 Set Telephone Supplementary Service (p6-37)]).

Setting	Function
Enable	Rings when a call is arrived on JUE-501/JUE-251 main unit.
After 5s	Rings after 5 seconds later since a call has arrived on JUE-501/JUE-251 main unit.
After 10s	Rings after 10 seconds later since a call has arrived on JUE-501/JUE-251 main unit.
After 20s	Rings after 20 seconds later a call has arrived on JUE-501/JUE-251 main unit.
Disable	Not sounds

To set the In (Incoming) Call "Enable" on Handset port:

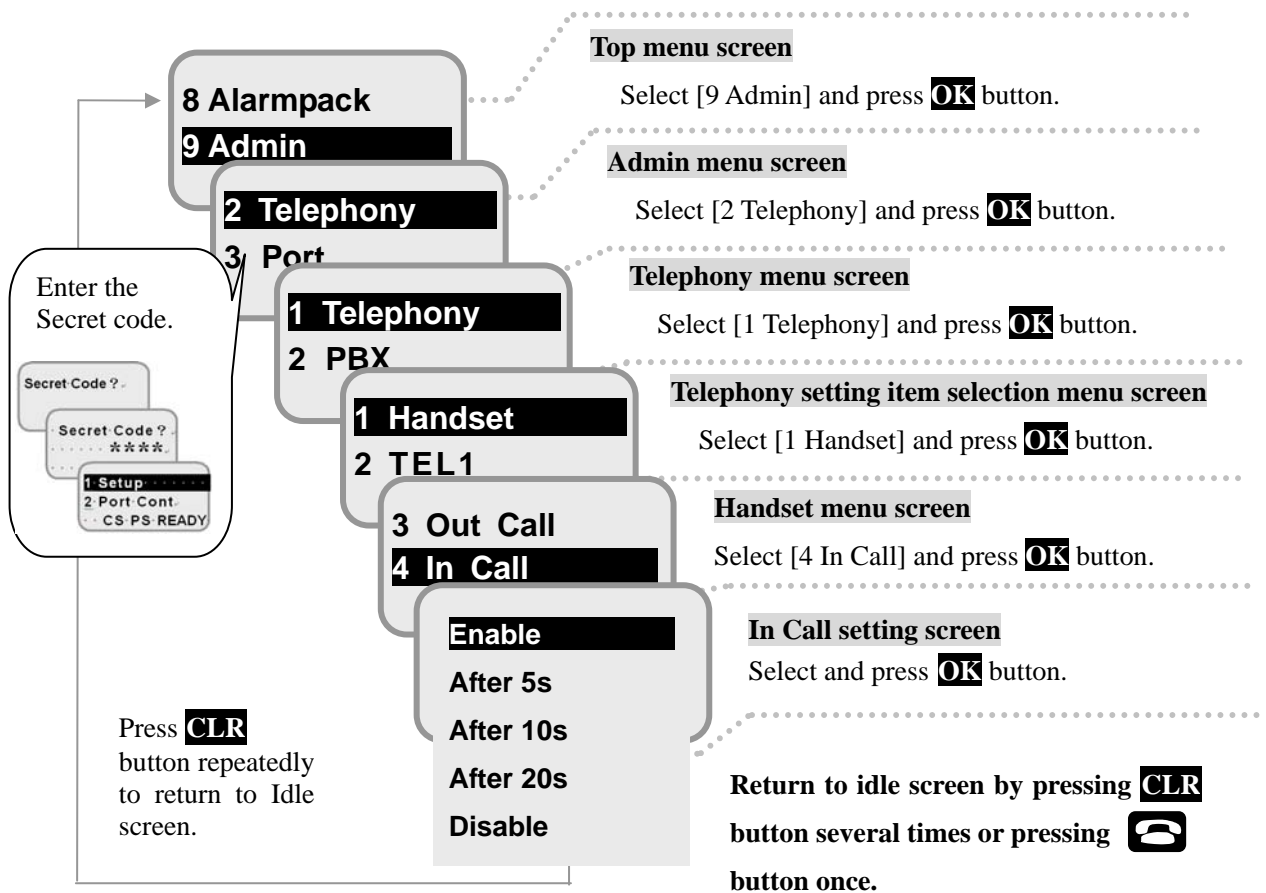

Fig 5.1.16 In Call setting method

5.2 Using telephone/FAX with TEL port

5.2.1 Dial-up procedure

The telephone number dialed last is memorized in MES. Redialing of telephone is simple.

Also, both of the telephone and FAX connected to TEL ports can utilize the abbreviation number of Phonebook. Refer to the procedure below.

Table 5.2.1a. Dial-up procedure of the JUE-501/JUE-251

Dial-up procedure of the JUE-501/JUE-251 (Available from terminal telephone)	
<ul style="list-style-type: none"> ■ Regular calling 	<p style="text-align: center;">00 Country Code Area Code Subscriber's number #</p> <p>Example) Placing a call to +81-422-45-9xxx, in Japan → 0081422459xxx#</p>
<ul style="list-style-type: none"> ■ Speed Dialing 	<p style="text-align: center;">Speed Dialing number (2 digits or 3 digits) * #</p> <p>Example) Calling by a Speed Dialing number 05 → 05*# Calling by a Speed Dial number 083 → 83*# Calling by a Speed Dial number 128 → 128*#</p>
<ul style="list-style-type: none"> ■ Redial calling 	<p style="text-align: center;">*#00 (Last dialed number which is stored in each port is redialed)</p>
<ul style="list-style-type: none"> ■ Secret Code calling 	<p style="text-align: center;">Secret Code 00 Country Code Area Code Subscriber's number #</p> <p>Example) Placing a call with secret code 4321, to +81-422-45-9111 in Japan. → 43210081422459xxx*</p>

5. How to use the telephone/FAX

Dial-up procedure for forced setting of service type

Just adding * or ** on the head of dialing sequence, user can easily set the service type (Voice or FAX) to TEL port, regardless of setup done at [6.5.2.1 Set up Port (p6-34)].

This is temporal setting, and available for only transmission (ship to shore).

Table 5.2.1b. Dial-up procedure of the JUE-501/JUE-251, for forced setting of each service type

Setting Voice service (4kbps Voice) to TEL port	
■ Regular calling	* 00 Country Code Area Code Subscriber's number #
■ Speed Dialing	* Speed Dialing number * #
■ Redial calling	* 00 * #
■ Secret Code calling	Secret Code * 00 Country Code Area Code Subscriber's number #
Setting FAX service (3.1kHz Audio FAX) to TEL port	
■ Regular calling	* * 00 Country Code Area Code Subscriber's number #
■ Speed Dialing	* * Speed Dialing number * #
■ Redial calling	* * 00 * #
■ Secret Code calling	Secret Code * * 00 Country Code Area Code Subscriber's number #

The contents of above-mentioned table are the same as the one of the third page of this chapter, table 5b.

Dial-up procedure for number display and non-display

In this menu, user sets whether notifying or not-notifying their number to the recipient by just adding 1+* or 2+* on the head of dialing sequence.

This is a temporary setting, and available for only transmission.

Table 5.2.1c. Dial-up procedure for number display and non-display

Displaying number	
■ Regular calling	1 * 00 Country Code Area Code Subscriber's number #
■ Speed Dialing	1 * Speed Dialing number * #
■ Redial calling	1 * 00 * #
■ Regular calling with forced service type of Voice (4kbps Voice)	* 1 * 00 Country Code Area Code Subscriber's number #
■ Secret Code calling	Secret Code 1 * 00 Country Code Area Code Subscriber's number #
■ Secret Code calling with forced service type of FAX (3.1kHz Audio FAX)	Secret Code * * 1 * 00 Country Code Area Code Subscriber's number #
Not displaying number	
■ Regular calling	2 * 00 Country Code Area Code Subscriber's number #
■ Speed Dialing	2 * Speed Dialing number * #
■ Redial calling	2 * 00 * #
■ Regular calling with forced service type of Voice (4kbps Voice)	* 2 * 00 Country Code Area Code Subscriber's number #
■ Secret Code calling	Secret Code 2 * 00 Country Code Area Code Subscriber's number #
■ Secret Code calling with forced service type of FAX (3.1kHz Audio FAX)	Secret Code * * 2 * 00 Country Code Area Code Subscriber's number #

The contents of above-mentioned table are the same as the one of the fourth page of this chapter, table 5c.

5. How to use the telephone/FAX

5.2.2 Calling Internal Phone

To make an internal call, press **#** and the extension number listed in table below.

Table 5.2.2 Allocated Extension Number

Device	Allocated number
Handset	000
TEL1~TEL6	001~006
All TEL ports and Handset	099
ISDN (Set PBX-MSN. Refer to p6-40.)	401
All	999

Example) Make a internal call to Handset → **# 000**

5.2.3 Forwarding a call to the other terminals

We have two ways to pass a call to the terminal telephones which connected to BDE. One is **Quick Forwarding** and another is **Talk Forwarding**.

To forward a call to outside call automatically, refer to [6.5.2.3 Set Telephone Supplementary Service (p6-37)] or [7.9.2.3 Suppl. setting (p7-50)].

Quick Forwarding

Quick Forwarding forwards an outside call to local terminals connected to BDE without any talk on internal call.

To use Quick Forwarding, press ****** and the extension number during the communication. After you heard the beep tone, put the receiver back in its cradle.

Talk Forwarding

Talk Forwarding forwards an outside call to local terminals connected to BDE after a talk on internal call.

To use Talk Forwarding, press **0*** and the extension number during the communication. The specified terminal will ring and you can talk with your crew on internal call. Put the receiver back in its cradle after your internal call finished. Then your crew can talk with the outside caller.

Refer to table below for extension numbers of the JUE-501/JUE-251.

Table 5.2.5 Allocated Extension Number

Device	Allocated number
Handset	000
TEL1~TEL6	001~006
All TEL ports and Handset	099
ISDN (Set PBX-MSN. Refer to p6-40.)	401
All	999

Example) Transfer a call to TEL1 with Quick Forwarding.....******+001+[On-hook]

Transfer a call to Handset with Talk Forwarding.....**0***+000

To cancel forwarding mode, press ****+*****.

Forwarding mode will be cancelled and return to [on communication status]

5. How to use the telephone/FAX

5.2.4 Handling Call Waiting

You may hear a call waiting Indication during talking on the phone. The call waiting Indication tone is two beeps every three seconds. To handle call waiting, the phone must have **R** key. **R** key can be replaced by pushing hook button of the phone for short time. Enable / disable call waiting is performed by Web setting (refer to [6.5.2.3 Set Telephone Supplementary Service (p6-37)]).

Follow the procedure below as desired.

Hold the current call, and accept the waiting call.

Press **R 2 #**, during the call waiting indication is ringing.

To exchange the held call for the active call, press **R 2 #**.

To clear the active call and back to the held call, press **R 1 #**.

Clear the current call, and accept the waiting call.

Press **R 1 #**, during the call waiting indication is ringing.

Reject the waiting call.

Press **R 0 #**.

Ignore the waiting call.

Just ignore the waiting call indication (take no action).

These functions are not supported by BDE-APP 1.03.

A new version supporting them is planned to be provided soon.

5.2.5 Holding on the line

To hold a call on, the phone must have **R** key. **R** key can be replaced by pushing hook button of the phone for short time.

Follow the procedure below as desired.

Place a call on hold.

Press **R 2 #**, during the call is active.

Exchange held call for active call.

Press **R 2 #**.

Place the existing call on hold and establish a new call.

Press **R** and dial the second phone number followed by **#**.

Example) Establishing new call to +81422-45-9xxx in Japan → **R 0081422459xxx #**

Clear the active call and back to the held call.

Press **R 1 #**.

Clear the holding call (if no waiting call exists).

Press **R 0 #**.

NOTE

The BGAN system supports only one Call Waiting at the same time.

6. Web Menu System

In this Chapter, the way how to operate or set Web setting menus is explained as described below.

1. Connect Your PC to JUE-501/JUE-251 (Sec. 6.1)
2. Web Screen (Sec. 6.2)
3. Login/Logout (Sec. 6.3)
4. Menus for all users (Sec. 6.4)

Subsection	Content
6.4.1 Dashboard	displays the status of JUE-501/JUE-251
6.4.2 Connect Internet	displays active connection list and makes data connection
6.4.3 SMS Menus	contains New Message/Inbox/Sent/Draft/ Setting
6.4.4 Phonebook	displays and sets phonebook
6.4.5 Call Log Menus	contains Call Log/Call Charge
6.4.6 System Log Menus	contains Alarmpack/Event Log/ADE Monitor

5. Menus for Admin users (Sec. 6.5)

Subsection	Content
6.5.1 Set basic Information	sets basic information of JUE-501/JUE-251
6.5.2 Telephony Menus	contains Telephony/PBX/Supplementary
6.5.3 Port Menus	contains Handset/ISDN/Ethernet/I/O/Option
6.5.4 User Control Menus	contains User Registration/Device Registration/Usage Restriction
6.5.5 Network Menus	contains WAN Profile/Packet Filter/Always Activate/Remote Activate/LAN Group/LAN/Static DHCP/Routing Table/WAN Selector
6.5.6 Disconnect Automatically by time	sets auto disconnect function
6.5.7 Configure SIM	sets SIM configuration
6.5.8 File Export / Import	exports and imports files
6.5.9 Reset to Factory Default	reset to the factory default
6.5.10 Update Software	updates software
6.5.11 Perform Diagnostic Test	performs a diagnostic test

NOTE

In some condition of JUE-501/JUE-251, it may fail to display intended screen. In that case, please click the item once again.

6.1 Connect Your PC to JUE-501/JUE-251

We assume here the Operation System of your PC is Microsoft Windows XP and JUE-501/JUE-251 is running under the initial settings.

Set your PC

1. Open the [Start] menu from the Desktop and click [Control Panel].
 - [Control Panel] window will appear.

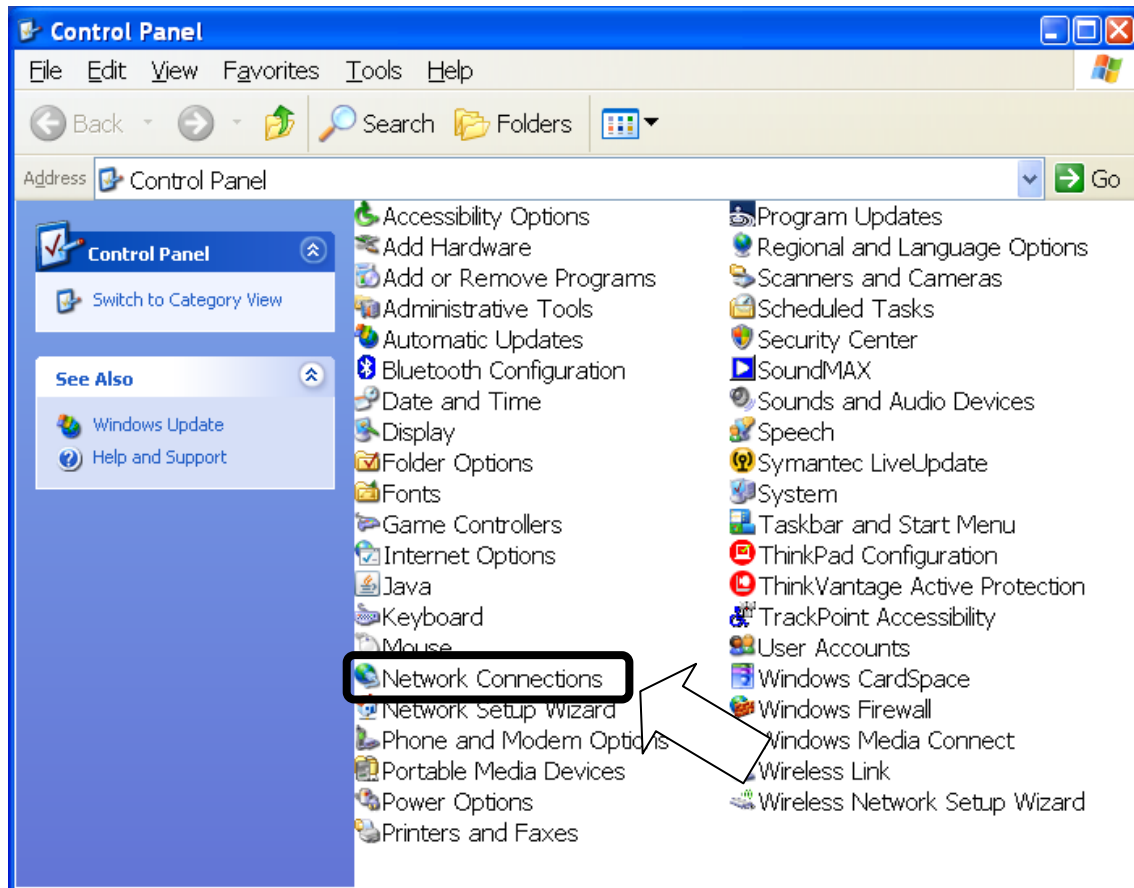

Fig. 6.1a Control Panel window

2. Double-click the icon labeled [Network Connections].
 - [Network Connections] window will be displayed.

3. Select [Local Area Connection] and right-click, then click [Properties] from displayed menu.
 - [Local Area Connection Properties] dialogue box is displayed.
 - Confirm that [General] tab is displayed on the front of the screen.

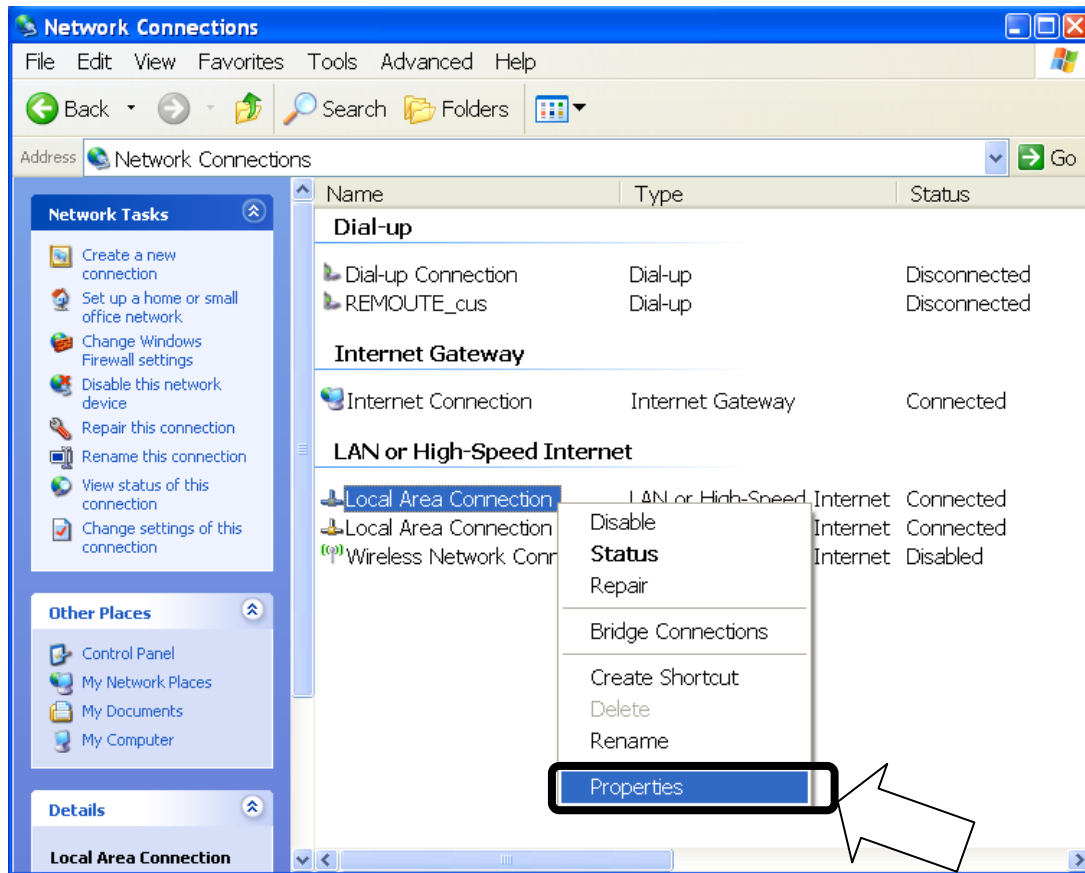

Fig. 6.1b Network Connections window

6. Web Menu System

4. Select [Internet Protocol (TCP/IP)] and click [Properties] button.

- [Internet Protocol (TCP/IP) Properties] dialogue box is displayed.
- Select [Obtain an IP address automatically].

cf. If you want to set your IP address manually, check your JUE-501/JUE-251 IP address.

The initial settings are:

IP address	192.168.128.100
Subnet Mask	255.255.255.0

Then, setting of your PC might be

IP address	192.168.128.101
Subnet Mask	255.255.255.0
Default gateway	192.168.128.100

- Select [Obtain DNS server address automatically].

When you set IP address manually, select [Use the following DNS server address].

Input *192.168.128.100 to the [Preferred DNS server] box and remain blank in the [Alternate DNS server] box.

* We explain here with the assumption of factory default. In practice, enter the IP Address of main unit.

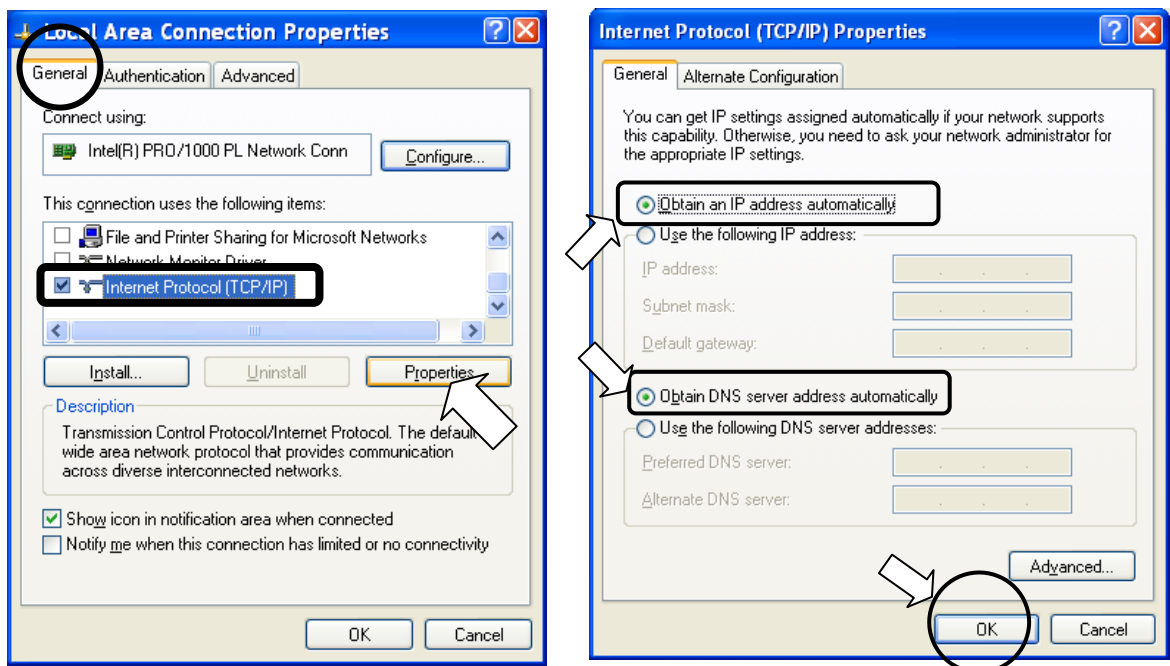

Fig. 6.1c Local Area network properties

5. Click [OK] button.

- Screen is returned to [Local Area Connection Properties] dialogue box.

6. Click [OK] button.

- If message of rebooting is displayed, reboot the PC.

Connect your PC to User LAN port of JUE-501/JUE-251

Connect your PC to User LAN port with Ethernet cable. JUE-501/JUE-251 recognizes the type of Ethernet cable (cross or straight) automatically. A maximum of total 32W PoE (Power over Ethernet) is available on User LAN.

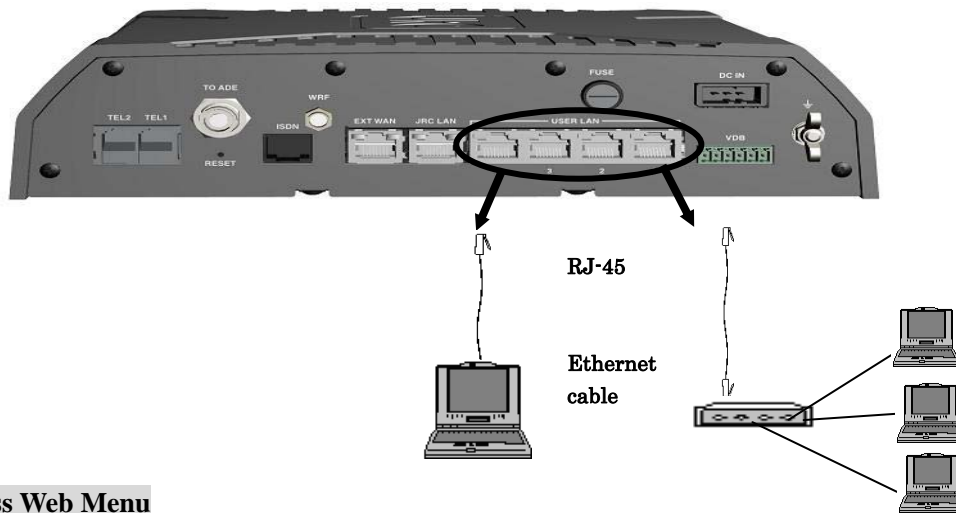

To Access Web Menu

Launch ^{*1} your Web browser ^{*2} and enter [192.168.128.100] ^{*3} to the URL box. Then press [Enter] key.

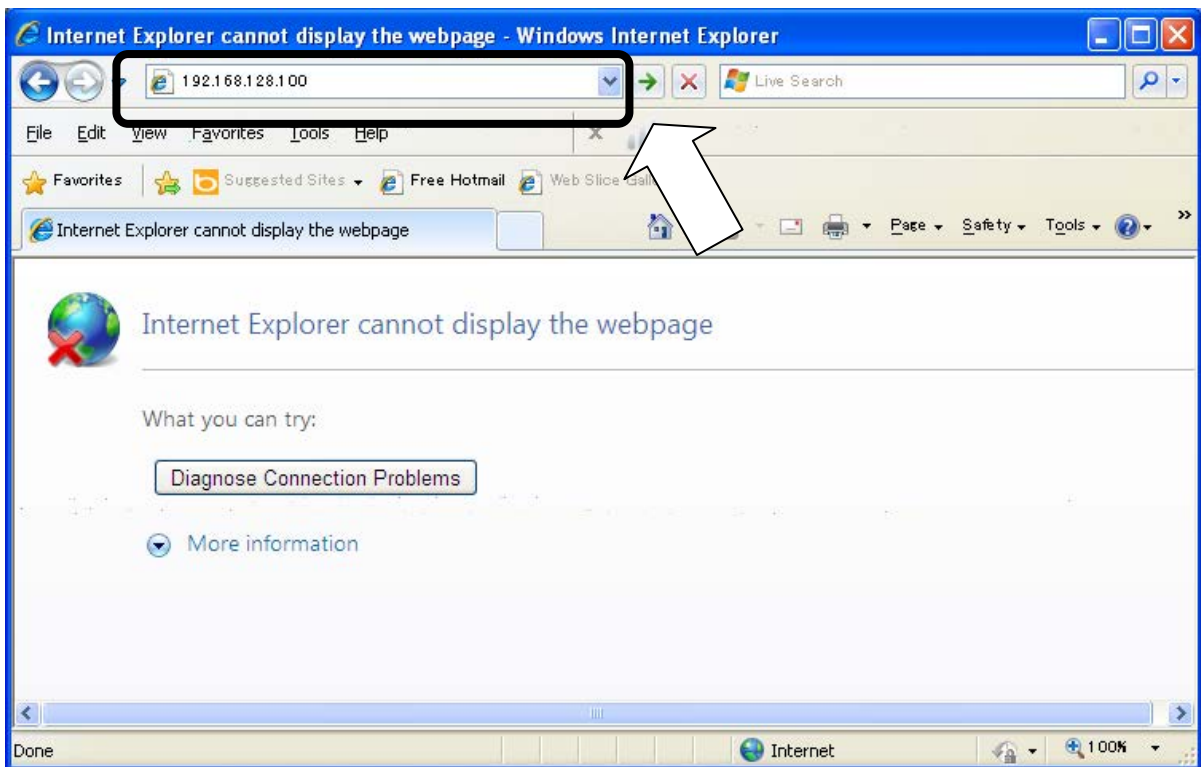

^{*1} Your PC must be in the same network with main unit (refer to [Set your PC], P6-2).

^{*2} While JUE-501 / JUE-251 officially supports Microsoft Internet Explorer7 and Mozilla Firefox3.6, their upper version can be available when they have compatible system.

^{*3} We explain here with the assumption of factory default. In practice, enter http://[main unit IP Address]/ to the URL box of your Web browser.

6.2 Web Screen

Basic Constitution of Web Menu

All screens have constitution mentioned below.

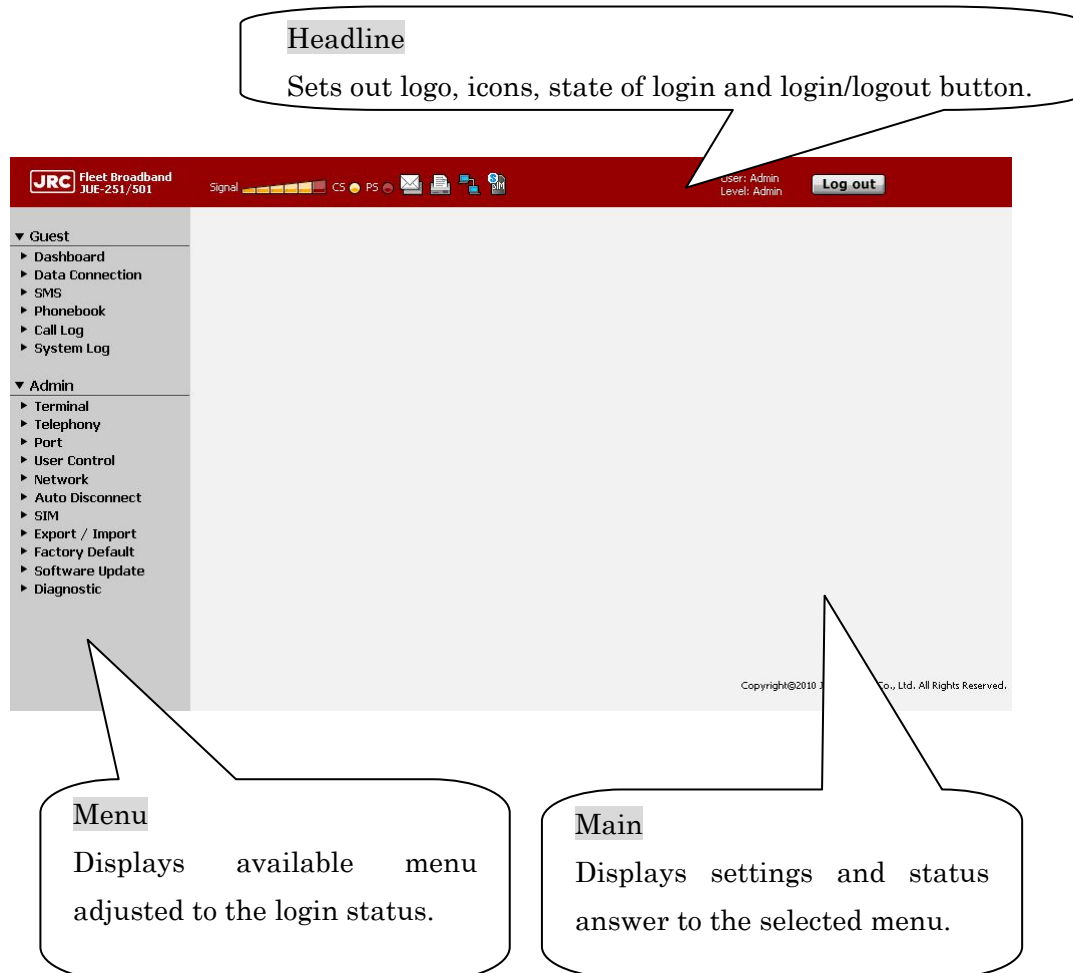













Fig. 6.2 Basic Constitution of Web Screen

Meanings of Icons

In this section, the icons set out in the headline are got together.

Table 6.2 Headline Icons

Icon	Explanation
Signal 	Reception Level Indicator Displays reception level by its number of bar at seven steps. Green color suggests ordinal status and Orange color blocking status. See table 6.5.1b of this manual.
CS 	CS Icon Displays CS connection is in process.
PS 	PS Icon Displays PS connection is in process.
	SMS Icon Displays there are some newly arriving SMS messages.
	SMS Icon (FULL) Displays the memory capacity for SMS on the SIM card is full. To receive or send new SMS message, delete SMS messages on the SIM card.
	FAX Icon (not-available) Displays FAX is out of service. This icon is displayed when satellite elevation angle (EL) value of JUE-251 is less than 20 degrees.
	Remote Access Icon Displays a remote access (a connection established by Remote Activate function [refer to Sec.6.5.5.4 Establish Remote Connection (p6-62)] or a connection established for remote maintenance) is active.
	SIM Card Icon Displays SIM card is set correctly.
	Secondary SIM Card Icon Displays Secondary SIM Card is in use.
	Login button Login to the specific user.
	Logout button Logout any currently logged in user.

6. Web Menu System

Menu

[Menu] lying in the left side of the screen is adjusted to the login status.

With the “Guest menu”, basic operations (PS connection and SMS operation) can be performed as well as the indication of the device status. With the “Admin menu”, device setting (port setting, user controlling, network setting and so on) can be performed.

When an item in the [Menu] is clicked, it displays the item to the [Main] screen.

6.3 Login/Logout

In this section, how to login and logout is explained. **Cookie need to be enabled** in your Web browser. While users can access JUE-501/JUE-251 without logging in, configuring main unit and connecting packet data by granted permissions is available by logging in.

The state of login is shown in the right side of the headline.



Fig. 6.3a Example of Headline panel

User Login

Log in made by user name and their Secret Code. User Login needs that the user is registered (refer to [Sec.6.5.4.1 Register Users], p6-45) in advance. To login by [User Login], click [Login] button lying in the right end of the headline and enter user name and their secret code. Make sure that **Cookie is enabled** in your Web browser. When you logged in, the [Login] button changes into [Logout] button. Click the [Logout] button when you want to logout.

The default Admin user is registered as 01 user with user name “ADMIN” and secret code “0001”.

Device Reorganization

JUE-501/JUE-251 recognizes a terminal automatically with the IP address when it has been registered in advance. This is convenient for the devices which can not handle “user login” like cameras to connect internet. For more information about device registration, see [Sec.6.5.4.2 Register Devices] (p6-47).

Registered devices are recognized automatically (by its IP address). Then User Login/Logout (by their name and secret code) can be made when the user clicks the Login/Logout button.

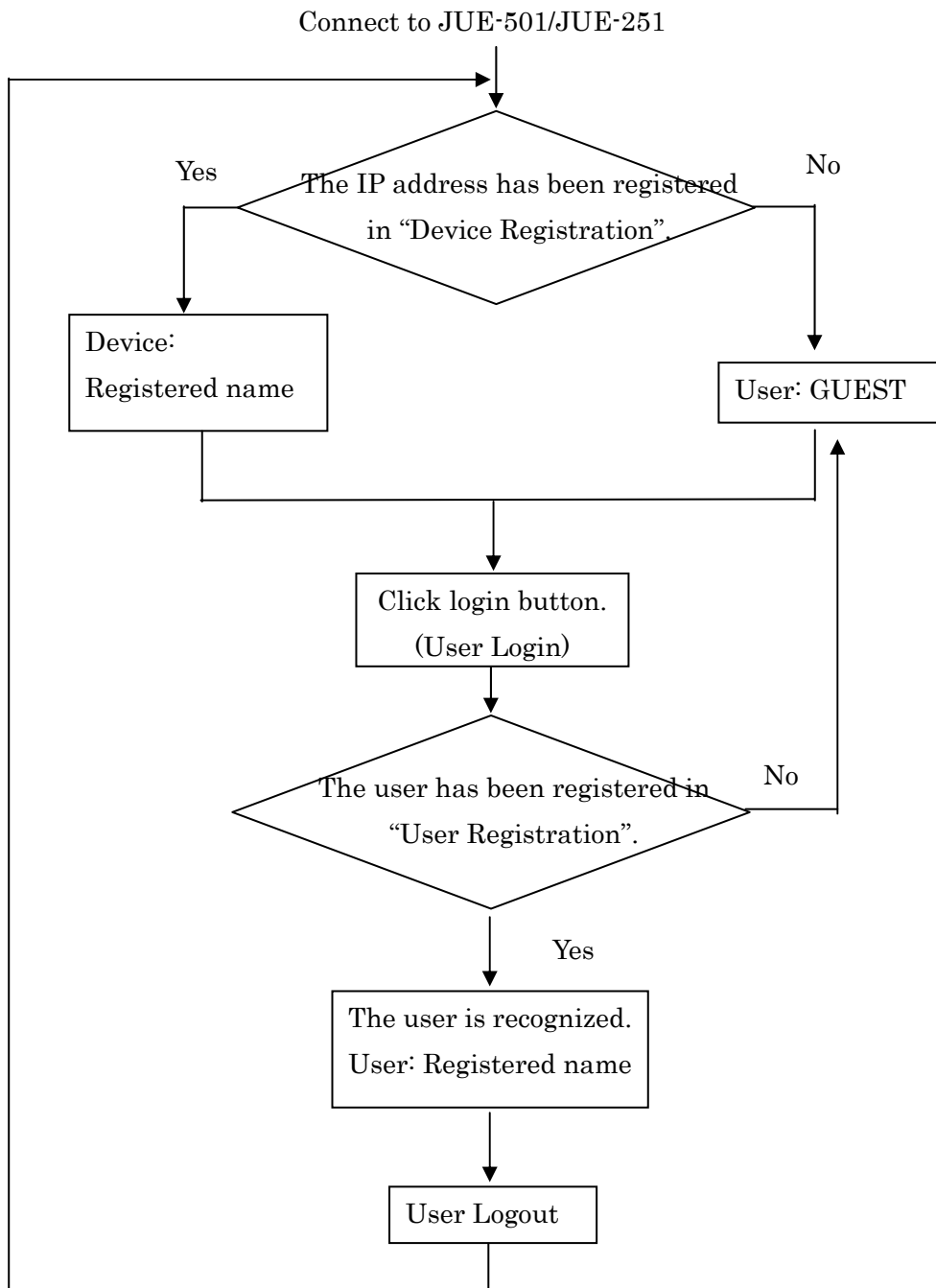

Fig. 6.3 b Flow of login

HINT

To control users refer to [6.5.4 User Control Menu](p6-45).

6.4 Menus for all Users

6.4.1 Dashboard (Dashboard Screen)

To enter the Dashboard screen, select “Dashboard” from the left [menu] panel.

Dashboard screen mainly displays status of JUE-501/JUE-251 and consists of following five parts

1.Information, 2.Quick Connect, 3.Active Session & Calls, 4.Setting, and 5.Display Style.

1. Information part

Displays the status of JUE-501/JUE-251.

Information			
a) Status	CS PS READY	g) Latitude	35° 41' 16" N
b) Time	05:18:52 07/AUG/2012	h) Longitude	139° 34' 16" E
c) Satellite	APAC 143.5° E	i) REC	63
d) Spot Beam No.	9	j) EIRP	0.0
e) Alarm		k) Heading	0.0
f) WAN Selector	FBB	l) Bearing	166.9
		m) Elevation	49.0

Fig. 6.4.1a Dashboard-Information part

Table 6.4.1a Contents of Dashboard-Information

a)	Status	Status of JUE-501/JUE-251	
		CS PS READY	Communication is available (available both CS and PS connection)
		CS READY	Communication is available (available only CS connection)
		PS READY	Communication is available (available only PS connection)
b)	Time	Current time (Displayed in UTC when local time has not been set.)	
c)	Satellite	Current-using satellite name and longitude	
d)	Spot Beam No.	Current-using spot beam Number	
e)	Alarm	Displayed in red text, during TX alarm generation TX ALARM is the function that informs the TX output is turned off due to a failure on the TX system.	
f)	WAN Selector	Current-using WAN access route	
g)	Latitude	Ship's latitude	
h)	Longitude	Ship's longitude	
i)	REC	Current reception level (value-displaying version of antenna icon)	
j)	EIRP	Current transmission level	
k)	Heading	Heading value of the ship (only for GYRO mode)	
l)	Bearing	Current Bearing value (Antenna direction when the bow is set to 0 degree.)	
m)	Elevation	Current Elevation value	

2. Quick Connect part

Connect to the internet quickly and easily via Standard IP connection. These buttons are available only when [Quick Connect] has been enabled for the login user in User Registration [Sec. 6.5.4.1](p6-45) or Device Registration [Sec. 6.5.4.2](p6-47).

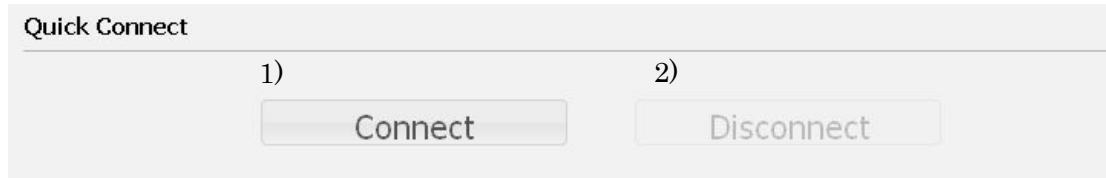

Fig. 6.4.1b Dashboard-Quick Connect part

Table 6.4.1b Contents of Dashboard-Quick Connect

1)	Connect button	Connects to the internet (available only when unconnected)
2)	Disconnect button	Disconnects the internet (available only when connected)

3. Active Session & Calls part

This block shows active sessions and calls.

Active Session & Calls						
1)Type	2) User	3) Time	4) Port			
Voice	Jamie	20m 34s	TEL1			
1)Type	2) User	3)Time/Byte	5)Local IP	6)Global IP	7) APN	
Standard	Stewart	12.34 MB	192.168.128.1	32.48.64.80	bgan.inmarsat.com	
Streaming	Willis	12m 34s	192.168.128.2	33.49.65.81	bgan.inmarsat.com	

Fig. 6.4.1c Dashboard-Active Session & Call part

Table 6.4.1c Contents of Dashboard-Active Session & Call

1)	Type	Service Type	
		Voice	4 kbps AMBE service
		Audio	3.1 kHz Audio service
		Standard	Standard IP service
		Streaming	Streaming IP service
2)	User	Connecting user. User name for CS communication is recognized by Secret Code. If Secret Code is not used on the CS communication, the user name will be GUEST.	
3)	Time/Byte	Communication time In Standard communications, data size is displayed. In Standard communications, logs are saved every 10 M Byte.	
4)	Port	Using port	
5)	Local IP	1by1 NAT: Connecting local IP IP Masquerade: Connecting local network address PPPoE: PPPoE bridge mode	
6)	Global IP	Using global IP	
7)	APN	Access Point Name	

4. Setting part

This block sets Heading value, Satellite selection method, or clears TX Alarm. The state of TX Alarm can be confirmed by Dashboard-Information part.

* Although there is nothing wrong with JUE-501/JUE-251, selecting satellite makes some noise on ADE.

The screenshot shows a 'Setting' section with three items:

- 1) Heading: An input field with a 'Set' button to its right.
- 2) Satellite: A dropdown menu currently showing 'Auto' with a 'Set' button to its right.
- 3) TX Alarm: A 'TX Alarm Clear' button.

Fig. 6.4.1d Dashboard-Setting part**Table 6.4.1d Contents of Dashboard-Setting**

1)	Heading	Input Heading value. (This term is displayed only when Gyro is selected for Tracking mode)
2)	Satellite	Set the satellite to be used. When you select Auto, JUE-501/JUE-251 automatically selects the most suitable satellite.
3)	TX Alarm	Click [TX Alarm Clear] button when TX Alarm is displayed in Alarm column (table 6.4.1a (e)) of Information part, and the TX output limitation

		will be cleared.
--	--	------------------

TX ALARM

TX ALARM is displayed (Fig. 6.4.1a e)) when a failure is occurred on the transmission system.

Release TX ALARM because transmission output function is turned off by compulsion when this alarm is generated.

Step1: Press [TX Alarm Clear] to release the TX ALARM.

Step2: Check the ALARM column (Fig. 6.4.1a e)) is turned to empty. If TX ALARM is not disappeared, execute Step1 again.

If TX ALARM generated frequently, contact the dealer you purchased JUE-501/JUE-251 from.

5. Display Style part

This part sets display style of Web screen.



Fig. 6.4.1e Dashboard-Display Style part

Table 6.4.1e Contents of Dashboard-Display Style

1)	Color Style	Select style from following five styles, JRC Red, Marine Pale Blue, BGAN Navy Blue, Gray Scale, and Earth.
----	-------------	---

6.4.2 Connect Internet (Data Connection Screen)

To enter the Data Connection screen, select “Data Connection” from the left [menu] panel.

On this screen, user can easily connect the internet within their permission. This screen varies by users (permissions) set in User Registration or Device Registration.

For more information about User Registration and Device Registration, refer to [Sec. 6.5.4.1 Register Users](p6-45) and [Sec.6.5.4.2 Register Devices](p6-47).

Data Connection screen consists of two parts, “Connection List” and “Setting”.

1. Connection List

The list displays the information of PS connections. The list contains connection status (* means the connection is active), user, local IP address, Global IP address, service type, communication rate and using APN. Disconnect buttons are available only when [Multi Connect] has been enabled for the login user in User Registration [Sec. 6.5.4.1](p6-45) or Device Registration [Sec. 6.5.4.2](p6-47).

Connection List							
Active	User	Local IP	Global IP	Type	Rate	APN	Disconnect
*	Admin	192.168.128.11	111.222.100.200	Standard		bgan.inmarsat.com	<input type="button" value="Disconnect"/>
	Barry	192.168.128.12	111.222.100.201	Streaming	256k/128k	bgan.inmarsat.com	<input type="button" value="Disconnect"/>

Fig. 6.4.2a Data Connection-Connection List part

2. Setting

Setting for connecting to the internet. The setting displayed here is the same with the profile which has been assigned to the user on User Registration [Sec. 6.5.4.1](p6-45) or Device Registration [Sec. 6.5.4.2](p6-47). User can edit the setting only when their assigned profile permits them to edit it.

Fig. 6.4.2b Data Connection-Setting part

Table 6.4.2 Contents of Data Connection-Setting part

1)	Connection Status	Status of connection
2)	Profile	Assigned profile “Manual” can be selected only when the user is permitted to edit the profile.
3)	Connection Type	Available service type defined by assigned profile
4)	Desire Rate	Desire Rate for the connection (Only for the streaming service)
5)	Minimum Rate	Minimum Rate for the connection (Only for the streaming service) Connection will be cut automatically when the communication rate falls below this rate.
6)	Local IP	Local IP address for the connection. * Other IP is available only when [Multi Connect] has been enabled for the login user in User Registration [Sec. 6.5.4.1](p6-45) or Device Registration [Sec. 6.5.4.2](p6-47).
7)	APN	Access Name Point
8)	APN User/Password	User name and Password for APN. The password will be hidden by ● when it entered.
9)	Global IP	Select Dynamic or Static for Global IP address used for this connection. Input of Global IP address is required only when Static is selected.
10)	Connect/Disconnect	Connect/Disconnect the connection
11)	Connection Type	Connection type for the secondary service
12)	Desire Rate	Desire Rate for the secondary connection (Only for the streaming service)
13)	Minimum Rate	Minimum Rate for the secondary service (Only for the streaming service) Secondary service will be cut automatically when the communication rate falls below this rate
14)	Connect/Disconnect	Connect/Disconnect the secondary connection

6.4.3 SMS Menu

SMS menu is on the left [menu] panel.

In this menu, reference of each message stored in SIM, sending SMS and setting of SMS can be executed.

SMS icon  appears on the Headline of the Web page when new message arrived to the main unit. Check the message out on the Inbox screen.

SMS Menu contains following screens.

- New Message Screen (Sec. 6.4.3.1 SMS New Message)
- Inbox Screen (Sec. 6.4.3.2 SMS Inbox)
- Sent Screen (Sec. 6.4.3.3 SMS Sent box)
- Draft Screen (Sec. 6.4.3.4 SMS Draft box)
- Setting Screen (Sec. 6.4.3.5 SMS Setting)

NOTE

SMS icon (FULL)  appears on the Headline of the Web page when the memory capacity for SMS on the SIM card is full. Delete unnecessary messages to receive or send new message. How to delete individual message is described in [Sec. 6.4.3.2-4] and how to delete all message is described in [Sec. 6.4.3.5].

To check message capacity, refer to [Sec. 6.4.3.5].

6.4.3.1 SMS New Message (New Message Screen)

To enter the New Message screen, open “SMS” menu on the left [menu] panel and select “New Message”.

On New Message Screen, you can write and send new SMS message.

Fig. 6.4.3.1 New Message Screen

Table 6.4.3.1 Contents of New Message Screen

Display		Contents
1)	To	Destination for the message
2)	Refer to Phonebook	Refers to Phonebook instead of entering the telephone No. into 1) “To” textbox
3)	Text	Displays contents of message
4)	Send	Sends message
5)	Save	Saves message into Draft box
6)	--/---	(Entered character number) / (Maximum capacity of character number in SMS)

How to send a New Message

Step1: Enter the destination directly to “To” text box or select the name of destination from Phonebook in “Refer to Phonebook” box.

Step2: Write a message in “Text” box. SMS message can contain maximum 160 characters.

Step3: Click “Send” button, and the message is sent.

The sent message is saved in “Sent” screen. Click “Save” button to save the message into “Draft” box.

NOTE

In some condition of JUE-501/JUE-251, it may fail to send message. In that case, the message is saved into “Draft” box.

6. Web Menu System

6.4.3.2 SMS Inbox (Inbox Screen)

To enter the Inbox screen, open “SMS” menu on the left [menu] panel and select “Inbox”.

On this screen, user can check received message. Select a data from the Message List, and whole the message will be displayed on “Detail (the upper part of the screen)”.

To make some action (Reply/Forward/Delete) to the displayed message, click buttons below the Text box.

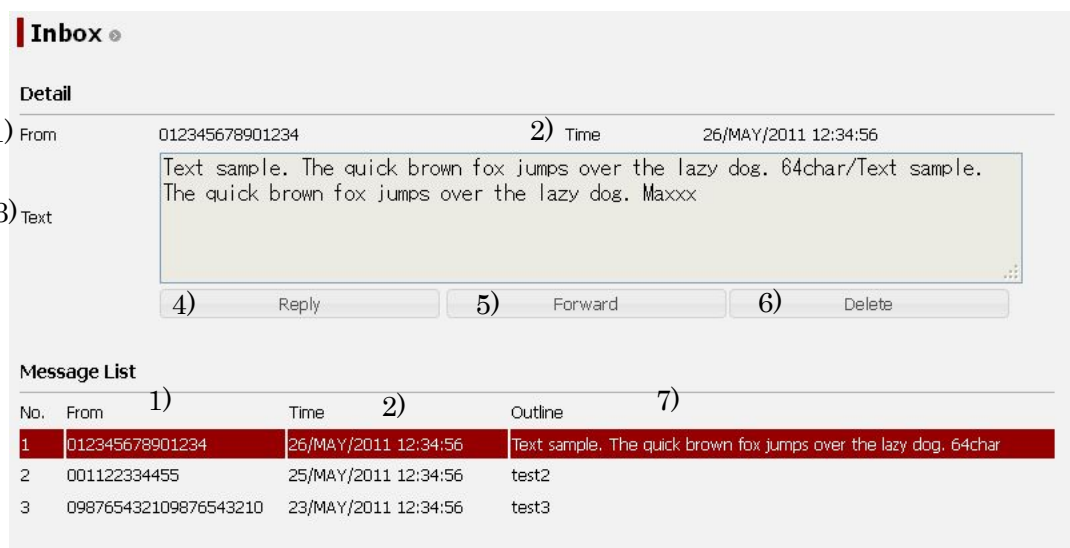

Fig. 6.4.3.2 Inbox Screen

Table 6.4.3.2 Contents of Inbox Screen

Display		Contents
1)	From	Sender
2)	Time	Reception date and time (UTC)
3)	Text	Message contents
4)	Reply	New message screen is displayed as the replay screen to the sender.
5)	Forward	New message screen is displayed as the forwarding screen.
6)	Delete	Deletes displayed message
7)	Outline	Head part of the message

6.4.3.3 SMS Sent box (Sent Screen)

To enter the Sent screen, open “SMS” menu on the left [menu] panel and select “Sent”.

On this screen, user can check sent message. Select a data from the Message List, and whole the message will be displayed on “Detail (the upper part of the screen)”.

To make some action (Resend/Forward/Delete) to the displayed message, click buttons below the Text box.



Fig. 6.4.3.3 Sent Screen

Table 6.4.3.3 Contents of Sent Screen

Display		Contents
1)	To	Destination for the message
2)	Text	Message contents
3)	Resend	New message screen is displayed for resending the message.
4)	Forward	New message screen is displayed as the forwarding screen.
5)	Delete	Deletes displayed message
6)	Outline	Head part of the message

*Sent messages are not necessarily stored in order of their transmitted time.

6.4.3.4 SMS Draft box (Draft Screen)

To enter the Draft screen, open “SMS” menu on the left [menu] panel and select “Draft”.

On this screen, user can check saved message in Draft box. Select a data from the Message List, and whole the message will be displayed on “Detail (the upper part of the screen)”.

To make some action (Edit/Forward/Delete) to the displayed message, click buttons below the Text box.

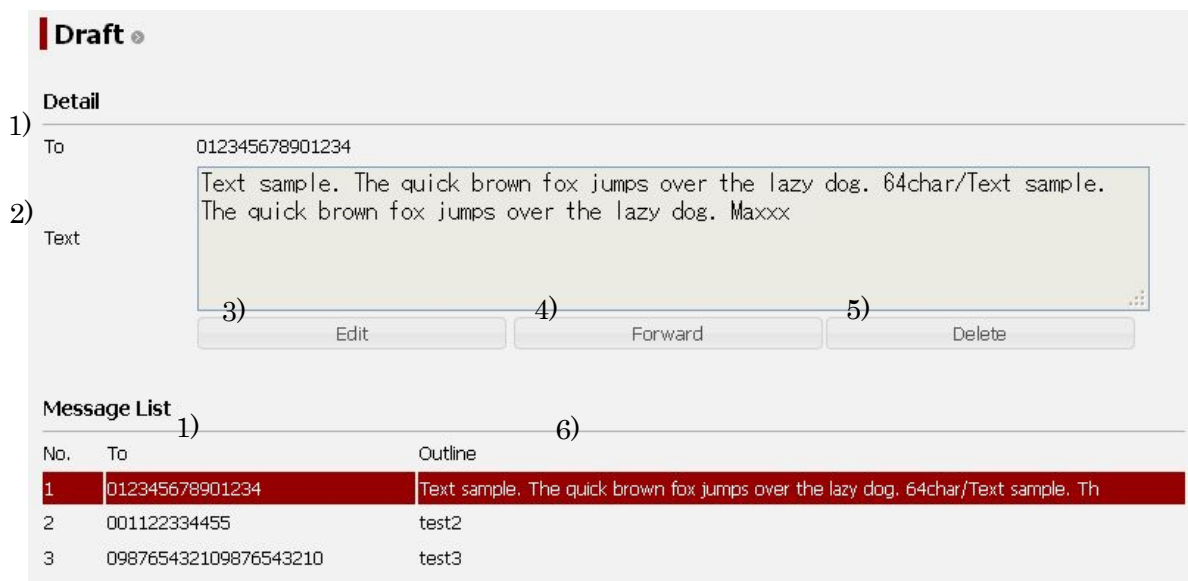

Fig. 6.4.3.4 Draft Screen

Table 6.4.3.4 Contents of Draft Screen

Display		Contents
1)	To	Destination for the message
2)	Text	Message contents
3)	Edit	New message screen is displayed for editing To and Text box and sending the message. *After this operation, when Send is clicked on the editing screen, this Draft message will be deleted. And when Save is clicked in that screen, this Draft message will be overwritten.
4)	Forward	New message screen is displayed as the forwarding screen.
5)	Delete	Deletes displayed message
6)	Outline	Head part of the message

*Draft messages are not necessarily stored in order of their saved time.

6.4.3.5 SMS Setting (Setting Screen)

To enter the Setting screen, open “SMS” menu on the left [menu] panel and select “Setting”.

On this screen, user can check message capacity and delete all messages.

Also user can set the details of SMS Service.

Fig. 6.4.3.5 SMS Setting Screen

Table 6.4.3.5 Contents of SMS Setting

Display		Contents
1)	Message Capacity	The number of the message which can be saved, and the preservation number of the present message are displayed.
2)	Delete All Message	Deletes all messages
3)	Service Center Address	Telephone No. of service center
4)	Validity	Storage validity term counted from the SMS is received by the Service Center.
5)	Service Class	Service class of sending SMS sets the behavior of the message after it is sent to recipient's terminal. No Class: Not specified Class 0: Displays only (not stored) Class 1: Requests to store in recipient phone memory Class 2: Requests to store in recipient SIM memory Class 3: Uses recipient's default mode
6)	Status Report	Delivery confirmation (Status Report) is available or not
7)	Send Character Code	Character code (GSM7/Unicode) of SMS Limit on the number of characters changes into 70 when Unicode was selected.
8)	SET	Registers setting contents

6.4.4 Phonebook (Phonebook Screen)

To enter the Phonebook screen, select “Phonebook” from the left [menu] panel.

On this screen, Phonebook stored in SIM card can be displayed. Phonebook can contain a maximum of 254 combinations of Name and Phone number. (The practical number which can be registered is based on SIM card.) Users with Admin level can set, edit and delete phonebook easily on this screen.

The screenshot shows a web interface titled "Phonebook". At the top left, there is a "File" button labeled "a)". Below this is a table with three rows. The columns are labeled "ID", "Name" (labeled "b)"), "Number" (labeled "c)"), and "SET/DEL" (labeled "d)"). The first row has ID "01", Name "Mitaka", and Number "0081422177". The second row has ID "02", Name "Tokyo", and Number "00813177". The third row has ID "03" and empty input fields. To the right of each row are "Set" and "Del" buttons.

Fig. 6.4.4 Phonebook Screen

Table 6.4.4 Contents of Phonebook Screen

a)	File button	Displays the contents of Phonebook in CSV text format. *If this function is executed by multiple PCs simultaneously, the file may be damaged. In this case, obtain the file again. *Follow the PC manual to save the data.
b)	Name	Party's name (maximum 10 characters)
c)	Number	Party's telephone number (maximum 20 numbers)
d)	Set/Del button	Set button registers entered items (Party's name and number). Del button deletes entered items (Party's name and number)

Procedure of registration

Step 1: Input a party's name into the b) Name column of preferred ID.

Step 2: Input a party's telephone number into the c) Number column of the same row.

Step 3: Click d)[Set] button to register the items in the row.

Procedure of deletion

Step 1: Click d)[Del] button and the items in the row are deleted.

6.4.5 Call Log Menus

Call Log menu is on the left [menu] panel.

In this menu, user can display/clear the Call Log and set Call Charge to calculate communication charge.

Call Log Menu contains following screens.

- Call Log Screen (Sec. 6.4.5.1 Check Call Log)
- Call Charge Screen (Sec. 6.4.5.2 Set Call Charge Rate)

6.4.5.1 Check Call Log (Call Log Screen)

To enter the Call Log screen, open “Call Log” menu on the left [menu] panel and select “Call Log”.

A maximum of 2000 Call Logs are stored in this page. When the stored logs exceed 2000 affairs, it deletes the oldest one.

The screenshot shows the 'Call Log' interface. At the top left, there is a dropdown menu labeled 'Output' (1) and a 'Delete' button (2). Below these are navigation buttons: '<< Newer' (3), '1' (2), and 'Older >>' (3). The main area is a table with columns: No., Start Time (4), End Time (5), Conn. Type (6), Term./IP (7), Dir. (8), Called No./APN (9), User (10), Time/Byte (11), Charge (12), Sat (13), and Code (14). The table contains two rows of data.

No.	Start Time	End Time	Conn. Type	Term./IP	Dir.	Called No./APN	User	Time/Byte	Charge	Sat	Code
1	08:33:41 10/SEP/2012	08:34:42 10/SEP/2012	Standard	192.168.128.180	---	lgan.inmarsat.com	JRC	17208	0.00 USD	E 143.5	0024
2	08:33:37 10/SEP/2012	08:33:09 10/SEP/2012	Standard	192.168.128.180	---	lgan.inmarsat.com	JRC	5652	0.00 USD	E 143.5	0024

Fig. 6.4.5.1. Call Log Screen
Table 6.4.5.1 Contents of Call Log Screen

1)	Output	Displays call logs in the CSV text format. *If this function is executed by multiple PCs simultaneously, the file may be damaged. In this case, obtain the file again. * Follow the PC manual to save the data.
2)	Delete	Deletes selected Call Log.
3)	Display button	Displays newer / older logs.
4)	Start Time	Communication starting time (UTC)
5)	End Time	Communication ending time (UTC)
6)	Conn. Type	Connection type (Voice/Audio/Standard/Streaming/SMS/UDI/RDI) *UDI/RDI is not available for JUE-251.
7)	Term.	Used port
8)	Dir.	Communicated direction (Out(Outgoing)/In(Incoming)) *This column is blank for Standard/Streaming service.
9)	Called No./APN	Party's address (if it is acquired) (In the Standard/Streaming service, APN is displayed).

6. Web Menu System

10)	User	For CS connection, the user is recognized by secret code. (Only when it was inputted.) For PS connection, the user is recognized by the login status.
11)	Time/Byte	Communication time In Standard communications, data size is displayed. In Standard communications, logs are saved every 10 M Byte.
12)	Charge	Estimated charge for the communication calculated by “Call Charge” function.
13)	Sat	Number of using satellite
14)	Code	Cause code

Sorting call log

Step1: Click one of the column titles (No./ Start Time/ End Time/ Conn. Type/ Term/ Dir./ Called No./APN/ User/ Time/Byte/ Charge/ Sat/ Code) to sort the call log.

The sort function is applied only to the displayed log.

(If the sort function would not work, refer to [Appendix L.11.When the call log sort function is not working] (pL-12).)

Filtering call log

The column with a pull-down menu can display the filtered log by the selected word. The filter is applied to all the logs.

Step1: Select the service type to delete from the pull-down menu.

Outputting procedure

Step1: Click Output button

The Call Log is Displayed in the CSV text format on Web browser.

*If this function is executed by multiple PCs simultaneously, the file may be damaged. In this case, obtain the file again.

* Follow the PC manual to save the data.

Clearing procedure

Step1: Select the service type to delete from the pull-down menu.

Step2: Click Delete button.

Call Logs are deleted.

6.4.5.2 Set Call Charge Rate (Call Charge Screen)

To enter the Call Charge screen, open “Call Log” menu on the left [menu] panel and select “Call Charge”.

JUE-501/JUE-251 calculates the communication charge automatically from the list of “Rate for Unit” when it is filed by user. The calculated charge is displayed in Call Log.

NOTE

- * This calculation is only a rough estimation based on user input.
- * JRC does not take any responsibility for the correctness of the estimated charge.
- * Settings for UDI, RDI and 256k Streaming are not displayed for JUE-251 because FB250 system doesn't support these services.
- * Only Admin users can change these settings.

The screenshot shows the 'Call Charge' configuration screen. It is divided into two main sections: 'Currency Select' and 'Rate for Unit'.

Currency Select: A dropdown menu is set to 'USD' (labeled 'Step 1'). To its right is a 'Set' button (labeled 'Step 2').

Rate for Unit: A table lists various connection types with their respective charge rates. A 'Set' button (labeled 'Step 4') is located at the bottom right of this section.

Connection Type	Charge	Unit
Voice	2.15	USD per min.
Audio	9.99	USD per min.
UDI	9.99	USD per min.
RDI	9.99	USD per min.
SMS	0.88	USD per mail.
Standard	7.65	USD per MB.
8k Streaming	4.75	USD per min.
16k Streaming	4.75	USD per min.
32k Streaming	4.75	USD per min.
64k Streaming	9.80	USD per min.
128k Streaming	14.98	USD per min.
256k Streaming	24.58	USD per min.

Fig. 6.4.5.2 Call Charge Screen

Procedure of setting Call Charge

- Step 1: Select the Currency from the pull down menu. The menu contains USD, EUR and JPY.
- Step 2: Click the Set button located to the right side of the Currency.
- Step 3: Enter the charge for at a rate per unit time (minute), size (Mbyte) and mail.
- Step 4: Register the settings by clicking Set button below.

6.4.6 System Log Menus

System Log menu is on the left [menu] panel.

In this menu, user can display/clear the status and logs of JUE-501/JUE-251.

System Log Menu contains following screens.

- Alarmpack Screen (Sec. 6.4.6.1 Check Alarmpack)
- Event Log Screen (Sec. 6.4.6.2 Check Event Log)
- Distress Log Screen (Sec. 6.4.6.3 Check Distress Log)
- ADE Monitor Screen (Sec. 6.4.6.4 Check ADE)

6.4.6.1 Check Alarmpack (Alarmpack Screen)

To enter the Alarmpack screen, open “System Log” menu on the left [menu] panel and select “Alarmpack”.

On this screen, current alarm information and alarm history (maximum 50 cases) can be displayed.

Alarmpack

Serial No. 1)IMEI No. 2) JRC No. 3) MAC1 4) MAC2
 3588770 [REDACTED] GV [REDACTED] 00:00:27 [REDACTED] 00:00:27 [REDACTED]

Maintenance No. 5)ADE-Boot 6)ADE-Main 7)BDE-Boot 8) BDE-Safe 9) BDE-Main 10) BDE-App 11) Service Class
 0.1 70.22 00.17 00.25 00.24 00.82 9

12) File

13) 14) 15) 16)
 Expand All Expand ADE Expand BDE Expand MDM

17) 19) 20) All 21) ADE 22) BDE 23) MDM

ADE-ALM:None EIRP:0.0 ADETmp:+0.0 HPATmp:+49.0 SAT AZ:173.4 SAT EL:48.4 BR:192.3
 EL:47.0 Cross EL:0.0 RSSI-1:0 RSSI-2:165 Search-Sts:2 Track Mode:Auto
 ADE-GPS:3D Fix GPSHD:---- PLL LockDet:ON Globalbeam:10994
 WRF Filter:Narrow WRF Port:Disable WRF Moni:96
 Rol-Ave:0.0 Pit-Ave:0.5 VibX-Ave:0.0 VibY-Ave:0.0 VibZ-Ave:0.8
 Rol-Max:0.0 Pit-Max:0.6 VibX-Max:0.1 VibY-Max:0.0 VibZ-Max:0.9

BDE-ALM:None APAC E143.5 SpotNo.:9 REC:57 HD:0.0 BDE-Sts:CS PS READY
 35° 41' 16" N GPS:built-in GPS-Sts:3D Fix GPS-Time:06:37:14 02/AUG/2012
 139° 34' 16" E ExtGPS:OFF ExtGPS Data:None
 GYRO:Auto NSKDIPSW:00 CableLoss:12.9 CalibErr:0 UpdateErr:0
 RX Mode:T1Q ATT:6 IMSI: [REDACTED]
 BZ:0000 BTN:0000 LAN:010100 Tick:0x00F96541

MDM-ALM:None C/No:57.00 RxChIdx:17820 RxBri:1 Rk Offset:0
 BDE Temp:51 HALAcqSts:3

18) 1 00:01:33 --/--/---- 20) All 21) ADE 22) BDE 23) MDM
 2 00:01:33 --/--/---- 20) All 21) ADE 22) BDE 23) MDM

Fig. 6.4.6.1a Alarmpack Screen

Table 6.4.6.1a Contents of Alarmpack Screen

Serial No.		
1)	IMEI No.	International Mobile Equipment Identity number (15 digits)
2)	JRC No.	manufacturer's serial number (7digits)
3)	MAC 1	MAC address for EXT WAN Ethernet Port.
4)	MAC 2	MAC address for User LAN Ethernet Port and JRC LAN Ethernet Port.
Maintenance No.		
5)	ADE-Boot	ADE Boot maintenance number
6)	ADE-Main	ADE maintenance number
7)	BDE-Boot	BDE Boot maintenance number
8)	BDE-Safe	BDE Safe mode maintenance number
9)	BDE-Main	BDE maintenance number
10)	BDE-App	BDE Application maintenance number
11)	Service Class	Inmarsat Class number 8 is for FBB500 system and 9 is for FB250 system.
Buttons		
12)	File	Displays Alarmpack in the CSV text format. *If this function is executed by multiple PCs simultaneously, the file may be damaged. In this case, obtain the file again. * Follow the PC manual to save the data.
13)	Expand (Shrink) All	Displays (closes) Alarmpack all
14)	Expand (Shrink) ADE	Displays (closes) Alarmpack of ADE part for all the log
15)	Expand (Shrink) BDE	Displays (closes) Alarmpack of BDE part for all the log
16)	Expand (Shrink) MDM	Displays (closes) Alarmpack of MDM part for all the log
17)	Current	Current information
18)	n	Logged information (a maximum of 50 logs)
19)	Time	Logging time (00 : 00 : 00 DD/MMM/YYYY) (UTC)
20)	All	Displays Alarmpack all for the selected log
21)	ADE	Displays Alarmpack of ADE part for the selected log
22)	BDE	Displays Alarmpack of BDE part for the selected log
23)	MDM	Displays Alarmpack of MDM part for selected the log

Each Alarm information has three parts—ADE (Above Deck Equipment) part, BDE (Below Deck Equipment) part and MDM (MoDeM) part.

The details are described below.

6. Web Menu System

1. ADE part

ADE-ALM:None	EIRP:0.0	ADETmp:+0.0	HPATmp:+49.0	SAT AZ:173.4	SAT EL:48.4	BR:192.3
EL:47.0	Cross EL:0.0	RSSI-1:0	RSSI-2:165	Search-Sts:2	Track Mode:Auto	
ADE-GPS:3D Fix		GPSHD:----	PLL LockDet:ON		Globalbeam:10994	
WRF Filter:Narrow		WRF Port:Disable		WRF Moni:96		
Rol-Ave:0.0	Pit-Ave:0.5	VibX-Ave:0.0	VibY-Ave:0.0	VibZ-Ave:0.8		
Rol-Max:0.0	Pit-Max:0.6	VibX-Max:-0.1	VibY-Max:0.0	VibZ-Max:0.9		

Fig. 6.4.6.1b Alarmpack ADE part
Table 6.4.6.1b Contents of Alarmpack ADE part

Line	Display	Contents	Displayed style
1	ADE-ALM:	Existence of ADE alarm	None or objective part
	EIRP:	Transmission status (EIRP value)	0.0~22.0
	ADETmp:	ADE temperature	+0.0 (fixed to 0.0 for JUE-501/251)
	HPATmp:	HPA temperature	-125~125
	SAT AZ:	Satellite AZ	0.0~359.9
	SAT EL:	Satellite EL	0.0~90.0
	BR:	Antenna bearing	0.0~359.0
2	EL:	Antenna EL	-25.0~120.0
	Cross EL:	Antenna XEL	-30.0~30.0
	RSSI-1:	RSSI-1 value	0 (fixed to 0 for JUE-501/251)
	RSSI-2:	RSSI-2 value	0~255
	Search-Sts:	Satellite search status	0~5
	Track Mode:	Tracking Mode	Auto/GpsHD/Sensor/Unknown
3	ADE-GPS:	ADE GPS fix status	Cold Start / Unfix / 2D Fix / 3D Fix
	GPSHD:	ADE GPS Heading	0.0 ~ 359.9
	PLL LockDet:	PLL lock detect	ON/OFF
	GlobalBeam:	Global Beam channel	0, 3200~19600
4	WRF Filter	Using filter	Narrow / Wide
	WRF Port	Use or non-use of WRF port	Enable / Disable / Auto
	WRF Moni	WRF Monitor	0~254
5	Rol-Ave:	Average value of Rolling for last 6 min	-40.0~+40.0
	Pit-Ave:	Average value of Pitching for last 6 min	-40.0~+40.0
	VibX-Ave:	Average value of X vibration for last 6 min (unit: G)	-6.0~+6.0
	VibY-Ave:	Average value of Y vibration for last 6 min (unit: G)	-6.0~+6.0

	VibZ-Ave:	Average value of Z vibration for last 6 min (unit: G)	-6.0~+6.0
6	Rol-Max:	Maximum value of Rolling for last 6 min	-40.0~+40.0
	Pit-Max:	Maximum value of Pitching for last 6 min	-40.0~+40.0
	VibX-Max:	Maximum value of X vibration for last 6 min (unit: G)	-6.0~+6.0
	VibY-Max:	Maximum value of Y vibration for last 6 min (unit: G)	-6.0~+6.0
	VibZ-Max:	Maximum value of Z vibration for last 6 min (unit: G)	-6.0~+6.0

2. BDE part

BDE-ALM:None	APAC E143.5	SpotNo.:9	REC:57	HD:0.0	BDE-Sts:CS PS READY
35° 41' 16" N	GPS:builtin	GPS-Sts:3D Fix		GPS-Time:06:37:14 02/AUG/2012	
139° 34' 16" E	ExtGPS:OFF	ExtGPS Data:None			
GYRO:Auto	NSKDIPSW:00	CableLoss:12.9	CalibErr:0	UpdateErr:0	
RX Mode:T1Q	ATT:6	IMS1:			
BZ:0000	BTN:0000	LAN:010100	Tick:0x00F96541		

Fig. 6.4.6.1c Alarmpack BDE part

Table 6.4.6.1c Contents of Alarmpack BDE part

Line	Display	Contents	Displayed style
1	BDE-ALM:	Existence of BDE alarm	None or objective part
	Name [E,W] ddd.d	Longitude of used satellite	Ex.) APEC E 143.5
	SpotNo.:	Used spot beam number	0~255
	REC:	Reception level	0~70
	HD:	Heading value	0.0~359.9
	BDE-Sts:	BDE status	Ex) CS PS READY
2	ddd° mm ' ss" [N,S]	Latitude	Ex.) 12° 34'56" N
	GPS:	Using GPS	builtin / Ext / Test
	GPS-Sts:	GPS fix status	Cold Start / Unfix / 2D Fix / 3D Fix
	GPS-Time:	GPS UTC	hh:mm:ss dd/MMM/yyyy
3	ddd° mm ' ss" [E,W]	Longitude	Ex.) 123° 45'06" E
	ExtGPS:	External GPS	OFF/ON
	ExtGPS Data:	Receiving GPS sentence	None/ GGA/ ZDA
4	GYRO:	GYRO type (if it is used)	Auto/SYNC/STEP/LAN/ NMEA(4.8k)/ NMEA(38.4k)

6. Web Menu System

	NSKDIPSW:	NSK Unit Dip-SW	XX (00 ~ FF)
	CableLoss:	ADE-BDE Cable loss	0.0~50.0
	CalibErr:	Calibration Error Code	0~255
	UpdateErr:	Updating result	0 (fixed to 0 for JUE-501/251)
5	RX Mode:	Receiving Channel type	T025Q / T1Q / T1X / T45X
	ATT:	BDE attenuator value	0~255
	IMSI:	IMSI value stored in SIM card	123456789012345
6	BZ:	Buzzer Connection status (0:Not connect, 1:Connect)	nnnn
	BTN:	Button Connection status (0:Not connect, 1:Connect)	nnnn
	LAN:	Ethernet Link status (0:Not connect, 1:Connect)	nnnnnn
	Tick:	The timer since system boot	0xnxxxxxxxx

3. MDM part

MDM-ALM:None	C/No:57.00	RxChIdx:17820	RxBrr:1	RX Offset:0
BDE Temp:51	HALAcqSts:3			

Table 6.4.6.1d Contents of Alarmpack MDM part

Fig. 6.4.6.1d Alarmpack MDM part

Line	Display	Contents	Displayed style
1	MDM-ALM:	Existence of Modem alarm	None or objective part
	C/No:	Carrier / Noise ratio	40.0~67.0
	RxChIdx:	Receiving channel index	0, 6400~39280
	RxBrr:	Receiving Bearer	0~3
	RxOffset:	Receiving frequency offset	0 or 1
2	BDE Temp:	BDE Temperature	-125~+125
	HALAcqSts:	HAL Acquisition Status	0~6

6.4.6.2 Check Event Log (Event Log Screen)

To enter the Event Log screen, open “System Log” menu on the left [menu] panel and select “Event Log”.

Latest 1000 events are stored and displayed on this screen. User can display event logs in CSV text format by clicking File button.



Fig. 6.4.6.2 Event Log Screen

Table 6.4.6.2 Contents of Event Log Screen

Display		Contents	
1	File	Displays event logs in CSV text format *If this function is executed by multiple PCs simultaneously, the file may be damaged. In this case, obtain the file again. * Follow the PC manual to save the data.	
2	Date/Time	Logging time (00 : 00 : 00 DD/MMM/YYYY) (UTC)	
3	Event	Boot Start	Turning on the main unit
		Power Off	Turning off the main unit
		REG End	Registering for the satellite
		DEREG End	Deregistering from the satellite
		Search Start	Starting satellite search
		Search End	Ending satellite search
		COMM Start	Starting CS or PS communication
		COMM End	Ending CS or PS communication
4	Result	Success	The event was succeeded.
		Failure	The event was failed or alarm was detected
5	Para1	Parameter1	
6	Para2	Parameter2	

6. Web Menu System

6.4.6.3 Check ADE (ADE Monitor Screen)

To enter the ADE Monitor screen, open “System Log” menu on the left [menu] panel and select “ADE Monitor”.

On this screen, user can monitor the status of ADE. A maximum of 100 ADE logs can be checked on Web browser and a maximum of 7200 ADE logs can be contained in an output file.

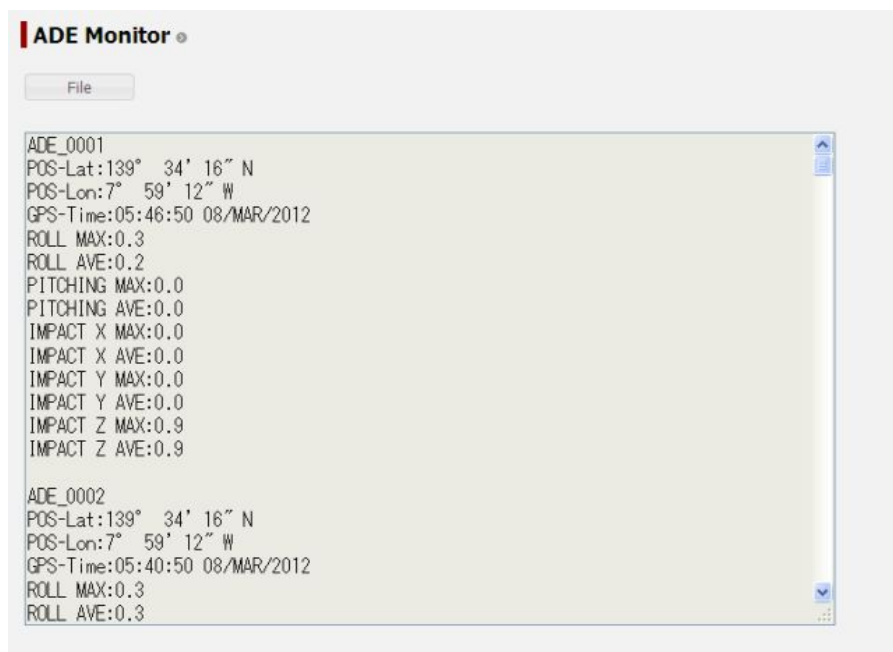

Fig. 6.4.6.4 ADE Monitor Screen

The MAX value and AVE value of ROLL, PITCHING and IMPACT(Vibration) is calculated on the last 6 minutes.

File button displays the contents of ADE Monitor in text format.

*If this function is executed by multiple PCs simultaneously, the file may be damaged. In this case, obtain the file again.

* Follow the PC manual to save the data.

6.5 Menus for Admin Users

6.5.1 Set Basic Information (Terminal Screen)

To enter the Terminal screen, select “Terminal” from the left [menu] panel.

On this screen, the basic data of JUE-501/251 can be set.

Also the blockage areas up to six can be registered to indicate the antenna of JUE-501/JUE251 is being hidden from satellite by an obstruction like ship’s mast or funnel.

Fig. 6.5.1a Terminal Screen

Table. 6.5.1a Contents of Terminal-Setting

Display		Contents
1)	Delivery Date	Operation starting date of JUE-501/JUE-251 Delivery date does not only record the day when the JUE-501/JUE-251 was installed and communication commenced, but it helps to determine the guarantee term etc. Accurate setting is recommended.
2)	Local Time	Time differences between UTC (Universal Time Coordinated) and Local time Select [+] when Local time is faster than UTC, and [-] when it is slower.
3)	Tracking	Tracking method of JUE-501/JUE-251 Select the tracking system from Auto or Gyro. When Gyro is selected, Gyro type is required. Select Gyro type from Sync/Step, NMEA(4.8k), NMEA(38.4k) or LAN. System reboot is required to apply this setting.
4)	GPS Input	Input method of external GPS Select one from Disable (use only built-in GPS), NMEA(4.8k), NMEA(38.4k) or LAN. System reboot is required to apply this setting.

6. Web Menu System

5)	VDR Output	Output method to VDR for sending Alarmpack of JUE-501/JUE-251 Select Disable or LAN. System reboot is required to apply this setting.
6)	WRF	Setting for WRF (Wide-band Radio Frequency) interface. The WRF interface is needed for a navigation system to receive the satellite signal directly. “Enable” uses wide band filter. “Disable” uses narrow band filter and prevents interference of any other radio waves. ”Auto” changes the using filter automatically.
7)	Panel LED	Setting for ON/OFF of the LEDs on the front panel of main unit
8)	Ethernet LED	Setting for ON/OFF of the Ethernet LEDs on the back panel of main unit If “Ethernet LED” is set to “OFF”, the Ethernet LED lamps will remain turned off even when some devices are connected to the LAN ports.
9)	SET	Registers the setting contents

Table. 6.5.1b Contents of Terminal-Blocking Indication

Display		Contents
10)	Enable/Disable	Use or non-use of the Blockage Area
11)	Upper limit EL	Upper limit elevation for the blockage area (Range: 1 to 90)
12)	Lower limit EL	Lower limit elevation for the blockage area (Range: 1 to 90)
13)	Left border BR	Bearer value for Left border of the blockage area (Range: 0 to 359)
14)	Right border BR	Bearer value for Right border of the blockage area (Range: 0 to 359)
15)	SET	Registers the setting contents

6.5.2 Telephony Menu

Telephony menu is on the left [menu] panel.

In this menu, user can set up telephony.

Telephony Menu contains following screens.

- Telephony Screen (Sec. 6.5.2.1 Set up Ports)
- PBX Screen (Sec. 6.5.2.2 Set Auto Answering the Telephone)
- Supplementary Screen (Sec. 6.5.2.3 Set Telephone Supplementary Service)

6.5.2.1 Set up Ports (Telephony Screen)

To enter the Telephony screen, open “Telephony” menu on the left [menu] panel and select “Telephony”.

User can set Outgoing/Incoming service type, operation limit, voice volume, limitation for outgoing call and call up time for each port (Handset/ TEL1~6/ ISDN).

Telephony

Telephony

1) Incoming Type 2) Outgoing Type 3) Secret Code 4) Voice Volume 5) Outgoing Call 6) Incoming Call 7) Allowed Number

Port	Incoming Type	Voice Volume	Outgoing Call	Incoming Call	Allowed Number	Set
Handset	Voice	Normal	Enable	Enable		Set
TEL1	Voice/Audio	Normal	Enable	Enable		Set
TEL2	Voice/Fax	Normal	Enable	Enable		Set
TEL3	Voice/Fax	Normal	Enable	Enable		Set
TEL4	Voice/Fax	Normal	Enable	Enable		Set
TEL5	Voice/Fax	Normal	Enable	Enable		Set
TEL6	Voice/Fax	Normal	Enable	Enable		Set
ISDN	Voice/Fax		Enable	Enable		Set

Fig. 6.5.2.1a Terminal Screen

Table. 6.5.2.1a Contents of Terminal-Setting

Display	Contents
1) Port	Setting Port
2) Outgoing/Incoming Type	Outgoing/Incoming type Each pull down menu contains available type for the port. “Voice” sets type to 4k AMBE service. “Fax” sets type to Fax. “Audio” sets type to 3.1 kHz Audio service. “Voice/Fax” sets type to 4k AMBE service and Fax. “Voice/Audio” sets type to 4k AMBE service and 3.1 kHz Audio service.
3) Secret Code	Operation limit “Enable” requires secret code to operate terminal connected to the port. “Disable” doesn’t require secret code so that anyone can operate terminal connected to the port.
4) Voice Volume	Reception volume Normal or High
5) Outgoing Call	Limitation of originating a call from the port “Disable” denies all outgoing call. “Allowed Number” permits making a call only to the allowed phone numbers. The allowed number list contains a maximum of four phone numbers. It also permits making a call to a phone number which begins with the listed number. (Setting 0081 permits making a call to 0081xxx.) “Phonebook” permits numbers registered in phonebook. “Enable” sets no limitation.
6) Incoming Call	Call up time after a call arrives to the main unit “Enable” rings when a call arrives on main unit. “After Xs” rings after X seconds later since a call has arrived on main unit. “Disable” rings no sound.
7) SET	Registers the setting contents

6. Web Menu System

6.5.2.2 Set Auto Answering the Telephone (PBX Screen)

To enter the PBX screen, open “Telephony” menu on the left [menu] panel and select “PBX”.

In this menu, user can set up auto answer. When auto answer is enabled, a fixed message (Please dial 3 digits extension number.) is reproduced automatically. The main unit waits for input from the caller for set time. If no input is recognized, the call will be forwarded to the default destination. The extension number of JUE-501/JUE-251 is designed as Table 6.5.2.2a.

Table. 6.5.2.2a Extension Number JUE-501/JUE-251

Device	Extension Number
Handset	000
TEL1~TEL6	001~006
ALL TEL ports and Handset	099
ISDN	401
All	999

The screenshot shows the 'PBX' configuration page with the 'Auto Answer' section. It includes five numbered callouts: 1) Control (Disable), 2) Incoming Type (Voice), 3) Default Forwarding (000), 4) Limit Time (15 sec), and 5) a 'Set' button.

Fig. 6.5.2.2a PBX Screen

Table. 6.5.2.2b Contents of PBX-Auto Answer

Display		Contents
1)	Control	Validation of Auto Answer
2)	Incoming Type	Incoming service type (Voice/Audio) for adapting auto answer
3)	Extension Number	Default destination for forwarding a call when no input had been recognized for “Limit Time”. *The call will not be forwarded when the terminal doesn’t accept the service type specified at “2) Incoming Type”. Check your Telephony settings (Sec.6.5.2.1).
4)	Limit Time	Waiting time for input from caller
5)	SET	Registers the setting contents

NOTE

- * Auto Answer function is not available when the land telephone can not handle DTMF.
- * Auto Answer function answers the call even when the receiver is absent, and thus the communication charge will be incurred.
- * JRC is indemnified for any communication fee troubles using this function except as outlined in the product warranty and by limitation of law.

6.5.2.3 Set Telephone Supplementary Service (Supplementary Screen)

To enter the Supplementary screen, open “Telephony” menu on the left [menu] panel and select “Supplementary”.

On this screen, Call Forwarding, Call Waiting and Call Barring are set.

Also, Voice Mail Center Address is displayed on this screen.

The screenshot displays the 'Supplementary' configuration page. It is divided into several sections:

- Voice Mail:** Shows the 'Voice Mail Center Address' as 870772001899.
- Call Forwarding:** Includes a 'Read' button and settings for Voice and Audio. For each, there are four conditions: 'All Received Calls', 'Busy', 'Not Reachable', and 'Not Reply'. Each condition has a 'Disable' dropdown menu and an adjacent empty text box. An 'Unanswered Limit' is set to '5 sec' with a 'Set' button.
- Call Waiting:** Includes a 'Read' button and settings for Voice and Audio. Each has a 'Disable' dropdown menu and an adjacent empty text box. A 'Set' button is present.
- Call Barring:** Includes a 'Read' button and settings for Voice and Audio. It lists four conditions: 'All Outgoing Calls', 'Outgoing except home country', 'All Incoming Calls', and 'Incoming except home country'. Each has a 'Disable' dropdown menu and an adjacent empty text box. A 'Network PIN' field and a 'Set' button are also visible.

Fig. 6.5.2.3 Supplementary Screen

Get Voice Message

Dial up the displayed number.

Example) → 00870772001899#

Enable Call Forwarding

Select “Enable” for the condition for calls to be forwarded, and the box lying on the right side of the pull-down menu will be activated. And then, enter the destination for call forwarding with 00 on the head of the number. Click Set button to register the setting.

Example) To forward +81-422-45-9xxx, in Japan → Enter “0081422459xxx”

6. Web Menu System

Indicate Call Waiting

Select “Enable” for the service type for call waiting to be indicated, and then click Set button. The call waiting indication tone is two beeps every three seconds. Refer to [5.1.7 Handling Call Waiting (Handset)](p5-13) or [5.2.3 Handling Call Waiting (TEL port)](p5-32) for how to handle call waiting.

Reject Incoming/Outgoing call

Select “Enable” for conditions for calls to be rejected. Beware that “Enable” makes the call reject. To set call barring, Network PIN Code is required. Enter the PIN Code and click Set button.

Network PIN Code has no initial setting. The number (from 8 to 16 digits) which is input for the first time shall be applied as the Network PIN Code. If forgot the Network PIN, changing Call Barring settings will be disabled. Please do not forget the Network PIN Code.

6.5.3 Port Menus

Port menu is on the left [menu] panel.

In this menu, user can set up each port.

Port Menu contains following screens.

- Handset Screen (Sec. 6.5.3.1 Set Handset)
- ISDN Screen (Sec. 6.5.3.2 Set MSN)
- Ethernet Screen (Sec. 6.5.3.1 Set User LAN and Ext WAN)
- I/O Screen (Sec. 6.5.3.4 Set Input/Output Signal)
- Option Screen (Sec. 6.5.3.5 Set Option Button and Buzzer)

6.5.3.1 Set Handset (Handset Screen)

To enter the Handset screen, open “Port” menu on the left [menu] panel and select “Handset”.

On this screen, user can adjust Handset (brightness of LCD screen/LEDs, volume/pattern of ringer tone, voice volume, and key click sound).

The screenshot shows the 'Handset' configuration screen. It features a title 'Handset' with a small circular icon. Below the title, there are six rows of settings, each with a label on the left and a dropdown menu on the right. The settings are: Back Light (4), Dimmer (4), Ring Type (1), Ring Volume (3), Voice Volume (3), and Click Tone (Enable). A 'SET' button is located at the bottom right of the screen.

Fig. 6.5.3.1 Handset Screen

Table. 6.5.3.1 Contents of Handset Screen

Display		Contents
1)	Back Light	Brightness of LCD. (4 is the brightest)
2)	Dimmer	Brightness of Handset LED. (4 is the brightest)
3)	Ring Type	Ring type of Handset. (6 patterns)
4)	Ring Volume	Ring volume of Handset. (3 is the loudest)
5)	Voice Volume	Voice volume of Handset. (3 is the loudest)
6)	Click Tone	Enable or disable the click tone.
7)	SET	Registers the setting contents

6.5.3.2 Set MSN and ISDN Service type (ISDN Screen)

To enter the ISDN screen, open “Port” menu on the left [menu] panel and select “ISDN”.

The MSN (Multiple Subscribe Number) for each service type on ISDN port can be set on this screen. These numbers are effective only when the connected device supports those service types.

PBX-MSN is used when the ISDN port was specified for internal call (p5-32), Quick Forwarding (p5-33) and Talk Forwarding (p5-33).

For details about MSN and ISDN port, refer to [Sec. 8 Using ISDN port](p8-1).

ISDN Service Type is also set on this screen. Select audio companding type from ETSI (A-low) and INS64 (μ -low).

The screenshot shows the 'ISDN' configuration screen. It is divided into two main sections: 'MSN' and 'ISDN Setting'.
The 'MSN' section contains five rows, each with a service type label and a text input field containing the number '12345678':
- Voice-MSN: 12345678
- Audio-MSN: 12345678
- UDI-MSN: 12345678
- RDI-MSN: 12345678
- PBX-MSN: 12345678
A 'Set' button is located to the right of the PBX-MSN input field.
The 'ISDN Setting' section contains one row with the label 'Service Type' and a dropdown menu currently showing 'INS64'. A 'Set' button is located to the right of the dropdown menu.

Fig. 6.5.3.2 ISDN Screen

NOTE

UDI/RDI service is not available for JUE-251 even when the device connected to TA supports them and you set their MSN.

6.5.3.3 Set User LAN and Ext WAN (Ethernet Screen)

To enter the Ethernet screen, open “Port” menu on the left [menu] panel and select “Ethernet”.

A simple User LAN Setting and Ext WAN setting are executed on this screen.

The setting of User LAN registered here is reflected to VLAN1. For further information about VLAN, refer to [Sec. 6.5.5.6 Further Setting for User LAN](p6-66). A maximum of total 32W PoE (Power over Ethernet) is available on User LAN.

Ext WAN means external WAN other than FBB system like VSAT. Setting of Ext WAN is necessary for using WAN Selector function. Refer to [Sec. 6.5.5.9 Coexistence with Other WAN](p6-71) for WAN Selector.

Fig. 6.5.3.3 Ethernet Screen

Table 6.5.3.3a Contents of Ethernet Screen

User LAN		Contents
1)	IP Address*1)	IP address of JUE-501/JUE-251 for User LAN
2)	Subnet Mask	Subnet Mask for User LAN It defines network address of User LAN.
3)	DHCP	When DHCP function is enabled, it allocates IP addresses automatically to the devices connected to User LAN ports.
4)	DHCP Start Address*1) *2)	Start IP address for the DHCP allocation
5)	DHCP Count*2)	The maximum amount of IP address for DHCP allocation. DHCP Count range: 1 to 254
6)	Set	Registers User LAN contents
EXT WAN		Contents
7)	IP Address*1)	IP address of JUE-501/JUE-251 for Ext WAN I/F
8)	Subnet Mask	Subnet Mask for Ext WAN I/F It defines network address of Ext WAN.
9)	Set	Registers Ext WAN contents

6. Web Menu System

*1) About IP address input

IP address is configured with period-separated 4 strings of numbers.

Example) 192.168.128.100 or 10.20.30.0

Possible input range of IP Address:

10. 0.0.1 – 10.255.255.254
172.16.0.1 – 172.31.255.254
192.168.0.1 – 192.168.255.254

Use of “all ones” or “all zeros” for the host field of the IP address is not
--

*2) About DHCP

The range of IP address allocated by DHCP must not exceed network address defined by parameter 1) and 2).

Table 6.5.3.3b Initial settings of Ethernet port

Port	Parameter	Value
User LAN	IP Address	192.168.128.100
	Subnet Mask	255.255.255.0
	DHCP	Enable
	DHCP Start Address	192.168.128.101
	DHCP Count	16
Ext WAN	IP Address	192.168.0.4
	Subnet Mask	255.255.255.0

6.5.3.4 Set Input/Output signal (I/O Screen)

To enter the I/O screen, open “Port” menu on the left [menu] panel and select “I/O”.

On this screen, user can set input/output of acknowledgement/indication from/to the device connected to the Junction Board. A maximum of two output devices and two input devices can be connected to Junction Board at a time.

Fig. 6.5.3.4 I/O Screen

Table 6.5.3.4 Contents of I/O Screen

Output / Input		Contents
1)	Control	Use or non-use of the I/O port
2)	Function	Function of “Output” is fixed at “Ring Indication” and that of “Input” is also fixed at “Ring Acknowledge” in current version.
3)	Polarity	“Active High” means the function is executed by the higher of two voltages. “Active Low” means the function is executed by the lower of two voltages. (For the Output devices, “Active High” and ”Active Low” is controlled by their connection to the Junction Board.)
4)	Set	Registers the Output / Input settings.
Function		Contents
5)	Type	Select the service type to activate output.
6)	Set	Registers the Function settings.

6.5.3.5 Set Option Button and Buzzer (Option Screen)

To enter the Option screen, open “Port” menu on the left [menu] panel and select “Option”. The service type for which Option Buzzer to be rung can be set on this screen. System reboot is required to change these settings.

Option Buzzers are connected to the Junction Board and ring when a set service call arrived to the main unit.

	Voice	Fax/Audio	UDI	RDI	
Option Buzzer1	Enable	Enable	Enable	Enable	Set
Option Buzzer2	Enable	Enable	Enable	Enable	
Option Buzzer3	Enable	Enable	Enable	Enable	
Option Buzzer4	Enable	Enable	Enable	Enable	

Fig. 6.5.3.5 Option Screen

Enable Option Buzzer

Select “Enable” for services for the buzzer to ring. Click Set button to register the setting.

NOTE

- UDI/RDI service is not available for JUE-251.
- A maximum of four Option Buzzers can be connected.

6.5.4 User Control Menu

User Control menu is on the left [menu] panel.

In this menu, user/device registration for login can be executed. Restriction of communication for registered users and devices is also set in this menu.

User Login

Login made by user name and Secret Code. User Login needs that the user is registered in advance. Refer to [Sec.6.5.4.1 Register Users](p6-45) for more information about User Registration.

Device Reorganization

JUE-501/JUE-251 recognizes a terminal automatically with the IP address when it has been registered in advance. This is convenient for the devices which can not handle “user login” like cameras to connect internet. For more information about device registration, see [Sec.6.5.4.2 Register Devices] (p6-47).

User Control Menu contains following screens.

- User Registration Screen (Sec. 6.5.4.1 Register Users)
- Device Registration Screen (Sec. 6.5.4.2 Register Devices)
- Usage Restriction Screen (Sec. 6.5.4.3 Restrict User Connection)

6.5.4.1 Register Users (User Registration Screen)

To enter the User Registration screen, open “User Control” menu on the left [menu] panel and select “User Registration”.

Registering new user, editing existing user and deleting user can be executed on this screen.

A maximum of 50 users can be registered.

ID	1) Level	2) Name	5) WAN Profile	3) Secret Code	6) Multi Connect	4) Restriction	7) Quick Connect	Set/Del
1	ADMIN	ADMIN	Profile1	0001	Enable	Disable	Enable	Set
2	GUEST	Guest	Disable	Disable	Disable	Restriction1	Disable	Set
3	ADMIN	Mike	Profile2	1010	Enable	Restriction2	Disable	8) Set 9) Del

Fig. 6.5.4.1 User Registration Screen

NOTE

- * Beware that once the data is deleted, it won't be recovered again.
- * User 01 is reserved for an Admin user. You can not delete it nor can edit its level.
- * User 02 is reserved for Guest user. You can not delete it nor can edit its level, name and Secret Code.

Table 6.5.4.1 Contents of User Registration Screen

Display		Contents
1)	Level	Level of the user. User with "Admin" level can browse and set Admin menu located in the [menu] panel of Web interface. Level of the user is displayed on the [Headline] of Web interface.
2)	Name	Name of the user. This name is displayed on the [Headline] of Web interface and used in Call Log. This field allows less than 10 alphanumeric characters.
3)	Secret Code	4 digits. Range: 0001 to 9000 This code is used to log in (User Login) or to recognize the user when a secret call was made.
4)	Restriction	Restriction of connections. The Restrictions listed on this menu are set in [Sec. 6.5.4.3 Restrict User Connection](p6-48). When "Disable" is selected, communication of the user is unlimited.
5)	WAN Profile	WAN Profile used for data connections. This profile arranges data connection (refer to [Sect. 6.4.2 Connect to the Internet (p6-14)]) for the user. For more information about WAN profile, refer to [Sec. 6.5.5.1 Set WAN profile (p6-50)].
6)	Multi Connect	Permission to connect and to disconnect internet connection for someone else on Data Connection screen.
7)	Quick Connect	Permission to use "Quick Connect" on Dashboard screen.
8)	Set	Registers the user.
9)	Del	Deletes the user.

6.5.4.2 Register Devices (Device Registration Screen)

To enter the Device Registration screen, open “User Control” menu on the left [menu] panel and select “Device Registration”.

Registering new device, editing existing device and deleting device can be executed on this screen. A maximum of 50 devices can be registered.

The screenshot shows the 'Device Registration' screen with a table of registered devices. The table has the following columns: ID, 1) IP, 2) Device Name, 3) Restriction, 4) WAN Profile, 5) Multi Connect, 6) Quick Connect, 7) Set, and 8) Del. There are three rows of device information visible.

ID	1) IP	2) Device Name	3) Restriction	4) WAN Profile	5) Multi Connect	6) Quick Connect	7) Set	8) Del
1	192.168.128.181	PC_0	Disable	Disable	Enable	Enable	Set	Del
2	192.168.128.182	PC_1	Restriction2	Disable	Disable	Disable	Set	Del
	192.168.1.103	PC_2	Restriction3					

Fig. 6.5.4.2 Device Registration Screen

NOTE

* Beware that once the data is deleted, it won't be recovered again.

Table 6.5.4.2 Contents of Device Registration Screen

Display		Contents
1)	IP	IP address for the device. To use static IP address for the device, set Static DHCP (refer to [Sec. 6.5.5.7 Use Static IP Address (p6-68)]) or set the IP address manually.
2)	Device Name	Name of the device. This name is displayed on the [Headline] of Web interface and used in Call Log. This field allows less than 10 alphanumeric characters.
3)	Restriction	Restriction of connections. The Restrictions listed on this menu are set in [Sec. 6.5.4.3 Restrict User Connection (p6-48)]. When “Disable” is selected, communication of the device is unlimited.
4)	WAN Profile	WAN Profile used for data connections. This profile arranges data connection (refer to [Sect. 6.4.2 Connect to the Internet (p6-14)]) for the device. For more information about WAN profile, refer to [Sec. 6.5.5.1 Set WAN profile (p6-50)].
5)	Multi Connect	Permission to connect and to disconnect internet connection for someone else on Data Connection screen.
6)	Quick Connect	Permission to use “Quick Connect” on Dashboard screen.
7)	Set	Registers the device.
8)	Del	Deletes the device.

6. Web Menu System

6.5.4.3 Restrict User Connection (Usage Restriction Screen)

To enter the Usage Restriction screen, open “User Control” menu on the left [menu] panel and select “Usage Restriction”.

On this screen, Restriction groups for communication up to five can be set. The limitations are set by time (minutes) for Voice, Audio, UDI, RDI and Streaming IP, by number for SMS and by size (Mbyte) for Standard IP. User/Device can communicate within the assigned Restriction group. These settings are used in [6.5.4.1 Register Users (p6-45)] and [6.5.4.2 Register Devices (p6-47)].

To restrict communications by user/device name, assign restriction group registered here to users and devices (refer to [6.5.4.1 Register Users (p6-45)] and [6.5.4.2 Register Devices (p6-47)]) and enable “Secret Code” for each port to recognize communicating user (refer to [6.5.2.1 Set up Ports (p6-34)]). The call is made by GUEST user on ISDN port because it does not support “Secret Code”.

Also, user can select reset cycle from “Manually”, “Monthly”, “Weekly” or “Daily” to initialize the counts of time and size.

NOTE

- UDI/RDI service is not available for JUE-251.
- Beware that the restriction assigned to the Guest user is applied for ISDN port because ISDN port doesn't recognize Secret Code.

Restriction Name	Type	Permission	Time/Size	Type	Permission	Time/Size	Set/Del
Restriction1	Voice	Limited	50000 min	SMS	Limited	50000 mails	Set Del
	Audio	Limited	50000 min	Standard	Limited	2000 Mbyte	
	UDI	Limited	50000 min	Streaming	Limited	50000 min	
	RDI	Limited	50000 min				

Fig. 6.5.4.3a Usage Restriction (Restriction Setting) Screen

Set Restriction Group

Step1: Enter the name of Restriction. The name set here is displayed on Restriction menu of User Restriction screen ([6.5.4.1 Register Users]) and Device Registration screen ([6.5.4.2 Register Devices]).

Step2: Select Permission for each service types. Limitation time/number/size is required when “Limited” is selected.

Step3: Click “Set” button to register the Restriction group.

Delete Restriction Group

(Permission is set to “Unlimited” for all service types when the Restriction is deleted.)

Click “Del” button for the Restriction group.

Reset Cycle setting menu is on the bottom of this page. Reset Cycle defines the cycle to reset the count of communication time and size

Fig. 6.5.4.3b Usage Restriction (Reset Cycle Setting) Screen

Set Reset Cycle

Step1: Select the “Term” from Manually, Monthly, Weekly and Daily. The following boxes are activated as your “Term” selection.

Step2: Click “Set” button to register your Reset Cycle.

If you select “Manually”, you need to reset the count regularly.

Reset the Count Manually

Just click “Reset” button.

6.5.5 Network Menu

Network menu is on the left [menu] panel.

In this menu, user can design flexible Local Area Network.

Network Menu contains following screens.

- WAN Profile Screen (Sec. 6.5.5.1 Set WAN Profile)
- Packet Filter Screen (Sec. 6.5.5.2 Set Packet Filter)
- Always Activate Screen (Sec. 6.5.5.3 Set Permanent Connection)
- Remote Activate Screen (Sec. 6.5.5.4 Establish Remote Connection)
- LAN Group Screen (Sec. 6.5.5.5 Set LAN Group)
- LAN Screen (Sec. 6.5.5.6 Further Settings for User LAN)
- Static DHCP Screen (Sec. 6.5.5.7 Use Static IP Address)
- Routing Table Screen (Sec. 6.5.5.8 Set Routing Table)
- WAN Selector Screen (Sec. 6.5.5.9 Coexistence with Other WAN)

6.5.5.1 Set WAN Profile (WAN Profile Screen)

To enter the WAN Profile screen, open “Network” menu on the left [menu] panel and select “WAN Profile”.

On this screen, WAN Profiles up to five are defined.

WAN profile defines service type, settings of APN, Global IP Address, connection mode, WAN filter, settings for VPN and secondary service type. WAN profile is used as a template for regulating data connection on User Registration screen, Device Registration screen, Always Activate screen and Remote Activate screen.

WAN Profile

Select Profile: Profile1 (1) View (2)

Profile Setting

Group Name	Parameter
Profile1 (3)	Service Type (4) Standard & Streaming max rate 256 kbps
	Edit (5) Permitted
Set Default (9)	APN (6) SIM Default bgan.inmarsat.com
	APN User / Password (7)
Advance Mode (10)	Global IP (8) Dynamic
	Set (11)

Fig. 6.5.5.1a WAN Profile Screen

Table 6.5.5.1a Contents of WAN Profile Screen

Select Profile		
1)	Select Profile	Select the profile to configure.
2)	View	Displays the selected Profile.
Profile Setting		
3)	Group Name	Name of the profile The name set here is displayed as profile name on User Registration screen, Device Registration screen, Always Activate screen and Remote Activate screen.
4)	Service Type	Service type for data connection. Max rate is required when “Streaming Only” or “Standard & Streaming” is selected.
5)	Edit	Whether this profile permits the assigned users to edit it on Data Connection screen or not.
6)	APN	Access Point Name
7)	APN User/ Password	User name and Password for APN. The password will be hidden by ● when it entered.

8)	Global IP	Select Dynamic or Static for Global IP address used in this profile. Global IP address is required only when Static is selected.
9)	Set Default	Reset the settings to the default.
10)	Advance Mode	Get into advanced configuration. (Refer to Table 6.5.5.1b)
11)	Set	Registers the profile.

■ Advance Mode

When Advance Mode button (explained by 10) of Table 6.5.5.1a) is clicked, the Advance Mode button will change into Normal Mode button and advanced configuration will be displayed.

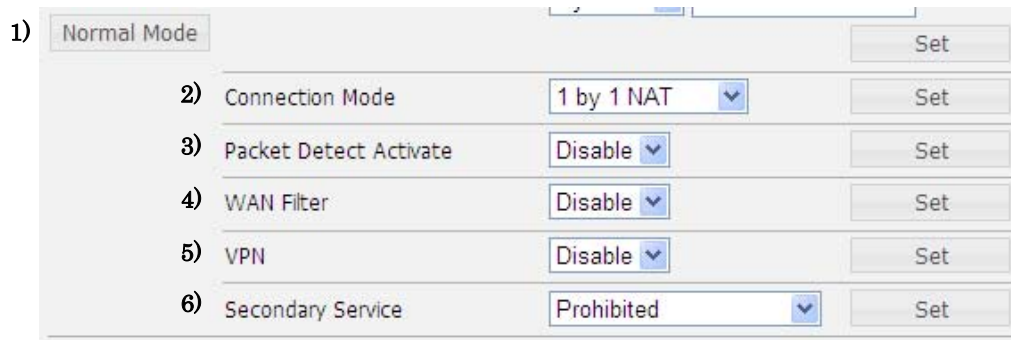

Fig. 6.5.5.1b WAN Profile Advanced Screen

Table 6.5.5.1b Contents of WAN Profile Advanced Screen

Display		Contents
1)	Normal Mode	Hides advanced configurations.
2)	Connection Mode	Selection for Communication Mode. LAN Group selection menu will appear when "IP Masquerade" is selected. (Refer to Table 6.5.5.1c) Click Set button to activate the setting.
3)	Packet Detect Activate	Packet Detect Activate is a function that automatically connects Standard IP Connection by detecting outgoing packet when main unit is ready to connect PS Connection (PS READY). The Standard IP Connection connected by this function will be disconnected by Auto disconnect function if Auto disconnect function is activated.
<p>NOTE</p> <ul style="list-style-type: none"> • There is a possibility to connect unexpected PS Connection by the settings or operation of terminal connected to Ethernet port. And if packet was sent or received through this connection, communication fee will be charged. Thus be careful to block an unexpected packet by using Packet Filter and modifying settings of the terminal etc. • JRC is indemnified for any communication fee troubles using this function except as outlined in the product warranty and by limitation of law. • Distribution partner of SIM card might charge a communication fee by only connecting and disconnecting Standard IP Connection. • Do not overlap IP address range setting of this function with Always Activate function. 		

6. Web Menu System

	NOTE	
	<ul style="list-style-type: none"> This function does not work when the selected profile doesn't support Standard IP connection as its service type. This function does not work for the user "GUEST" when IP Masquerade is selected for their Connection Mode. 	
4)	WAN Filter	Packet data filter (Refer to Table 6.5.5.1d)
5)	VPN	Setting for VPN (Virtual Private Network). VPN setting menu will appear when "Enable" is selected. (Refer to Table 6.5.5.1e)
6)	Secondary Service Type	Setting for Secondary Service Type. Secondary Service Type setting menu will appear when a service type is selected. (Refer to Table 6.5.5.1f)

● Connection Mode

Connection Mode selects "1by1 NAT" or "IP Masquerade".

When "1by1 NAT" is selected for Communication Mode, user terminal using this WAN Profile will be associated by one-to-one with global IP assigned by inmarsat.

When "IP Masquerade" is selected for Communication Mode, LAN Group selection menu will appear. LAN Group is a unit to which IP masquerade is applied. With "IP Masquerade" mode, the network defined by LAN Group shares the global IP address assigned by inmarsat. Refer to [Sec. 6.5.5.5 Set LAN Group (p6-64)] for more information about LAN Group. Set the Connection Mode and click Set button.



Fig. 6.5.5.1c Connection Mode menu

Table 6.5.5.1c Contents of Connection Mode menu

Display		Contents
1)	Connection Mode	Selection for Communication Mode. LAN Group selection menu will appear when "IP Masquerade" is selected.
2)	LAN Group	LAN Group (a unit to which IP masquerade is applied) Refer to [Sec. 6.5.5.5 Set LAN Group] for more information.
3)	Set	Registers the Connection Mode.

● WAN Filter

When “Enable” is selected for WAN Filter, WAN Filter menu will appear. A maximum of 30 WAN filters can be set for each WAN profile. JUE-501/JUE-251 can pass/drop an incoming/outgoing packet by setting. It has no filters in the initial state, so it will pass all packets.

JUE-501/JUE-251 gives higher priority to MAC filter ([Sec. 6.5.5.6 Further Settings for User LAN (p6-66)]) than any other WAN filter. There is no preference between WAN filters and packet filters ([Sec. 6.5.5.2 Set Packet Filter (p6-57)]). Just coordinate the “Priority” to make the preference. JUE-501/JUE-251 gives higher priority to Packet Filter when the same “Priority” was set to a Packet filter and a WAN filter.

Fig. 6.5.5.1d WAN Filter menu

NOTE

- * WAN filters are not applied to the connections established before setting up them.
- * WAN filters are not applied to the Ext WAN.
- * “Packet Detect Activate function” will establish a PS connection even when a packet to be dropped by WAN filter was made. WAN filters drop the targeting packet data after the PS connection is established. Please use Packet Filter ([Sec. 6.5.5.2 Set Packet Filter (p6-57)]) to restrict the establishment of PS connections by PDA.

Table 6.5.5.1d Contents of WAN Filter menu

Display		Contents
1)	WAN Filter	Use or non-use of WAN filters
2)	Priority	Order of priority for WAN Filter setting Range: 1 to 255 (The highest priority is 1 and the lowest priority is 255.)
3)	Action	Setting whether to Pass or Drop the packet.
4)	Protocol	Setting the protocol (Disable / ALL / TCP / UDP / ICMP / Select No.) to filter. When “Select No.” is selected, protocol number can be input. When TCP/UDP is selected, WAN Port 5) and Internet Port 7) can be input. When “Disable” is selected, the filter is deleted.
5)	WAN Port	The TCP/UDP port number on JUE-501/JUE-251 Destination port when “<-“ (incoming) is selected. Source port when “->“ (outgoing) is selected.

6. Web Menu System

		<p>“-” represents range. Ex) 20-80 set from 20 to 80.</p> <p>When it remains blank, the filter is adopted to all TCP/UDP port.</p>
6)	Direction	<p>Direction of the filter</p> <p>“<-“ means “incoming” and “->” means “outgoing”.</p>
7)	Internet Port	<p>The TCP/UDP port number on 8) Internet IP</p> <p>Source port when “<-“ (incoming) is selected.</p> <p>Destination port when “->“ (outgoing) is selected.</p> <p>“-” represents range. Ex) 20-80 set from 20 to 80.</p> <p>When it remains blank, the filter is adopted to all port.</p>
8)	Internet IP	<p>Target IP address for the filter</p> <p>Source IP address when “<-“ (incoming) is selected.</p> <p>Destination IP address when “->“ (outgoing) is selected.</p> <p>When it remains blank, the filter is adopted to all IP address.</p>
9)	Set	Registers the WAN filters.

● VPN

When “Enable” is selected for VPN, VPN menu will appear. Set the VPN and click Set button.

Fig. 6.5.5.1e VPN menu

Table 6.5.5.1e Contents of VPN menu

Display		Contents
1)	VPN	Enable/Disable VPN
2)	Remote Global IP	Global IP address of destination (remote VPN server)
3)	Pre-shared Key	Password for the VPN connection
4)	Local ID Authentication	<p>The setting method of certification ID</p> <ul style="list-style-type: none"> • IP Global IP address of JUE-501/JUE-251. You should not use it without Static Global IP address. Whether you can use static global IP address or not depends on your contract. • FQDN (Default) The text box of “Local ID” is activated when “FQDN” is selected. Input FQDN.

		<ul style="list-style-type: none"> User FQDN <p>The text box of “Local ID” is activated when “User FQDN” is selected. Input User FQDN. (A form of username@domainname)</p>
5)	Local ID	User ID to notify the remote VPN server
6)	Remote Network Address	Remote (Destination) Network Address
7)	Remote Network Mask	Remote (Destination) Network Mask
8)	Set	Registers the VPN settings.

Setting of remote VPN server is necessary to establish VPN connection. Follow the instruction manual of VPN server to set it up. About the VPN server setting on JUE-501/251, refer to Appendix G “JUE-501/251 VPN setting”

● Secondary Service

When a service type is selected for Secondary Service Type, Secondary Service Type menu will appear. Set the Secondary Service Type and click Set button.

When “Secondary Service” is set to other than "Prohibit" and connect “Secondary Service” on Data Connection screen, it holds two lines for one Global IP address.

Packet data within the “Uplink Traffic Flow Filter” or “Downlink Traffic Flow Filter” pass through the Secondary Service.

Fig. 6.5.5.1f Secondary Service Type menu

Table 6.5.5.1f Contents of Secondary Service Type menu

Display		Contents
1)	Secondary Service	Service type for secondary service
2)	max rate	Max rate for secondary service. (For Streaming service only.)
3)	Set	Registers the Secondary Service settings.
Uplink Traffic Flow Filter		Contents

6. Web Menu System

4)	Destination Address	Destination address adapting Uplink Traffic Flow Filter When it remains blank, the filter is adopted to all IP address.
5)	Subnet Mask	Subnet mask for adapting Uplink Traffic Flow Filter
6)	Protocol No.	Protocol number for adapting Uplink Traffic Flow Filter Range: 1 to 255 When it remains blank, the filter is adopted to all protocols.
7)	Destination Port Range	Destination Port Range for adapting Uplink Traffic Flow Filter Range: 1 to 65535. "-" represents range. Ex) 20-80 set from 20 to 80. When it remains blank, the filter is adopted to all TCP/UDP port.
8)	Source Port Range	Source Port Range for adapting Uplink Traffic Flow Filter Range: 1 to 65535. "-" represents range. Ex) 20-80 set from 20 to 80. When it remains blank, the filter is adopted to all TCP/UDP port.
9)	Type of Service	Type of service embedded in packet header. Range: 1 to 255 When it remains blank, the filter is adopted to all Type of Service.
10)	Type of Mask	Mask to define adapted type-of-service. Range: 1 to 255 This item is required when "9) Type of Mask" was input.
Downlink Traffic Flow Filter		Contents
11)	Source Address	Source address adapting Downlink Traffic Flow Filter When it remains blank, the filter is adopted to all IP address.
12)	Subnet Mask	Subnet mask for adapting Downlink Traffic Flow Filter
13)	Protocol No.	Protocol number for adapting Downlink Traffic Flow Filter Range : 1 to 255 When it remains blank, the filter is adopted to all protocols.
14)	Destination Port Range	Destination Port Range for adapting Downlink Traffic Flow Filter Range: 1 to 65535. "-" represents range. Ex) 20-80 set from 20 to 80. When it remains blank, the filter is adopted to all TCP/UDP port.
15)	Source Port Range	Source Port Range for adapting Uplink Downlink Flow Filter Range: 1 to 65535. "-" represents range. Ex) 20-80 set from 20 to 80. When it remains blank, the filter is adopted to all TCP/UDP port.
16)	Type of Service	Type of service embedded in packet header. Range: 1 to 255 When it remains blank, the filter is adopted to all Type of Service.
17)	Type of Mask	Mask to define adapted type-of-service. Range: 1 to 255 This item is required when "16) Type of Mask" was input.

6.5.5.2 Set Packet Filter (Packet Filter Screen)

To open the Packet Filter screen, click “Network” menu on the left [menu] panel and select “Packet Filter”.

On the Packet Filter screen, the filters applied to all PS connections (any WAN Profile) are configured. JUE-501/JUE-251 can pass/drop an incoming/outgoing packet by setting packet filters. JUE-501/JUE-251 has no filters in the initial state, so it will pass all the packets between User LAN and Internet and drop all the packets between User LANs. A maximum of 100 packet filters can be set.

JUE-501/JUE-251 gives higher priority to MAC filter ([Sec. 6.5.5.5 Further Settings for User LAN (p6-63)]) than any other filters. There is no preference between WAN filters ([Sec. 6.5.5.1 Set WAN Profile (p6-53)]) and packet filters. Just coordinate the “Priority” to make the preference. JUE-501/JUE-251 gives higher priority to Packet Filter when the same “Priority” was set to a Packet filter and a WAN filter.

Packet Filter

1) Start 2) End 3)

View Range(1-100) 1 10 Disp

4) Priority 5) Action	6) Protocol No.	7) Source IP	8) Source Mask	9) Source Port	10) Destination IP	11) Destination Mask	12) Destination Port	Set	Del
1 Pass	Disable		255.255.255.255/32			255.255.255.255/32		Set	Del
2 Pass	TCP	6		255.255.255.255/32	9000-9100	255.255.255.255/32	80-90	Set	Del
3 Pass	ICMP	1	192.168.128.102	255.255.255.255/32	8.8.8.8	255.255.255.255/32		Set	Del
4 Pass	ICMP	1	192.168.128.116	255.255.255.255/32	8.8.8.8	255.255.255.255/32		Set	Del
5 Pass	UDP	17		255.255.255.255/32	1.2.3.4	255.255.255.255/32		Set	Del
6 Pass	ICMP	1	192.168.128.100	255.255.255.0/24	192.168.129.100	255.255.255.0/24		Set	Del
7 Pass	ICMP	1	192.168.129.100	255.255.255.0/24	192.168.128.100	255.255.255.0/24		Set	Del

Fig.6.5.5.2 Packet Filter Screen

NOTE

* Packet filters are applied to the packets between User LANs and the packets of External WAN as well as the packets between User LAN and the internet.

Table 6.5.5.2 Contents of Packet Filter Screen

View Range		
1)	Start	Minimum ID number to display (1~100)
2)	End	Maximum ID number to display (1~100)
3)	Disp	Display the ID range
Packet Filter		
4)	Priority	Order of priority for packet filter setting Range: 1 to 255 (The highest priority is 1 and the lowest priority is 255)
5)	Action	Setting whether to Pass or Drop the packet
6)	Protocol No.	Setting the protocol (Disable / ALL / TCP / UDP /ICMP / Select No.) to filter When "Select No." is selected, protocol number can be input. When TCP/UDP is selected, Source Port 9) and Destination Port 12) can be input. When "Disable" is selected, the filter is deleted.
7)	Source IP	Packet source IP address to filter When it remains blank, the filter is adopted to all IP Address. Specified with the Source Mask 8), it defines the network address to filter.
8)	Source Mask	Subnetwork Mask for the packet source Select "255.255.255.255/32" to apply the filter only to the Source IP 7).
9)	Source Port	The source TCP/UDP port number of the packets to be filtered “-” represents range. Ex) 20-80 set from 20 to 80. When it remains blank, the filter is adopted to all TCP/UDP port.
10)	Destination IP	Packet destination IP address to filter When it remains blank, the filter is adopted to all IP Address. Specified with the Destination Mask 11), it defines the network address to filter.
11)	Destination Mask	Subnetwork Mask for the packet destination Select "255.255.255.255/32" to apply the filter only to the Destination IP 10).
12)	Destination Port	The destination TCP/UDP port number of the packets to be filtered “-” represents range. Ex) 20-80 set from 20 to 80. When it remains blank, the filter is adopted to all TCP/UDP port.
11)	Set	Set the packet filter

Change the view range of the packet filter

- Step 1: Input the minimum ID number you want to view to the “Start” box.
- Step 2: Input the maximum ID number you want to view to the “End” box.
- Step 3: Click “Disp” button, and the list of ranges you inputted is displayed.

Add new packet filter / Change existing packet filter

- Step 1: Input the filter rule to the text boxes.
- Step 2: Click “Set” button in the same line.

Delete a existing packet filter

- Step 1: Select “Disable” to the “Protocol No.” and click “Set” button in the same line.

Setting of packet filters are applied immediately after the “Set” button is clicked.

6.5.5.3 Set Permanent Connection (Always Activate Screen)

To enter the Always Activate screen, open “Network” menu on the left [menu] panel and select “Always Activate”.

Once Always Activate function is set enabled on this screen, JUE-501/JUE-251 automatically connect and keep Standard IP Connection after the start-up (PS READY) of main unit. (This function will reconnect PS connection when it detects the disconnection by any reason). The Standard IP Connection connected by this function will never be disconnected by Auto disconnect function.

Up to three connections can be set as always-activated connections.

NOTE

- The PS Connection connected by this function never gets disconnected by Auto Disconnect function.
- There is a possibility to get unexpected communication fee charged by sending and receiving unexpected packet through the connection. Thus be careful to block an unexpected packet by using Packet filter and modifying settings of the terminal etc.
- JRC is indemnified for any communication fee troubles using this function except as outlined in the product warranty and by limitation of law.
- Distribution partner of SIM card might charge a communication fee by only connecting and disconnecting Standard IP Connection.
- This function does not work when the selected profile doesn't support Standard IP connection as its service type.
- If you can not send a packet through this connection, disconnect the connection and wait till it reconnects again. Then after that, try to send a packet again.
- Do not overlap IP address range setting of this function with Packet Detection Activate function.

Fig. 6.5.5.3 Always Activate Screen

Table 6.5.5.3 Contents of Always Activate Screen

Display		Contents
1)	Profile	Select the WAN Profile used in the Always Activate connection.
2)	Local IP	Local IP address used in the Always Activate connection. The local IP address is used when “1by1 NAT” was selected for the Connection Mode of the 1) WAN Profile. Leave this column blank when “IP Masquerade” is selected for the connection mode.
3)	Service	Used service type (Fixed to Standard service.)
4)	Set	Registers the Always Activate settings.

Connect Always Activated connection

Step1: Select profile used in this connection from the pull-down menu. The profile must support Standard IP service. For more information about profile, refer to [6.5.5.1 Set WAN Profile].

Step2: Enter the local (private) IP address used in this connection. (The local IP address is applied if “1by1 NAT” was selected for the Connection Mode of the WAN Profile selected at Step1. Leave this column blank when “IP Masquerade” is selected for the connection mode.)

Step3: Click Set button.

Disconnect Always Activated connection

Step1: Select “Disable” in the pull-down menu of “Profile” for the connection you want to disconnect.

Step2: Click Set button.

Step3: Disconnect the target connection on “Data Connection” screen (refer to [Sec.9.2.2 Connect to the Internet]). (If the connection is not yours, you need to be set “Multi Connect” to “Enable” to disconnect it. For more information about “Multi Connect”, refer to [Sec. 6.5.4.1 Register Users] or [Sec. 6.5.4.2 Register Devices].)

6.5.5.4 Establishes Remote Connection (Remote Activate Screen)

To enter the Remote Activate screen, open “Network” menu on the left [menu] panel and select “Remote Activate”.

The settings of “Remote Activate” can be executed on this screen. Anyone who knows user name and password registered here can establish Standard IP connection by sending SMS when “Remote Activate” is set to “Enable”. The connection connected by SMS can be also disconnected by SMS.

NOTE

- There is a possibility to get unexpected communication fee charged by sending and receiving unexpected packet through the connection. Thus be careful to block an unexpected packet by using Packet filter and modifying settings of the terminal etc.
- JRC is indemnified for any communication fee troubles using this function except as outlined in the product warranty and by limitation of law.
- Distribution partner of SIM card might charge a communication fee by only connecting and disconnecting Standard IP Connection.
- This function does not work when the selected profile doesn't support Standard IP connection as its service type.
- The Standard IP connection connected by this function will be disconnected by Auto disconnect function if Auto disconnect function is activated.
- Do not overlap IP address range setting of this function with Packet Detection Activate function.
- This function is case-sensitive.



Fig. 6.5.5.4 Remote Activate Screen

Table 6.5.5.4 Contents of Remote Activate Screen

Display		Contents
1)	Remote Activate	Enable/Disable Remote Activate
2)	User	User name to use Remote Activate

3)	Password	Password to use Remote Activate
4)	Profile	WAN Profile used for Remote Activate The profile must support Standard IP service.
5)	Local IP	Local IP address used for Remote Activate The IP address is applied if “1by1 NAT” was selected for the Connection Mode of the WAN Profile selected at 4).
6)	Service	Service type for Remote Activate This setting is disable (turned gray) in current version.
7)	Set	Registers the Remote Activate settings.

Connect by SMS

Example) Establishing a Standard IP connection by User [JRC] and Password [remote].

Step1: Send SMS message to JUE-501/JUE-251. The text format is shown below.

```
Activate
User
Password
```

Format

```
Activate
JRC
remote
```

Example

*JUE-501/JUE-251 accepts “newline” and “space”.

Step2: Receive SMS report.

```
*Activate
User
IP Global IP
Result
```

Format

```
*Activate
JRC
IP xx.xx.xx.xx
OK
```

Success

```
*Activate
JRC
Password Error
NG
```

Fail

Disconnect by SMS

Example) Disconnecting the Standard IP connection by User [JRC] and Password [remote].

Step1: Send SMS message to JUE-501/JUE-251. The text format is shown below.

```
Deactivate
User
Password
```

Format

```
Deactivate
JRC
remote
```

Example

*JUE-501/JUE-251 accepts “newline” and “space”.

Step2: Receive SMS report.

```
*Deactivate
User
Result
```

Format

```
*Deactivate
JRC
OK
```

Success

```
*Deactivate
JRC
Password Error
NG
```

Fail

6.5.5.5 Set LAN Group (LAN Group Screen)

To enter the LAN Group screen, open “Network” menu on the left [menu] panel and select “LAN Group”.

On this screen, user can define LAN Groups. A LAN Group is a unit to which IP masquerade is applied. LAN Groups defined here are used as options when “IP Masquerade” has been selected for “Connection Mode” on WAN Profile screen (refer to Table 6.5.5.1b 2)).

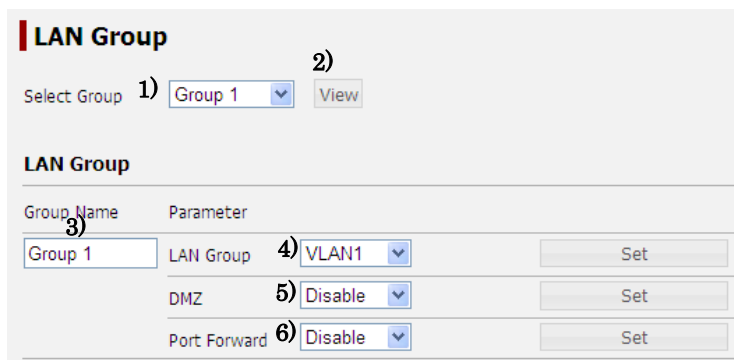

Table 6.5.5.5a Contents of LAN Group Setting Screen

Fig. 6.5.5.5a LAN Group Setting Screen

Display	Contents
1) Select Group	Select the LAN Group to configure.
2) View	Displays the selected LAN Group.
3) Group Name	Name of the LAN Group The name set here is used in “Connection Mode” on WAN Profile screen (refer to Table 6.5.5.1b 2)).
4) LAN Group	LAN Group (a unit to which IP masquerade is applied) Manual setting menu will appear when “Manual” is selected. (Refer to Table 6.5.5.5b)
5) DMZ	Setting for DMZ (DeMilitarized Zone) Transferring destination menu will appear when “Enable” is selected. (Refer to Table 6.5.5.5c)
6) Port Forward	Setting for Port Forwarding

● LAN Group

LAN Group can be a VLAN or manually defined network. When “Manual” is selected for “LAN Group”, manual setting menu for “LAN Group” will appear. Input settings for the network and click “Set” button.

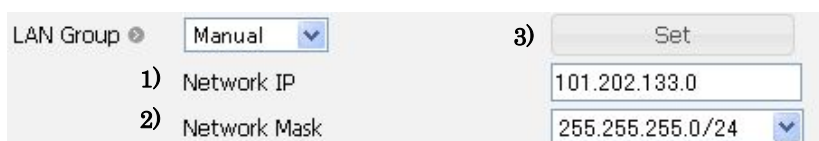

Fig. 6.5.5.5b Manual setting menu for LAN Group

Table 6.5.5.5b Contents of Manual setting menu for LAN Group

Display	Contents
1) Network IP	Network address for the LAN Group

2)	Network Mask	Subnet Mask to define the range of the LAN Group
3)	Set	Registers the LAN Group.

● DMZ

When “Enable” is selected for “DMZ”, it transfers all packet data from the internet to the local IP address defined here.

Fig. 6.5.5.5c Transferring menu for “DMZ”

● Port Forward

When “Enable” is selected for “Port Forward”, it transfers the packet data which is under the conditions of the "Port Forwarding List" to the destination defined in it. On JUE-501/JUE-251, “Port Forward” has higher priority than “DMZ”. So, the packet data listed in this setting will be transferred to the listed destinations even when “DMZ” has been enabled.

Fig. 6.5.5.5d Port Forward setting

Add new Forwarding List

Step1: Select the protocol type (TCP or UDP) to be transferred.

Step2: Input the WAN port number from which you want the data packets to be transferred.

Port range: 1 to 65535.

Step3: Input the destination (local IP address) for transferring the data.

Step4: Input the LAN port number to which you want the data packets to be transferred.

Port range: 1 to 65535.

Step5: Click “Set” button.

Delete a Forwarding List

Step1: Select the protocol type “Disable”.

Step2: Click “Set” button.

NOTE

“DMZ” and “Prot forward” set here are not applied to the connections established before setting up them.

6.5.5.6 Further Settings for User LAN (LAN Screen)

To enter the LAN screen, open “Network” menu on the left [menu] panel and select “LAN”.

On this screen, user can set a maximum of four VLANs (Virtual LAN) and a maximum of 50 MAC filters. The setting executed by [Sec. 6.5.3.3 Set User LAN and Ext WAN (p6-41)] is registered to VLAN1. This screen consists of three parts “Port Tagging”, “VLAN Setting” and “MAC Filter”.

1. Port Tagging

Port	VLAN1	VLAN2	VLAN3	VLAN4
Port 1	<input checked="" type="radio"/>	<input type="radio"/>	<input type="radio"/>	<input type="radio"/>
Port 2	<input checked="" type="radio"/>	<input type="radio"/>	<input type="radio"/>	<input type="radio"/>
Port 3	<input checked="" type="radio"/>	<input type="radio"/>	<input type="radio"/>	<input type="radio"/>
Port 4	<input checked="" type="radio"/>	<input type="radio"/>	<input type="radio"/>	<input type="radio"/>

Fig. 6.5.5.6a Port Tagging

Select the VLAN for the User LAN port to belong and click “Set” button. The right end in User LAN port is assigned as Port1 and the left end is assigned as Port4.

In the initial state, all the User LAN port belongs to VLAN1.

2. VLAN Setting

1) VLAN	2) VLAN	3) IP Address	4) Subnet Mask	5) DHCP	6) Start IP	7) Count	8) SET
VLAN1	Enable	192.168.128.100	255.255.255.0/24	Enable	192.168.128.1	50	Set
VLAN2	Disable		255.0.0.0/8	Disable			Set
VLAN3	Enable	192.168.160.100	255.255.255.0/24	Disable			Set
VLAN4	Disable		255.0.0.0/8	Disable			Set

Fig. 6.5.5.6b VLAN Setting

NOTE

Your DHCP might not work when the setting of VLAN has been changed. Please check your DHCP settings (including Static DHCP) before changing VLAN setting.

Please disconnect all the packet connection before attempting to change VLAN setting. Restart the main unit if by any chance the VLAN setting should be changed with PS connected.

Table 6.5.5.6b Contents of VLAN Setting

Display		Contents
1)	VLANn	n is VLAN number
2)	VLAN	Enable/Disable the VLAN When set to “Enable”, following settings is required. “Disable” can not be selected for VLAN1.
3)	IP Address*1)	IP address of JUE-501/JUE-251 for the VLAN. (The main unit has one IP address for one VLAN.)
4)	Subnet Mask	Subnet Mask to define the range of VLAN
5)	DHCP*2)	Enable/Disable DHCP server When DHCP function is enabled, it allocates IP addresses automatically to the devices connected to the VLAN.
6)	Start IP*1) *2)	Minimum IP address for the DHCP allocation
7)	Count*2)	The total amount of IP address number for DHCP allocation. Count range: 1 to 254
8)	Set	Registers the setting.

***1) About IP address input**

IP address is configured with period-separated 4 strings of numbers.

Example) 192.168.128.100 or 10.20.30.0

Possible input range of IP Address:

10. 0.0.1 – 10.255.255.254
172.16.0.1 – 172.31.255.254
192.168.0.1 – 192.168.255.254

Use of “all ones” or “all zeros” for the host field of the IP address is not
--

***2) About DHCP**

The range of IP address allocated by DHCP must not exceed the range of VLAN defined by parameter 3) and 4).

Hint

If you want to use Static DHCP only and don't want to use Dynamic DHCP, set “DHCP” to “Enable” and “Start IP” to blank.

3. MAC Filter

Once MAC Filter is enabled, all the packet data except for the data transmitted or received by permitted MAC address can not pass through the main unit. MAC filter has a higher priority than any other WAN filter. A maximum of 50 MAC filters can be registered.

6. Web Menu System

ID	Permitted MAC Address	Set	Delete
1	<input type="text"/>	Set	Delete
2	<input type="text"/>	Set	Delete
3	<input type="text"/>	Set	Delete

Fig. 6.5.5.6c MAC Filter Setting

Change the view range of the MAC filter list

- Step1: Input the minimum ID number you want to view to the “Start” box.
- Step2: Input the maximum ID number you want to view to the “End” box.
- Step3: Click “Disp” button, and the list of ranges you inputted is displayed.

Add new permitted MAC address

- Step1: Input a MAC address to a text box. Packet data from and to the address is permitted to pass the main unit.
 - Step2: Click “Set” button in the line.
- MAC address is configured with colon-separated 6 strings of numbers and alphabets.
Example) 08:00:20:9E:7F:04

Delete permitted MAC address

- Step1: Click “Del” button in the line

NOTICE

Access to the main unit by Web Menu or Launch Pad remains available even if the MAC address is not listed to the “Permitted MAC Address”.

MAC Filter restricts the packet data flow to the internet attempted by the devices which has not been listed on "Permitted MAC Address".

6.5.5.7 Use Static IP Address (Static DHCP Screen)

To enter the Static DHCP screen, open “Network” menu on the left [menu] panel and select “Static DHCP”.

You may want to use static IP address for a device to manage network or to use Device Registration. The list of IP address and MAC address on the upper part of this screen is the setting list for allocating the static IP address to the MAC address. The list of lower part of this screen shows the combination of MAC address and its IP address being allocated by DHCP at that time.

User can set a maximum of 50 combinations of IP address and MAC address for static DHCP.

NOTE

* Check your LAN setting on LAN screen (refer to [6.5.5.6 Further Setting for User LAN (p6-66)]). The device cannot connect to JUE-501/JUE-251 when the IP address was allocated beyond the LAN.

The screenshot shows the 'Static DHCP' configuration screen. It is divided into two main sections: 'Setting List' and 'Active List'.

Setting List: This section contains a table with two columns: 'IP Address' and 'MAC Address'. Each row has a 'Set' button and a 'Delete' button to its right. The entries are as follows:

IP Address	MAC Address	Set	Delete
192.168.128.108	12:34:56:78:9A:88	Set	Delete
10.20.30.1	AA:34:56:78:9A:81	Set	Delete
192.168.128.110	26:3E:56:78:9A:4A	Set	Delete
192.168.128.109	3C:34:56:78:9A:5D	Set	Delete
192.168.1.100	8E:34:56:78:9A:14	Set	Delete
10.20.30.2	BA:34:56:78:9A:33	Set	Delete
		Set	Delete

Active List: This section contains a table with two columns: 'IP Address' and 'MAC Address'. Each row has a 'Lock' button to its right. The entries are as follows:

IP Address	MAC Address	Lock
192.168.128.101	12:34:56:78:9A:BC	Lock
192.168.128.102	12:34:56:78:9A:CD	Lock
192.168.128.108	12:34:56:78:9A:88	Lock

Fig. 6.5.5.7 Static DHCP screen

Set IP Address and MAC address manually

- Step1: Enter the target IP address in a textbox of Setting List which located on the upper part of this screen. IP address is period-separated numbers.
- Step2: Enter the MAC address of the device you want to set. MAC address is colon-separated numbers and alphabets.
- Step3: Click Set button.

Set IP Address and MAC address from Active List

- Step1: Active List which located on the lower part of this screen lists the combination of MAC address and its IP address being allocated by DHCP. Select a combination you want to set from the list.
- Step2: To fix the setting, click Lock button lying on the right side of the combination. (The Lock button is inactivated when the combination has been listed on Setting List already.)
- Step3: The Lock button will be inactivated and the combination will be listed on the Setting List.

6. Web Menu System

Delete a setting

Step1: Select a combination you want to delete from the Setting List (upper list).

Step2: Click “Delete” button for the combination.

Step3: The combination is deleted from the Setting List (upper list) and the lock button of Active List (lower list) is activated when the device was connected to JUE-501/JUE-251.

6.5.5.8 Set Routing Table (Routing Table Screen)

To enter the Routing Table screen, open “Network” menu on the left [menu] panel and select “Routing Table”.

On this screen, user can edit routing table. Routing table is a data table that lists the routes to particular network destinations.

A maximum of 20 routing table can be set.



ID	Target IP	Subnet Mask	Gateway IP	Set/Del
1	<input type="text"/>	255.255.255.0/24	<input type="text"/>	SET DEL
2	<input type="text"/>	255.255.255.0/24	<input type="text"/>	SET DEL
3	<input type="text"/>	255.255.255.0/24	<input type="text"/>	SET DEL
4	<input type="text"/>	255.255.255.0/24	<input type="text"/>	SET DEL

Fig. 6.5.5.8 Routing Table screen

Add new routing

Example) Adding a new routing which passes packet data of 192.168.128.1~192.168.128.15 to 10.20.30.10.

Step1: Enter an IP address which is in your target network to the “Target IP” box. In this case, enter “192.168.128.1”.

Step2: Select subnet mask which represents your target range from the “Subnet Mask” menu. In this case, select “255.255.255.240/28”.

Step3: Enter destination address to the “Gateway IP” box. Enter “10.20.30.10” for this example.

Step4: Click “Set” button.

Delete existing routing

Step1: Click “Del” button in the line you want to delete.

6.5.5.9 Coexistence with Other WAN (WAN Selector Screen)

To enter the WAN Selector screen, open “Network” menu on the left [menu] panel and select “WAN Selector”.

This screen sets auto changeover of WAN system. Once WAN selector is enabled, it checks the subsistence of the Ext (External) WAN by sending ping packets to a host. JUE-501/JUE-251 uses Ext WAN prior to FBB system when Ext WAN was recognized. When the Ext WAN has been disconnected, WAN Selector changes WAN system from the Ext WAN to inmarsat network. It takes about five minutes to change over the WAN system. To enable the WAN Selector function, setting of Ext WAN on Ethernet screen is necessary (refer to [Sec. 6.5.3.3 Set User LAN and Ext WAN (p6-41)]).

NOTE

- There is a possibility to get unexpected communication fee charged because this function sends and receives ping packet through the Ext WAN.
- There is a possibility to get unexpected communication fee charged because inmarsat PS connection remains connected even when WAN Selector selects Ext WAN.
- JRC is indemnified for any communication fee troubles using this function except as outlined in the product warranty and by limitation of law.
- Distribution partner of SIM card might charge a communication fee by only connecting and disconnecting Connection.
- JUE-501/JUE-251 temporarily falls into a state which cannot connect to the internet when it changes WAN system from Ext WAN to Inmarsat network.
- WAN filter is not adapted when the Ext WAN is being selected.

Fig. 6.5.5.8 WAN Selector screen

Table 6.5.5.8 Contents of WAN Selector screen

Display	Contents
1)	WAN Selector
3)	Ping Destination
4)	Gateway IP
2), 5)	Set

6.5.6 Disconnect Automatically by Time (Auto Disconnect Screen)

To enter the Auto Disconnect screen, select “Auto Disconnect” from the left [menu] panel.

Auto disconnection time (Max Time / Idle Time) can be set on this screen. This function prevents users from forgetting disconnection accidentally and from getting unexpected communication charge.

Time unit is minute and the range is 1-240min. Select “Disable” when unlimited connection is required.

The screenshot shows the 'Auto Disconnect' configuration screen. It features a table with two columns: 'Service' and 'Time'. The 'Service' column lists various services: Handset, TEL1, TEL2, TEL3, TEL4, TEL5, TEL6, ISDN, Streaming, and Standard. The 'Time' column shows a dropdown menu set to 'Disable' and a text input field followed by 'min'. A 'Set' button is located at the bottom right of the table.

Service	Time
Handset	Disable min
TEL1	Disable min
TEL2	Disable min
TEL3	Disable min
TEL4	Disable min
TEL5	Disable min
TEL6	Disable min
ISDN	Disable min
Streaming	Disable min
Standard	Disable min

Fig. 6.5.6 Auto Disconnect screen

Setting Auto Disconnect function

Step1: Select “Enable” for the port or service you want to set Auto Disconnect. In the case of Standard IP service, a condition for disconnection is selected.

Step2: Input the maximum time for the connection. The time unit is minute and the range is 1-240min. Terminal will automatically disconnect the communications according to the set time with regardless of its communication state.

Step3: Click “Set” button and register the settings.

NOTE

- Distribution partner of SIM card might charge a communication fee by only connecting and disconnecting Standard IP Connection.
- Auto Disconnect function never disconnects PS Connection connected by Always Activate function. Thus PS Connection connected by Always Activate function keeps the connection active.
- TEL3~6 is not available when Junction board is not connected.

6.5.7 Configure SIM (SIM Screen)

To enter the SIM screen, select “SIM” from the left [menu] panel.

On this screen, the SIM Configuration can be executed.

SIM Config

PIN Remaining Status

1) PIN Remaining 3 times

PIN Mode

2) Select Status Enable (dropdown) 4) Change Status (button)

3) Input PIN (text box)

Change PIN

5) Input Old PIN (text box)

6) Input New PIN (text box)

7) Retype New PIN (text box) 8) Change PIN (button)

Facility Lock

Change Status

9) Network Enable (dropdown) (text box) Change Status (button)

10) Network Subset Disable (dropdown) (text box) Change Status (button)

11) Service Provider Disable (dropdown) (text box) 13) Change Status (button) 14)

12) Corporate Disable (dropdown) (text box) Change Status (button)

Change PIN

15) Select Type Network (dropdown)

16) Input Old PIN (text box)

17) Input New PIN (text box)

18) Retype New PIN (text box) 19) Change PIN (button)

Secondary SIM

20) Disable (dropdown) 21) Set (button)

Fig. 6.5.7 SIM Configuration screen

Table 6.5.7 Contents of SIM Configuration screen

PIN Remaining Status		Contents
1)	PIN Remaining (PUK Remaining)	Remaining number before SIM Lock. When the PIN Remaining number becomes 0, the display changes into PUK Remaining and the communication through the FBB system becomes unavailable (PIN lock). In this case, a recovery by inputting PUK is needed. Type the PUK in 5) Input SIM PUK box and set new PIN code. PUK is described on SIM card holder.
PIN Mode		Contents
2)	Select Status	Enable/Disable PIN Mode If it was enabled, JUE-501/JUE-251 requires PIN input when it was turned on.

6. Web Menu System

3)	Input PIN	To change PIN Mode, PIN input is required.
4)	Change Status	Changes PIN Mode
Change PIN		Contents
5)	Input Old PIN (Input SIM PUK)	Input 4-digits old PIN (Input PUK when the PIN was locked.)
6)	Input New PIN	Input new PIN. The new PIN must be 4-digits number.
7)	Retype New PIN	Retype new PIN for confirmation. Do not use copy and paste.
8)	Change PIN	Register new PIN. If the value of old PIN (or the PUK) was wrong, the SIM page is reloaded with “PIN (or PUK) Remaining” subtracted.
Facility Lock		
Change Status		Contents
9)	Network	Enable locks MCC (Mobile Country Code) and MNC (Mobile Network Code).
10)	Network Subset	Enable locks Network Subset Code.
11)	Service Provider	Enable locks Service Provider Code.
12)	Corporate	Enable locks Corporate Code.
13)	PIN Code input box	There are no initial PIN Codes. The number (from 8 to 16 digits) which is input for the first time shall be applied as the facility PIN Code. If forgot the facility PIN Code, changing the status and changing the PIN Code will be disabled. Please do not forget the facility PIN Codes.
14)	Change Status	Changes status. To change status, password is required. Input the password to the 13) text box located on the left side of “Change Status” button.
Change PIN		Contents
15)	Select Type	Target to change PIN Network/Network Subset/Service Provider/Corporate
16)	Input Old PIN	Input from 8 to 16 digits old PIN
17)	Input New PIN	Input new PIN. The new PIN must be from 8 to 16 digits number.
18)	Retype New PIN	Retype new PIN for confirmation. Do not use copy and paste.
19)	Change PIN	Register new Facility PIN.
Secondary SIM		Contents
20)	Secondary SIM	Use or non-use of Secondary SIM System reboot is required to apply this setting.
21)	Set	Registers the setting.

NOTE

- Communications on FBB system might be disabled by changing SIM Configurations.
- We strongly recommend you to change PIN codes for the security reason.

6.5.8 File Export/Import (Export / Import Screen)

To enter the Export/Import screen, select “Export/Import” from the left [menu] panel.

On this screen, the setting data of each menu can be saved to your PC by clicking “Export” button. Use this function to make a backup file of your settings.

Also, exported data mentioned above can be imported. System reboot is required to install the imported settings.

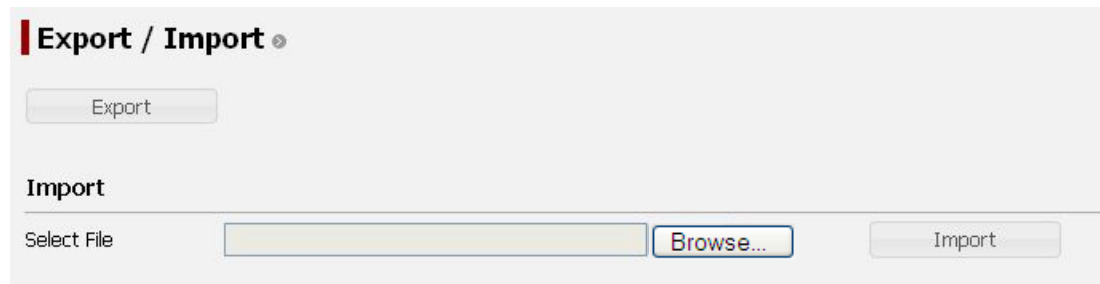

Fig. 6.5.8 Export/Import screen

NOTE

- * Beware that once the data is imported, it won't be recovered again.
- * All the settings will return to factory default when the imported data did not meet the expected format.

6.5.9 Reset to Factory Default (Factory Default Screen)

To enter the Factory Default screen, select “Factory Default” from the left [menu] panel.

On this screen, user can delete Alarmpack or reset all the settings to factory default. System reboots automatically when all flash settings are reset to factory default.



Fig. 6.5.9 Factory Default screen

NOTE

Beware that once the data is reset to the factory default, it won't be recovered again.

6.5.10 Update Software (Software Update Screen)

To enter the Software Update screen, select “Software Update” from the left [menu] panel.

User can update the software of JUE-501/JUE-251 easily. The practical procedure of software updating is described in [Appendix D] of this manual.

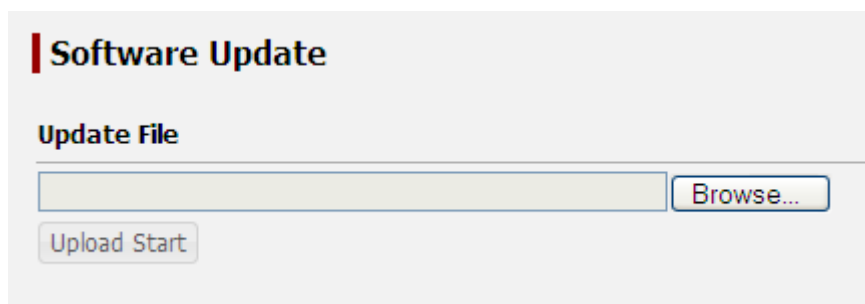

Fig. 6.5.10 Software Update screen

6.5.11 Perform Diagnostic Test (Diagnostic Screen)

To enter the Diagnostic screen, select “Diagnostic” from the left [menu] panel.

User can stack the syslog messages of JUE-501/JUE251 to user-specified server. A syslog server application which can receive syslog protocol (no.514 UDP port) needs to be activated on the specified server. The level of stacking data is defined by user. Syslog messages with upper level predefined by user will be stacked.

User can also confirm whether the line being allocated to JUE-501/JUE-251 is active or not by sending ping packet from selected global IP address to specified internet host.

Destination for Ping packet is specified internet IP address or domain name.

NOTE

- Please do not display any other page or shut down your Web browser, while the ping result is being reported on the page.
- The service type to send ping packet is depending on the source IP address.
- There is a possibility to get unexpected communication fee charged by sending and receiving ping packet.
- JRC is indemnified for any communication fee troubles using this function except as outlined in the product warranty and by limitation of law.

Diagnostic

Syslog Setting

Enable/Disable: Disable (dropdown) | Syslog Server IP: [] | Log Level: ERR (dropdown) | Set: [Set]

File: [File]

Ping

Source: 161.30.23.2 (dropdown) | Destination: [] | Packet Length: 32 | Total Transmissions: 4

[Start] [Stop]

[]

DNS

Local IP	Global IP	Primary DNS	Secondary DNS
192.168.128.180	161.30.23.2	172.30.194.8	172.30.194.11

Fig. 6.5.11 Diagnostic screen

6. Web Menu System

This page is remained as a blank.

7. Handset Menu System

Menus can be displayed and operated with Handset are as follows.

Table. 7. Contents of Handset menu

Chapter No/Name of screen	Contents
-TOP menu	Displays the list of items of this group.
7.1 Status menu	Displays the list of the items of equipment status.
7.2 SMS menu	Displays, creates, sends, receives, and deletes the SMS.
7.3 Satellite menu	Displays the list of the items of Satellite status.
7.4 Phonebook menu	Displays the Phone Book and originating a call.
7.5 Redial menu	Displays the list of Redial number.
7.6 Internal menu	Displays and calls the Internal Phone.
7.7 Call Log menu	Displays the list of Call Log.
7.8 Alarmpack menu	Displays the list of Alarm Pack Log.
7.9 Admin menu	Displays the list of setting/ browsing items available for Admin user only
7.9.1 Terminal menu	Sets up Delivery date Time difference, Local Time display Tracking type GPS Input VDR Output WRF (Wide-band Radio Frequency) On/ Off of LED Blocking Indicator
7.9.2 Telephony menu (Port Control)	Sets up Use of Secret code of Handset/terminal telephone Voice volume of Handset/terminal telephone Type of terminal telephone (Voice or FAX) Call request/Call reception Auto Answer Voice Mail, Call Forwarding, Call Waiting, Call Barring
7.9.3 Port menu	Sets up (Handset) Backlight of screen/Dimmer of LEDs Pattern/Volume of Ringer tone Volume of Voice tone On/Off of key click sound (ISDN) MSN of Voice/Audio/UDI/RDI/PBX (Ethernet) User LAN; IP address/DHCP function Ext WAN; IP address/Subnet Mask (I/O)Output/Input/Function (Option)use or non use of Button/Buzzer
7.9.4 User Cont. (User Registration)	Sets up Users with secret code and usage restriction Usage Restriction group
7.9.5 Auto Dcn. (Auto Disconnect)	Sets up Maximum connection time of each communication terminal
7.9.6 SIM menu	Sets up Communication mode using SIM card
7.9.7 Default menu	Sets up Reset to Factory Default

Accessible for
All user

Accessible for
Admin
user Only

7. Handset Menu System

(This screen is popped up in all menu)

7.10 Other screen (TX alarm screen)	Alarm message is popped up when a failure is occurred in transmission system.
--	---

TOP menu

To open TOP menu, just push MENU button

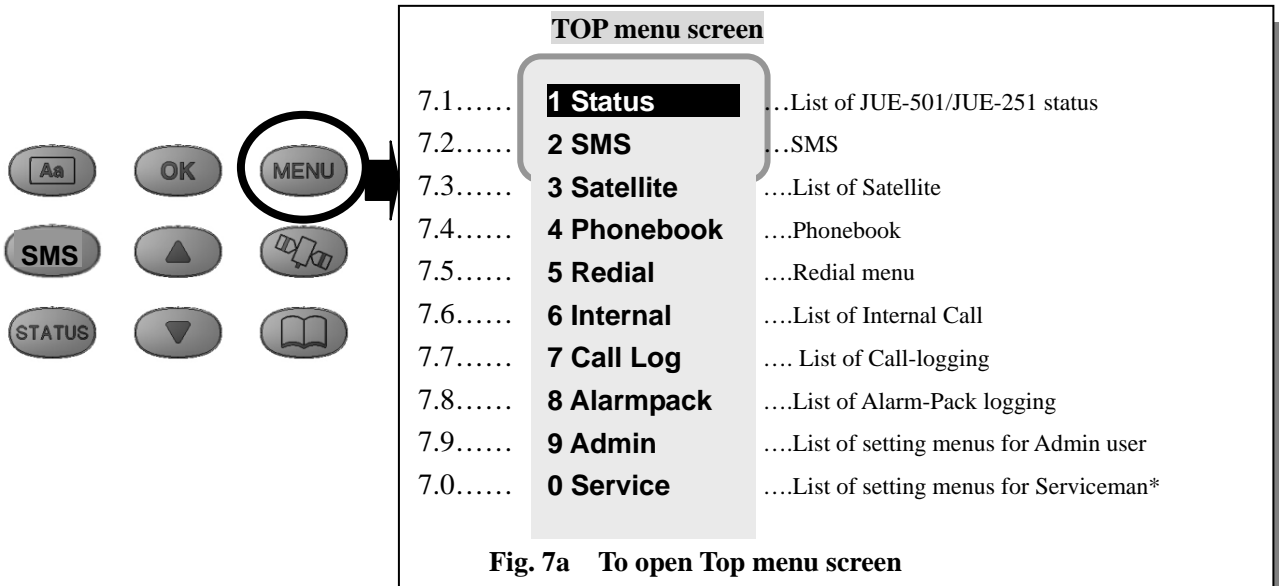

Note*) [0 Service] is the menu for serviceman only, ordinary user cannot log-in although TOP menu screen displays this menu all the time.

Direct button makes quick access to each menu

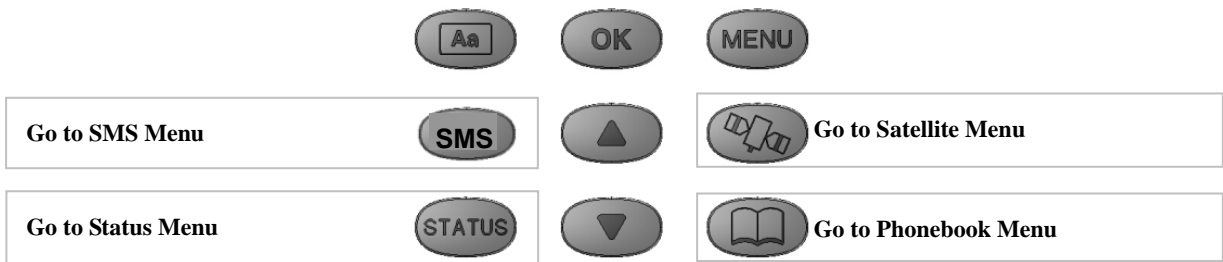

Fig. 7b Direct buttons

■ **Short cut function also makes quick access to each menu**

(Available for almost all of the screens)

Press **MENU** button and the number of each item, then you can display desired screen directly.

Example) To display [Delivery setting value screen], press **MENU** + **1** + **4** + **3**

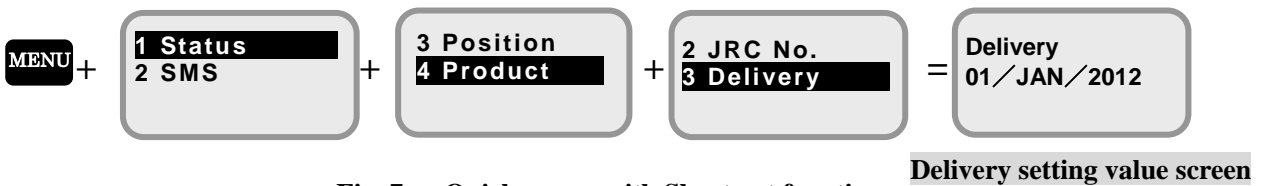

Fig. 7c Quick access with Short cut function

■ Press **CLR** button to return to the previous screen.

■ Press **Phone** button to return to Idle screen instantly.

In this section, menus for all users are described.

7.1 Status menu

(Short cut is **MENU+1**)

In this menu, user can display the status of the JUE-501/JUE-251, receiving/transmitting status, latitude/longitude of the ship and the version of each device.

The figure shown below is the whole flow chart of this menu. Each item is selectable.

Press **OK** button to fix. To return to Top menu, press **CLR** button several times.

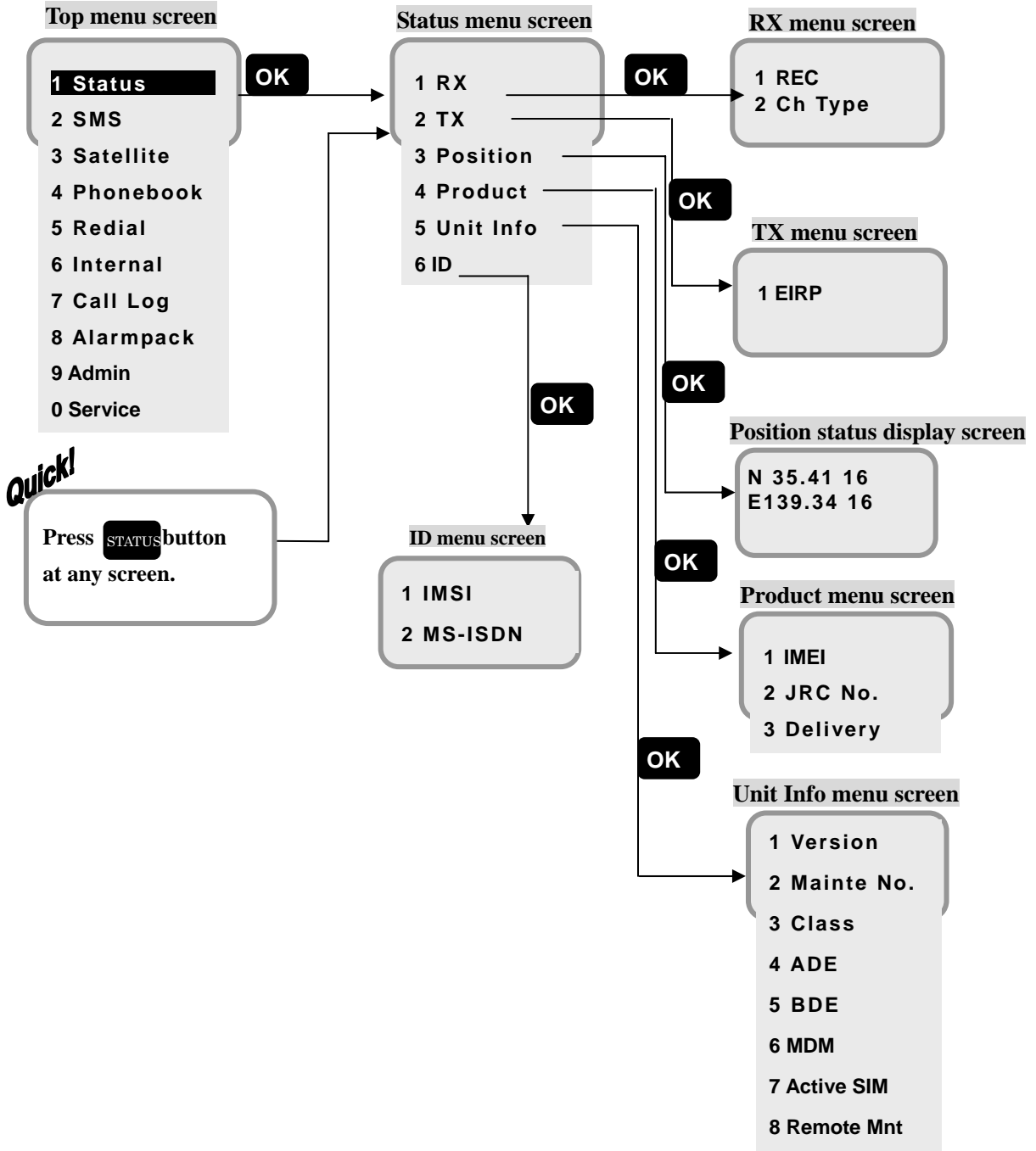
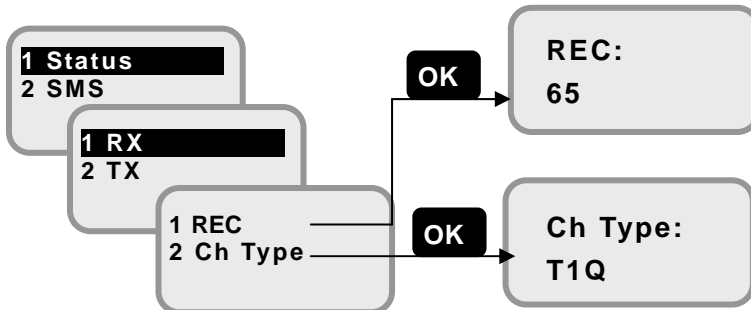

Fig. 7.1 Configuration of Status menu

7.1.1 RX(Reception) menu**(MENU+1+1+1 to 2)**

In this menu, user can display the Reception level (REC), and Channel type (CH TYPE).

**REC level display screen**

RECEIVING level is displayed in number value.
Communication is not available when low value is displayed.

Ch Type setting value display screen

Channel type is displayed from T025Q, T1Q, T1X, and T45X.

Fig. 7.1.1 RX(Reception) Menu**7.1.2 TX(Transmission) menu****(MENU+1+2+1)**

In this menu, user can display the Transmission level (EIRP).

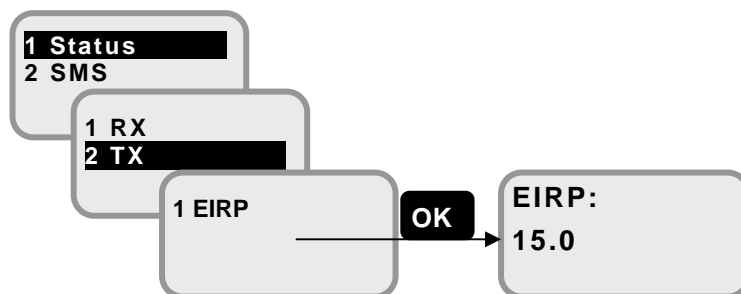
**EIRP display screen**

EIRP (Transmission level) is displayed in number.

Fig. 7.1.2 TX(Transmission) menu

7.1.3 Position status display

(**MENU**+ **1**+**3**)

In this menu, user can display the latitude and longitude of ship's position.

N stands for North latitude, S for South latitude, E for East longitude, and W for West longitude.

N and S are displayed in upper line, and E and W in the lower.

Status of GPS positioning consists of the four terms listed below.

Table 7.1.3 Position acquisition status of GPS

1 Cold Start	The position is not fixed yet.	↑ Unfix status
2 Unfix		
3 2-D Fix (2 dimensional positioning)	The position has been fixed by three satellites, but altitude is not.	↓ Fix status
4 3-D Fix (3 dimensional positioning)		

Unfix screen is displayed when GPS status is Cold Start or Unfix.

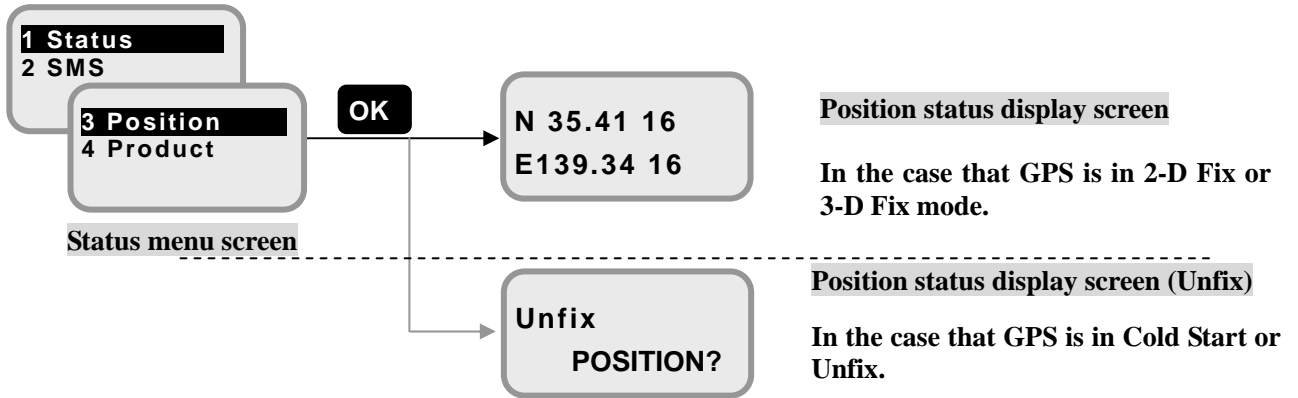

Fig. 7.1.3a Position status display screens

7.1.4 Product menu

(MENU+ 1 +4 +1 to 3)

In this menu, user can display the IMEI (International Mobile Equipment Identity), JRC No (manufacturer's serial No.), and Delivery date of the JUE-501/JUE-251.

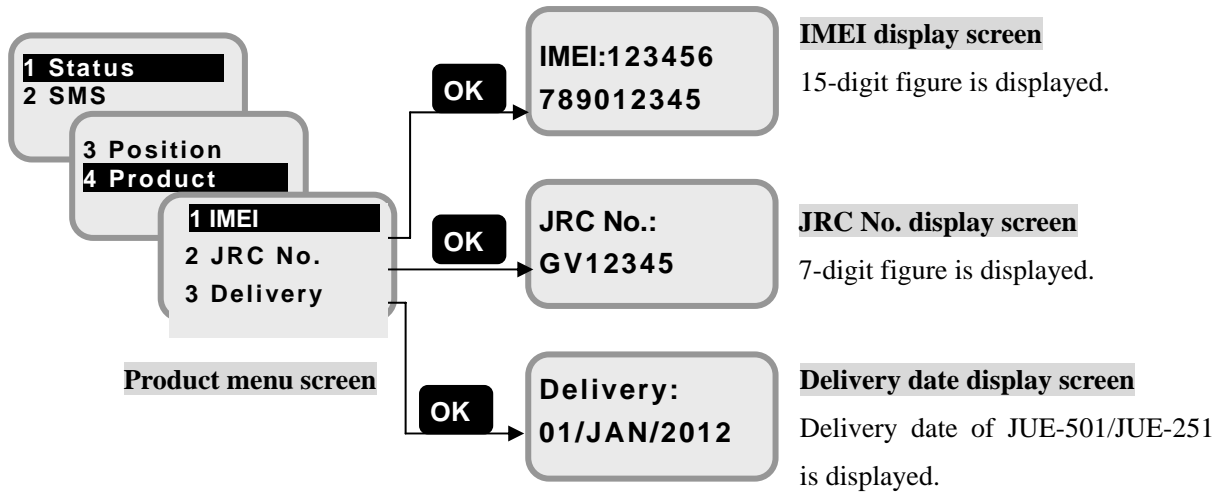

Fig. 7.1.4 Product menu status display screens

7.1.5 Unit Info menu

(**MENU**+**1**+**5**+**1** to **4**)

In this menu, user can display the software version, maintenance No. and status of ADE/BDE.

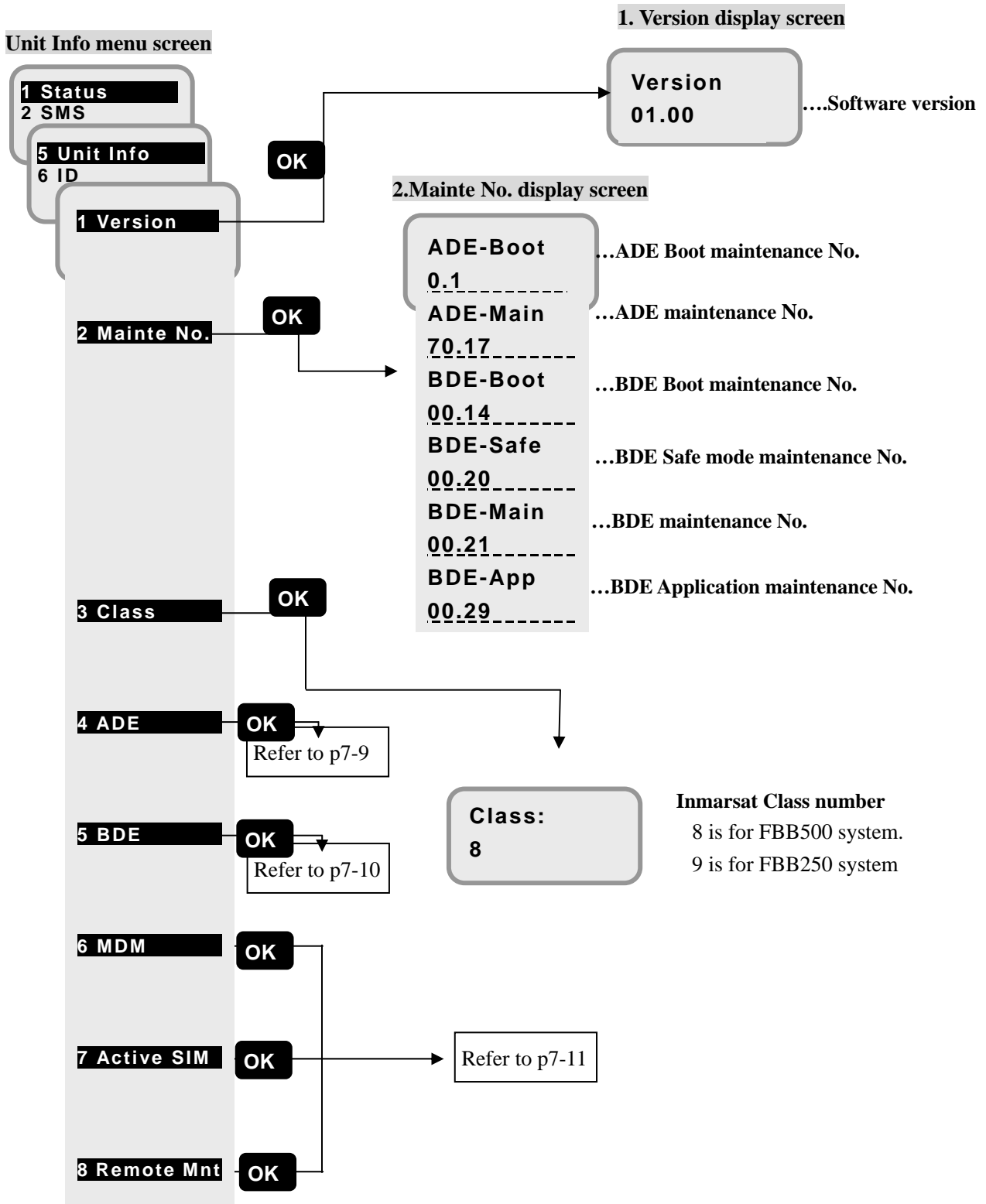

Fig. 8.1.5a Each status display screen of Unit Info (1/4)

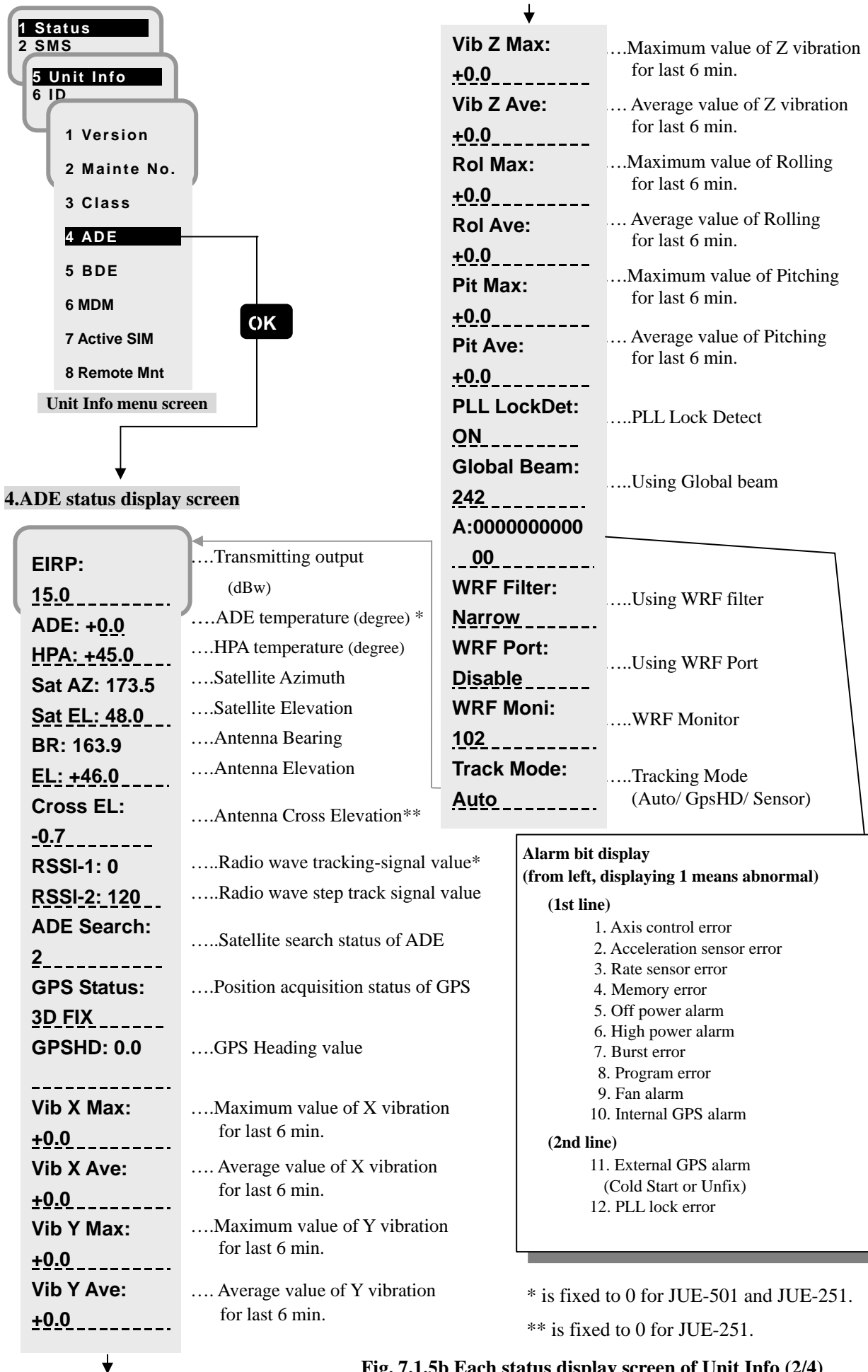

Fig. 7.1.5b Each status display screen of Unit Info (2/4)

7. Handset Menu System

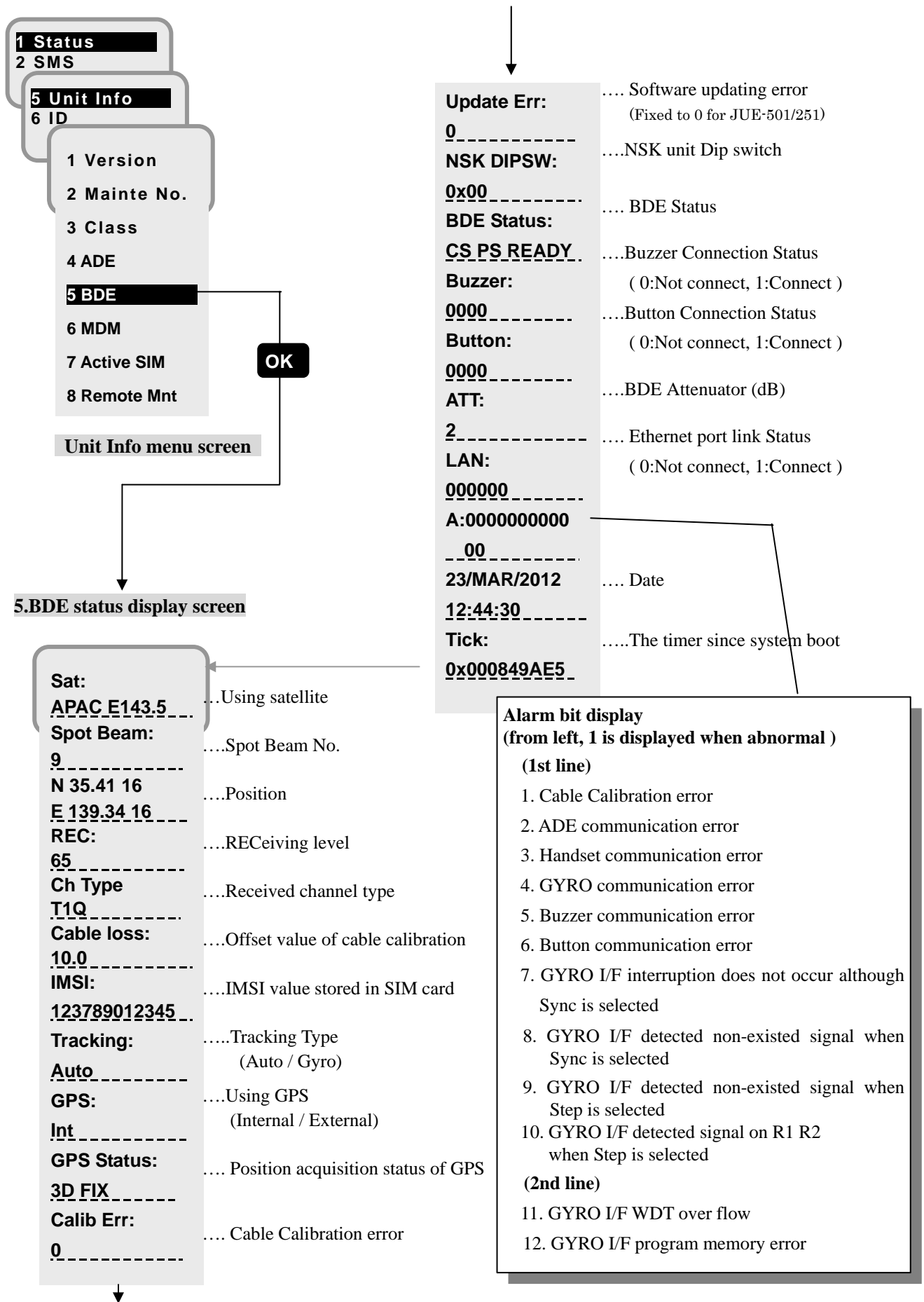

Fig. 7.1.5b Each status display screen of Unit Info (3/4)

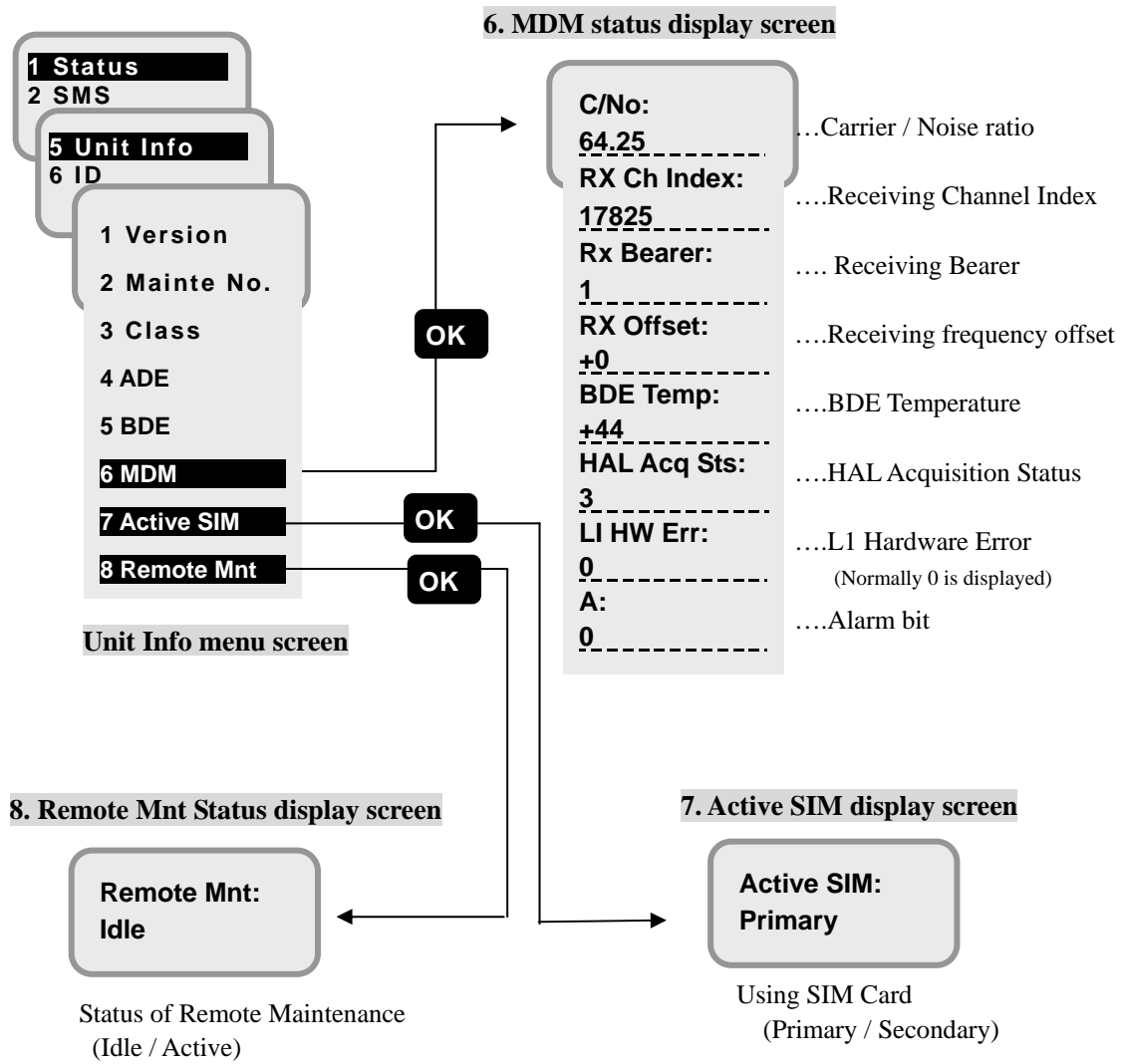
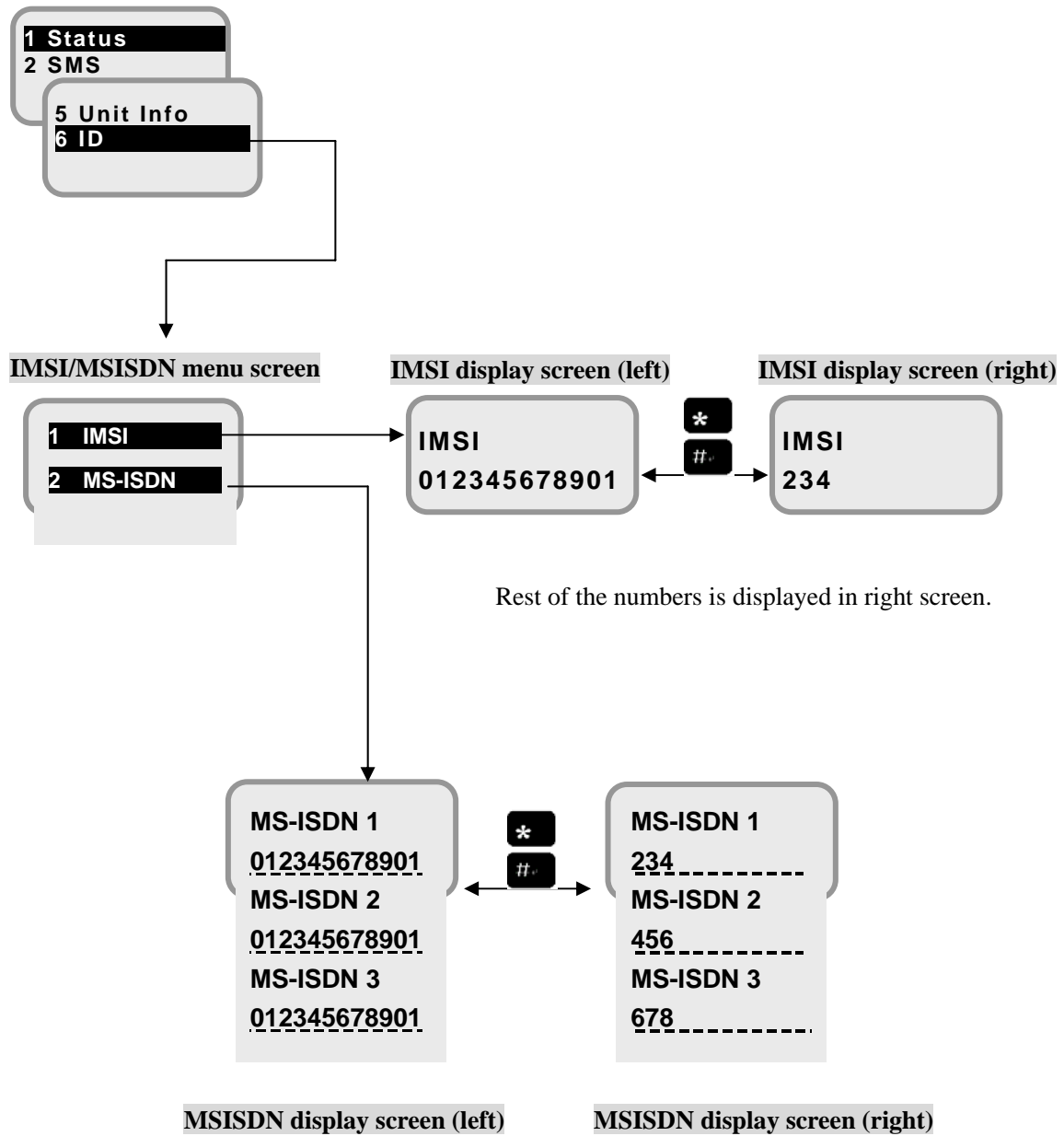

Fig. 7.1.5c Each status display screen of Unit Info(4/4)

7.1.6 ID menu

(**MENU**+**1**+**6**+**1** to **2**)

In this menu, user can display the ID of IMSI/MSISDN.



IMSI (International Mobile Subscriber Identity)

MSISDN (Mobile Subscriber ISDN Number)

Fig. 7.1.6 ID menu status display screens

7.2 SMS menu

(MENU+2)

In this menu, user can read, create, send, and delete SMS.

NOTE

Delete unnecessary message constantly because receiving SMS new message and sending message from Handset are become impossible when the memory usage amount becomes equal to total message capacity.

*Capacity confirmation method: refer to [7.2.5 Setting menu] (p7-20)

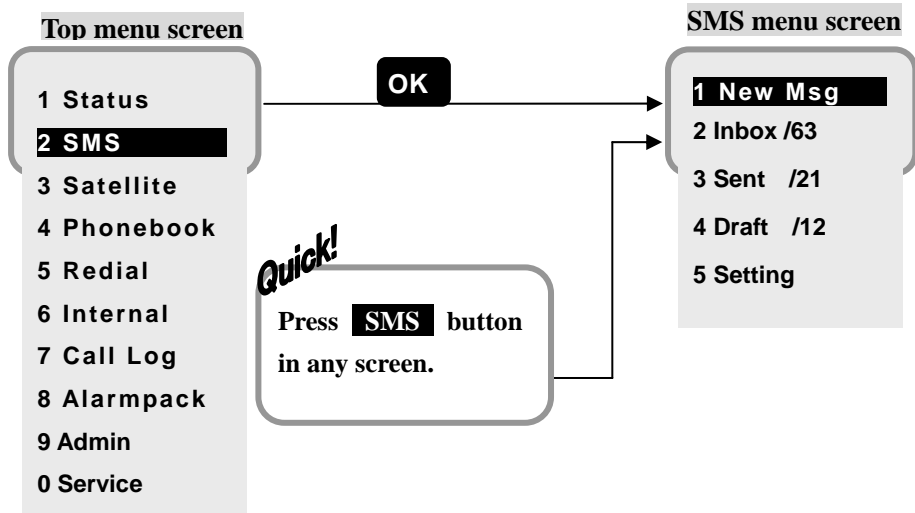

Fig. 7.2a SMS menu screen

How to input the message from Handset

- To toggle the input mode, press **Aa** button.

Input mode is transited within **Aa**(Capital input mode), **aA**(alphabet input mode), and **0** (nothing is displayed, it is numeric mode).

Refer to the next page about the detail of the characters applied by each mode.



Fig. 7.2b To toggle the input mode

- To fix the input character, press **#>** key.

Input character blinks and not fixes until **#>** key is pressed.



Fig. 7.2c To fix the input character

7. Handset Menu System

Capital input mode

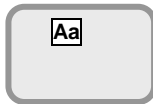

When **Aa** is displayed in [Input mode] area, below characters are being input.

Pushed times	1	2	3	4	5	6	7	8	9	10	11	12	13
(Key) 0	.	,	—	?	!	“	‘	¥	\$	&	:	;	#
1	*1	*2	@	—	()	<	>	%	+	*	/	=
2	A	B	C	a	b	c							
3	D	E	F	d	e	f							
4	G	H	I	g	h	i							
5	J	K	L	j	k	l							
6	M	N	O	m	n	o							
7	P	Q	R	S	p	q	r	s					
8	T	U	V	t	u	v							
9	W	X	Y	Z	w	x	y	z					

Alphabet input mode

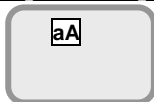

When **aA** is displayed in [Input mode] area, below characters are being input.

Pushed times	1	2	3	4	5	6	7	8	9	10	11	12	13
(Key) 0	.	,	—	?	!	“	‘	¥	\$	&	:	;	#
1	*1	*2	@	—	()	<	>	%	+	*	/	=
2	a	b	c	A	B	C							
3	d	e	f	D	E	F							
4	g	h	i	G	H	I							
5	j	k	l	J	K	L							
6	m	n	o	M	N	O							
7	p	q	r	s	P	Q	R	S					
8	t	u	v	T	U	V							
9	w	x	y	z	W	X	Y	Z					

*1 =space

Press 1 key once, a space is entered in cursor position.

*2 =new line

Press 1 key twice, the linefeed is executed at cursor position.

Numeric mode

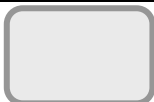

When nothing is displayed in [Input mode] (numeric mode) area, it is numeric mode.

7.2.1 New Msg menu

(MENU+2+1)

In this menu, user can create, send, and save (as unsent) new messages. Unsent messages are saved in the [4. Draft] menu.

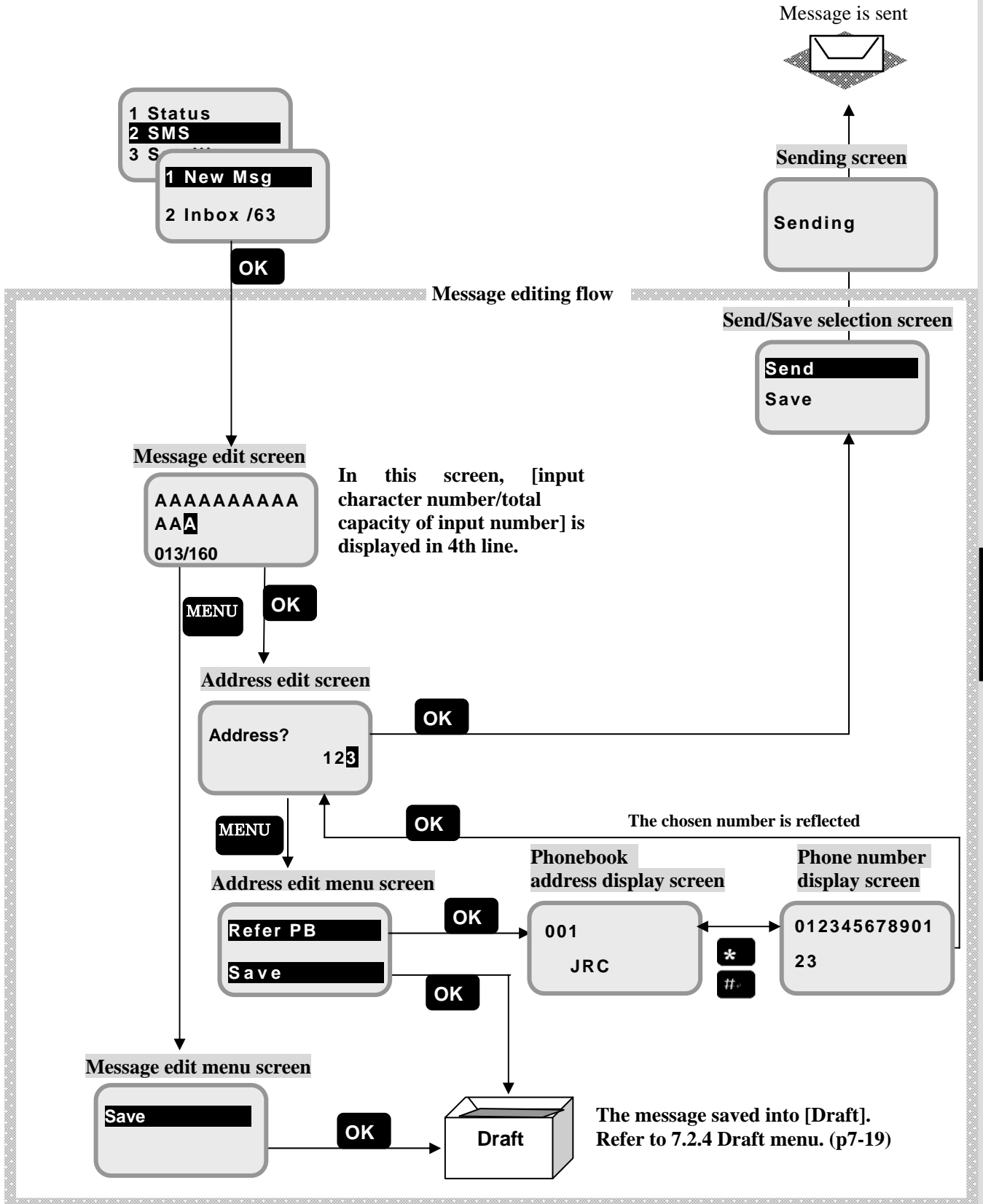

Fig. 7.2.1a New Msg menu

When the sending is succeeded: the sent message is saved in [Sent] of SMS menu

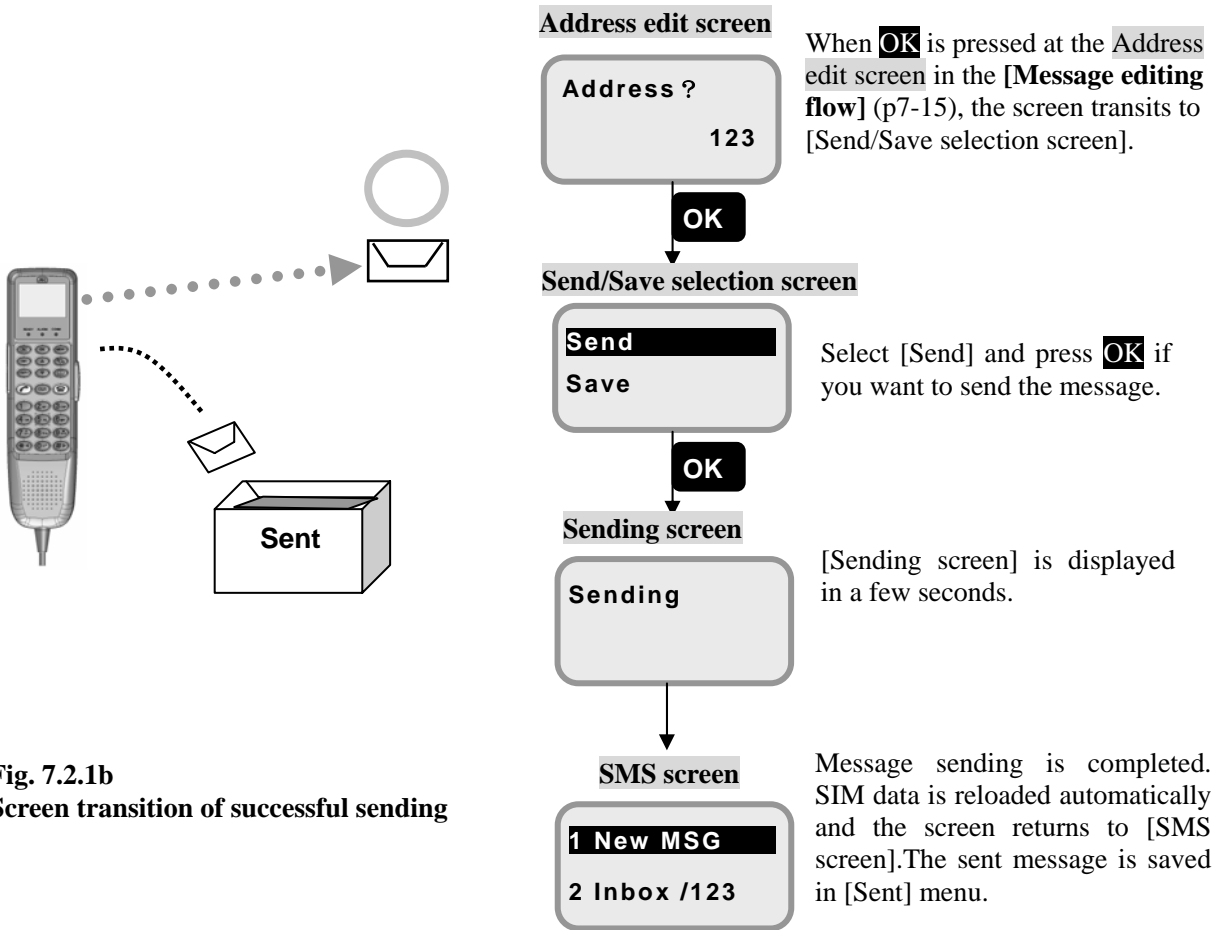

Fig. 7.2.1b
Screen transition of successful sending

When the sending is failed: the sent message is saved in [Draft] of SMS menu

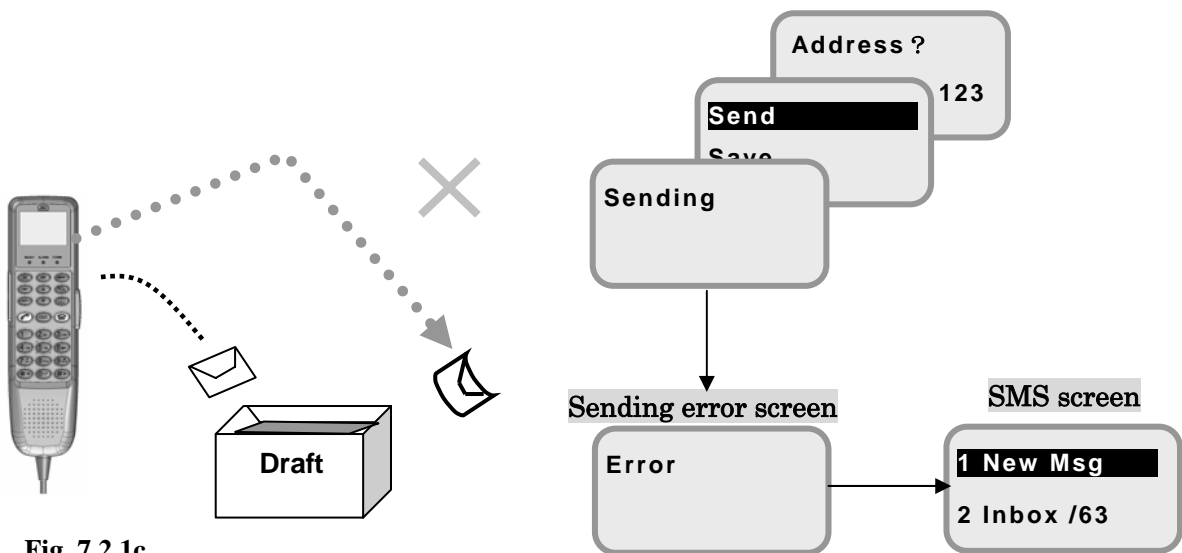

Fig. 7.2.1c
Screen transition of failed sending

When sending message is failed, [Error screen] is displayed.

Follow below procedure to resend the message:

[1. New Msg] **OK**->[Continue?] **Yes**->[Message editing screen] **OK**->[Address editing screen]->[Send]**OK**.

7.2.2 Inbox menu

(MENU+2+2)

In this menu, user can read, reply, forward, and delete the received messages.

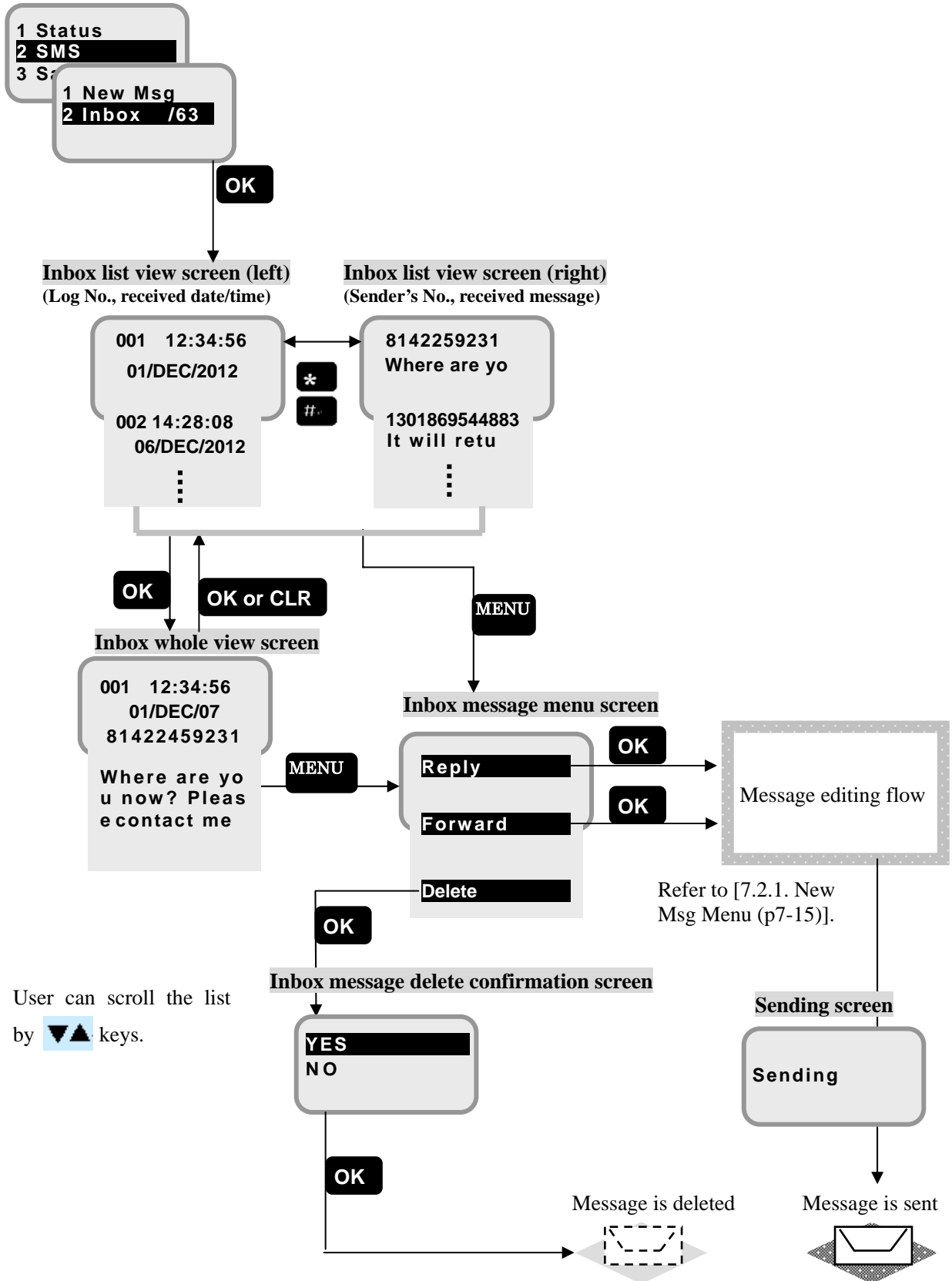

User can scroll the list by keys.

Fig. 7.2.2 Inbox menu

In this menu, user can read, resend, forward, and delete the sent messages.

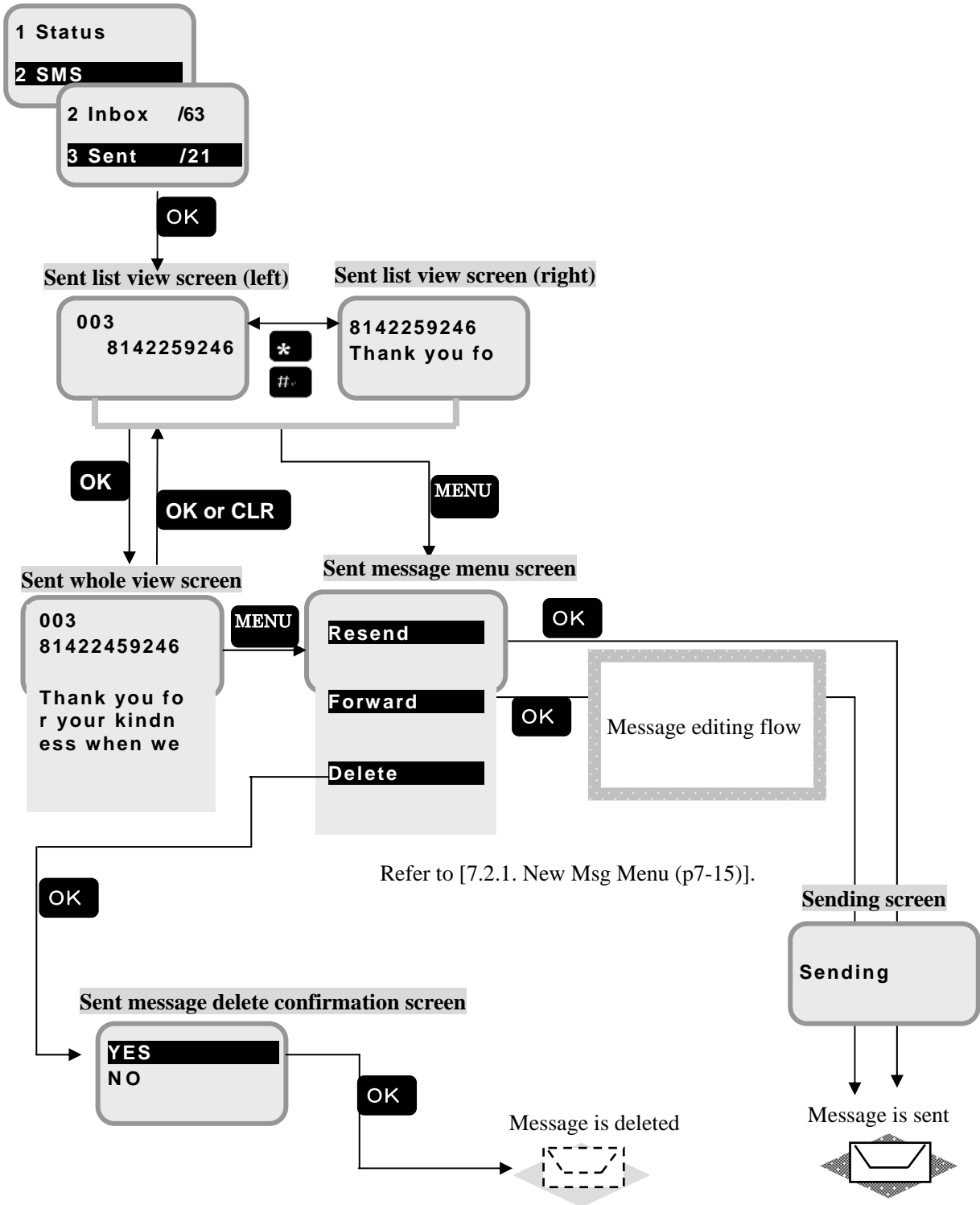

Fig. 7.2.3 Sent menu

7.2.4 Draft menu

(MENU+2+4)

In this menu, user can read, edit, send, and delete the unsent messages.

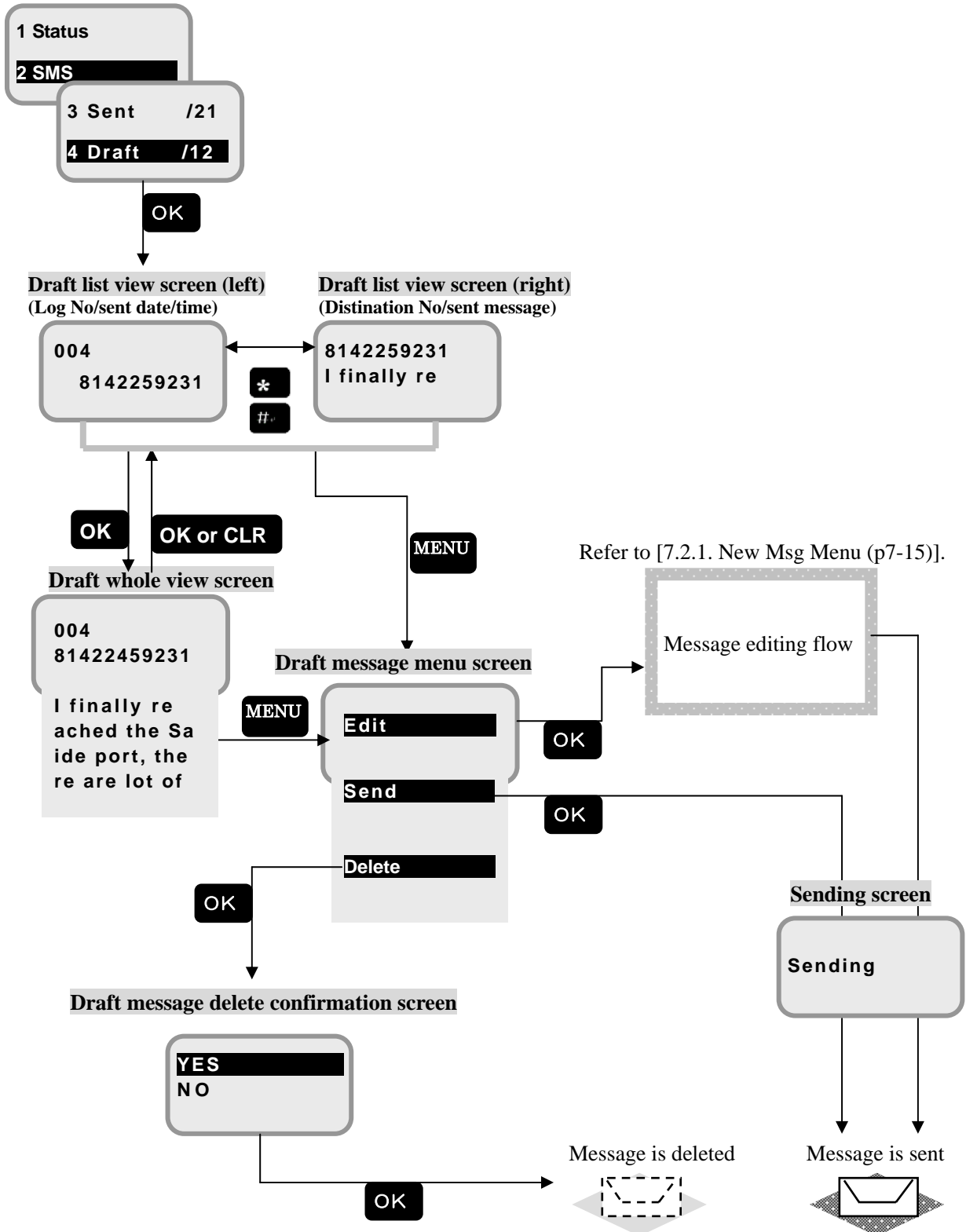

Fig. 7.2.4 Draft menu

7.2.5 Setting menu

(MENU+ 2+ 5)

In this menu, user can read the used amount of mailboxes, delete all messages at once, and set the details of SMS service.

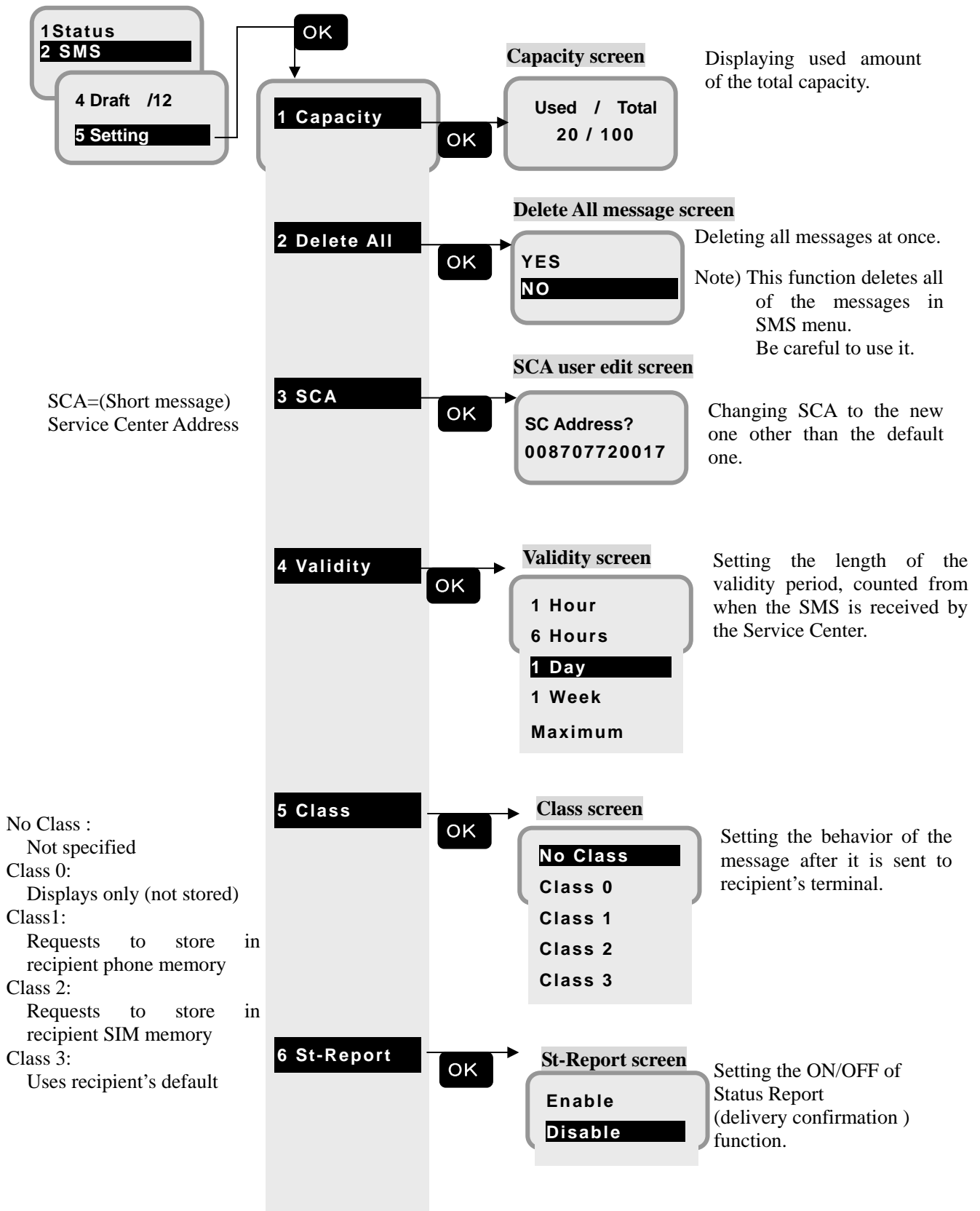

Fig. 7.2.5 Setting menu

7.3 Satellite menu

(MENU+3)

In this menu, user can display the information of satellite including ocean region and spot beam No.

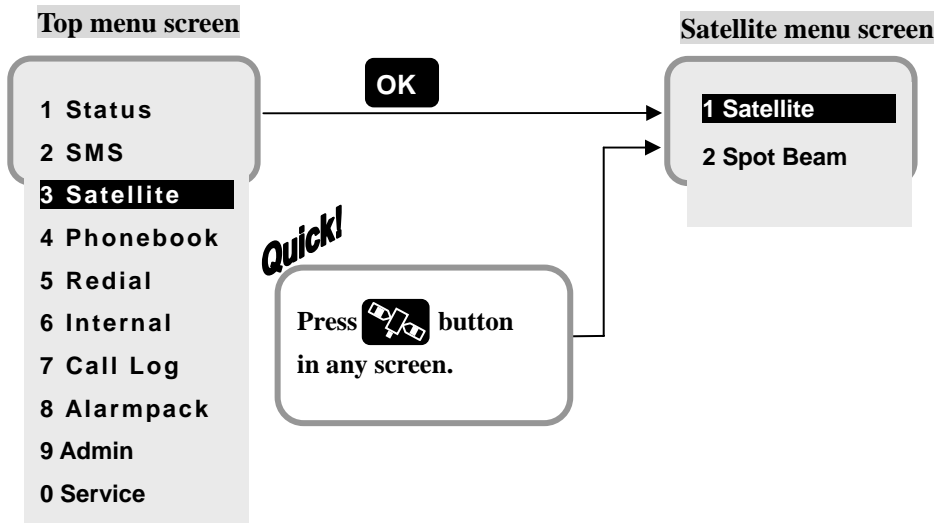

Fig. 7.3 Satellite menu screen

7.3.1 Satellite selection

(MENU+3+1)

In this menu, satellite can be changed. Currently selected satellite is denoted by “*”.

Select the preferred satellite and press **OK** button. The JUE-501/JUE-251 will search the most suitable satellite if “Auto” is chosen.

* Although there is nothing wrong with JUE-501/JUE-251, selecting satellite makes some noise on ADE.

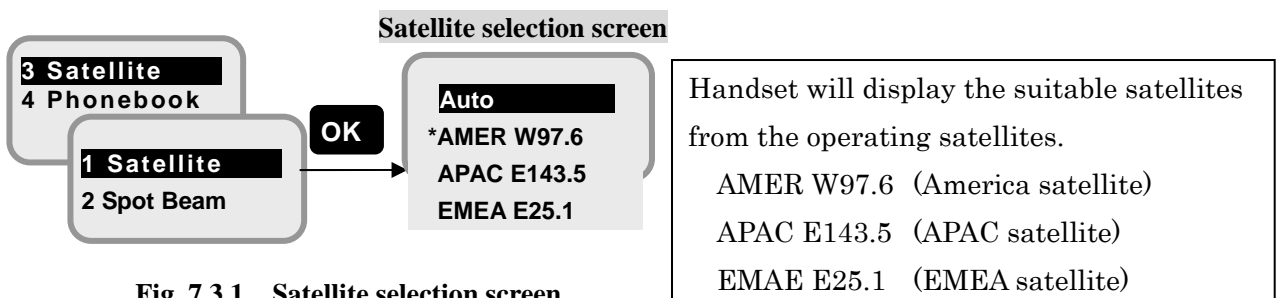

Fig. 7.3.1 Satellite selection screen

7.3.2 Spot Beam ID display

(MENU+3+2)

In this menu, user can display the ID of Spot Beam.

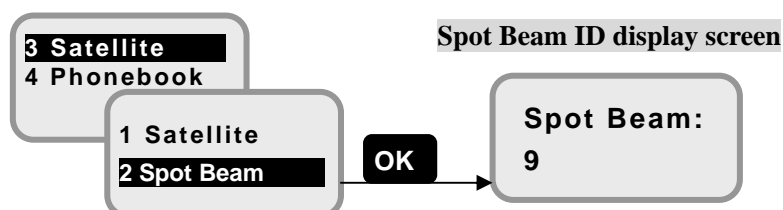

Fig. 7.3.2 Spot Beam ID display screen

7.4 Phonebook (Speed dial) menu

(**MENU**+**4**)

In this menu, the user can display and edit the Phonebook. Refer to [5.1.2 Using Phonebook (Speed dial)] (p5-7) about dial-up procedure. Maximum 200 speed dials can be set.

Press **[Book icon]** button from [Idle screen], or select [4.Phonebook] from Top menu screen, then [Address display screen] is displayed. This screen displays Speed Dial Number and person's name.

Press **[*]** or **[#]** to display the full number. The screen is switched to [Telephone number display screen].

Press **MENU** button with [Address display screen] or [phone number display screen] opened, to register, change, or delete the data. The screen is changed to [Operation selecting screen] (Press **OK** button at this step or off-hook the Handset, to go to [Dial-up screen]). However, Secret Code authentication screen is displayed prior to this screen, when you have not logged-in as Admin user. Enter the secret code to go to [Operation selecting screen]. Press **CLR** key, or On Hook button, to cancel the job and return to the previous screen.

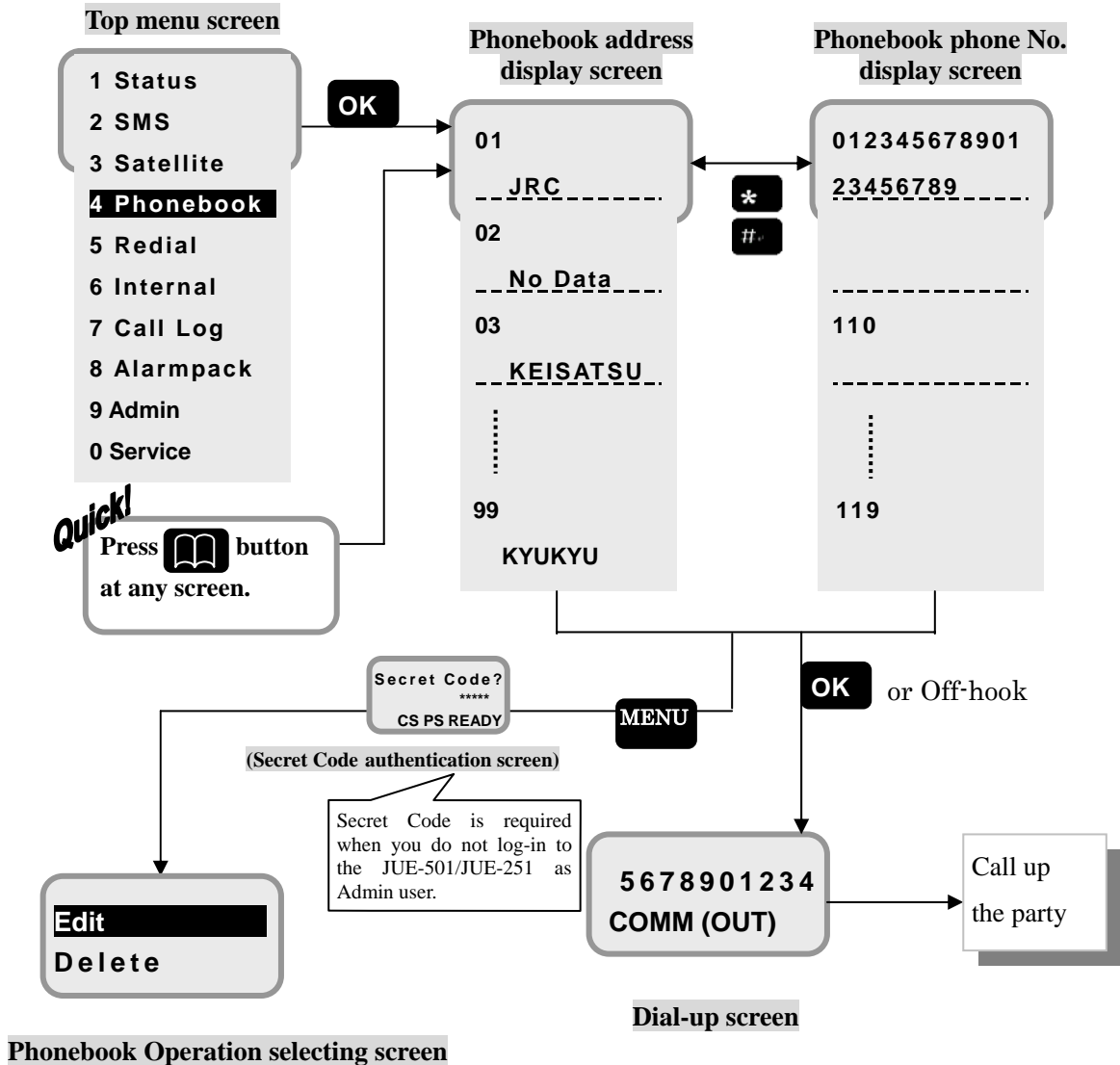

Fig. 7.4 Flow of Phonebook menu

7.4.1 Editing the Phonebook address (**MENU** + **4** + **MENU**)

In this menu, the user can register, change, and delete the address (name of party) and telephone number.

Press **MENU** button with the [Phonebook address display screen] or [Phonebook phone No. display screen] opened, then [Phonebook Operation selecting screen] is displayed.

Select [Edit] and press **OK**, selected party is changed to [Address/Phone number editing screen]. The blinking cursor let you to enter the new address.

Enter the new address and press **OK** then enter the new number with alphanumeric buttons.

If [Delete] is selected, the data is deleted instantly, and the screen is returned to [Address/Telephone number list display screen]. Only [No Data] is indicated for the address.

Example) Editing an existing address/ Phone number (blank address/phone number is displayed when data is filled in newly).

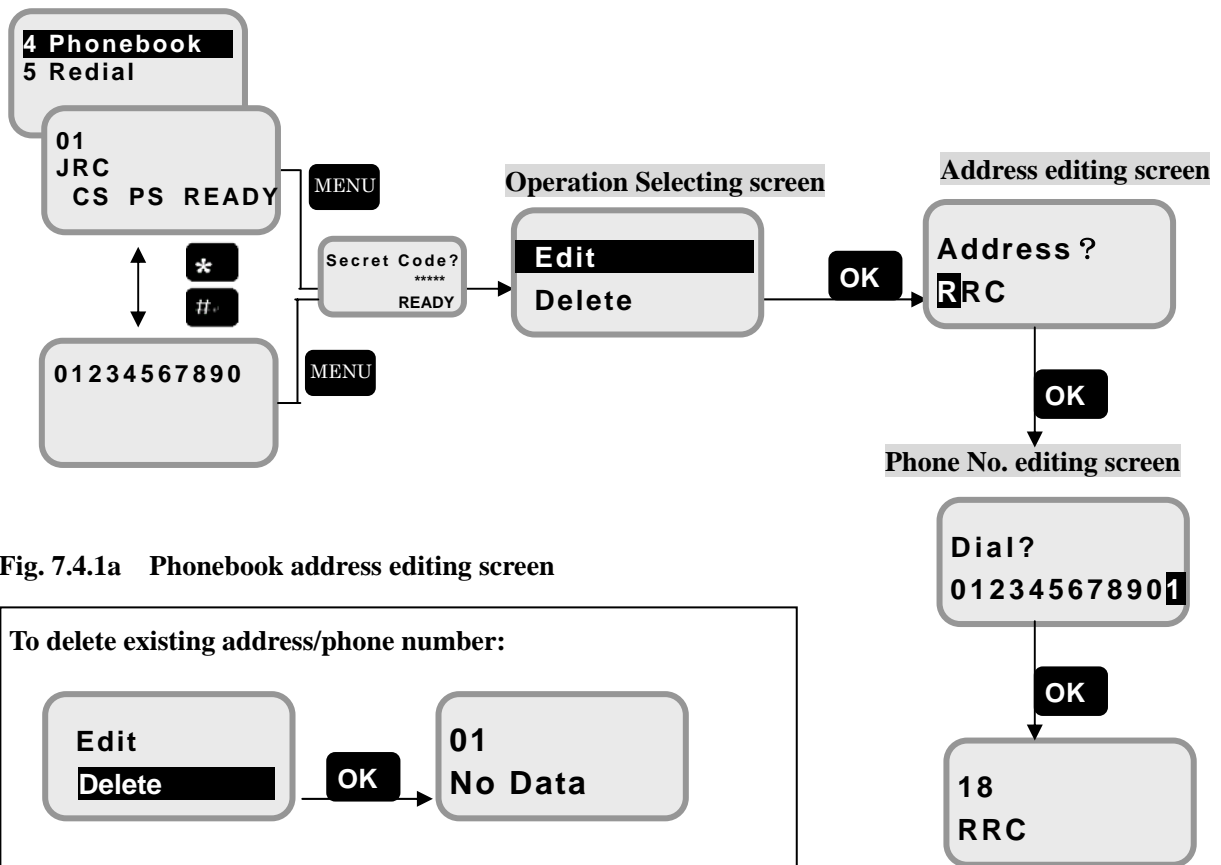

Fig. 7.4.1a Phonebook address editing screen

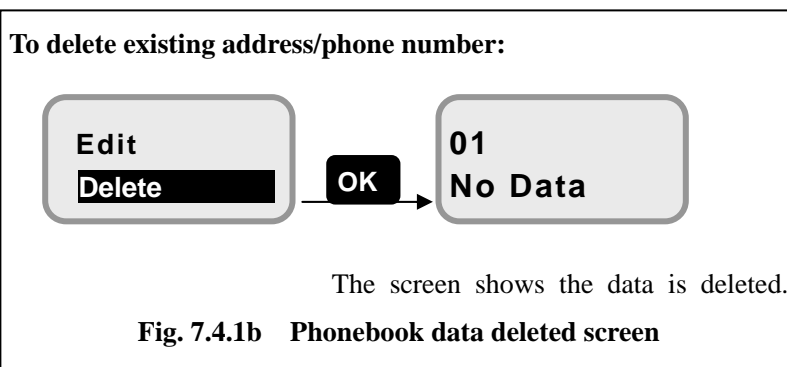

Fig. 7.4.1b Phonebook data deleted screen

Overwritten screen is displayed.

7.5 Redial menu

(MENU+5)

In this menu, the user can display the Redial numbers up to 50.

First, [Redial history list screen] is displayed.

The screen displays Redial history number (01 to 50), and telephone number (if the number is longer than 10-digit, first several digits are not displayed).

To confirm the whole telephone number, press * or # at [Redial history list display screen]. The screen will show the full telephone number with [Redial history detailed display screen].

Scroll the screen with ▼▲ button to display the number dialed before and after.

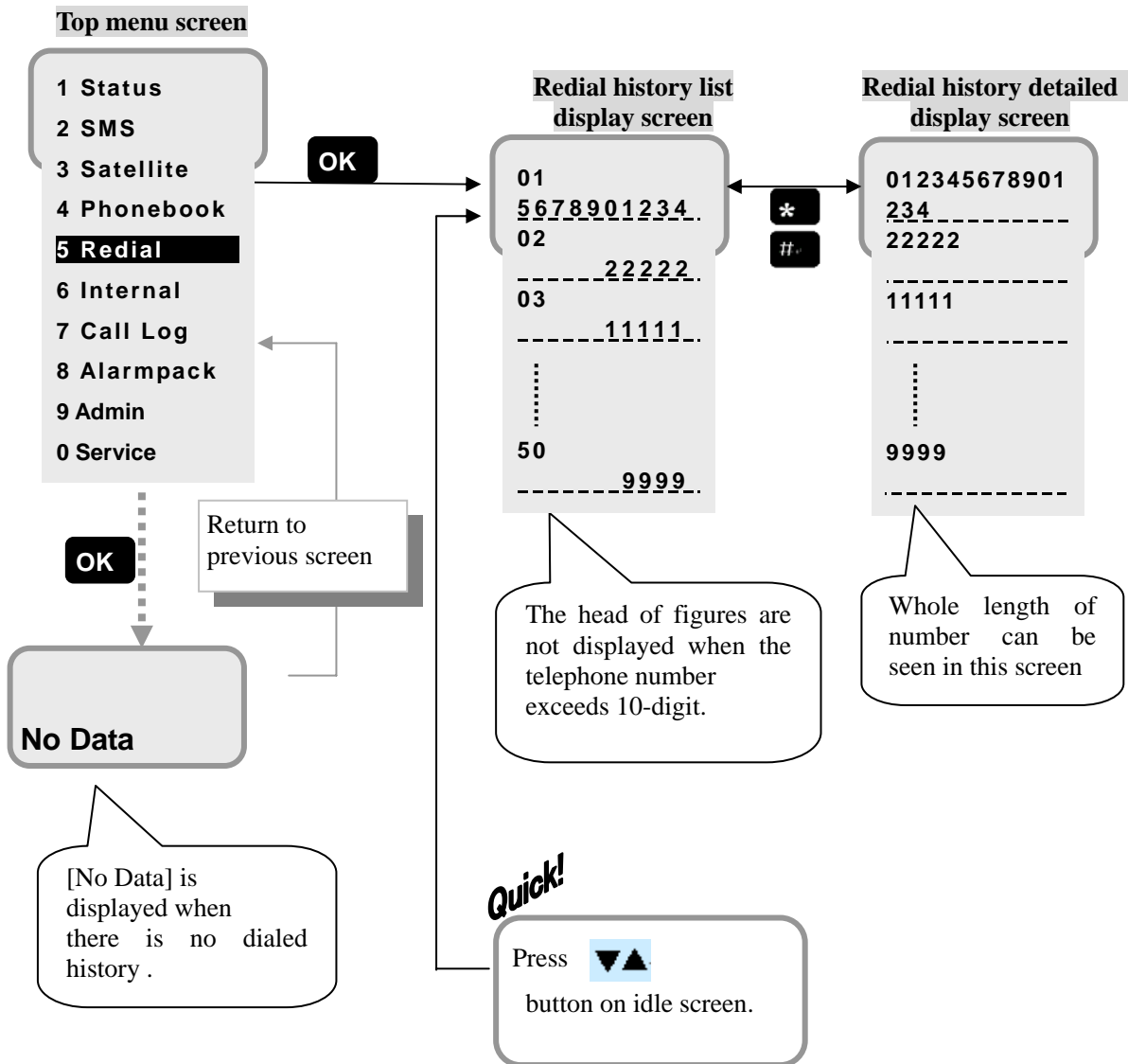



Fig. 7.5 Redial menu screen

7.6 Internal menu

MENU+6+1~3

In this menu, user can call up Internal Phone.

Internal menu is displayed in three service types, TEL, ISDN and All. Select the device you want to call by  button and push **OK**

When TEL is selected, [TEL select menu screen] will be displayed. Select the telephone you want to call and push **OK**, then the extension number of the telephone will be displayed.

When ISDN or All is selected, the extension number will be displayed without [TEL select menu screen].

Push **OK** or off-hook button with the [Extension number screen] opened, and the internal call will be made.

Extension number is allocated following table 7.6.1.

Table 7.6.1 Allocated Extension Number

Device		Allocated number
Handset		000
TEL	TEL1~TEL6	001~006
	All	099
ISDN		401
All		999

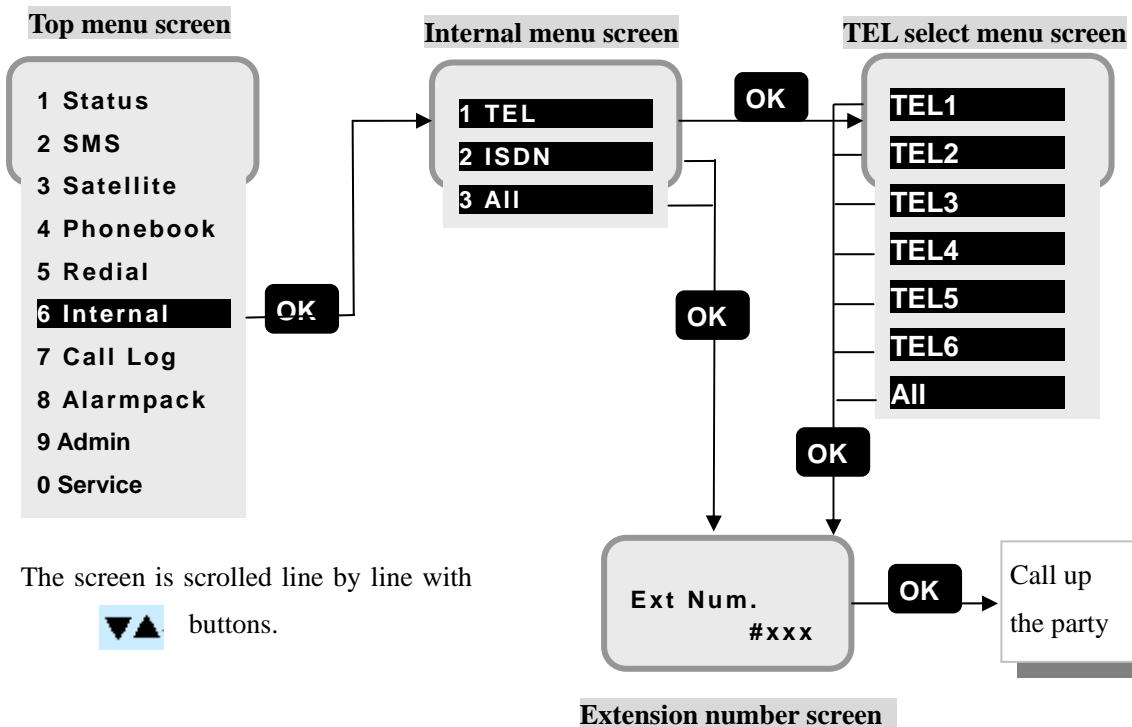

Fig. 7.6 Local Call menu screen

7.7 Call Log (Communication history) menu

MENU+7+1~9

In this menu, user can display the Call Log (Communication history) of respective communication type.

Call Log is displayed in eight service types Voice, Fax, Audio, UDI, RDI, SMS, Standard and Streaming for JUE-501 and six service types Voice, Fax, Audio, SMS, Standard and Streaming for JUE-251. They are divided into three kinds of screens, Both (outgoing and incoming), Out (outgoing only), and In (incoming only).

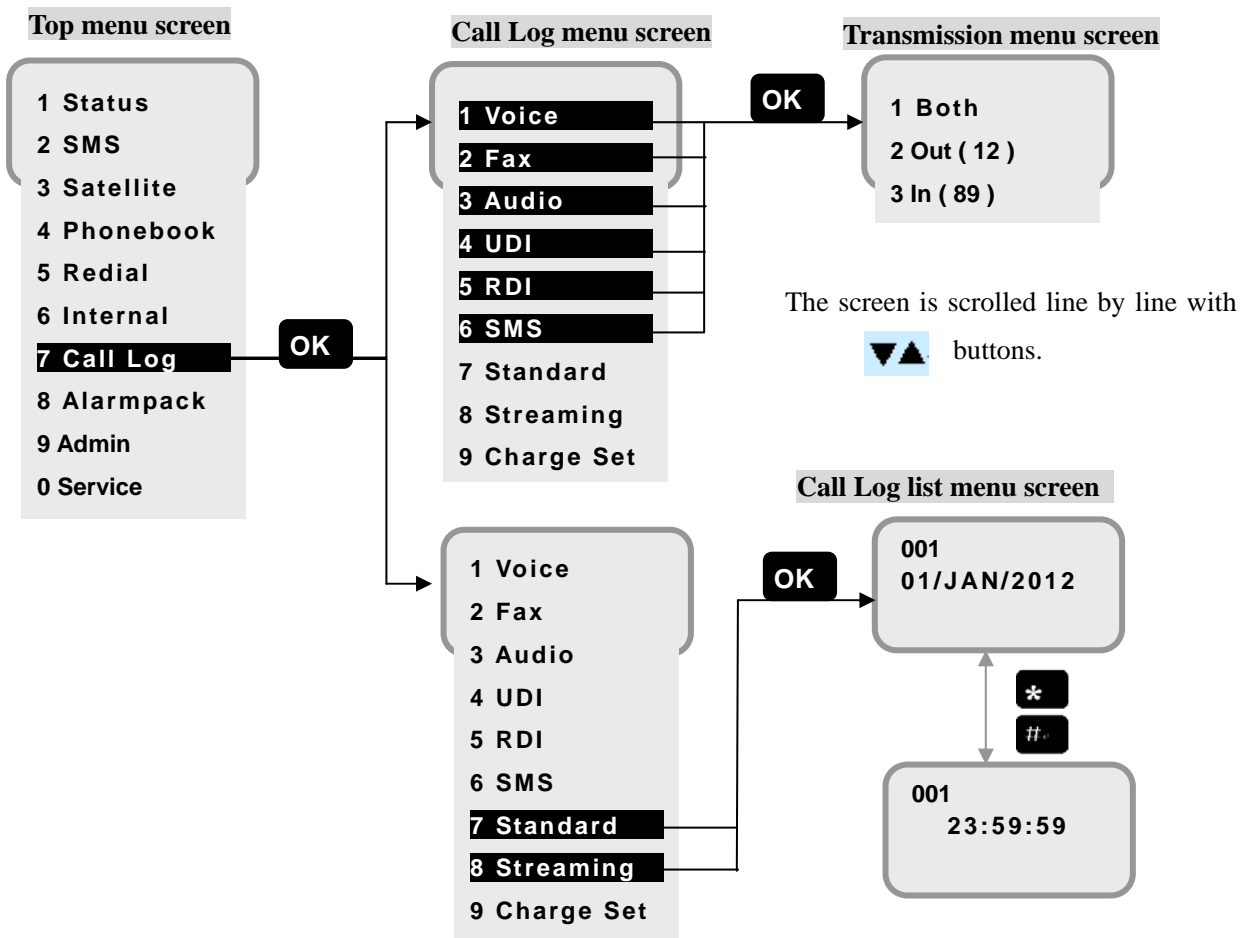

Fig. 7.7 Call Log menu screen (JUE-501)

- * [4 UDI] and [5 RDI] menus are not displayed for JUE-251.
- * [Out] and [In] call log stores maximum 100 data, respectively.
[Both] call log stores latest 100 data of above both directions.
- * When [7 Standard] or [8 Streaming] is selected, [Transmission menu screen] is not displayed and the screen is transited to [List menu screen] directly, because they have no direction like [Out] or [In].

7.7.1 Call Log list menu

(MENU+7+1 to 8)

In this menu, user can display the detailed information of selected communication log.

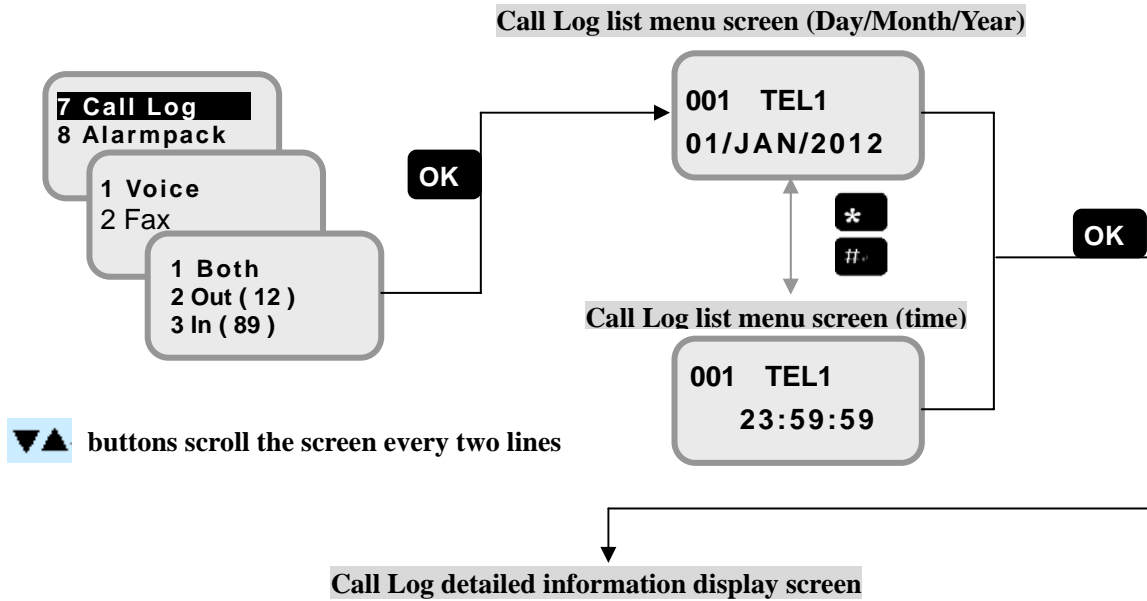

(Voice/Fax/Audio/UDI/RDI are selected)

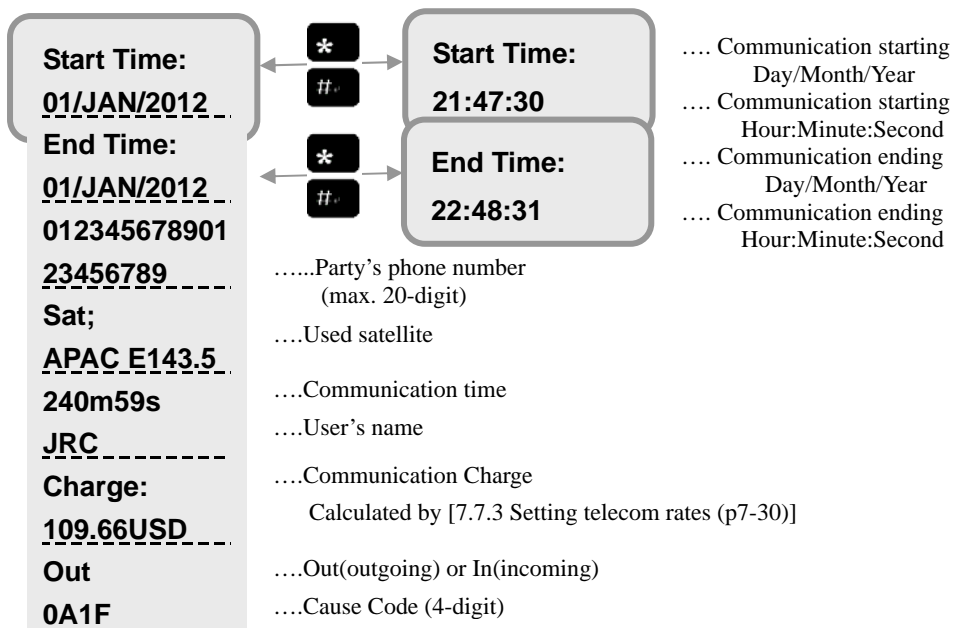

7. Handset Menu System

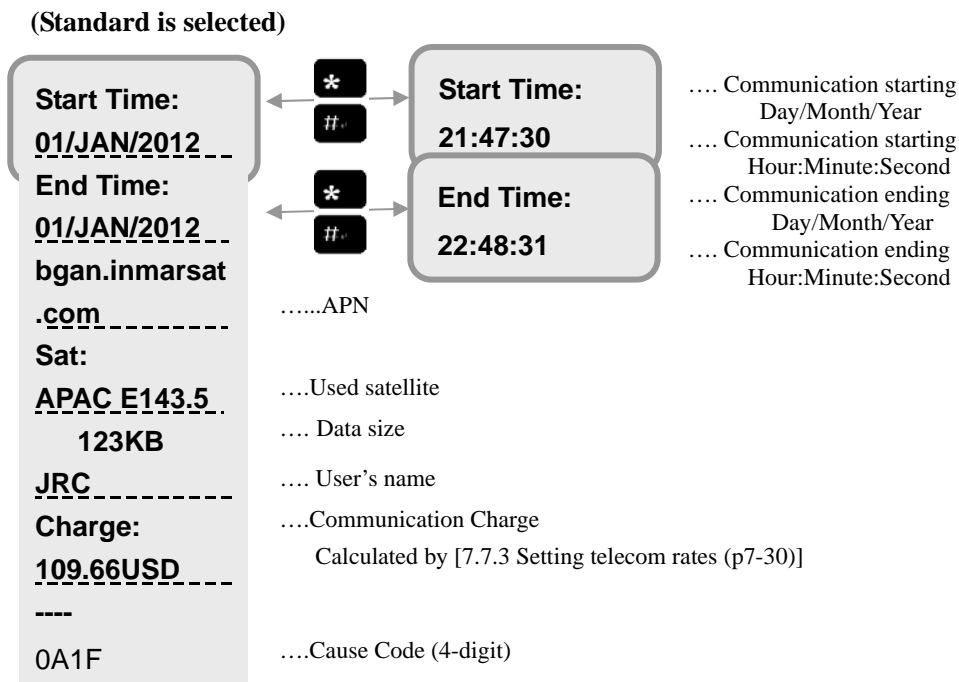
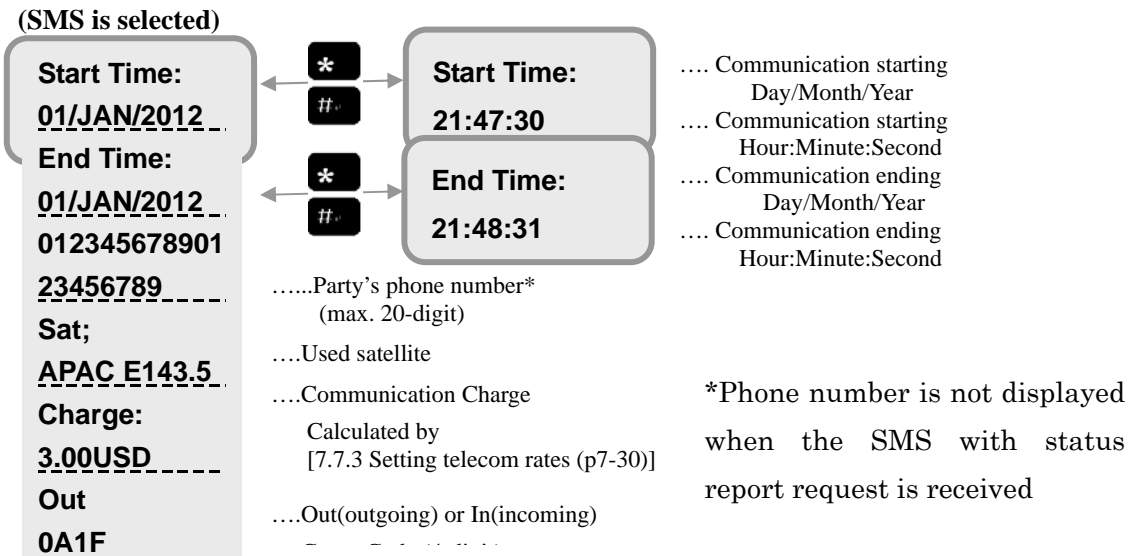

The screen is scrolled line by line with

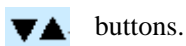

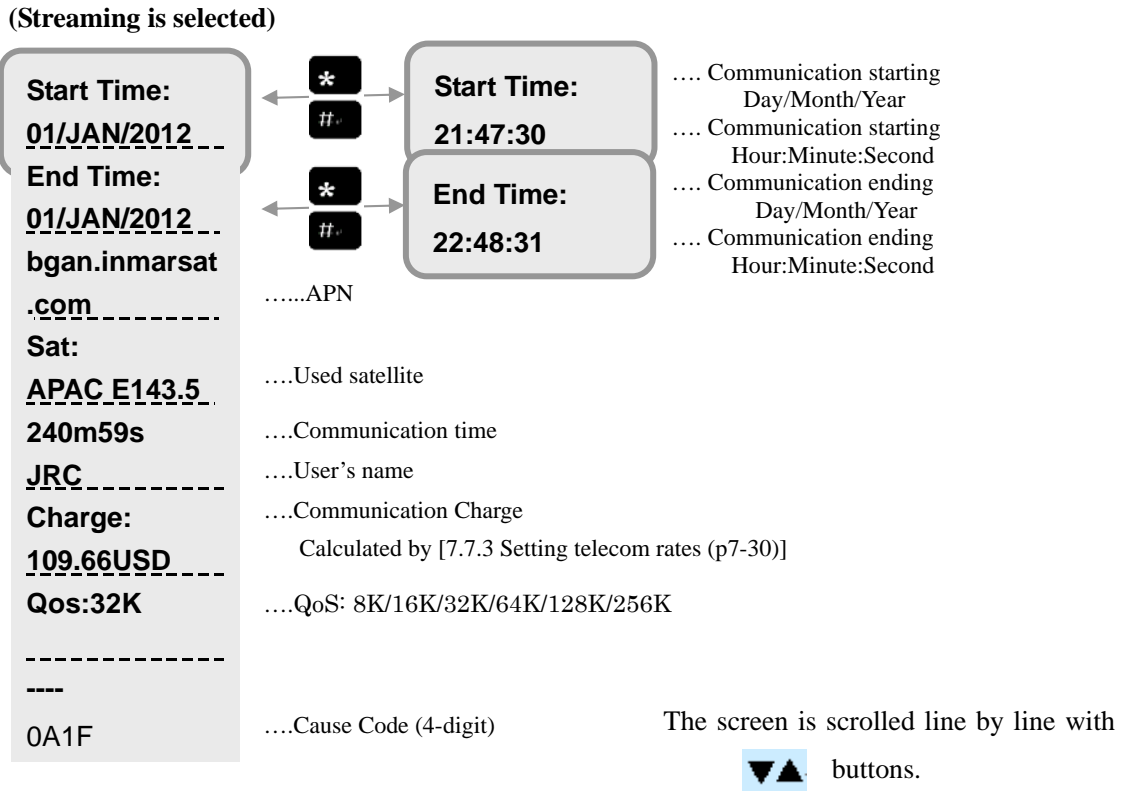

Fig. 7.7.1 Call Log list menu

7.7.2 Call Log authentication and deletion

(MENU)+7+(MENU)

In this menu, Admin user can delete the Call Log. To delete Call Log, user must pass the [Call Log authentication screen] entering secret code.

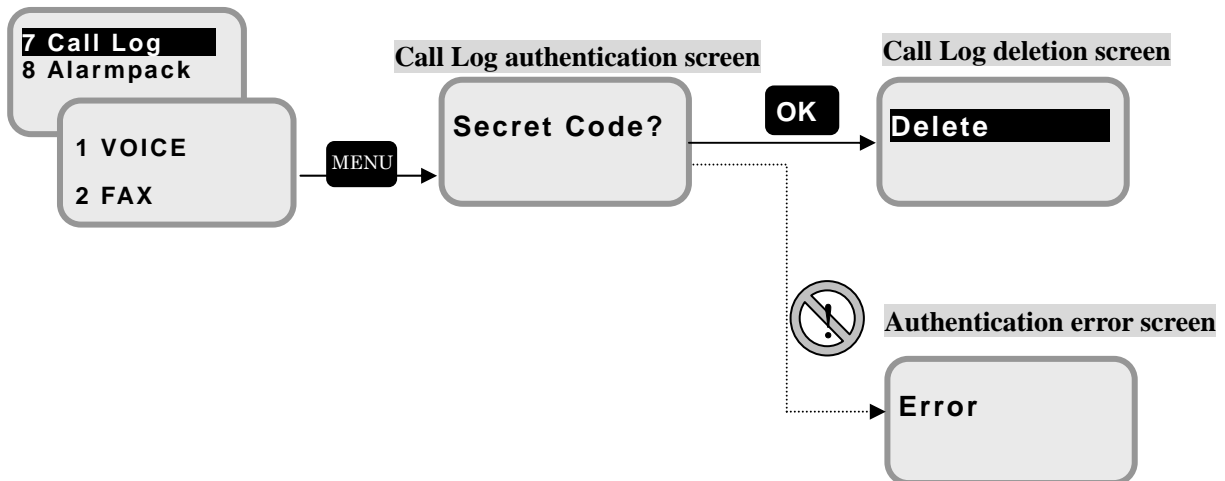

Fig. 7.7.2 Call Log authentication and deletion screen

7.7.3 Setting telecom rates

(MENU+7+9+1 to2)

In this menu, user can set call charge for each communication method. Select [9 Charge Set] at [Call Log menu screen] and [Charge Set menu screen] is displayed.

To set currency, select [1 Currency] and choose currency from USD, EUR and JPY.

To set charge rate for each communication method, Select [2 Unit] and [Unit menu screen] is displayed. Select the method and set charge rate per time (minute) for Voice, Fax/Audio, UDI, RDI, and Streaming IP connection (for each speed), per mail for SMS and per data size (MB) for Standard IP connection. [3 UDI] and [4 RDI] menus in [Unit menu screen] and [6 256K] in [Streaming Speed screen] are not displayed for JUE-251.

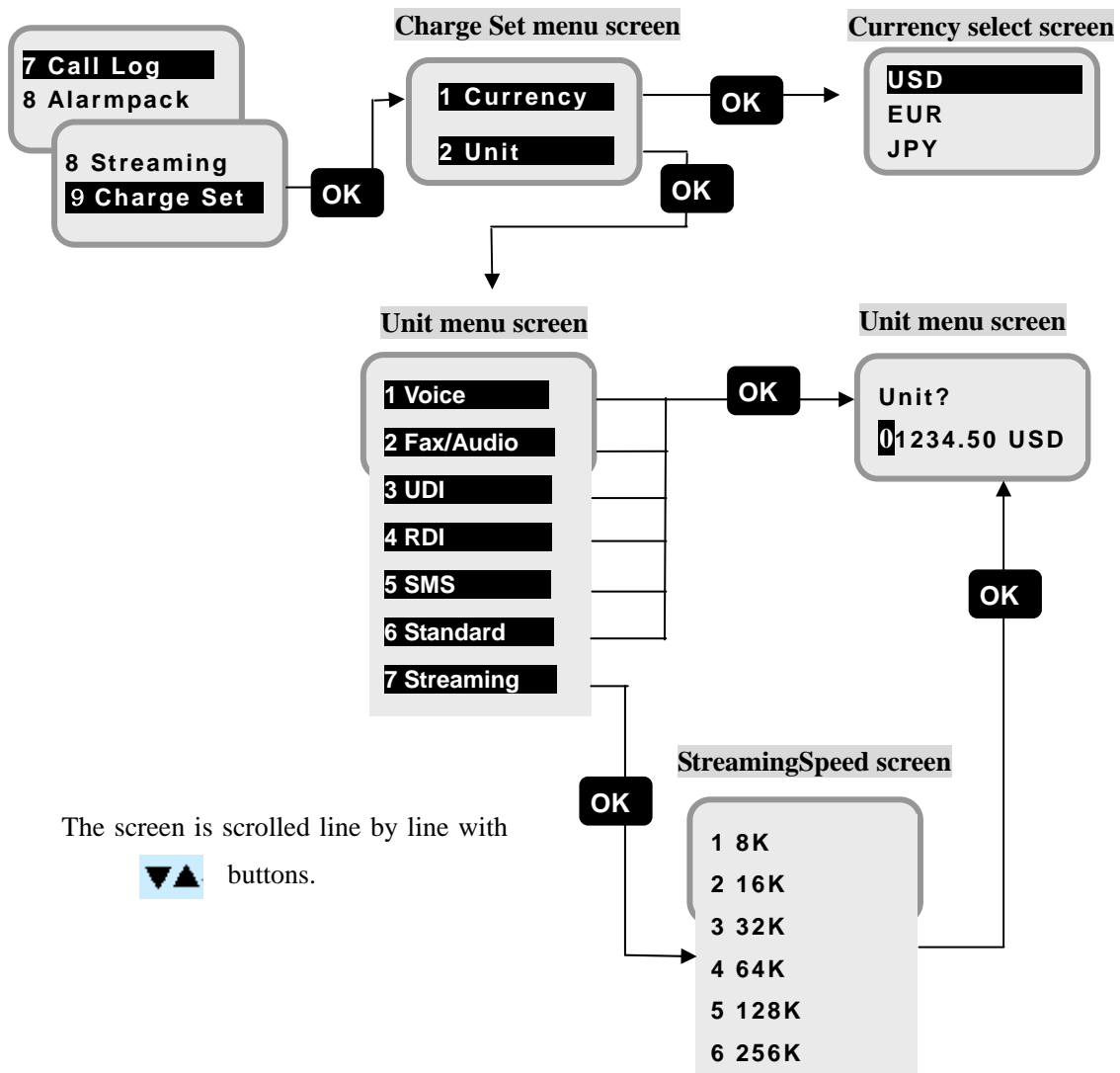

Fig. 7.7.3 Charge Set menu (JUE-501)

* [3 UDI] and [4 RDI] menus are not displayed for JUE-251.

7.8 Alarmpack menu

(MENU+8)

In this menu, user can display the latest 50 alarms.

Select [Alarmpack] from Top menu screen and press **OK** button, then [Alarm history view menu screen] (Displays the Day/Month/Year) is displayed. It displays from the latest one.

To confirm the more detailed time, [Alarm history detailed menu] (displays recorded Hour/Minute/Second of each alarm) is displayed with the ***** or **#** button pressed.

In both screens, select the preferred number and press **OK** button with selecting history number by cursor.

Then [Unit selection menu] screen is displayed with the ***** placed on the device where alarm had occurred. Select the device then press **OK** button.

Then [alarm display screen] of respective unit is displayed.

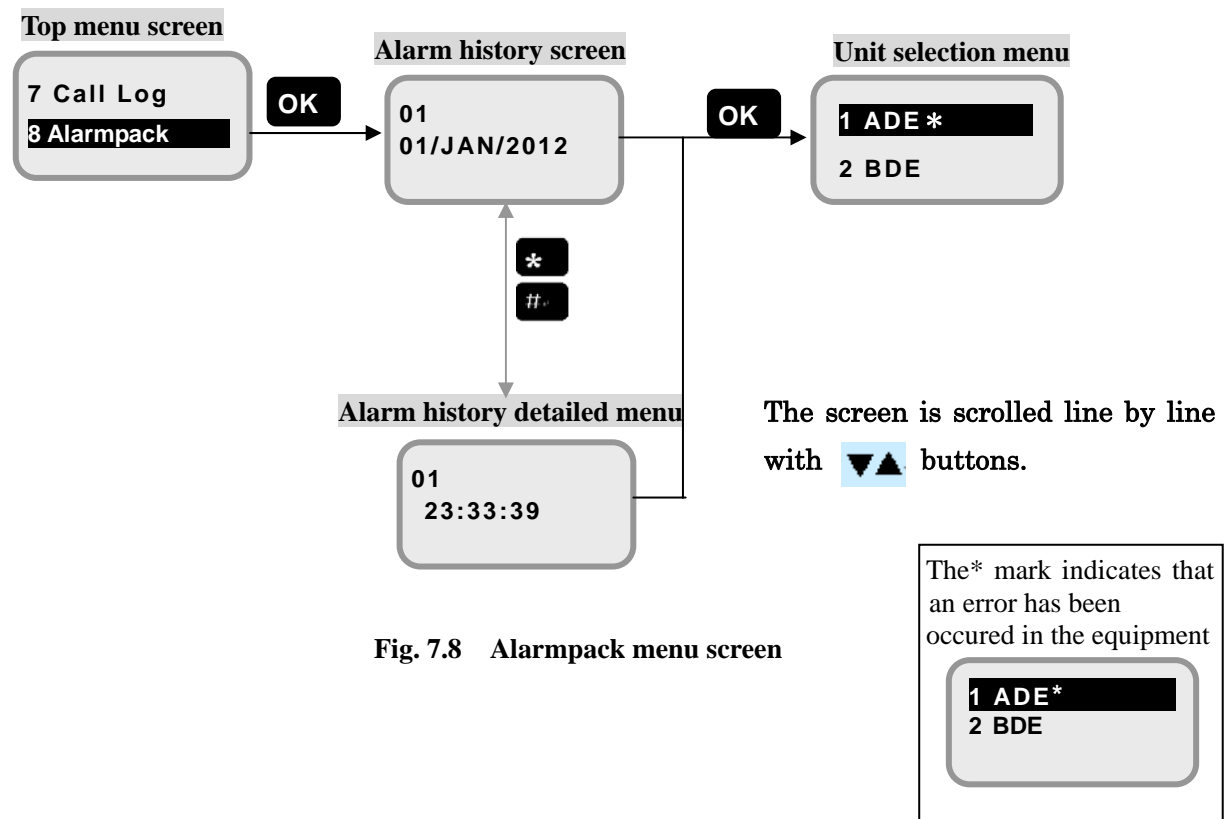

Fig. 7.8 Alarmpack menu screen

7.8.1 Unit selection menu for Alarm Pack

(**MENU**+8)

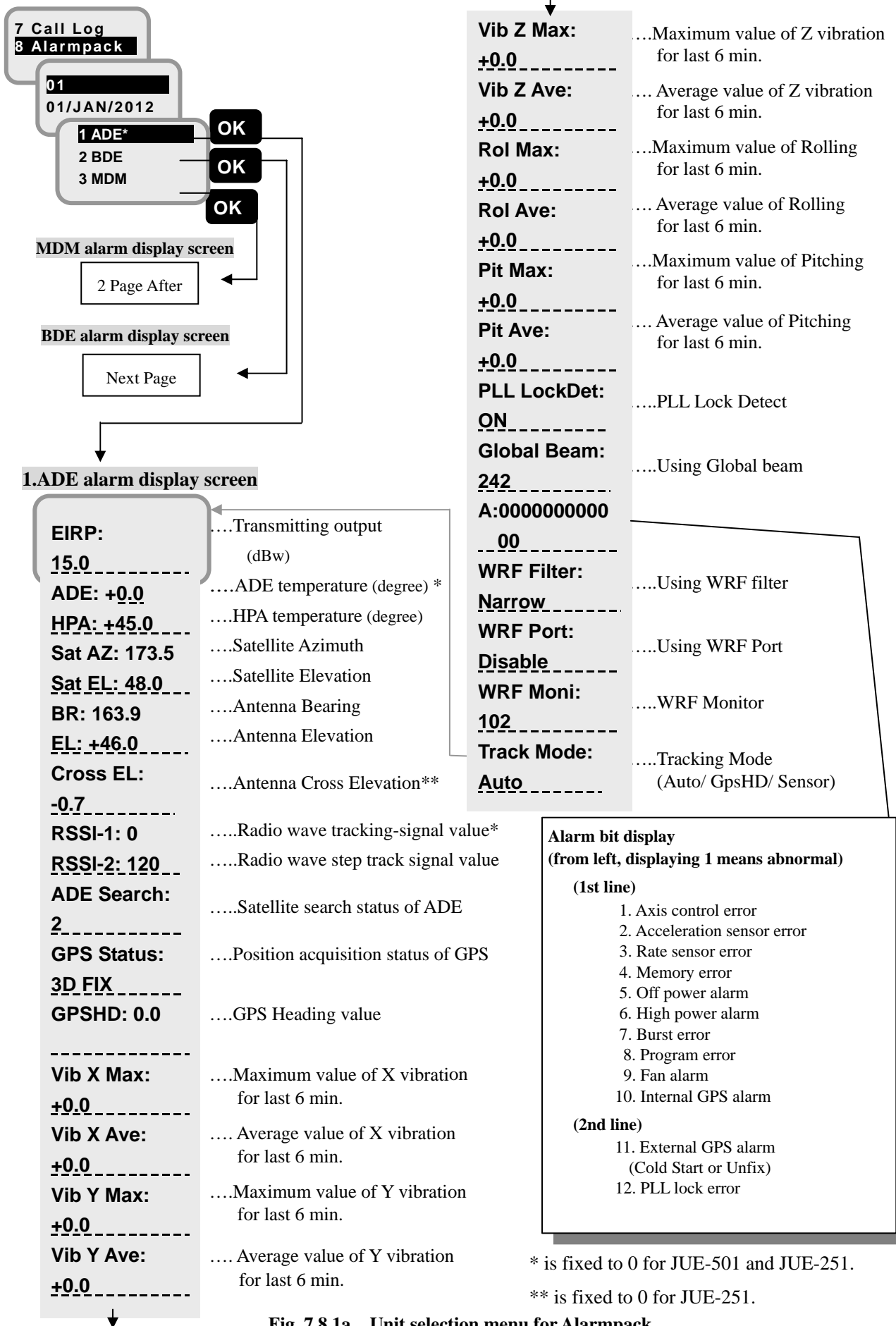

Fig. 7.8.1a Unit selection menu for Alarmpack (ADE)

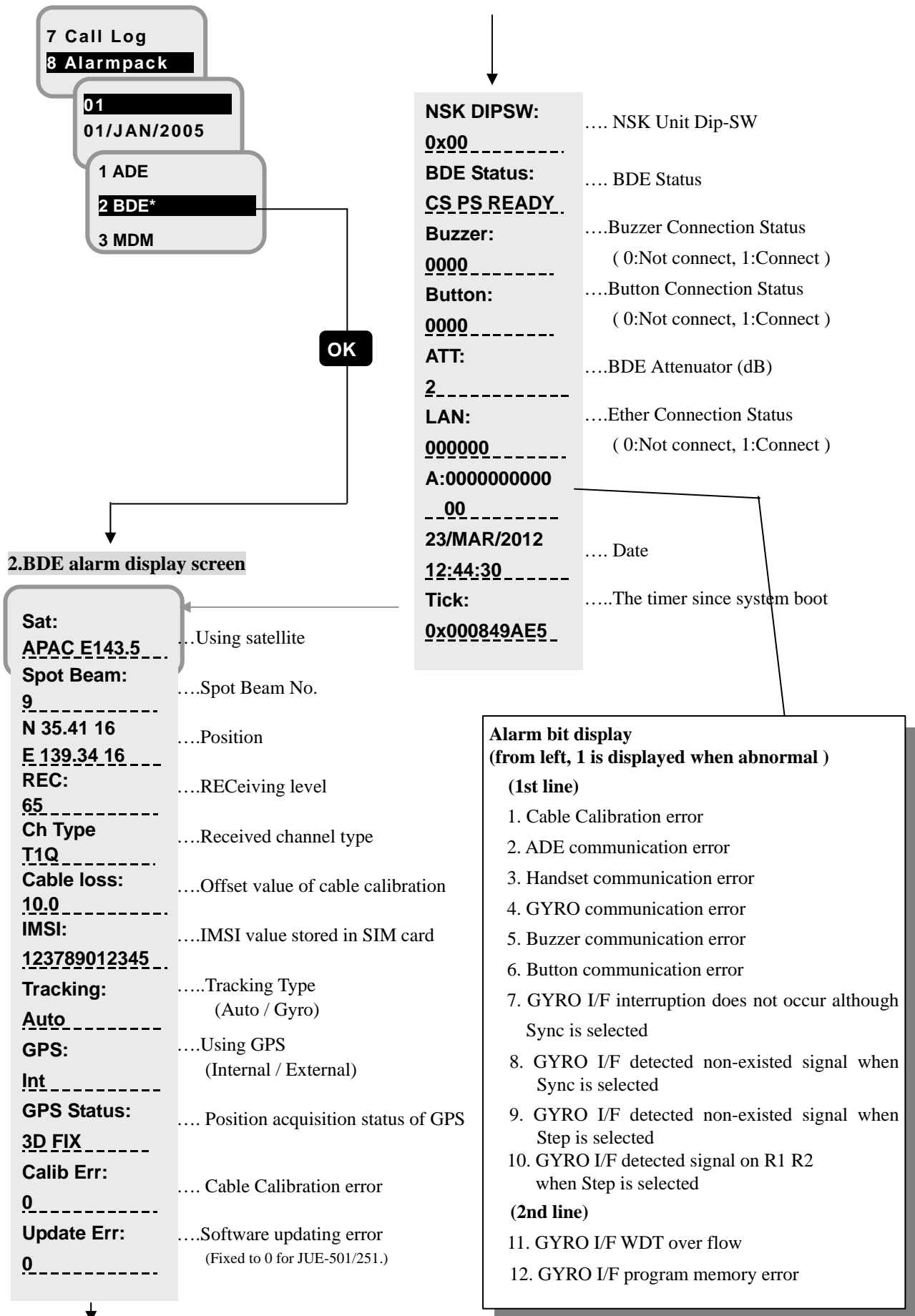

Fig. 7.8.1b Unit selection menu for Alarmpack (BDE)

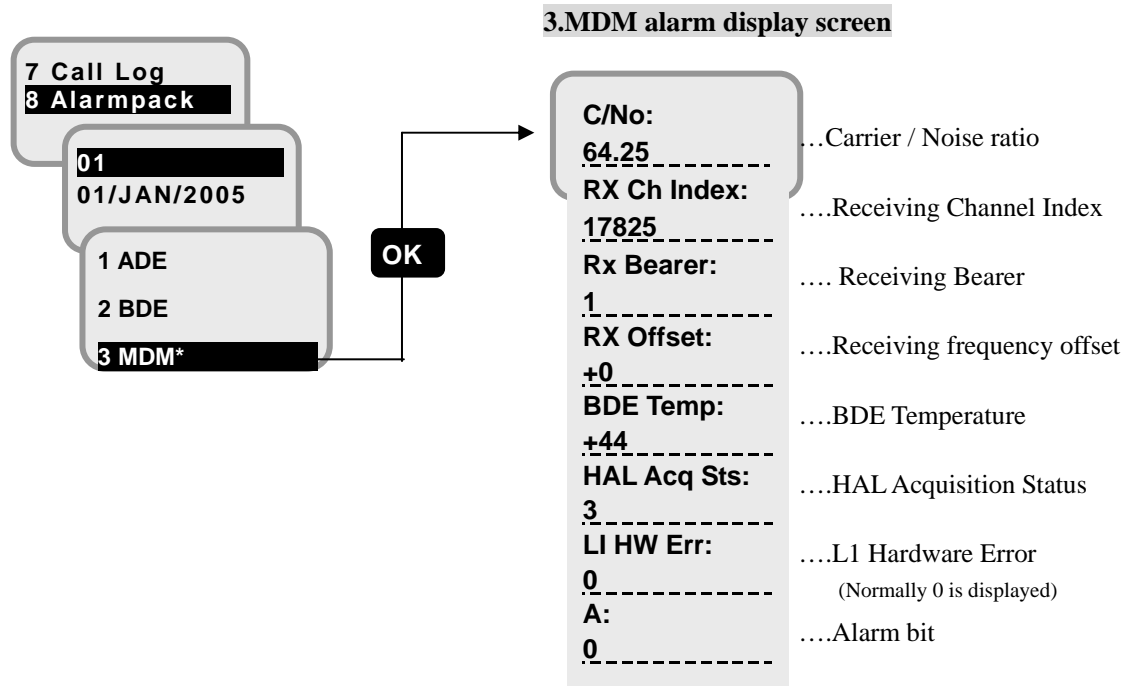

Fig. 7.8.1c Unit selection menu for Alarmpack (MDM)

7.9 Admin menu

MENU+9

[Admin menu] which displays all menus for sets up status of the JUE-501/JUE-251.

Select [9 Admin menu] from [Top menu], and display each menu screen.

Identification screen is opened when user without Admin authority enters in this menu.

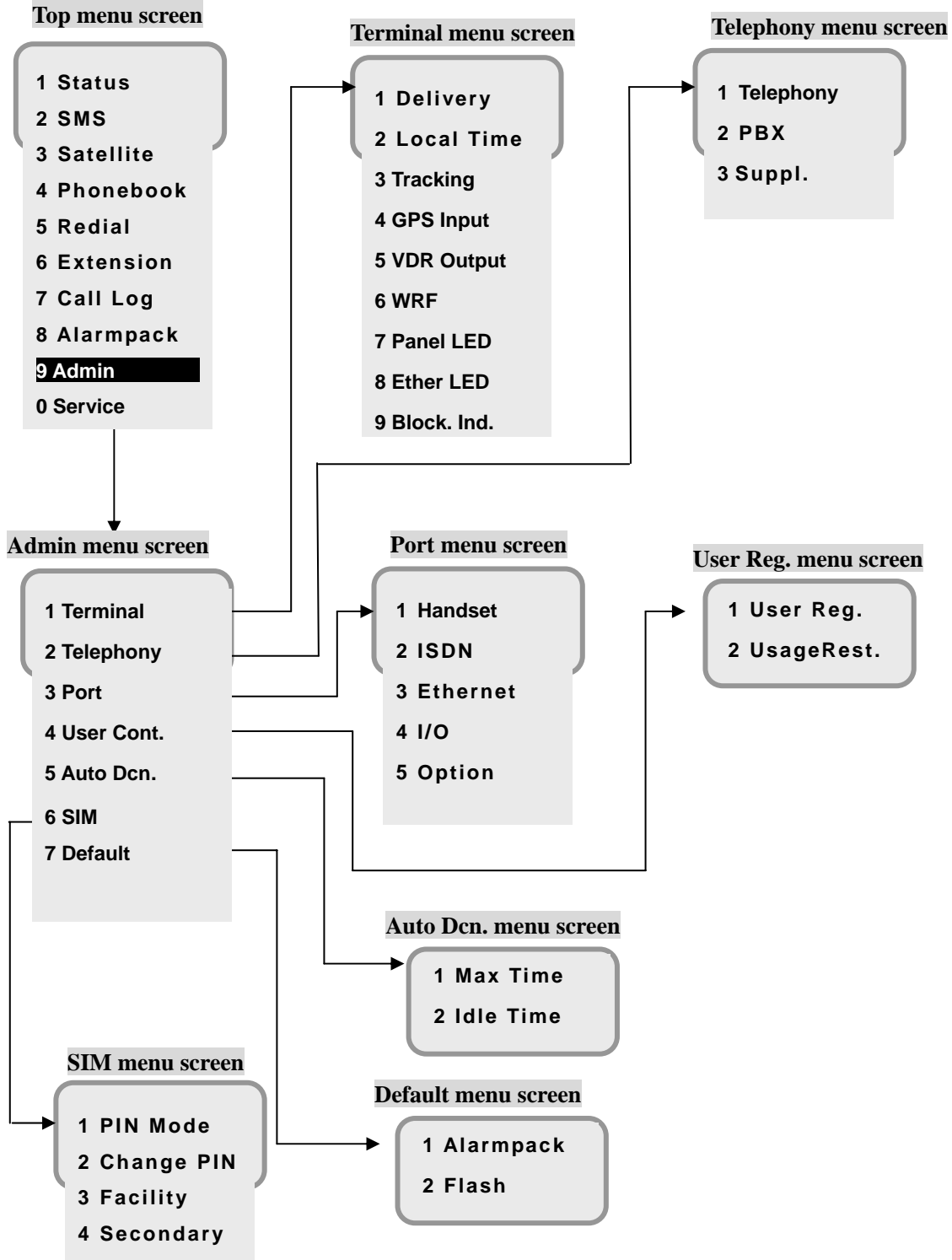

Fig. 7.9 Flow of Admin menu

7.9.1 Terminal menu

(MENU+9+1)

[Terminal menu] consists of;

- 1 **Delivery:** Delivery date of the JUE-501/JUE-251
- 2 **Local Time:** Time difference between Local time and Universal time
- 3 **Tracking:** Selection for tracking system, AUTO (signal tracking) or GYRO tracking
- 4 **GPS Input:** Selection for GPS input method
- 5 **VDR Output:** Selection for VDR output method
- 6 **WRF:** Enable/Disable using Wide-band Radio Frequency
- 7 **Panel LED:** Setting of ON/OFF of front panel LEDs
- 8 **Ether LED:** Setting of ON/OFF of ethernet LEDs
- 9 **Block. Ind.:** Setting of blocking area

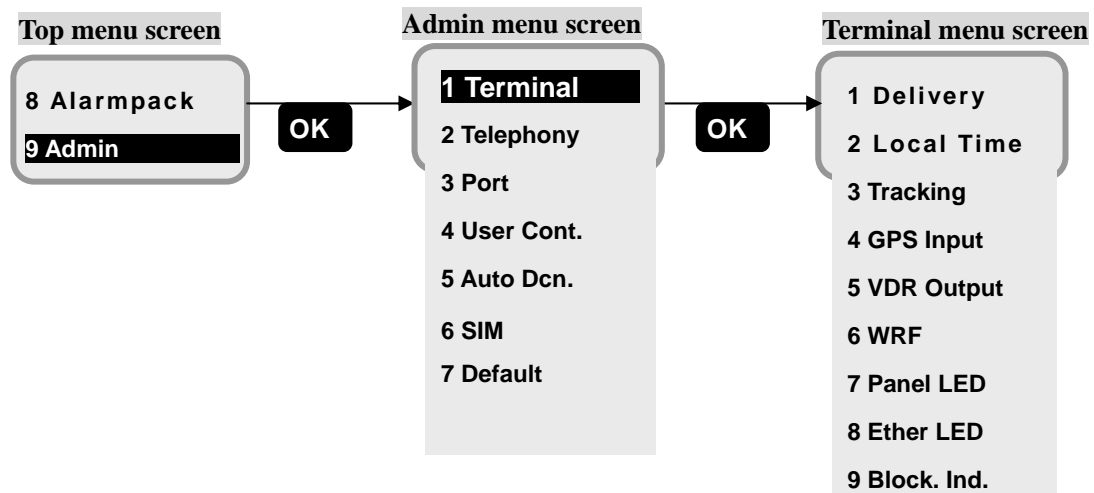

Fig. 7. 9.1 Terminal menu screen

7.9.1.1 Delivery setting

(MENU+9+1+1)

In this menu, the user can set up the delivery date of the JUE-501/JUE-251.

Select [1.Delivery] from Terminal menu and display setting screens. They are arranged in a sequence of Day, Month, and Year.

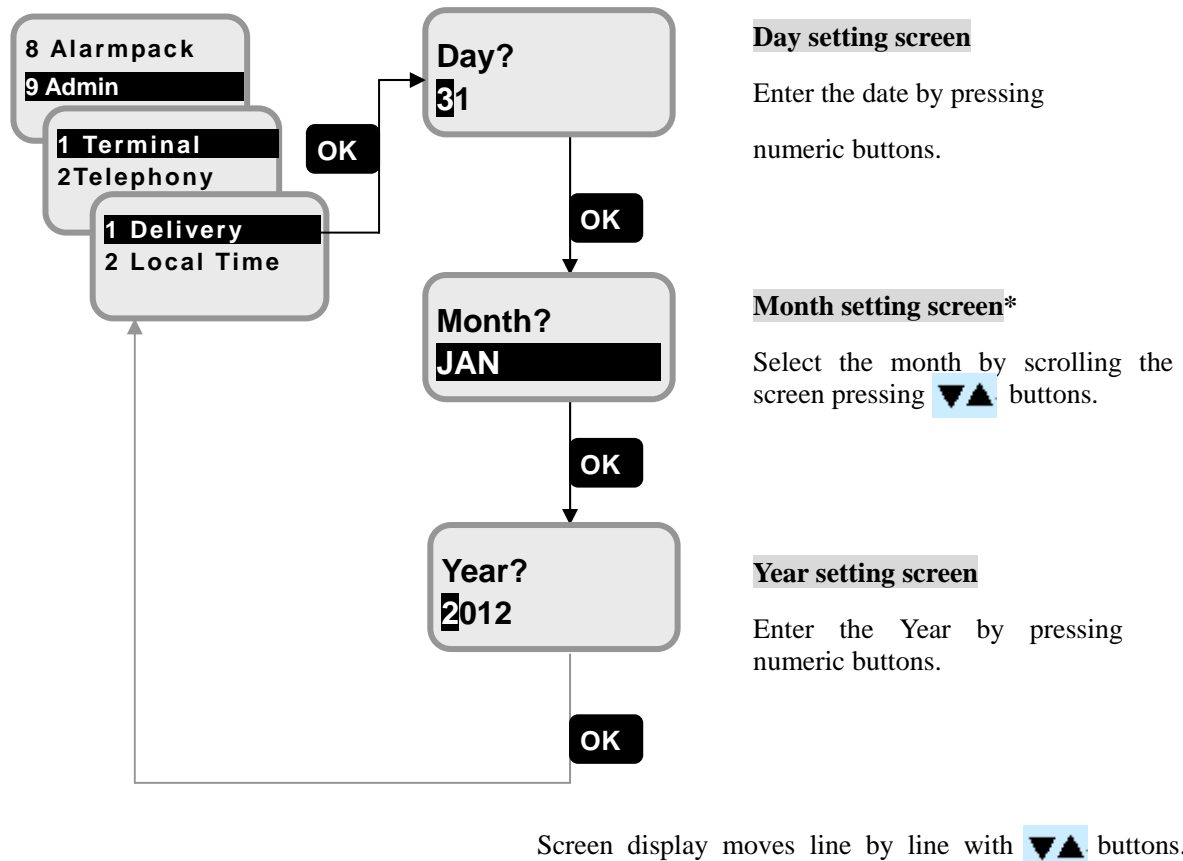

Fig. 7.9.1.1 Delivery menu screens

* button displays Months in the order of [JAN-FEB-MAR-...] and the button reverses the order.

Delivery date does not only record the day when the JUE-501/JUE-251 was installed and communication commenced, but it helps to determine the guarantee term etc.

Accurate setting is recommended.

7.9.1.2 Local Time setting (**MENU**+ **9** +**1** +**2**)

In this menu, the user can set up the time differences between UTC (Universal Time Coordinated) and Local time.

To display screens, select [2 Local Time] from Terminal menu.

First, ± setting screen is displayed. Select [+] when Local time is faster than UTC, and [-] when it is slower. Then press **OK** button.

Next, enter the time difference in [Time difference setting screen] by hours /minutes, with numeric buttons.

To return the time display to UTC, set the time difference to +00.00.

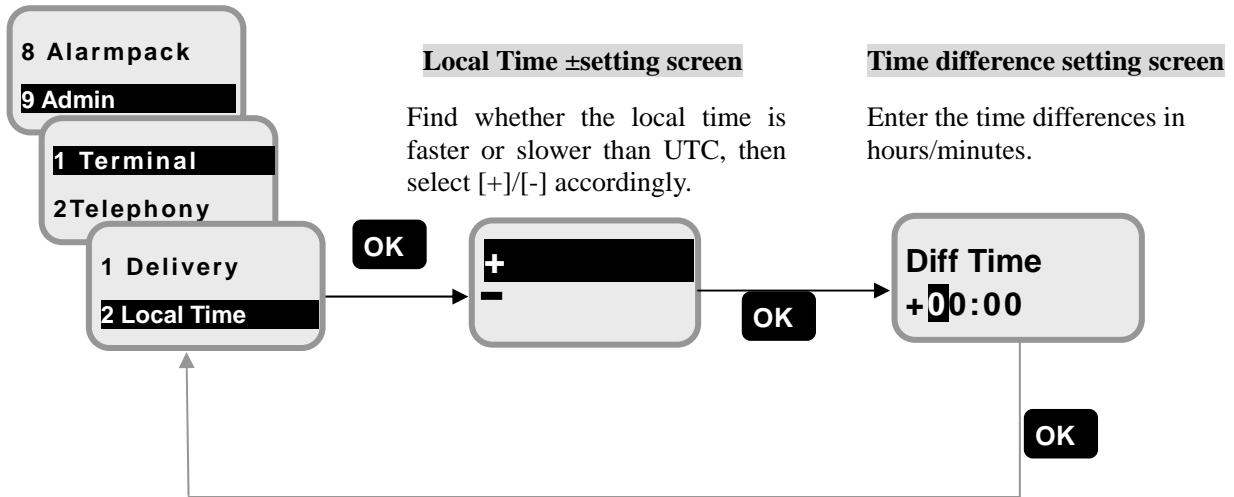

Fig. 7.9.1.2a Local Time menu screen

Example) Changing the display of Idle screen from UTC(14:03) to LT(23:03).

(Enter time difference +9hour)

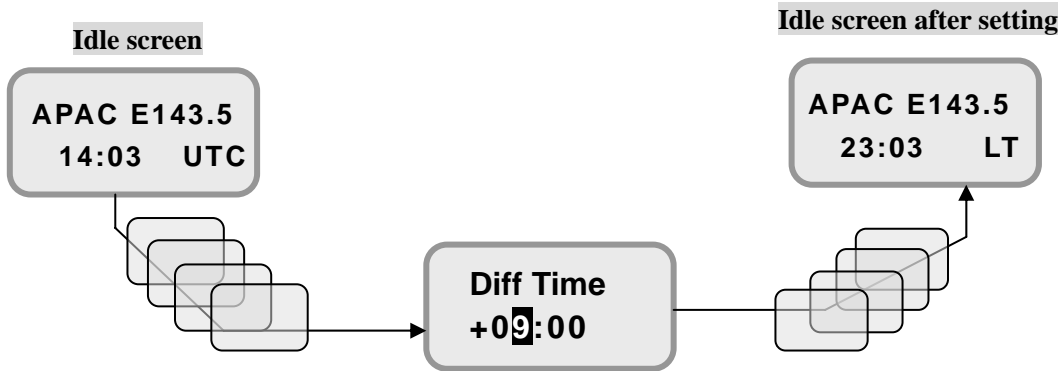

Fig.7.9.1.2b Example of setting Local Time

7.9.1.3 Tracking setting

(MENU+9+1+3)

In this menu, user can set the tracking system from [Auto] (signal tracking) or [Gyro].

When [Gyro] is selected, setting screen of the Gyro type will be appeared. If NMEA(4.8k/38.4k) and LAN of Gyro type is selected, THS, HDT, VHW can be inputted to the terminal. To enable the setting, rebooting the terminal is required.

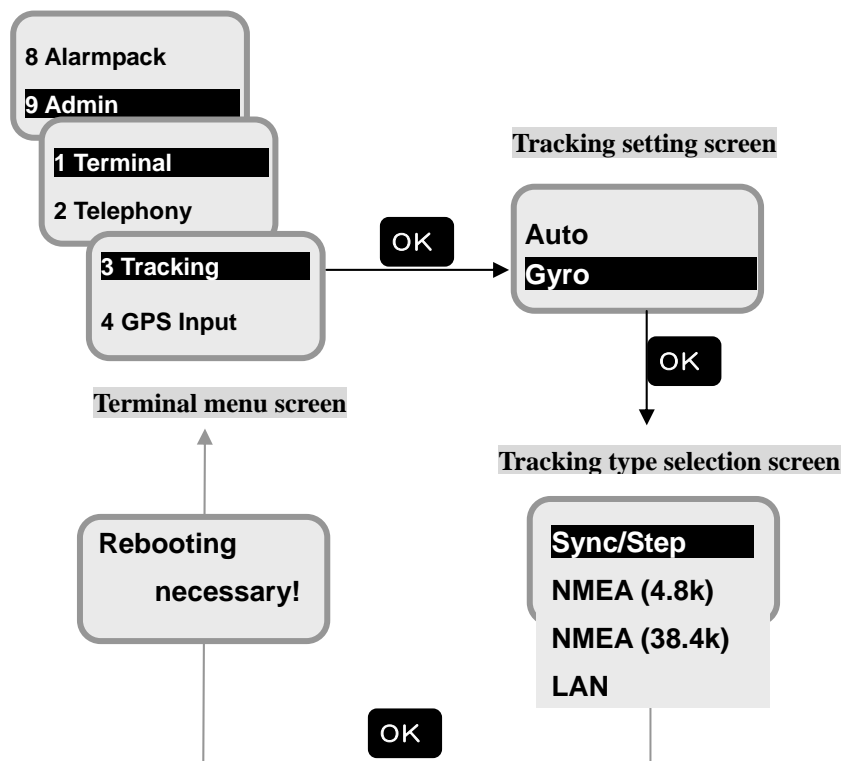

Fig. 7.9.1.3 Tracking Setting screen

7.9.1.4 GPS Input setting (MENU+9+1+4)

In this menu, user can set the input method of external GPS. Select one from “NMEA(4.8k)”, “NMEA(38.4k)”, “LAN” and “Disable”. If “Disable” is selected, the built-in GPS is used. To enable the setting, rebooting the terminal is required.

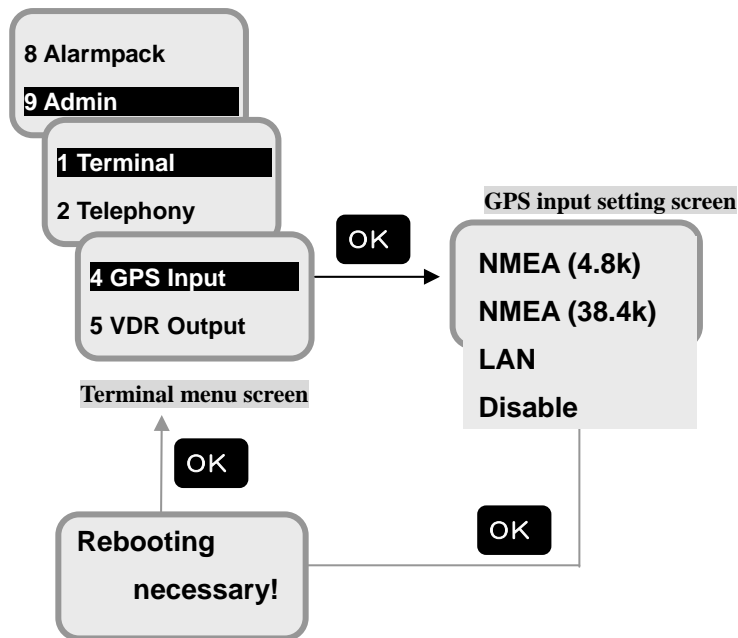

Fig. 7.9.1.4 GPS Input Setting screen

7.9.1.5 VDR Output setting

(MENU+9+1+S)

In this menu, user can set the output method for sending alarmpack of JUE-501/JUE-251 to VDR. Select one from “LAN” and “Disable”. To enable the setting, rebooting the terminal is required.

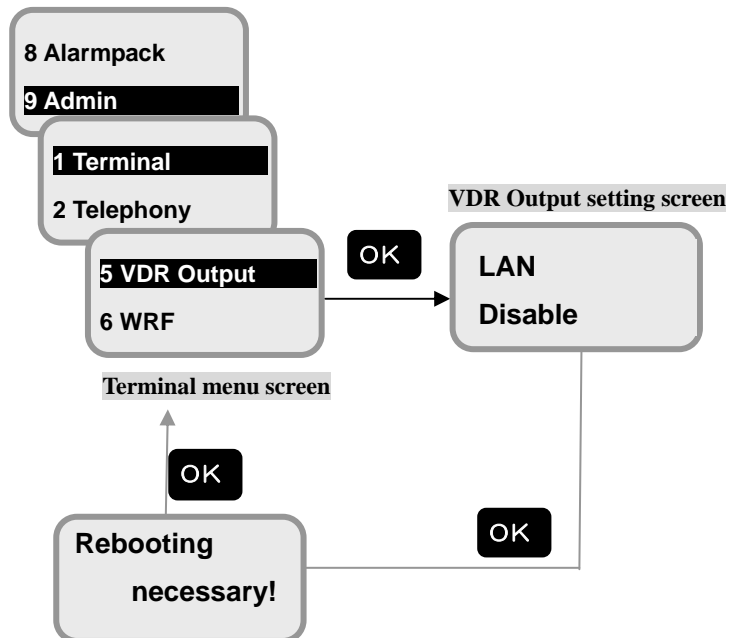

Fig. 7.9.1.5 VDR Output Setting screen

7.9.1.6 WRF setting

(**MENU**+**9**+**1**+**6**)

In this menu, user can enable/disable using the WRF (Wide-band Radio Frequency) interface. The WRF interface outputs the satellite signal directly to the navigation equipment to receive position data. "Enable" uses wide band filter. "Disable" uses narrow band filter and prevents interference of any other radio waves. "Auto" changes the using filter automatically.

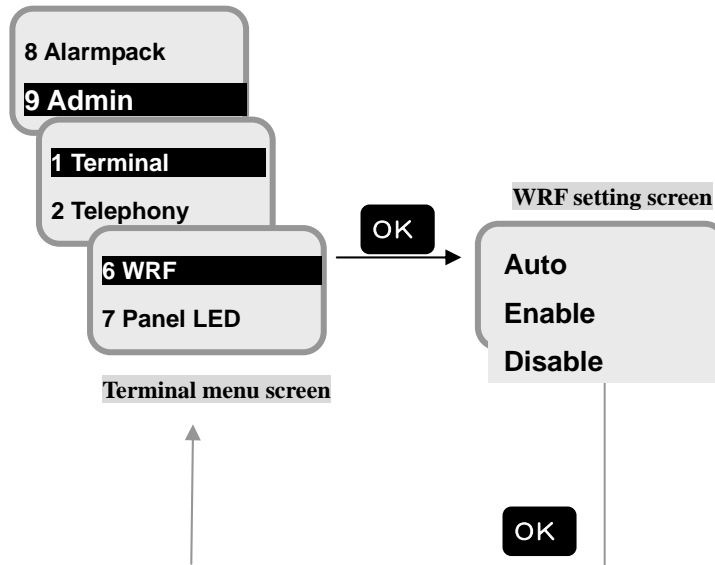

Fig. 7.9.1.6 WRF Setting screen

7.9.1.7 Panel LED setting

(MENU+9+1+7)

In this menu, user with Admin authority can set ON/OFF of the LEDs on front panel of main unit.

Select [7 Panel LED] from [Terminal menu]. Then present setting is displayed on [Panel LED setting screen].

To change the setting select ON or OFF by ▼▲ buttons and press **OK**.

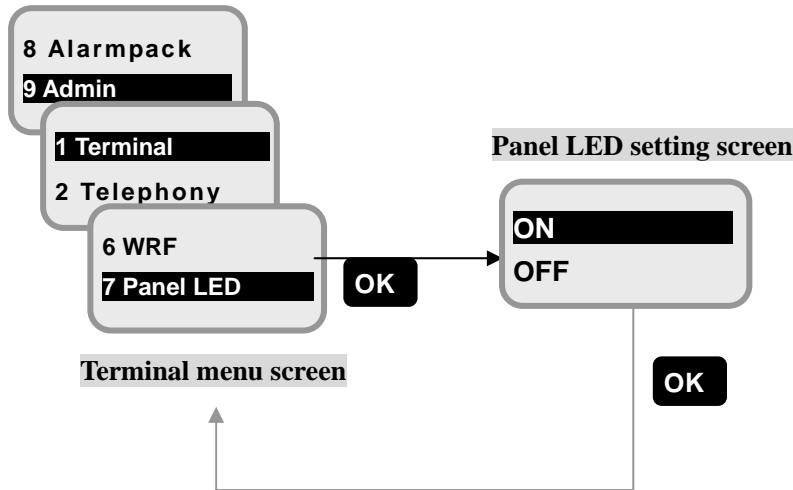

Fig. 7.9.1.7 Panel LED Setting screen

7.9.1.8 Ether LED setting

(MENU+9+1+8)

User with Admin authority can set ON/OFF of the LEDs on Ethernet connector also.

Select [8 Ether LED] from [Terminal menu]. Then present setting is displayed on [Ether LED setting screen].

To change the setting select ON or OFF by ▼▲ buttons and press **OK**.

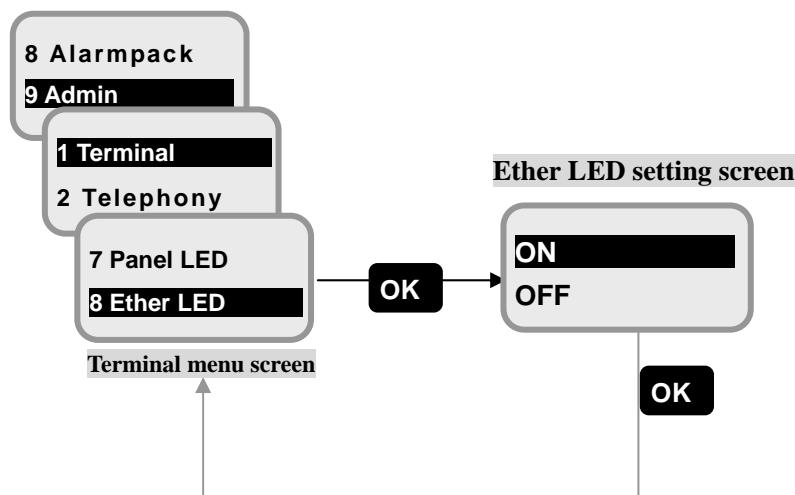

Fig. 7.9.1.8 Ether LED Setting screen

7.9.1.9 Block. Ind. setting (MENU+9+1+9)

In some area, communications on FBB system may be blocked because the antenna unit of JUE-501/JUE-251 is hidden from satellite by an obstruction like ship's mast or funnel.

In this menu, user can preset the area where the signal is blocked. Blocking indication will be shown when the antenna turns to the area. Blocking indication on Handset is blinking antenna bar icon, and on Web interface is changing color of antenna bar icon from green to orange.

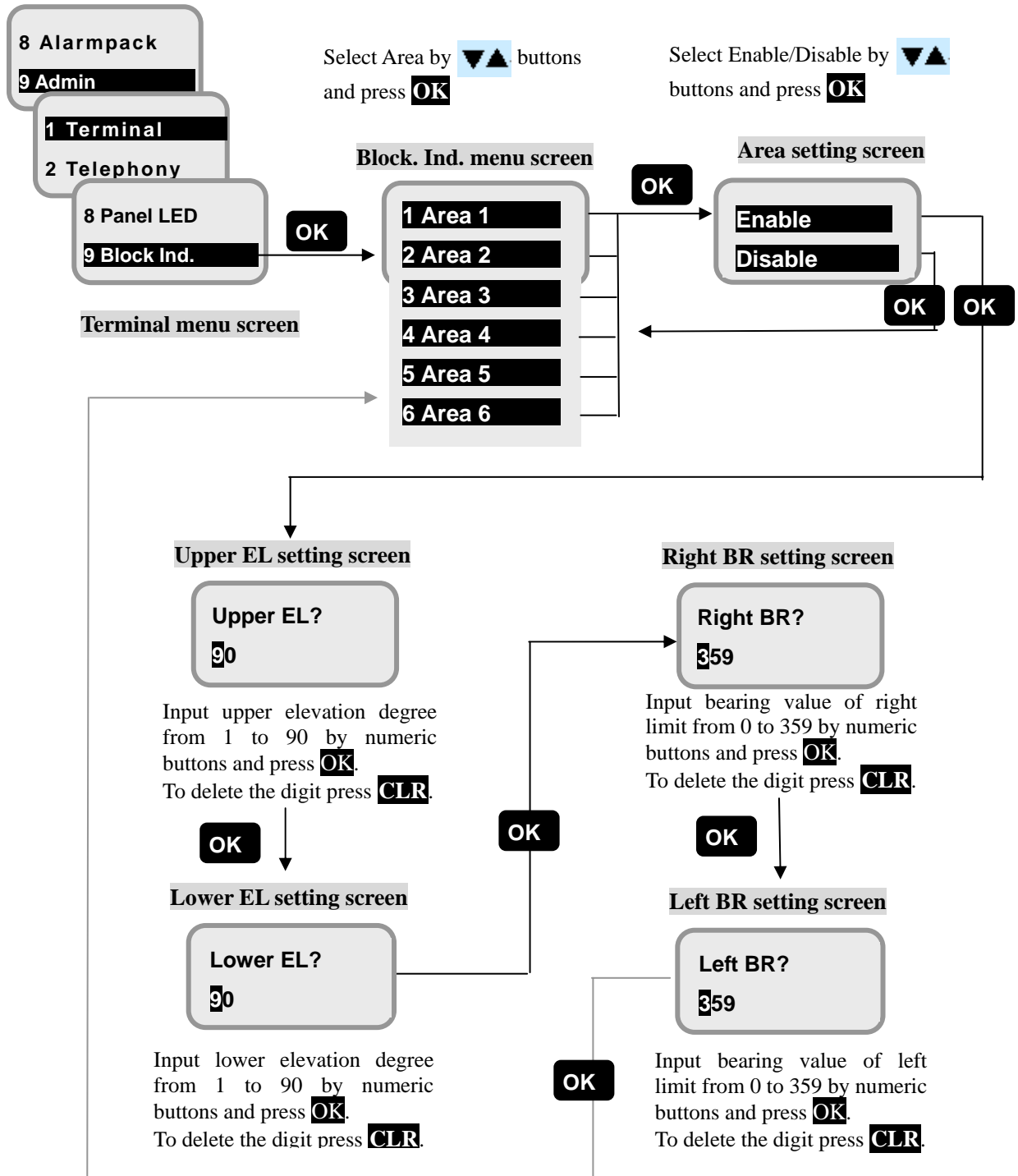

Fig. 7.9.1.9 Block. Ind. Setting screen

7.9.2 Telephony menu(**MENU**+ **9**+**2**)

In this menu, user can set Telephony setting, PBX setting and Suppl. setting. These functions can be set by Web interface also (refer to [6.5.2.1 Set up Port (p6-34)]).

7.9.2.1 Telephony (basic telephony function) setting

Settings for basic telephony function. User can set operation limit, voice volume, outgoing/incoming service type, restriction for outgoing call and call up time for each port (Handset/ TEL1~6/ ISDN).

7.9.2.2 PBX (auto answer function) setting

Settings for auto answer function. When auto answer is enabled, a fixed message (Please dial 3 digits extension number followed hash or dial aster for main number.) is reproduced automatically. The main unit waits for input from the caller for set time. If no input is recognized, the call will be forwarded to the default destination.

7.9.2.3 Suppl. setting

Settings for telephony supplementary function. This subsection contains displaying voice mail service number and settings for call forwarding, call waiting and call barring.

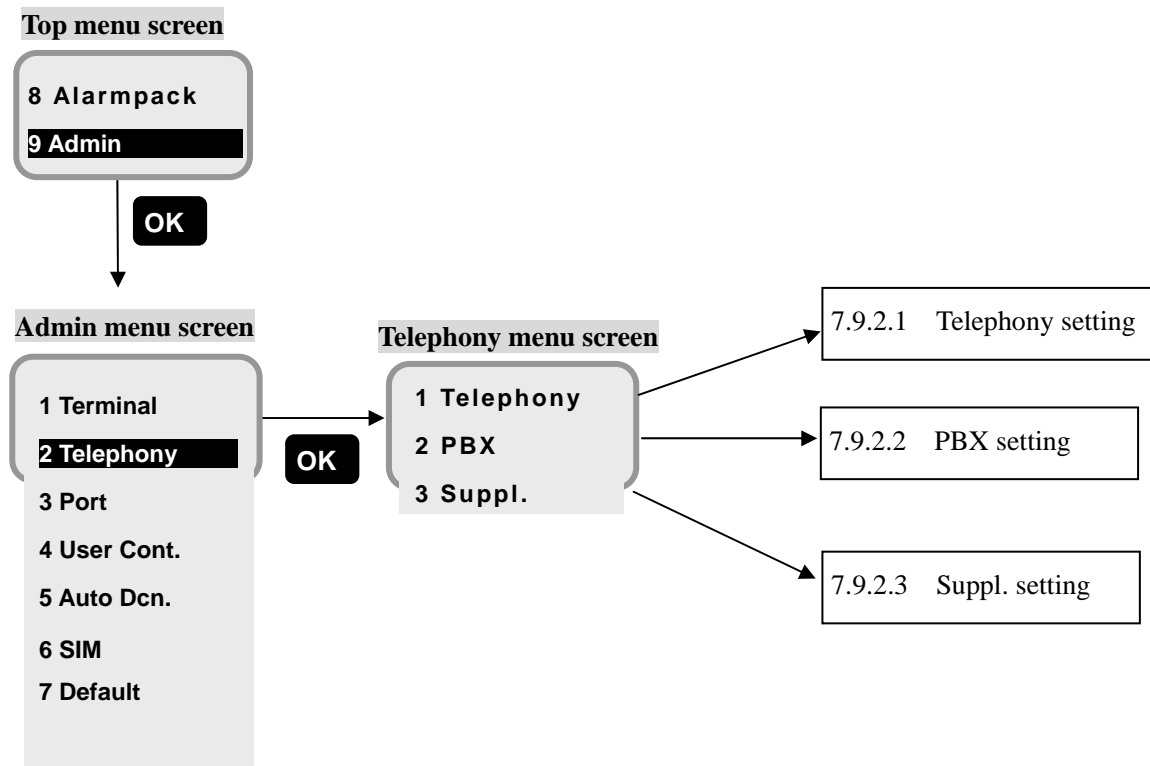



Fig. 7.9.2 Telephony menu screen

7.9.2.1 Telephony setting

(**MENU**+ **9**+**2**+**1**+**1**+**8**)

In this menu, the user can execute the various setting to communication ports (Handset, TEL1~6, and ISDN) respectively. Select setting port by  button and press **OK**.

- Secret Code: Sets operation limit. This menu is not displayed when [8 ISDN] is selected at [Telephony setting item selection screen].
 - “Enable” requires secret code to make an outside call from the terminal connected to the port.
 - “Disable” doesn’t require secret code so that anyone can make an outside call from the terminal connected to the port.
- Voice Vol.: Sets volume of voice output. This menu is not displayed when [8 ISDN] is selected at [Telephony setting item selection screen].
 - “Normal” sets normal volume and “High” sets loud volume.
- Out Type/In Type: Sets Outgoing/Incoming service type (Voice /Fax/Audio). This menu is not displayed when [1 Handset] is selected at [Telephony setting item selection screen].
 - “Voice” sets service type 4k AMBE service.
 - “Fax” sets service type Fax.
 - “Audio” sets service type 3.1 kHz Audio service.
 - “Voice/Fax” sets service type 4k AMBE service and Fax.
 - “Voice/Audio” sets service type 4k AMBE service and 3.1 kHz Audio service.
- Out Call: Sets the permission/prohibition of originating a call.
 - “Enable” sets no limitation.
 - “AllowedNum” permits making a call only to the allowed phone numbers. The allowed number list contains a maximum of four phone numbers. It also permits making a call to a phone number which begins with the listed number. (Setting 0081 permits making a call to 0081xxxx.)
 - “Phonebook” permits making call to numbers registered in phonebook.
 - “Disable” denies all outgoing call.
 - * Making internal call is always allowed.
- In Call: Sets the call up time after a call arrived to main unit by the time (seconds) selection.
 - “Enable” rings when a call arrives on main unit.
 - “After Xs” rings after X seconds later since a call has arrived on main unit.
 - “Disable” rings no sound.

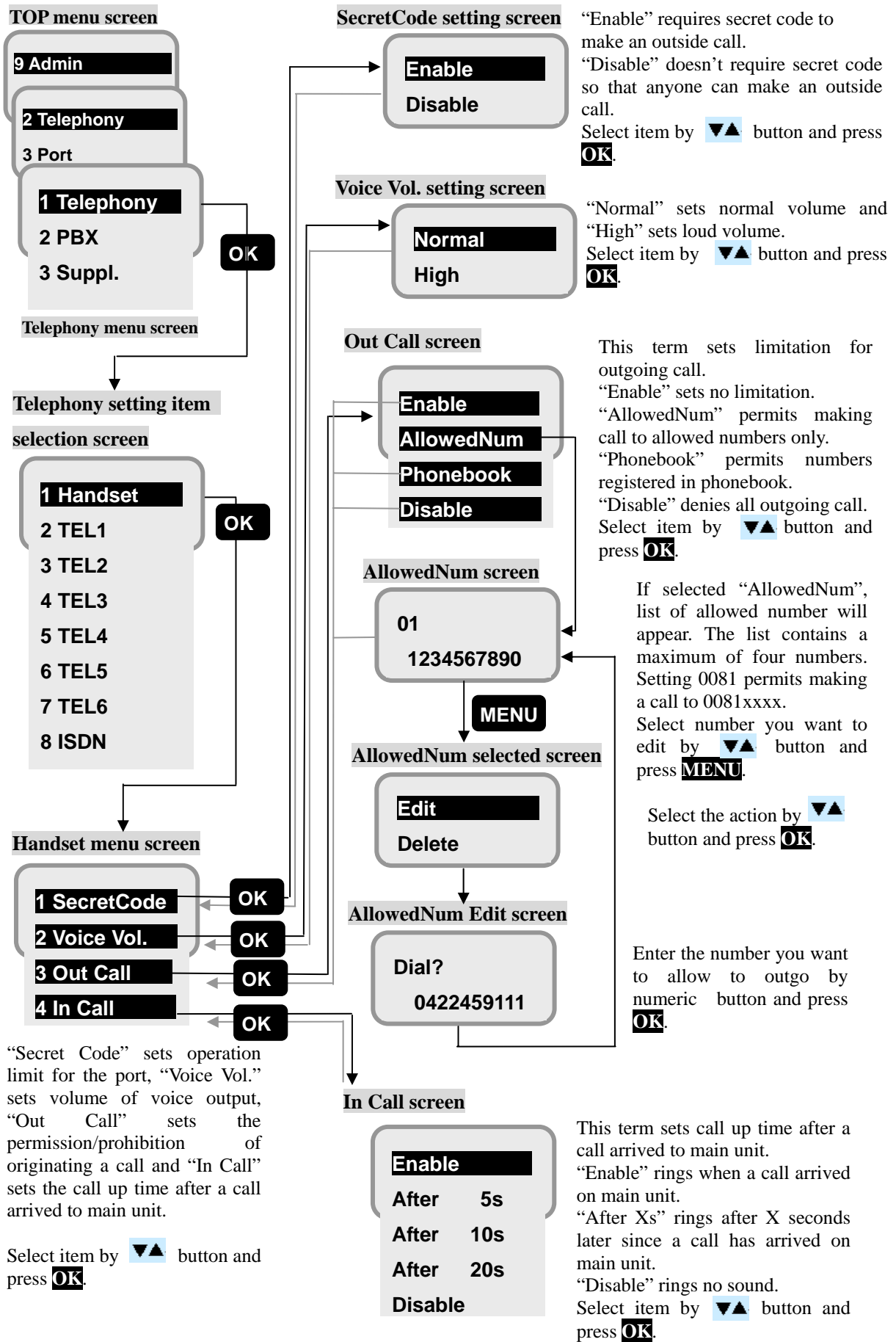

Fig 7.9.2.1a Flow of port setting (Handset)

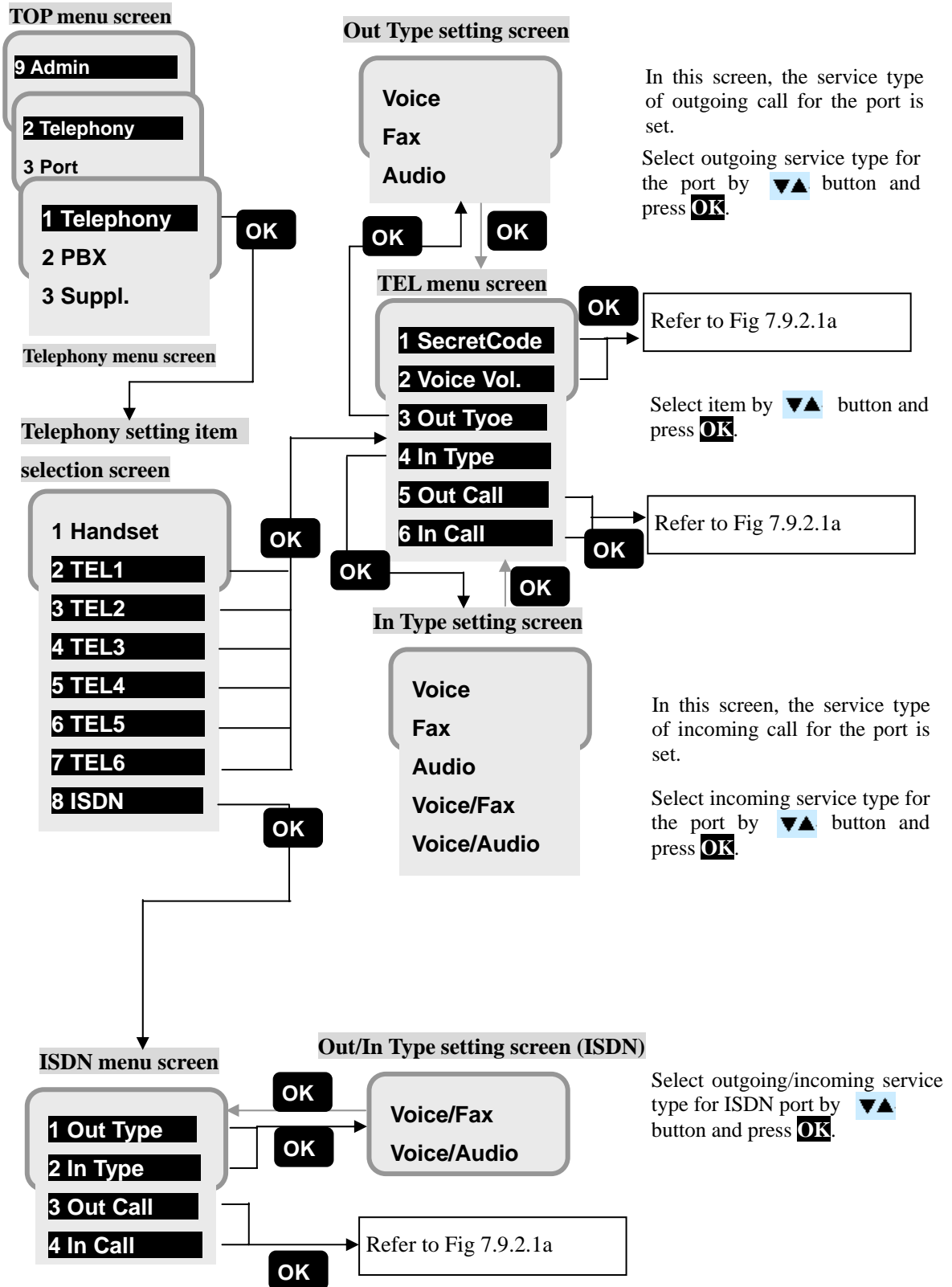

Fig 7.9.2.1b Flow of port setting (TEL ports and ISDN port)

7.9.2.2 PBX setting

(**MENU**+ **9**+**2**+**2**+**1**)

In this menu, user can set items about auto answer. When auto answer is enabled, a fixed message (Please dial 3 digits extension number followed hash or dial aster for main number.) is reproduced automatically. The main unit waits for input from the caller for set time. If no input is recognized, the call will be forwarded to the default destination.

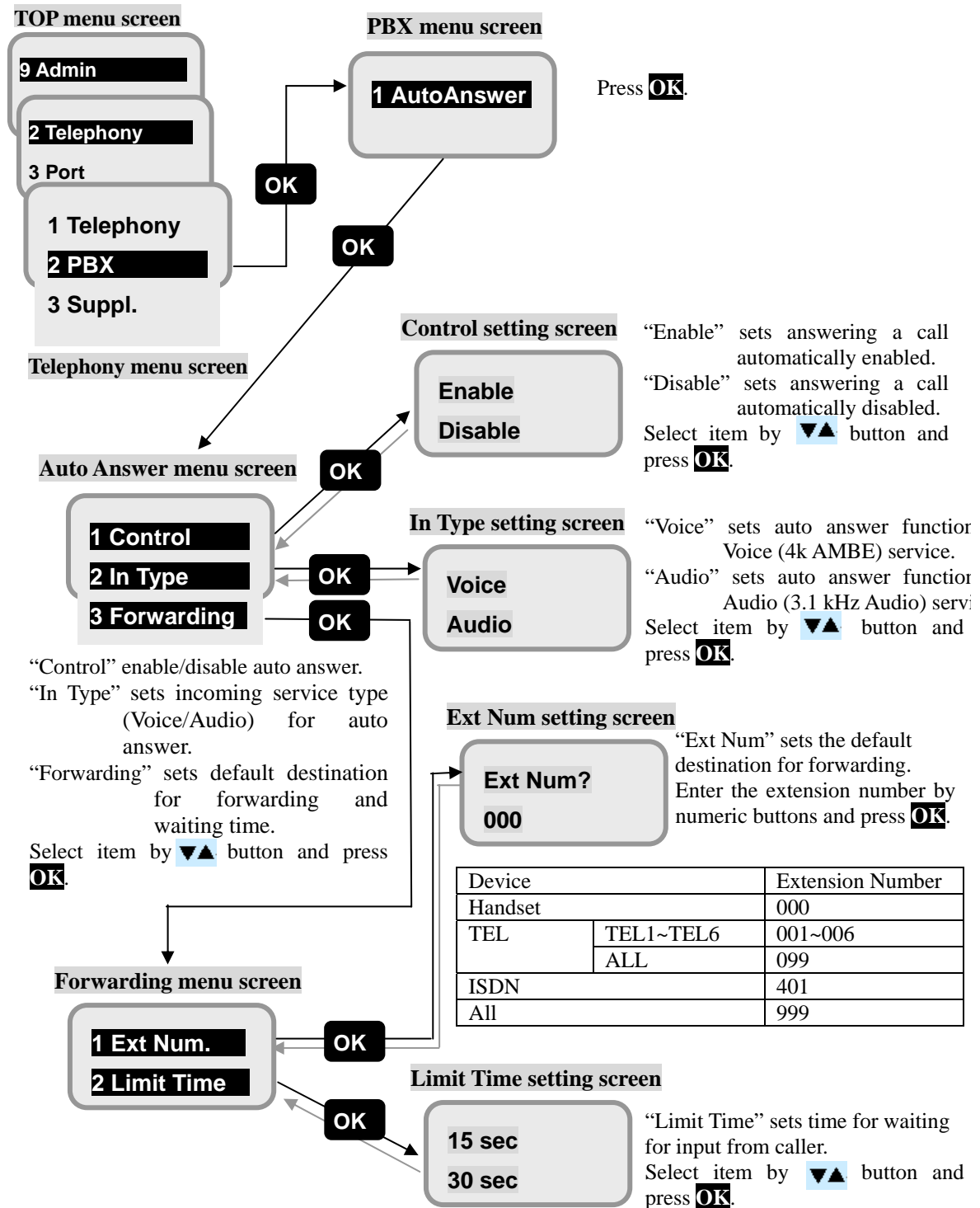

Fig 7.9.2.2 Flow of PBX setting screen

7.9.2.3 Suppl. setting (MENU+ 9 +2 +3+1~ 4)

In this menu, user can set telephony supplementary service. This subsection contains displaying voice mail service number and settings for call forwarding, call waiting and call barring.

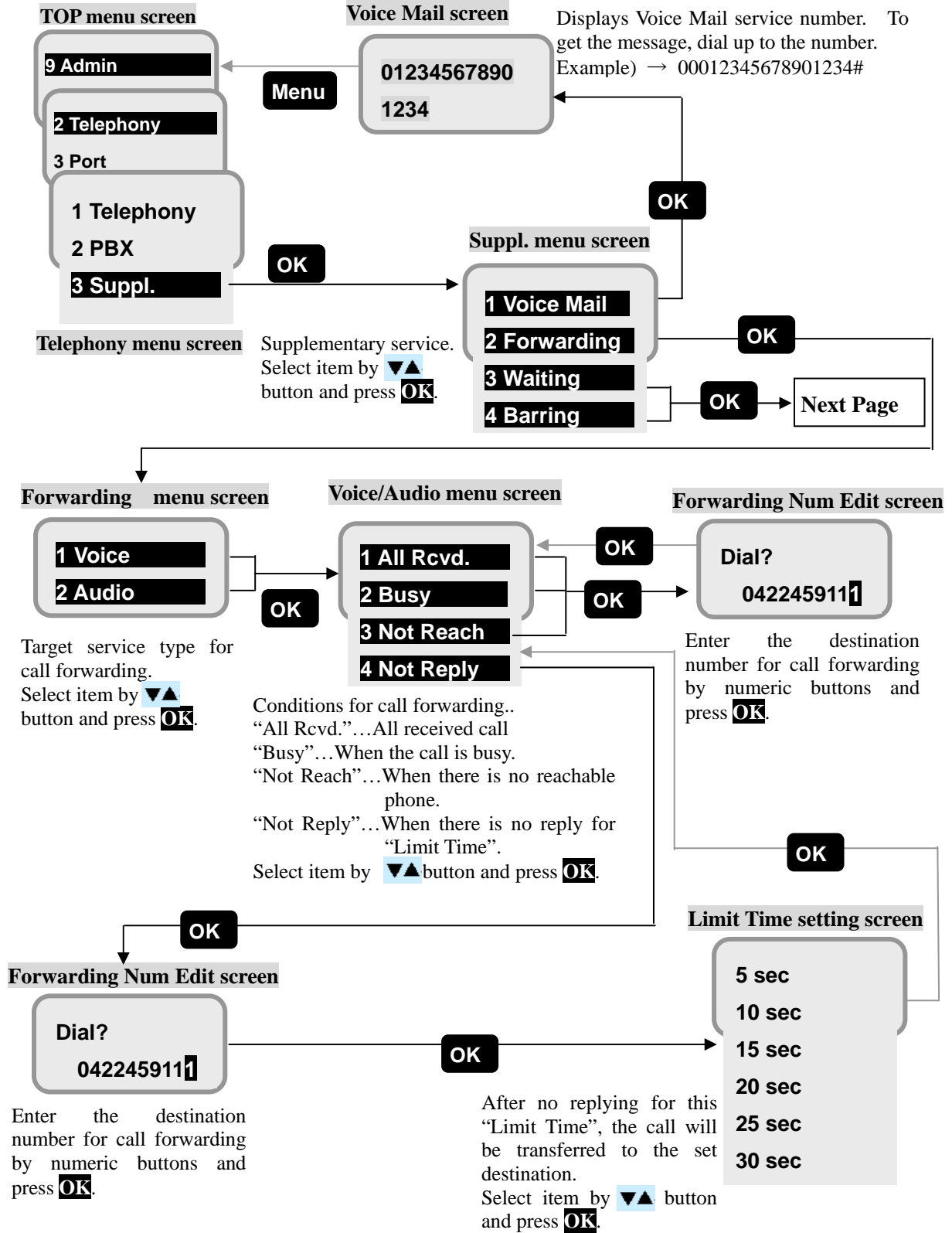

Fig 7.9.2.3a Flow of Voice Mail Number Displaying /Forwarding setting screen

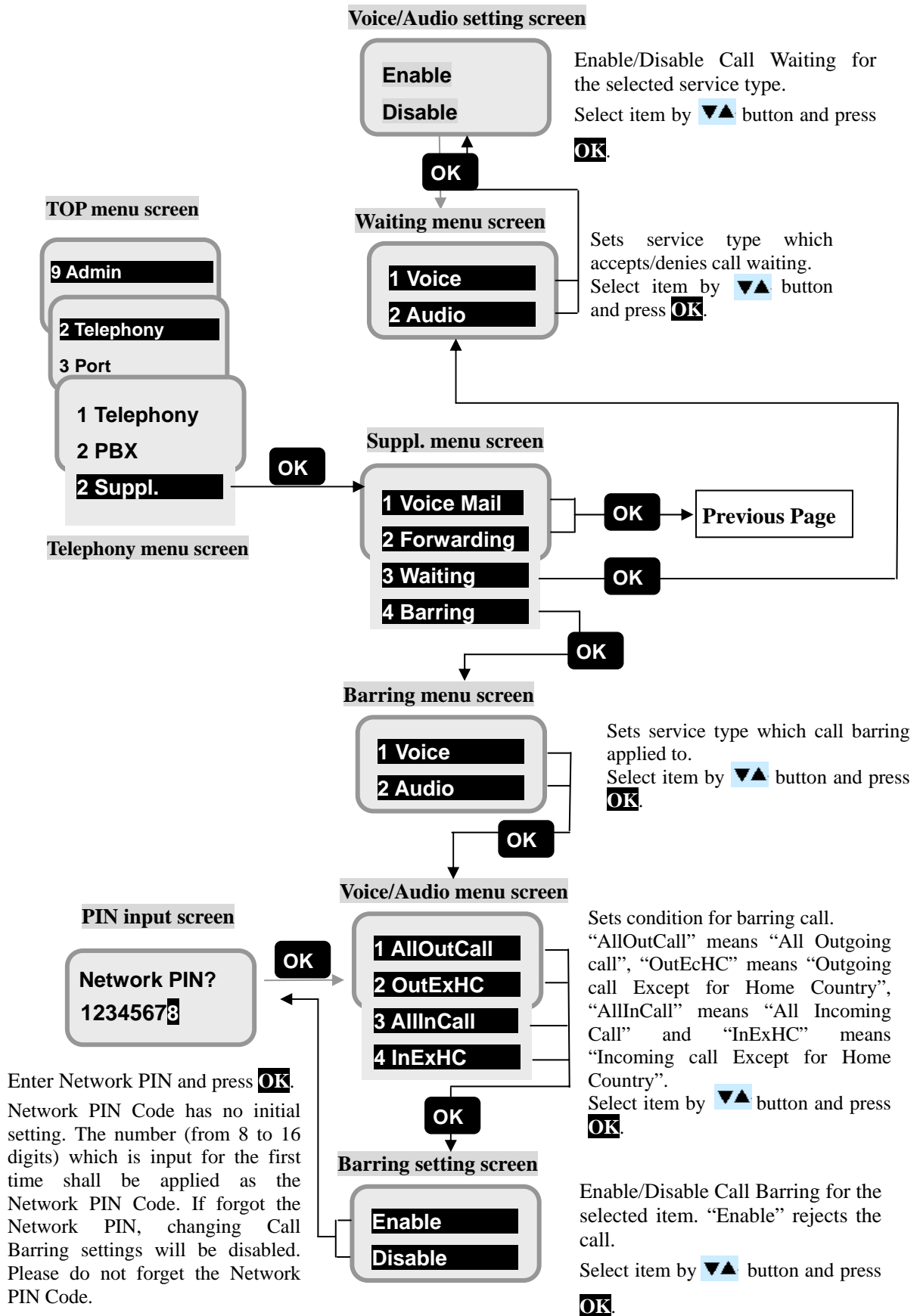

Fig 7.9.2.3b Flow of Waiting /Barring setting screen

7.9.3 Port menu(**MENU** + **9** + **3**)

In this menu, the user can set the advanced setting of Handset, ISDN port, Ethernet port, I/O port and Option port.

1. Handset (7.9.3.1)
 - Selecting brightness of Back Light
 - Selecting LED brightness
 - Selecting pattern of ringer type and volume
 - Selecting loudness of voice volume
 - Setting ON/OFF of key click sound
2. ISDN (7.9.3.2)
 - Assigning Multiple Subscriber's Number (MSN)
3. Ethernet (7.9.3.3)
 - Assigning User LAN IP address
 - Setting ON/OFF of DHCP function
 - Assigning Ext WAN IP address
4. I/O (7.9.3.4)
 - Output a ring indication to the port
 - Input a ring acknowledgement from the port
 - Enable/Disable the I/O port
5. Option (7.9.3.5)
 - Enable/Disable voice distress button
 - Enable/Disable option buzzer connected to Junction Board

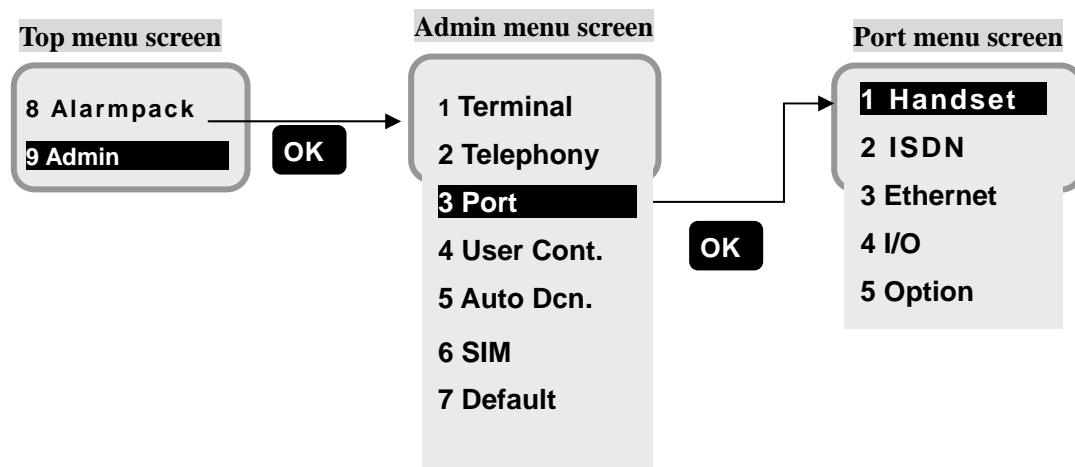

Fig. 7.9.3 Port menu screen

7.9.3.1 Handset advanced setting (MENU+9+3+1+1 to 6)

In this menu, the user can set the advanced settings of Handset (brightness of LCD screen backlight/LEDs, volume /pattern of ringer tone, voice volume, and key click sound).

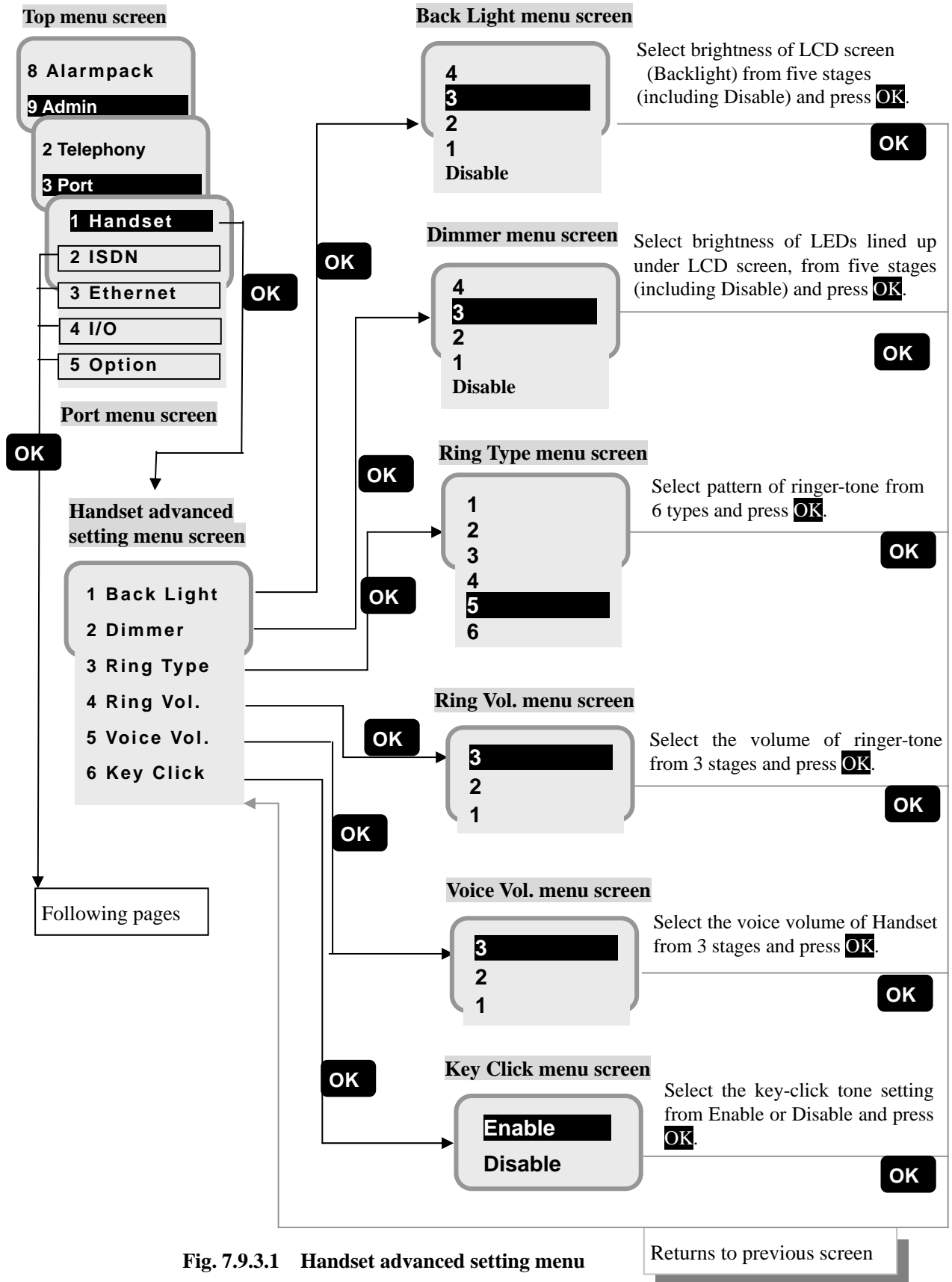

Fig. 7.9.3.1 Handset advanced setting menu

7.9.3.2 ISDN MSN setting

(MENU+9+3+2+1)

In this menu, the user can set the MSN of ISDN port.

MSN:
Multiple Subscriber Number

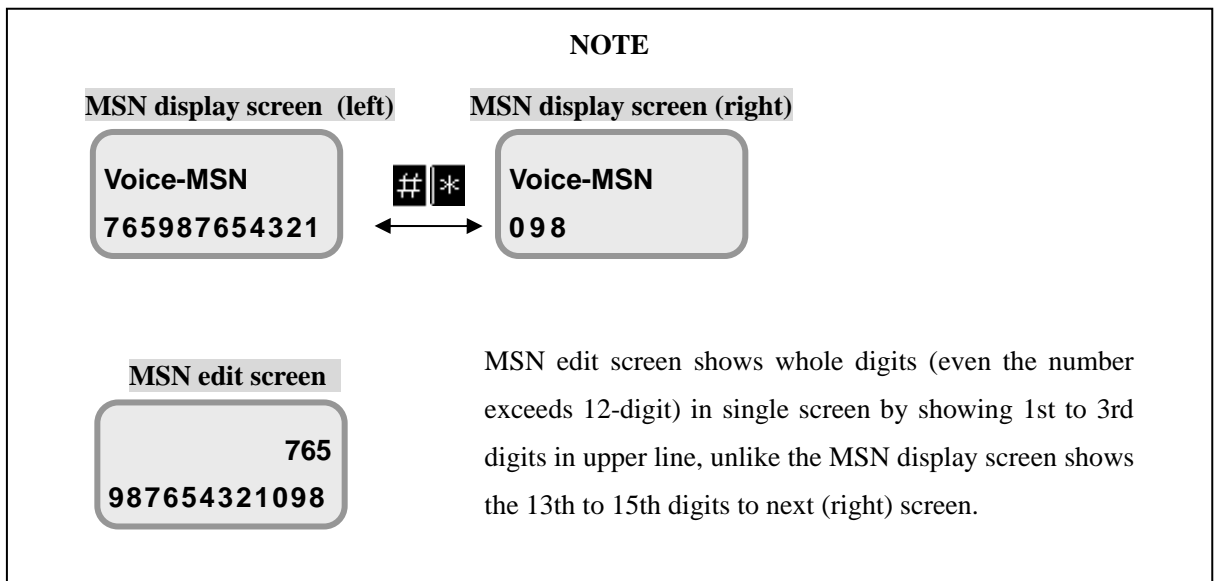
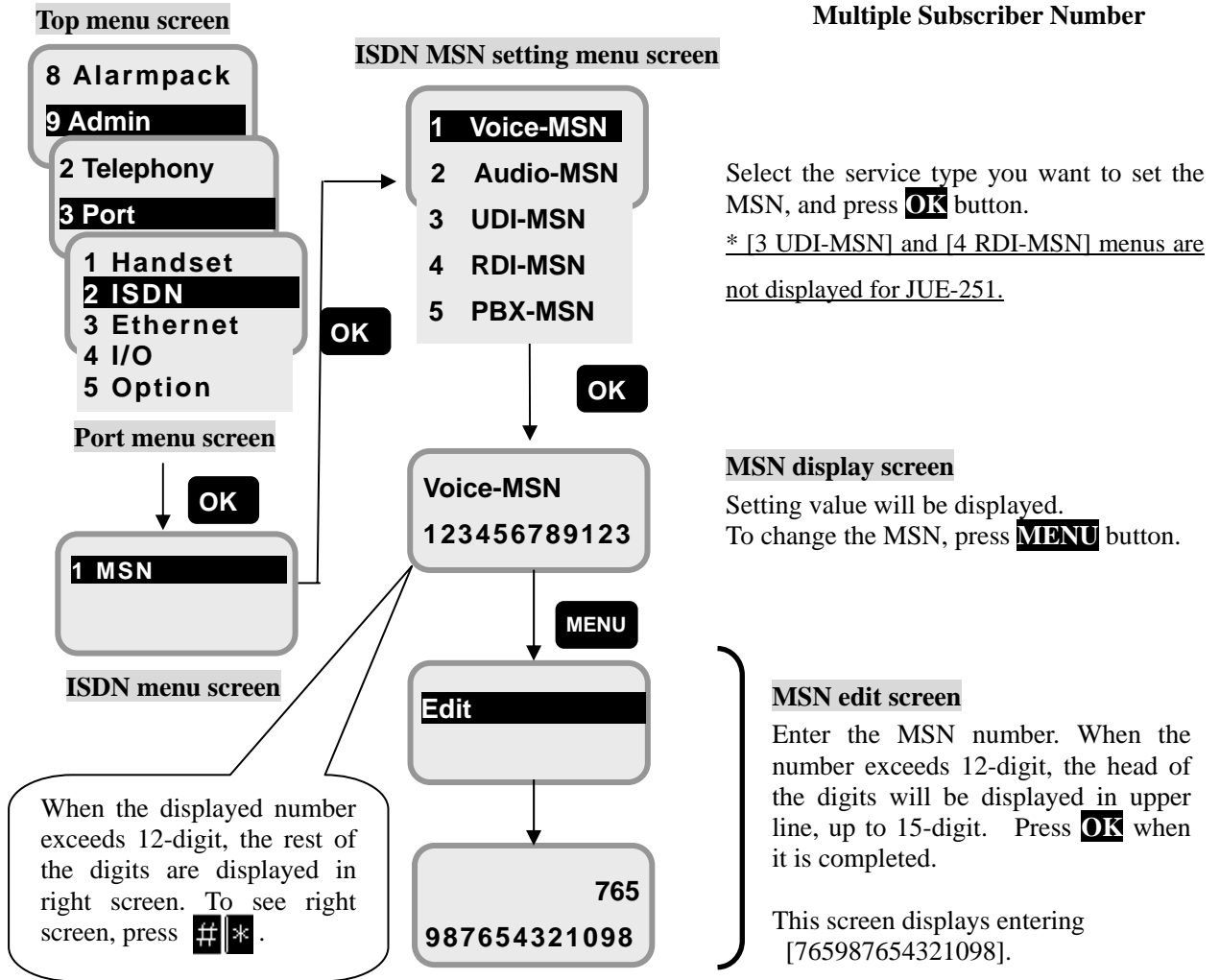

Fig. 7.9.3.2 ISDN MSN setting menu

7.9.3.3 Ethernet (User LAN / EXT WAN) setting

(MENU)+9+3+3+1~2)

A simple User LAN Setting and Ext WAN setting are executed on this menu.

The setting of User LAN registered here is reflected to VLAN1. For further information about VLAN, refer to [6.5.5.6 Further Setting for User LAN (p6-66)]. A maximum of total 32W PoE (Power over Ethernet) is available on User LAN.

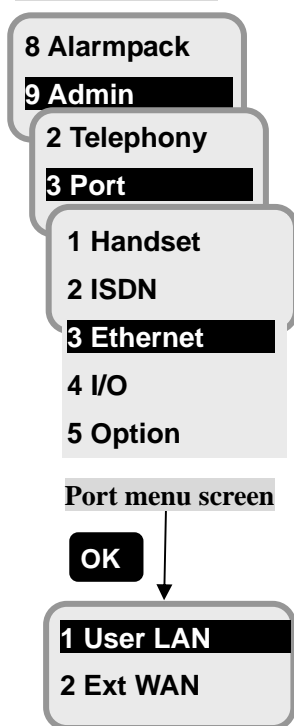
User LAN Setting**TOP menu screen****Ethernet menu screen****IP address ^{*1)} editing screen**

Press any numeric key, then initially displayed numbers are once erased altogether.

Then enter the new IP address and press **OK** button.

Subnet Mask editing screen

Set the SUBNET MASK and press **OK** button.

DHCP setting screen

Set the DHCP function use/non-use.

Select [Enable (use DHCP)] or [Disable (non-use DHCP)] by the cursor and press **OK** button.

DHCP ^{*2)} allocation setting screen

Enter the minimum IP address for the DHCP allocation and press **OK** button.

DHCP ^{*2)} range setting screen

Enter the total amount of the IP address number for the DHCP allocation and press **OK** button. Input the number from 1 to 254.

For default settings, refer to Table 7.9.3.3

***1) About IP address input**

IP address is configured with 4 strings of 3 digits numbers, which delimited by a period.

Add [0] or [00] for the string which is less than 3 digits.

Ex.) [192.168.128.1] shall be input as [192168128001]

Possible input range of IP address:

10. 0.0.1 – 10.255.255.254

172.16.0.1 – 172.31.255.254

192.168.0.1 – 192.168.255.254

Use of “all ones” or “all zeros” for the host field of the IP address is not supported.

***2) About DHCP function**

. Maximum number for the [DHCP range setting screen] is [254].

Fig 7.9.3.3a Flow of User LAN setting

7. Handset Menu System

Ext WAN means external WAN other than FBB system like VSAT. Setting of Ext WAN is necessary for using WAN Selector function. Refer to [6.5.5.9 Coexistence with Other WAN (p6-71)] for WAN Selector.

Ext WAN Setting

TOP menu screen

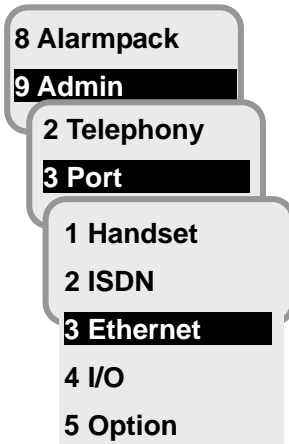

Port menu screen



Ethernet menu screen

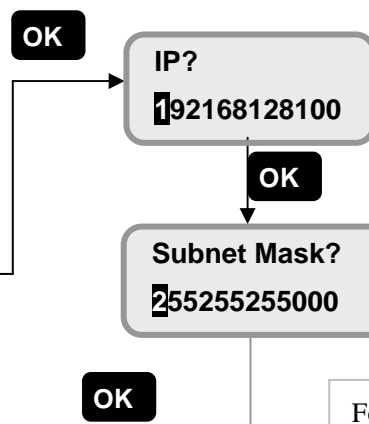

IP address ^{*1)} editing screen

Press any numeric key, then initially displayed numbers are once erased altogether. Then enter the new IP address and press **OK** button.

Subnet Mask editing screen

Set the SUBNET MASK and press **OK** button.

For default settings, refer to Table 7.9.3.3

*1) About IP address input

IP address is configured with 4 strings of 3 digits numbers, which delimited by a period. Add [0] or [00] for the string which is less than 3 digits.
Ex.) [192.168.128.1] shall be input as [192168128001]

Possible input range of IP address:

10. 0.0.1 – 10.255.255.254
172.16.0.1 – 172.31.255.254
192.168.0.1 – 192.168.255.254

Use of “all ones” or “all zeros” for the host field of the IP address is not supported.

Fig 7.9.3.3b Flow of Ext WAN setting

Table 7.9.3.3 Initial Setting for Ethernet Port

Port	Parameter	Value
User LAN	IP	192.168.128.100
	Subnet Mask	255.255.255.0
	DHCP	Enable
	DHCP Base	192.168.128.101
	DHCP Count	16
Ext WAN	IP	192.168.0.4
	Subnet Mask	255.255.255.0

7.9.3.4 I/O setting

(MENU+9+3+4+1~3)

In this menu, user can set input/output of ring acknowledgement/indication from/to the device connected to the Junction Board.

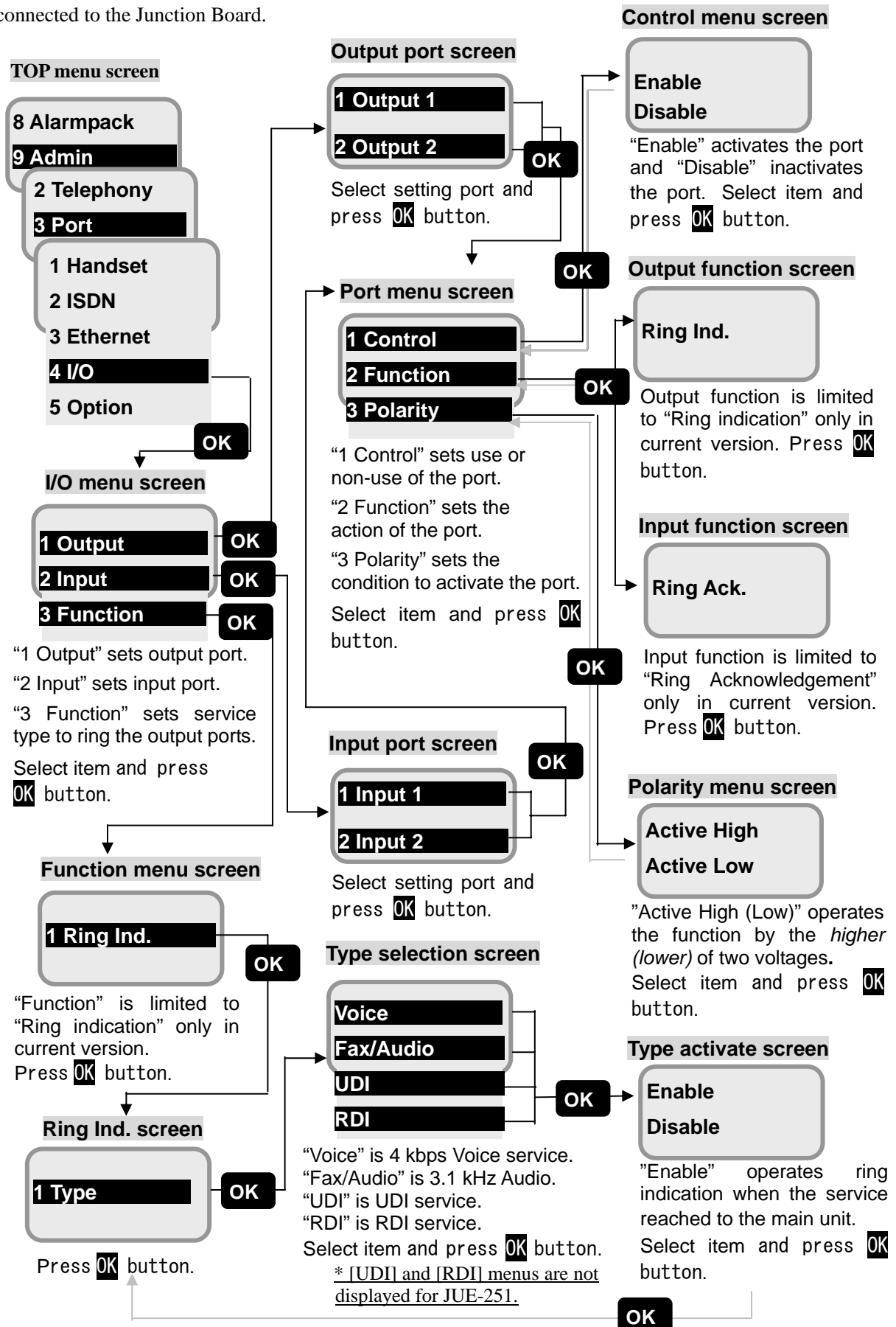

Fig 7.9.3.4 Flow of I/O setting

7.9.3.5 Option setting

(MENU+9+3+5+1~2)

In this menu, the user can set Option Buzzer.

Option Buzzers are connected to the Junction Board and ring when a set service call arrived to the main unit. System reboot is required to change these settings.

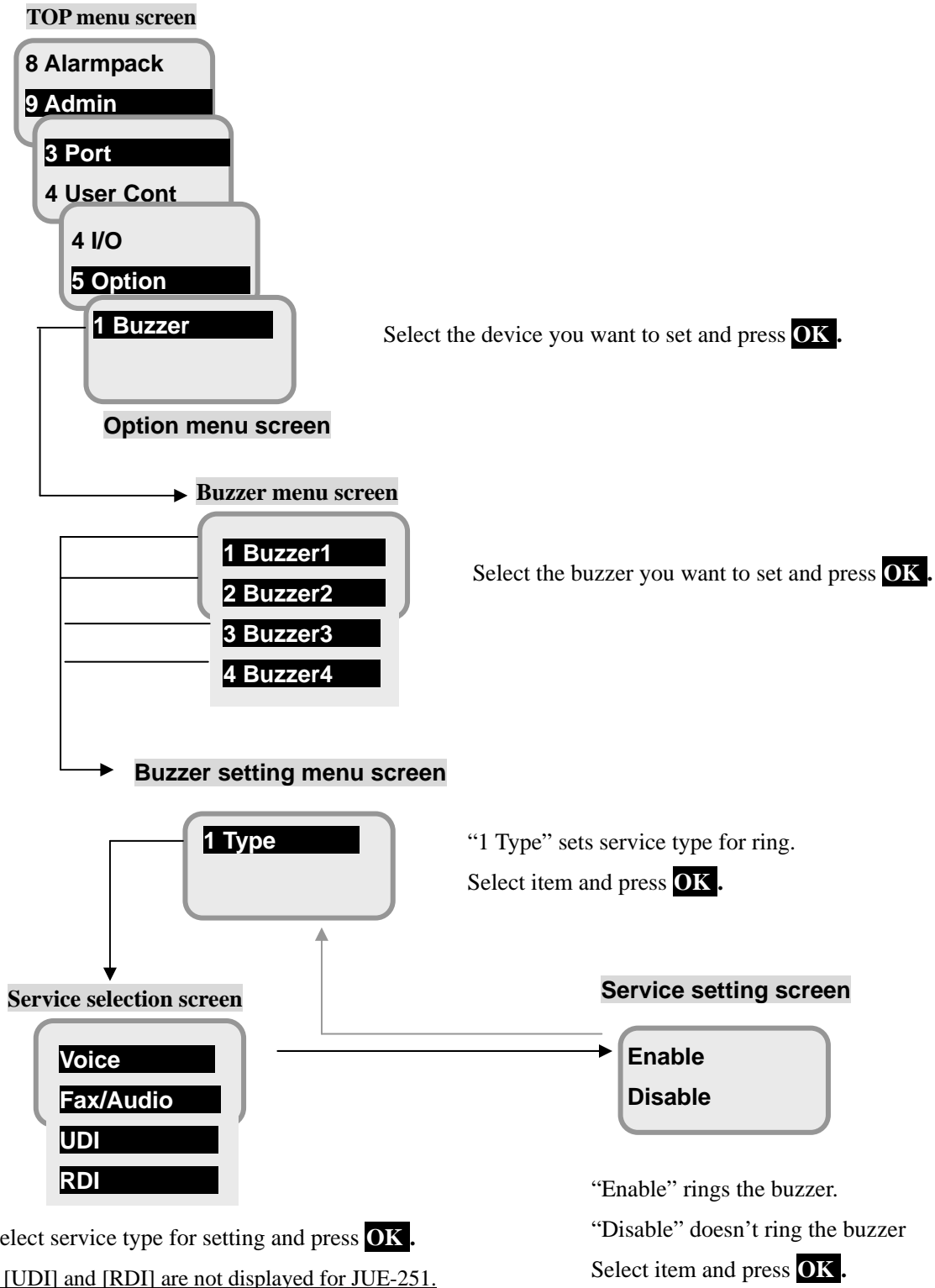

Fig 7.9.3.5 Flow of Buzzer setting

7.9.4 User Cont. menu

(**MENU**+**9**+**4**)

In this section, user registration and usage restriction is described.

7.9.4.1 User Reg. setting	Register new user, edit existing user and delete user. Maximum 50 users can be registered.
7.9.4.2 Usage Rest. setting	Set five Restriction group for communication. User can communicate within limitation of assigned Restriction group. This setting is used in [7.9.4.1 User Reg. setting (p7-61)].

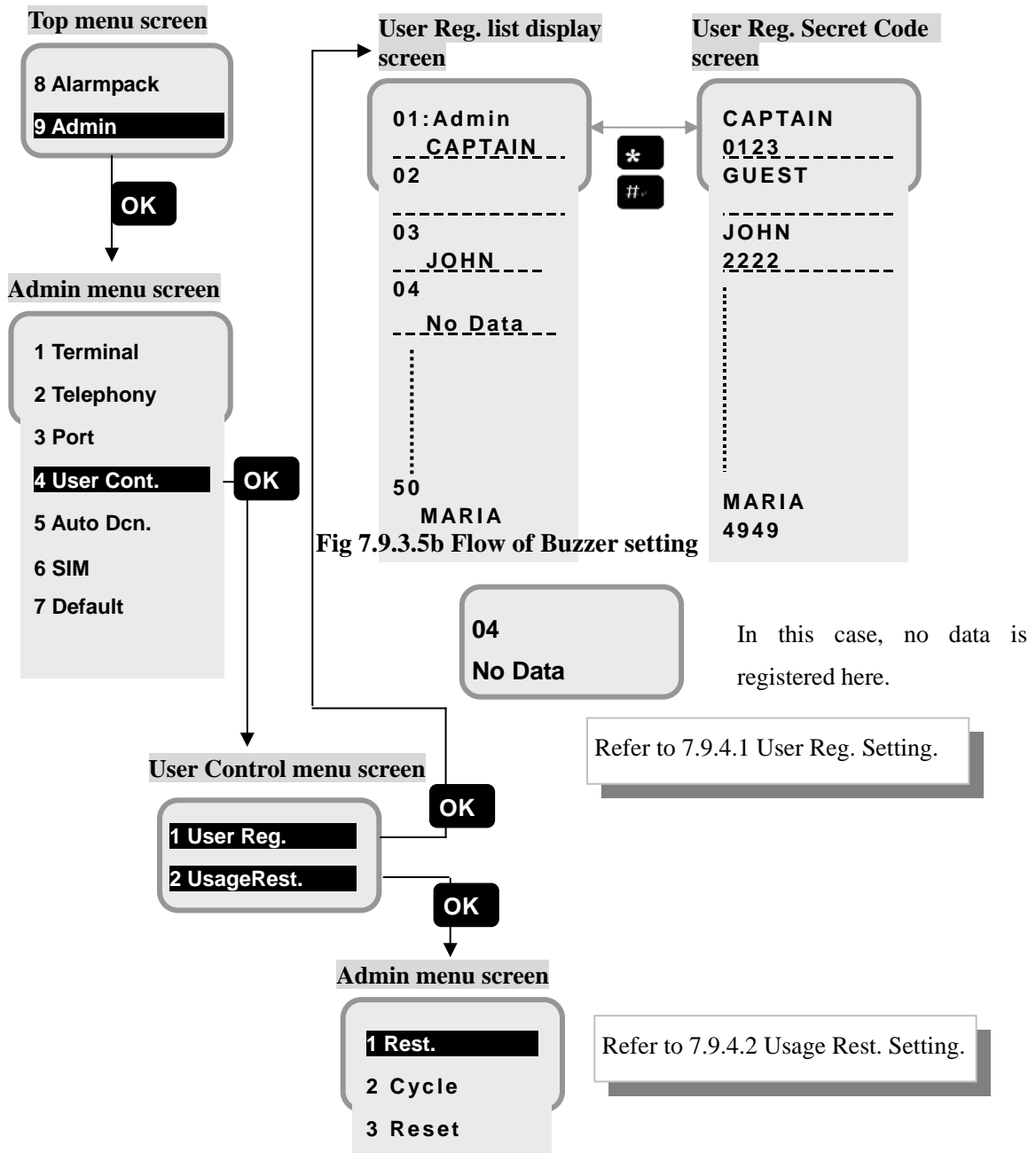

Fig 7.9.3.5b Flow of Buzzer setting

Fig. 7.9.4a User Reg. menu screen transition

7.9.4.1 User Reg. setting

(**MENU**+**9**+**4**+**1**)

To register, edit, or delete the User level, name, Secret Code and restriction, press **MENU** with [User Reg. list display screen] or [User Reg. Secret Code screen] displayed (enter 4-digit Secret Code).

[Registering new user]

Example) Registering a new user MARK with his secret code 1131 on No.04.

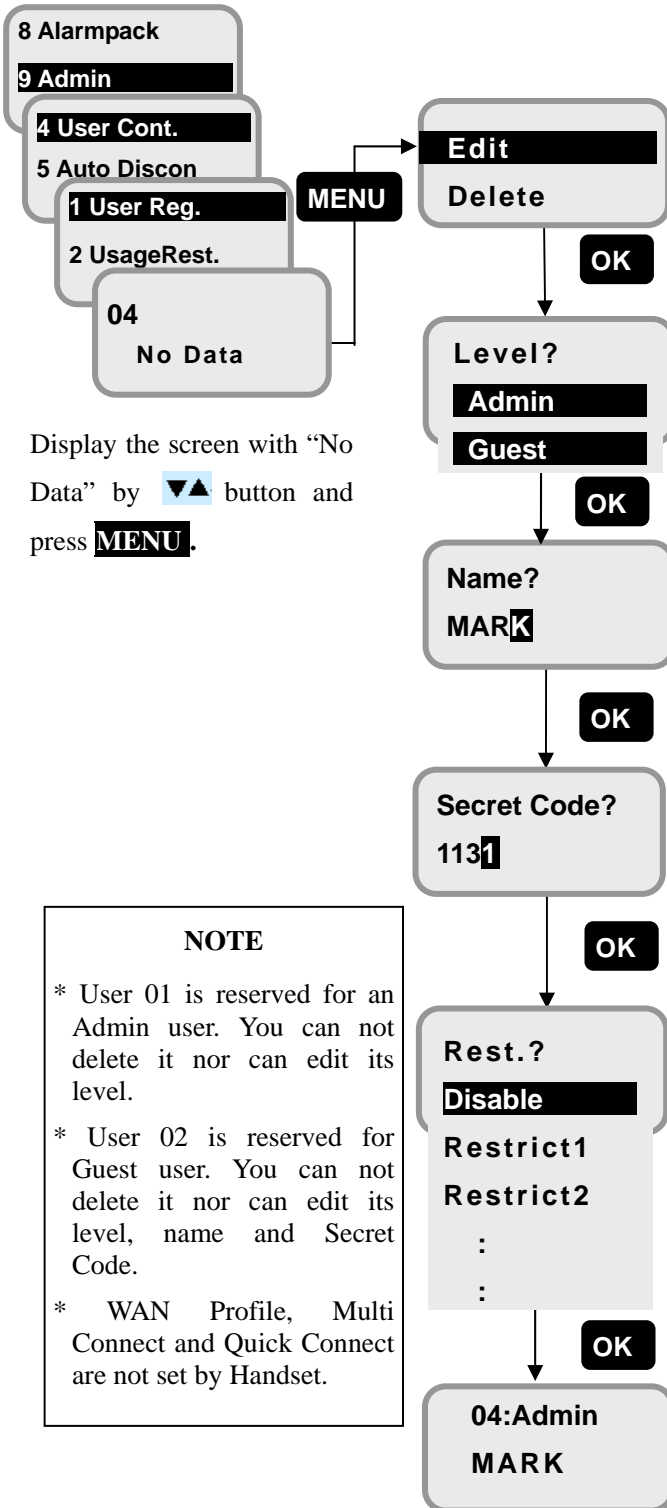

User Reg. operation selection screen

Select [Edit] and press **OK**.

User Reg. Level selection screen

Select level and press **OK**.

User Reg. User Name editing screen

The cursor is blinking at the head of the line.

Enter User name and press **OK**.

To delete the character press **CLR**.

User Reg. Secret Code editing screen

The cursor is blinking at the head of the line.

Enter 4digits Secret Code and press **OK**.

Input range: 0001 to 9000.

To delete the character press **CLR**.

User Reg. Rest. selection screen

Select the restriction applied to the user and press **OK**.

The list shown here are the restrictions preset by user. Refer to [7.9.4.2 Usage Rest. setting] for detail.

“Disable” sets no restriction.

User Reg. list display screen

Newly entered name and Secret Code are stored firmly now.

Registrations finished.

Fig.7.9.4.1a Flow of new user registration

[Edit User name and/or Secret Code]

Even when one item is to be changed, edit screens of all items are displayed. On the edit screen where change is not necessary, just press **OK** button and go to the next screen.

Example) Changing the Secret Code of MARK (No.04), from 1131 to 8765.

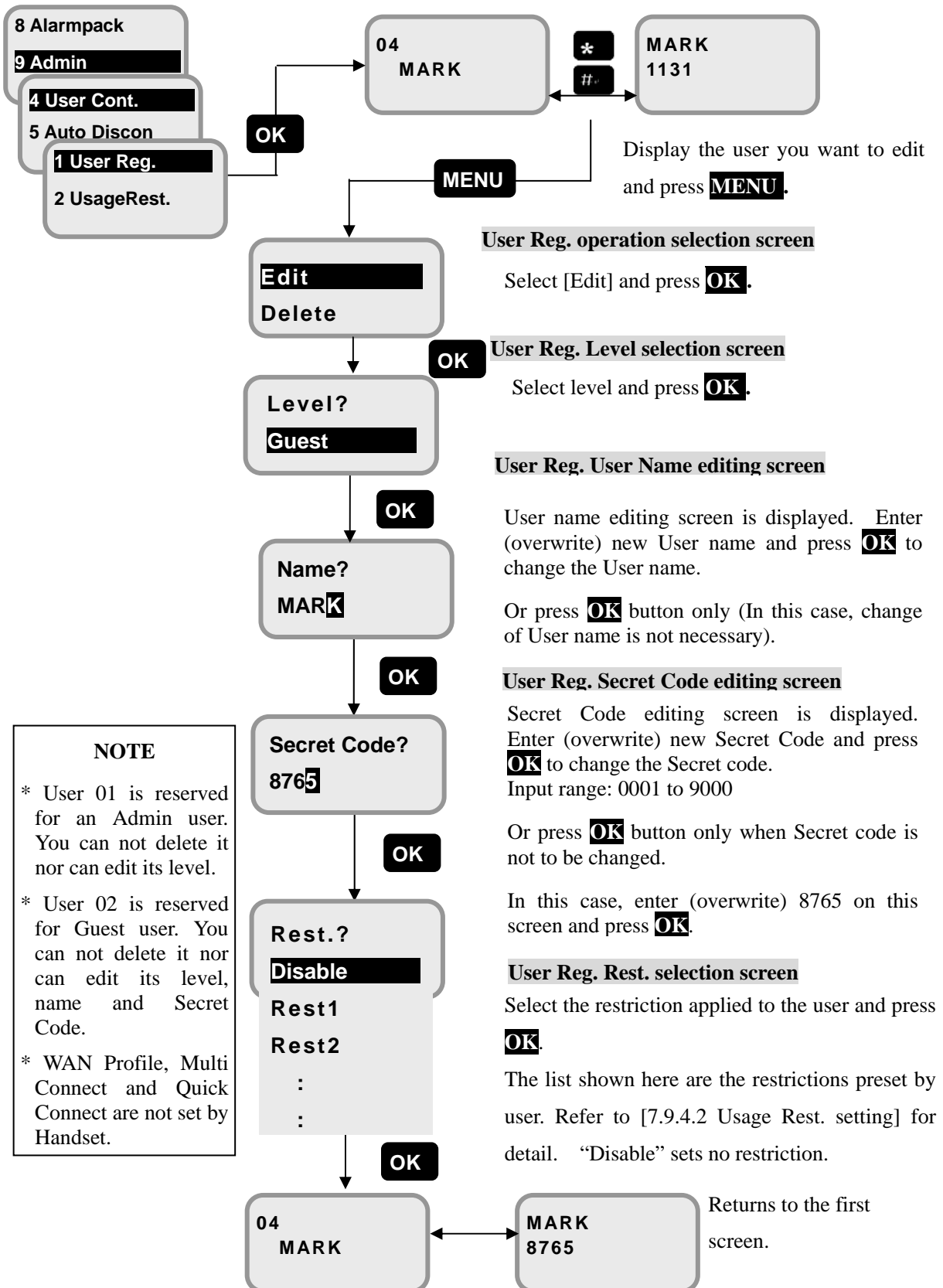

NOTE

- * User 01 is reserved for an Admin user. You can not delete it nor can edit its level.
- * User 02 is reserved for Guest user. You can not delete it nor can edit its level, name and Secret Code.
- * WAN Profile, Multi Connect and Quick Connect are not set by Handset.

Fig. 7.9.4.1b Overwriting procedure of User name and

[Deleting User]

Example) Deleting the data of No.04

Press **MENU** with the User Reg. list which displays No.04.

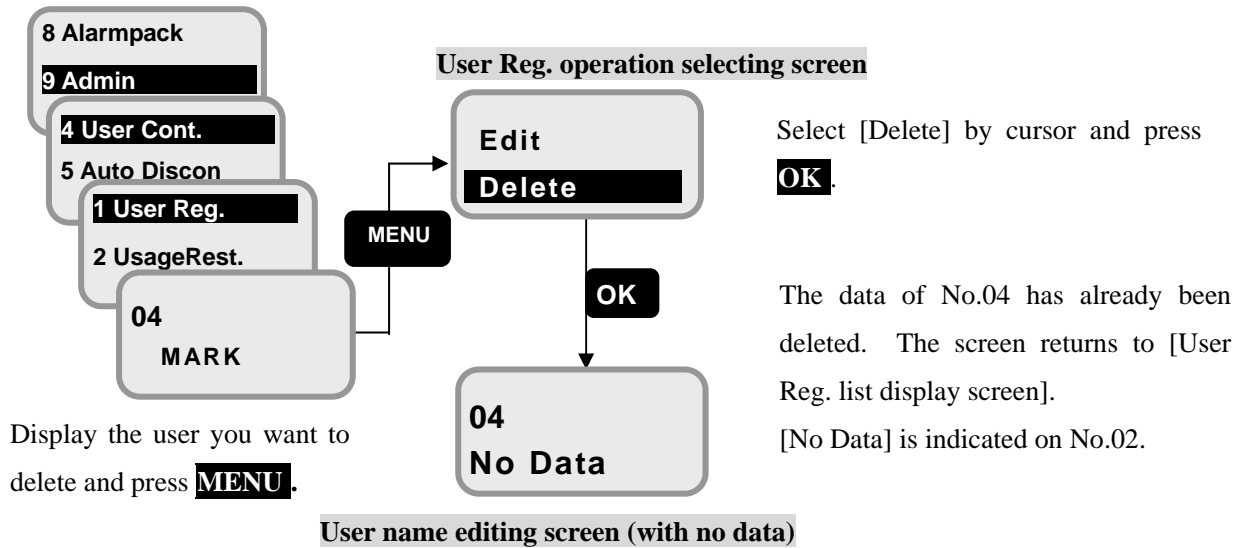

Fig. 7.9.4.1c Deleting User

NOTE

- * Beware that once the data is deleted, it won't be recovered again.
- * User 01 is reserved for an Admin user. You can not delete it nor can edit its level.
- * User 02 is reserved for Guest user. You can not delete it nor can edit its level, name and Secret Code.

7.9.4.2 Usage Rest. setting

(MENU+9+4+2+1~3)

Set Restriction group for communication up to five. The limitations are made by time (minutes) for Voice, Audio, UDI, RDI and Streaming IP service, by number for SMS and by size (Mbyte) for Standard IP service. User can communicate within the assigned restriction. These settings are used in [7.9.4.1 User Reg. setting (p7-61)]. Select the cycle to clear up the counting time and traffic from “Manually”, “Monthly”, “Weekly” or “Daily”.

[Setting a Usage Restriction group]

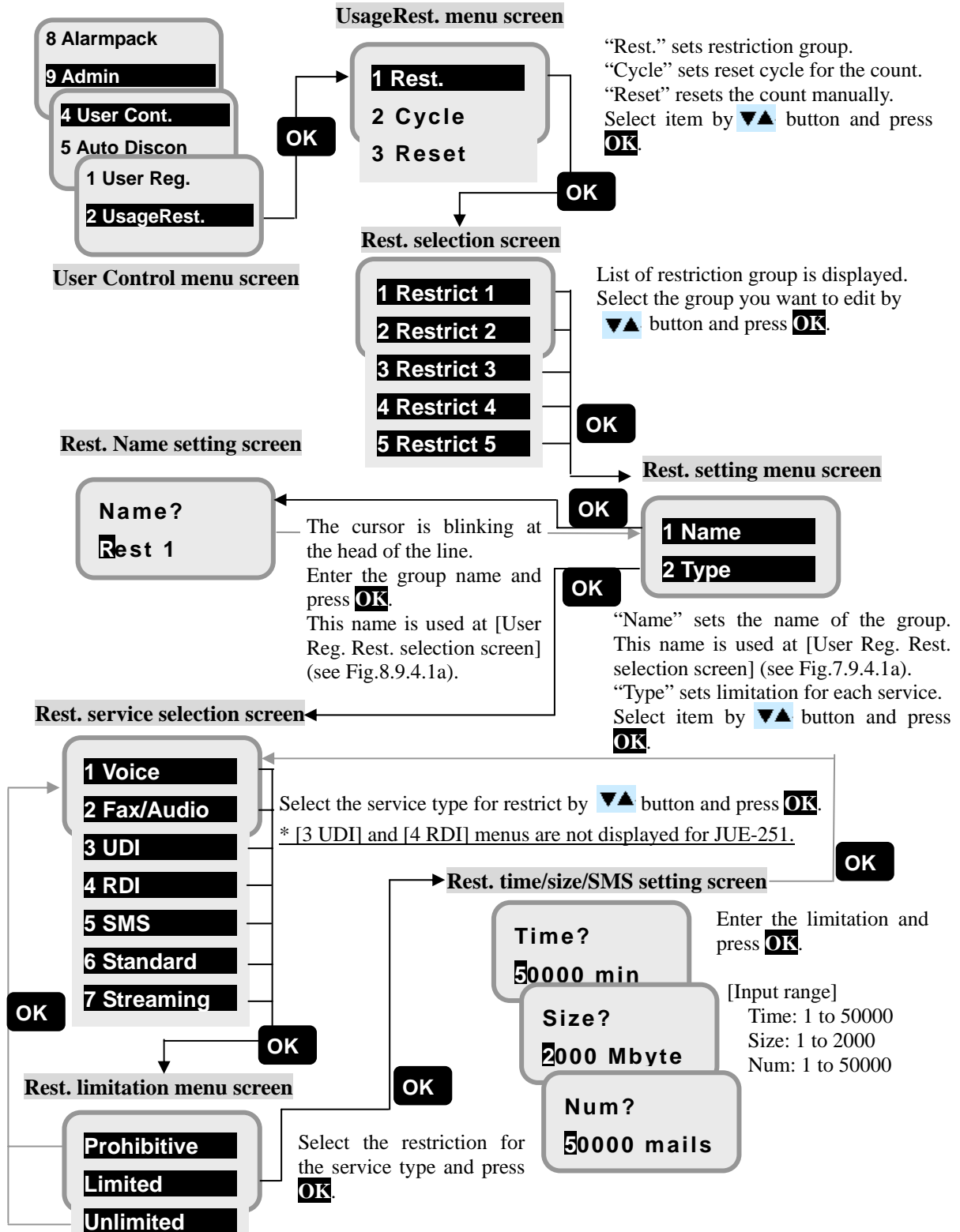

Fig. 7.9.4.2a Flow of Usage Restriction group setting

[Setting Clear up Cycle]

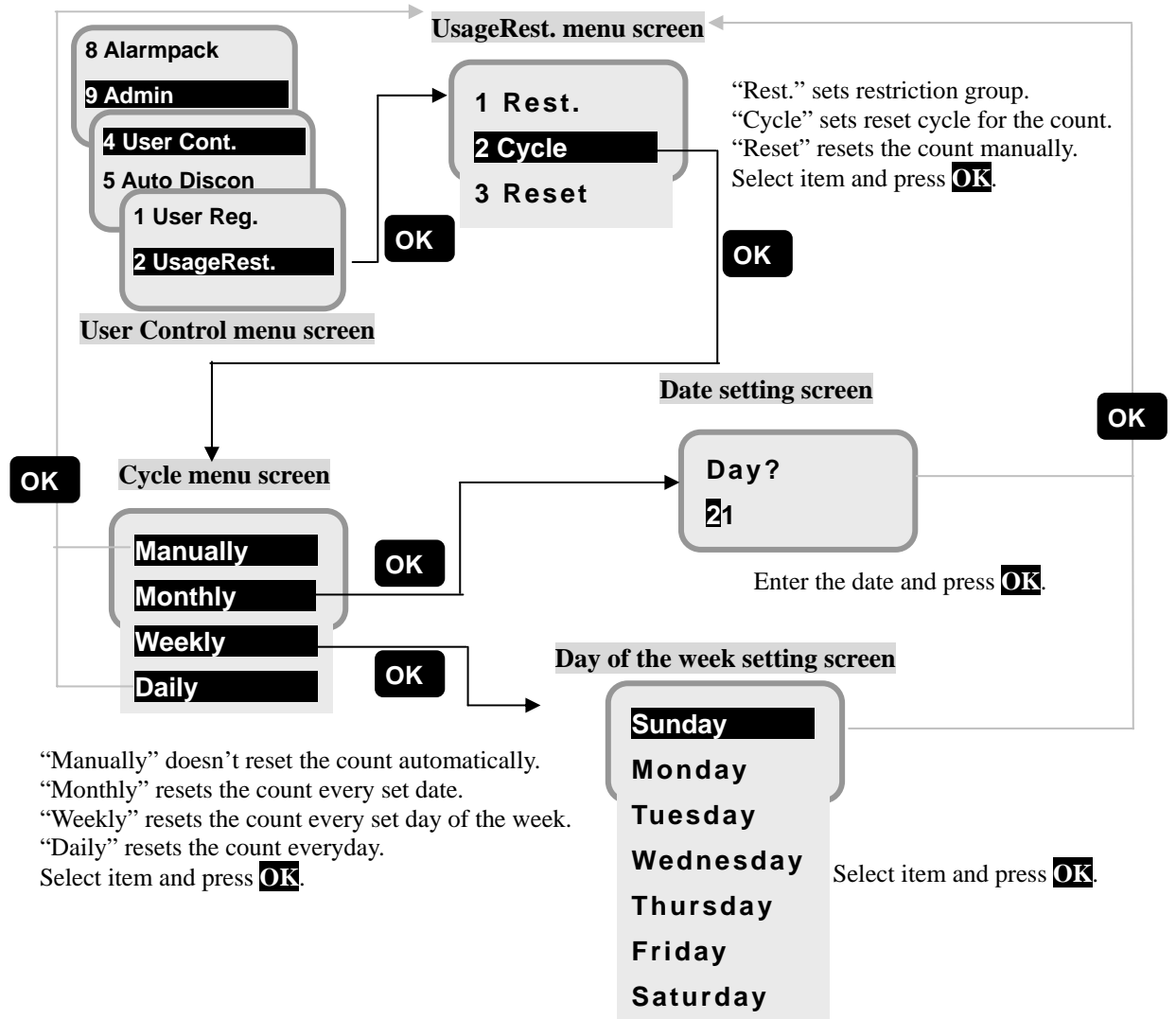

Fig. 7.9.4.2b Flow of Reset Cycle setting

[Reset the Count Manually]

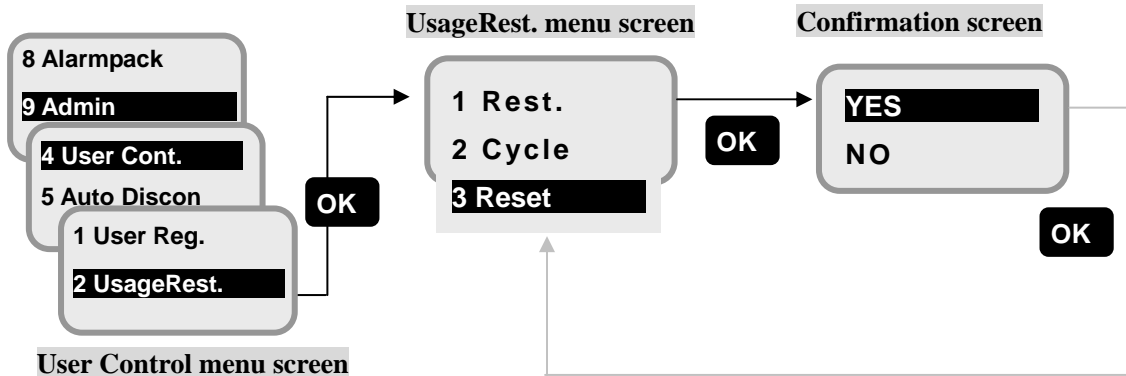

Fig. 7.9.4.2c Flow of Resetting the Count Manually

7.9.5 Auto Dcn.(Auto disconnection) menu**([MENU]+ 9 +5)**

In this menu, user can set the auto disconnection time (Max Time / Idle Time).

Select [5. Auto Dcn.] menu from [Admin] menu. This menu is useful to prevent a user from accidentally forgetting to disconnect the line.

Setting of Max Time (Max connection time) is for the automatic disconnect of Handset, TEL1~6, ISDN, Streaming IP and Standard IP communication. Terminal will automatically disconnect the communications according to the settings with regardless of its communication state.

Setting of Idle Time (Idle connection time) is for the automatic disconnect of Standard IP communication. Terminal will automatically disconnect the communication by monitoring the Idle time.

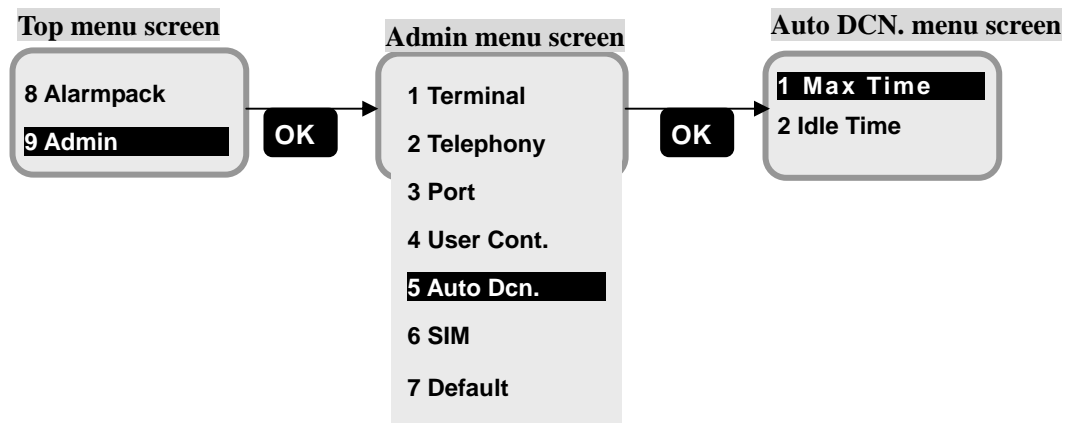

Fig. 7.9.5 Sequence of opening Auto Dcn. menu screen

Note

- Distribution partner of SIM card might charge a communication fee by only connecting and disconnecting Standard IP Connection.
- Auto Disconnect function never disconnects PS Connection connected by Always Activate function. Thus PS Connection connected by Always Activate function keeps the connection active.

7.9.5.1 Max Time setting

(**MENU**+**9**+**5**+**1**+**1**~**9**)

Setting screen of Max Time (max connection time limit) is displayed when service type is set at [Max Time menu] screen. Time unit is minute and the range is 0-240min. Set “0min.” when unlimited connection is required. Enter 1 to 3-digit number and then press **OK**. Then the screen returns to previous one. To delete the digit, press **CLR**.

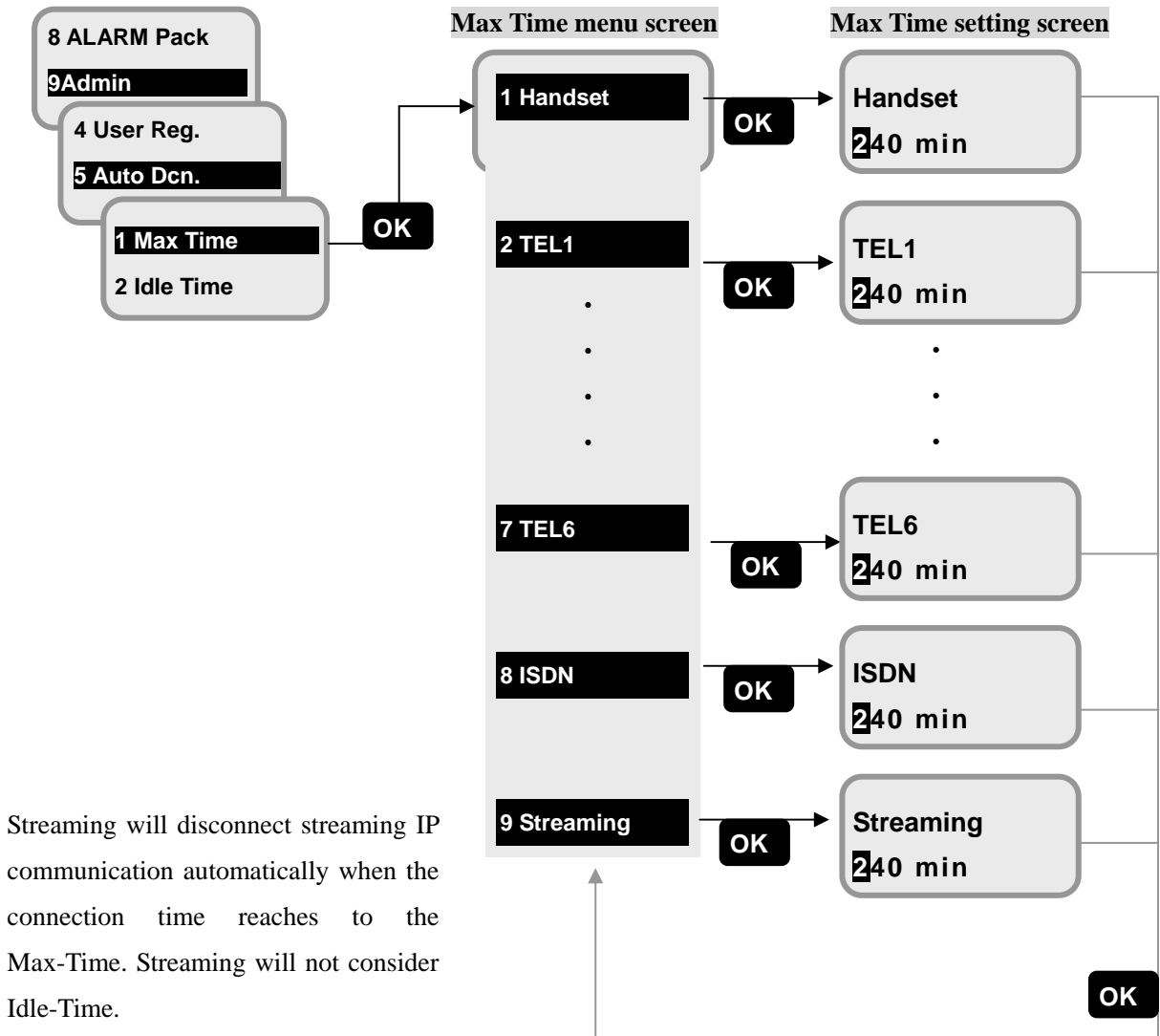

Streaming will disconnect streaming IP communication automatically when the connection time reaches to the Max-Time. Streaming will not consider Idle-Time.

Fig. 7.9.5.1 Max Time menu screen and Max Time setting screen

7.9.5.2 Idle Time setting

(**MENU**+ **9** +**5** +**2** +**1**)

Setting screen of Idle Time (idle connection time limit) is displayed when service type is set at [Idle Time menu] screen. Time unit is minute and the range is 1-240min. Enter 1 to 3-digit number and then press **OK**. Then the screen returns to previous one. To delete the digit, press **CLR**.

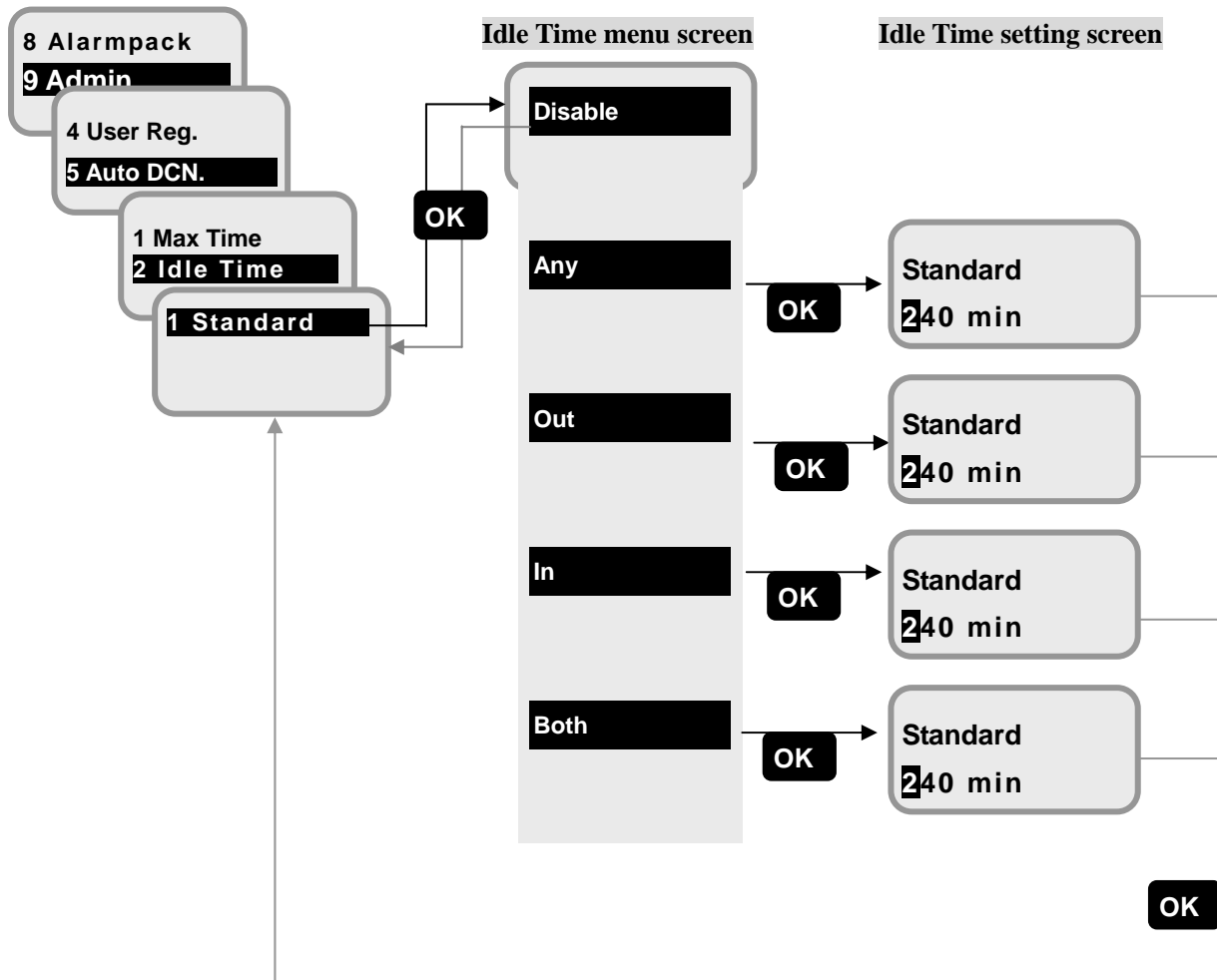

Fig. 7.9.5.2 Idle Time menu screen and Idle Time setting screen

Disable: It does not disconnect Standard IP connection automatically

Any: It disconnects Standard IP connection by the setting-time regardless of the existence of any packet data.

Out: It disconnects Standard IP connection by monitoring the upload idle time

In: It disconnects Standard IP connection by monitoring the download idle time

Both: It disconnects Standard IP connection by monitoring the upload and download idle time

7.9.6 SIM Menu

(**MENU**+**9**+**6**)

In this menu, user can set up the items of SIM card.

The [SIM Menu screen] is displayed when [6 SIM] is selected from Admin menu.

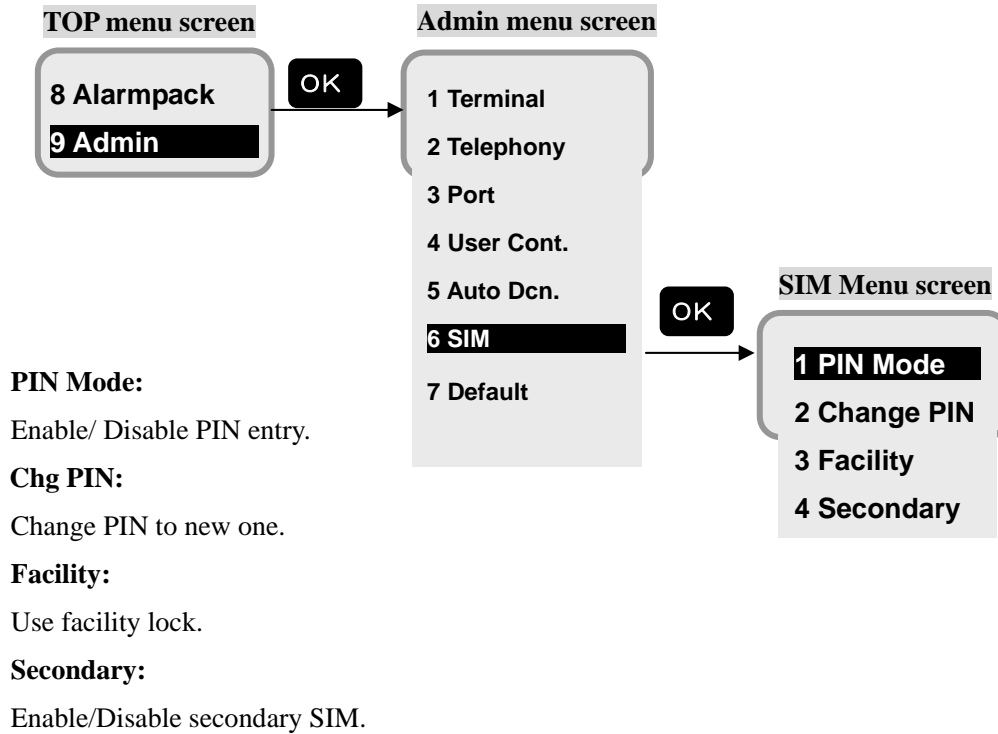

Fig. 7.9.6 SIM Menu screen

Releasing PIN locking and new PIN setting procedure

When the PIN is locked, SIM PUK (Personal Unblocking Key) input screen is displayed.

Input 8-digits of SIM PUK which you obtained at purchasing SIM card.

(If the input error of SIM PUK is occurred 10 times continuously, the SIM card is invalid.)

The screen transition hereafter is the same as **PIN changing procedure (7.9.6.2 Chg PIN setting)**.

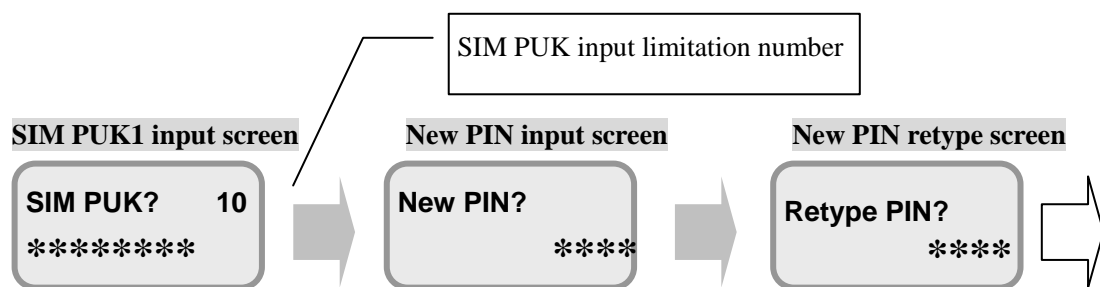

Fig. 7.9.6.2b Releasing PIN locking and new PIN setting procedure

7.9.6.4 Secondary SIM setting

MENU+9+(6+4)

In this menu, the use or non-use of Secondary SIM can be set. The Secondary SIM is used for remote maintenance. System reboot is required to change setting.

- 1) Select [4 Secondary] at [SIM Menu screen] and press **OK**, and then select the setting for Secondary SIM. “Enable” uses Secondary SIM instead of user’s SIM.
- 2) To enable the setting, reboot your system.

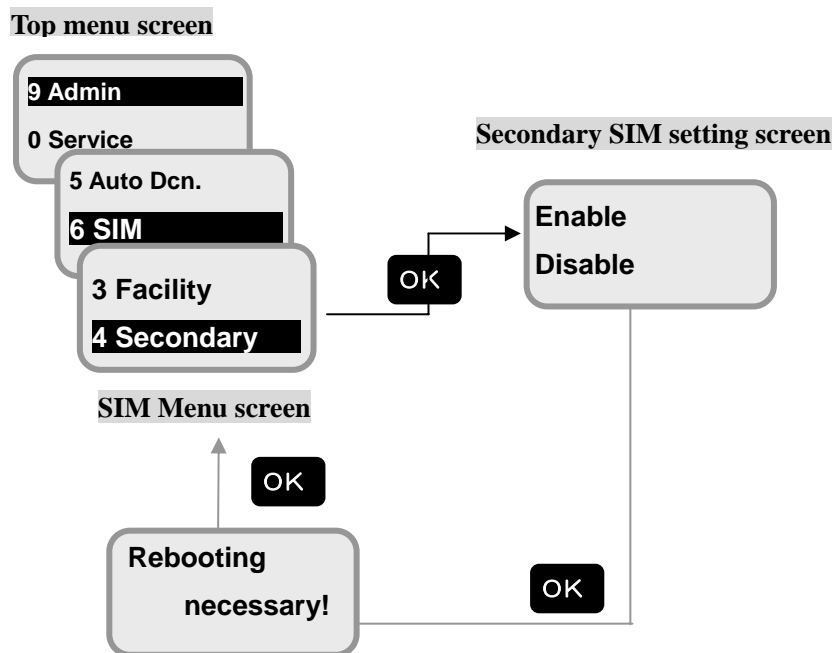

7.9.7 Default menu

MENU+ 9 +7)

In this menu, user can initialize Alarmpack and Flash to the factory default.

The [Default Menu screen] is displayed when [7 Default] is selected from Admin menu.

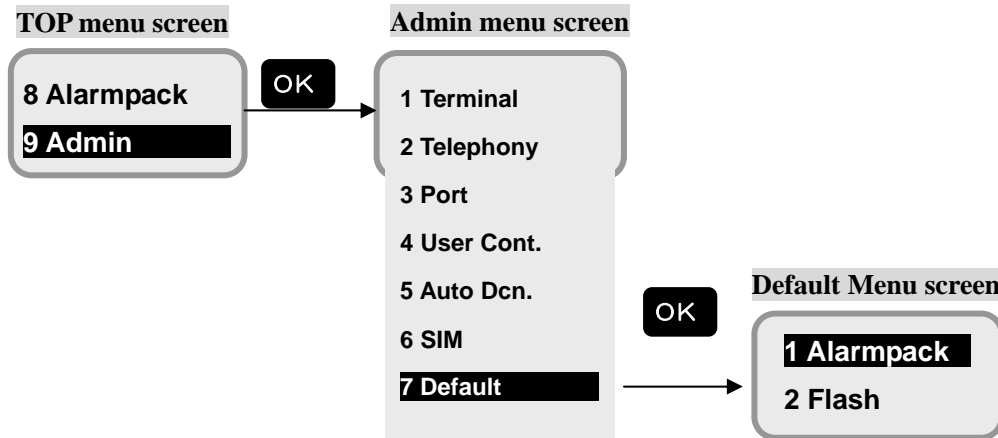

Alarmpack:

Clear the Alarmpack memory.

Flash:

Clear the Flash memory including user setting and Alarmpack.

Fig. 7.9.6 SIM Menu screen

7.9.7.1 Alarmpack

MENU+9+7+1)

In this menu, user can delete the memory of Alarmpack.

NOTE

Beware that once the data is deleted, it won't be recovered again.

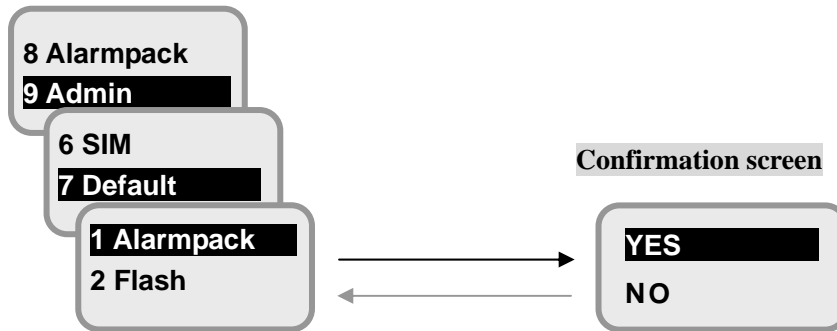
Top menu screen

7.9.7.2 Flash

MENU+9+7+2)

In this menu, user can delete the flash memory including user setting and Alarmpack. JUE-501/JUE-251 will be reset to the factory default. System reboots automatically when [YES] is selected on [Confirmation screen].

NOTE

Beware that once the data is deleted, it won't be recovered again.

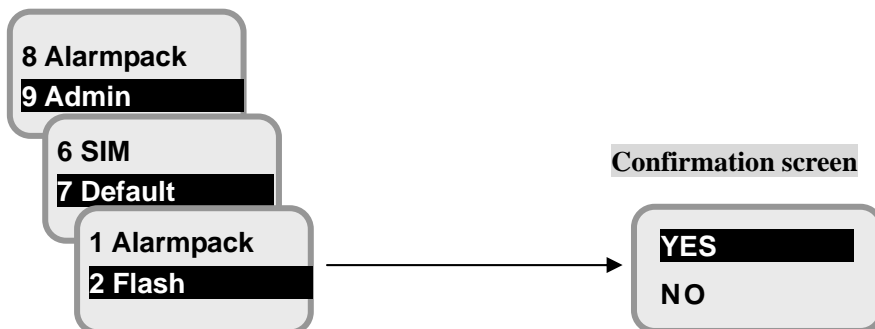
Top menu screen

7.10 Other screen

(Short cut is not available)

This screen is displayed when a fault is detected.

TX alarm screen

The screen pops up when TX alarm (the transmission stopped because of a trouble in transmitting system) is generated.

Press **OK** to reset the alarm, the screen returns to [Idle screen].

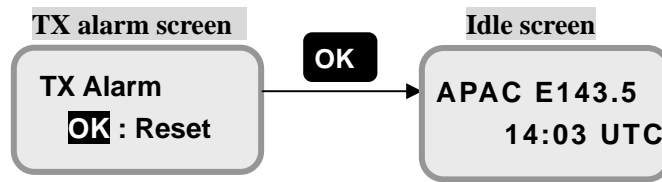

Fig.7.10 TX alarm screen

8. Using ISDN port

In this section, a continued setting for using telephone on ISDN port is explained.

Continued from [4.2 Initial setting for communication (p4-10)]

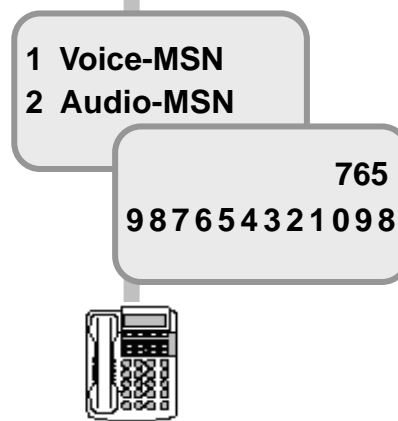

Fig. 8a Setting flow using telephone on ISDN port

ISDN port acts as a ISDN Basic Rate Interface (BRI) Network Termination (NT) and provides a S/T (SO) interface. (Note that only 1B channel (1 call) can be supported at any time). The specification of this port is shown in below table.

Item	Specification
Network Switch Type	Euro ISDN, INS
Coding Type of voice	A-law, μ -law
Max. number of unit	A maximum of 8 TE
Connector	RJ-45 (S/T Interface)
Supported service	-Inmarsat 4kbps Voice -Inmarsat 3.1kHz Audio -UDI -RDI

NOTE

- ISDN port and Ethernet port use the same connector type (RJ-45). Be careful not to connect the wrong port.
- 3.1kHz Audio services like fax is available for JUE-251 only when the satellite elevation angle (EL) is larger than 20 degrees. (Anytime for JUE-501 except for the high latitudes.)
- UDI/RDI service is not available for JUE-251.

8. Using ISDN port

When a TA (Terminal Adapter) originates a call, TA informs the "transfer capability" to JUE-501/JUE-251.

Then JUE-501/JUE-251 determines the transmission service type depending on that information.

This relationship is described in below table:

"Transfer capability" from a TA	Transmission service type determined by JUE-501/JUE251
Speech	Inmarsat 4kbps Voice
Audio	Inmarsat 3.1kHz Audio
UDI	UDI
RDI	RDI

* UDI/RDI service is not available for JUE-251.

When a call arrives to JUE-501/JUE-251, it informs a Multiple Subscriber Number (MSN) programmed by the user to TA. TA can identify an arriving service type using this MSN.

Setup following items:

- (1) MSN of TA with following TA's manual
- (2) MSN of JUE-501/JUE-251 with following below setting procedure.

[Connection sample]

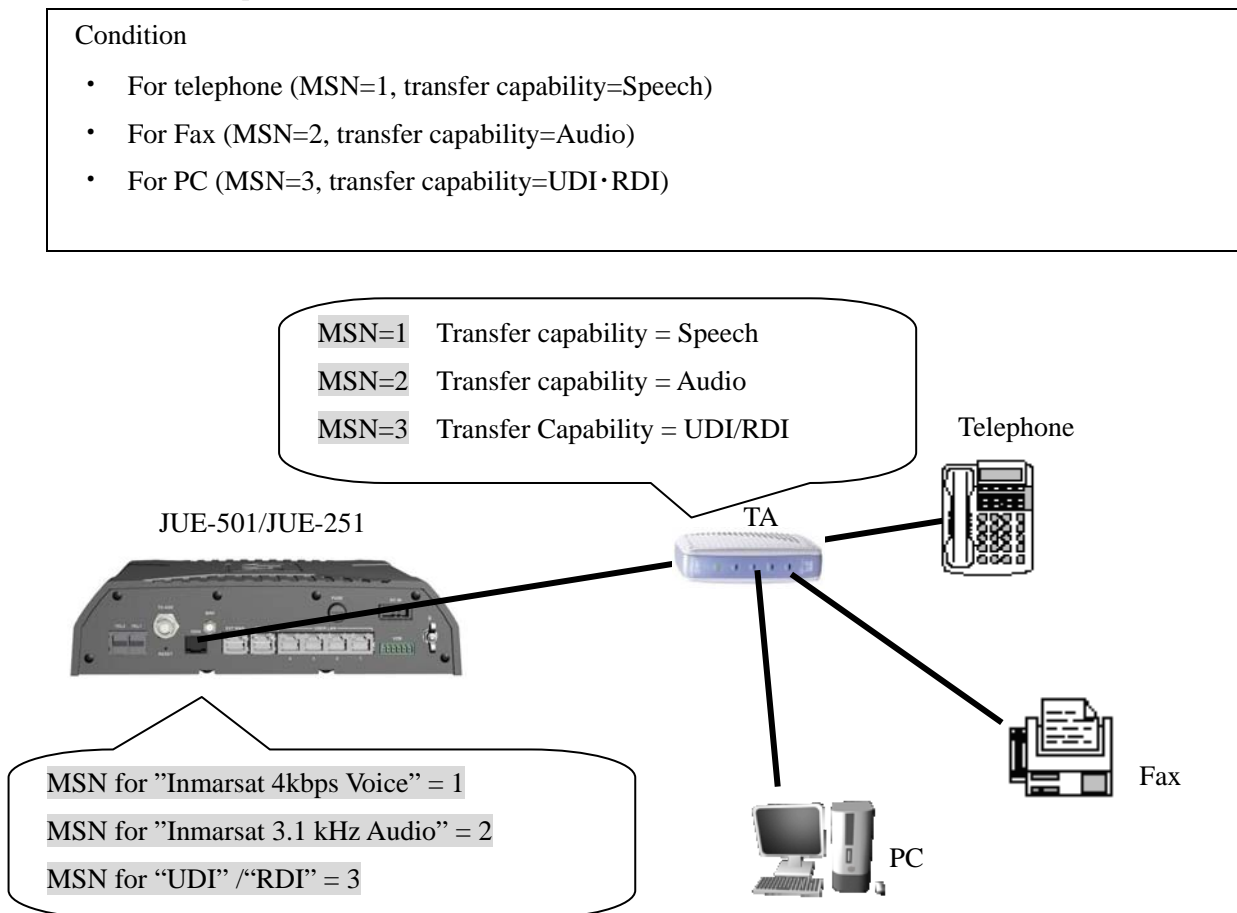

Fig.8b Connection sample of ISDN port

Setting MSN using Handset [MSN edit menu]

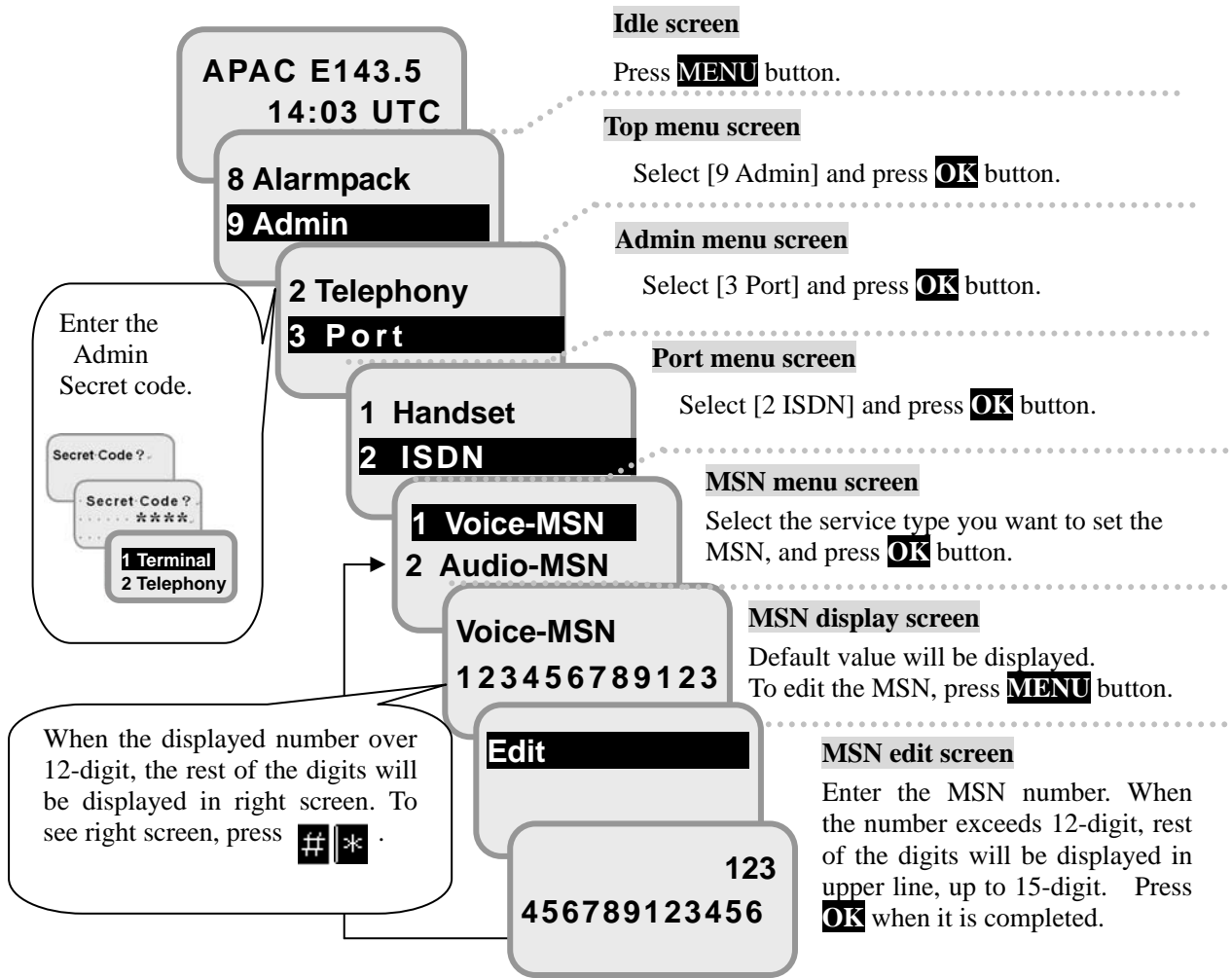

Fig. 8c Flow of Setting MSN using Handset [MSN menu]

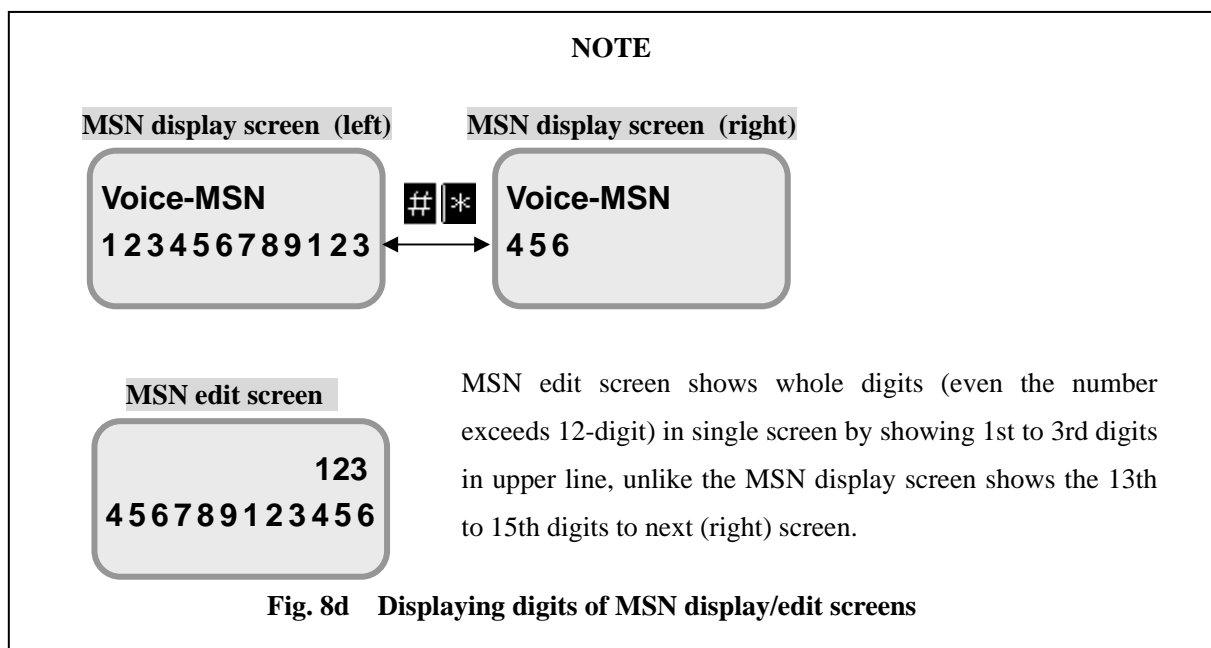

Fig. 8d Displaying digits of MSN display/edit screens

8. Using ISDN port

Setting MSN using Web Menu [MSN edit menu]

To set MSN using Web menu, refer to [Sec. 6.5.3.2 Set MSN and ISDN Service Type (ISDN Screen) (p6-40)].

Dial-up procedure from ISDN port

00 **Country Code** **Area Code** **Subscriber's number** **#**

Example) Placing a call to +81-422-45-9111, in Japan → **0081422459111** **#**

NOTE

Making a call using Secret Code and forced setting service is not supported.

Regarding the Redial calling and the Speed Dialing, it is depending on the specification of your TA.

9. Maintenance

The life of the JUE-501/JUE-251 depends on how well the equipment is maintained. Check the following items from time to time to ensure the best performance of your JUE-501/JUE-251.

- 1) Keep the input voltage within the specified range (+21VDC to +31VDC).
- 2) Record the transmitting power (EIRP) and the receiving level (REC) once at the time when the equipment is in good order. During the operation, compare the EIRP and REC level with the recorded normal values. This deed helps you to remove a fault before it develops into a serious one.

Daily maintenance

The following table shows daily maintenance with general tools.



 <h1 style="margin: 0; font-size: 2em;">WARNING</h1>
<div style="display: flex; align-items: flex-start;"> <div style="margin-right: 10px;">  </div> <div> <p>Do not troubleshoot or repair the internal equipment of the JUE-501/JUE-251 by yourself.</p> <p>Any electrical work by any person other than our trained maintenance staff may cause fire or abnormal operation of this equipment or electrical shock for you. This equipment meets the technical standard of the Ministry of Internal affairs and Communications.</p> </div> </div> <div style="margin-top: 10px;"> <div style="display: flex; align-items: flex-start;"> <div style="margin-right: 10px;">  </div> <div> <p>Do not adjust the internal circuit without a calibrated measuring instrument or exchange the parts because the internal circuit has been adjusted finely to specifications. If the equipment works abnormally, please contact the purchasing dealer.</p> </div> </div> </div>

Table 9.1 Daily maintenance

No.	Item	Maintenance
1	Cleaning	Clean the panel, switch, top cover, and the button cover with a soft cloth.
2	Fastening	Fasten the loose screw, nut, switch, and the connector.

NOTE

Please access the URL below and register customer's information to get detailed technical information and to enable your warranty.

URL: <http://www.registration.msdl.jp/msdroot/FBB/FBB/Page/TopMenu.aspx>

This page is remained as a blank.

10. After-sales service

When ordering repair

When a fault has been detected, refer to the “Appendix L. Trouble shooting and FAQ”. If it is not improved, turn OFF and ON the power switch of main unit to reboot. Still it persists, stop operation and contact the purchasing dealer.

During the guarantee term;

JRC will repair the equipment or exchange any parts proven to be malfunctioning under normal use. The user is requested to have operated the equipment as instructed in the instruction manual.

In the following cases, guarantee service is not accepted.

- Installation report has not been sent to JRC immediately after the JUE-501/JUE-251 was commissioned.
- The equipment has been subjected to accident, abuse, or misuse, shipping damage, alternations, incorrect and/or non-authorized service.
- The trouble, failure, malfunctioning and whatever is due to Act of God, fire, flood, explosion, accident, strikes, labor troubles or other industrial disputes, war (declared or undeclared), armed conflict, civil disturbance, embargoes, blockades, legal restrictions, riots, insurrections or any other cause beyond the control of JRC and the purchaser.

Service out of the guarantee term;

If the function is recoverable by a repair, JRC will arrange a charged service on customer’s demand.

To request a guarantee or non-guarantee service, please inform us of;

+Ship’s name, model name, date of manufacture, serial number, and MES ID.

+How trouble arose. Go into details as much as possible.

+Name of the office, organization etc of the vessel, the contact place and the telephone/fax number.

Recommendation of professional maintenance

The performance of the set may degrade due to the aging of parts and so on, although the rate depends on how the equipment is used.

Maintenance by professional service engineer other than daily check by ship’s crew is recommended.

For this professional maintenance, please contact the purchasing dealer. This is a charged service.

10. After-sales Service

Disposal of the JUE-501/JUE-251

Follow the rule of the pertinent local government when you abandon the JUE-501/JUE-251 (ADE).

For details, contact the dealer, our service office (Refer to the list of offices at the end of the volume) or a concerned local government.

11. Specification

JUE-501 (ADE, BDE)

1. Inmarsat FleetBroadband MES type		Class 8	
2. Frequency	Transmission	1626.5 to 1660.5 MHz, 1668.0 to 1675.0 MHz	
	Reception	1518.0 to 1559.0 MHz	
3. Maximum E.I.R.P		+22.0dBW + 1/-2dB	
4. G/T (Reception capacity)		-7.0dBK	
5. Antenna	Type	54cm Φ flat	
	Polarization	Right-Hand Circular Polarization (RHCP)	
	Beam width	22degrees, in 3dB down direction	
	Radome	Glass Fiber Reinforced Plastics (GFRP)	
6. Modulation	O-QPSK	For voice	
	$\pi/4$ -QPSK		
	16QAM		
7. Primary power	Voltage	Connecting with EXT PSU:100/110 or 89VAC to 266VAC +21.6VDC to +31.2VDC	
	Current Maximum	2 A or less in reception 6.5A or less in transmission with connecting option	
8. Dimension	ADE	Φ 630mm \times h683mm	
	BDE	h65mm \times w262mm \times d275mm	
9. Mass	ADE	20kg	
	BDE	4.5kg	
10. Environmental conditions			
1) Temperature	ADE	-25°C to +55°C	
	BDE	-25°C to +55°C (Handset -15°C to +55°C)	
2) Relative humidity		Up to +40°C, 95%	
3) Oscillation		Compliance with IEC60945 4th edition	
4) Ship's motion	Motion	Amplitude	Period
	Roll	+30°	8 s
	Pitch	+10°	6 s
	Yaw	+8°	50 s
	Surge	+0.2g	
	Sway	+0.2g	
	Heave	+0.5g	
	Turning Rate	+6° /s	1deg/s ²
Headway	30knots		

11. Specification

5) Solar Radiation (ADE)	Infrared Radiation 500 watts / m ²
	Ultraviolet Radiation 54watts / m ²
6) Icing (ADE)	Up to 25mm
7) Precipitation (ADE)	Up to 100mm / hour
8) Wind (ADE)	Up to 100knots in operation

JUE-251 (ADE, BDE)

1. Inmarsat FleetBroadband MES type		Class 9	
2. Frequency	Transmission	1626.5 to 1660.5 MHz, 1668.0 to 1675.0MHz	
	Reception	1518.0 to 1559.0 MHz	
3. Maximum E.I.R.P		+15.1dBW + 1/-2dB	
4. G/T (Reception capacity)		-15.5dBK	
5. Antenna	Type	25cm Φ flat	
	Polarization	Right-Hand Circular Polarization (RHCP)	
	Beam width	40degrees, in 3dB down direction	
	Radome	Acrylonitrile Butadiene Styrene (AES)	
6. Modulation	O-QPSK	For voice	
	$\pi/4$ -QPSK		
	16QAM		
7. Primary power	Voltage	Connecting with EXT PSU:100/110 or 89VAC to 266VAC +21.6VDC to +31.2VDC	
	Current Maximum	2 A or less in reception 6.5A or less in transmission with connecting option	
8. Dimension	ADE	Φ 285mm \times h364mm	
	BDE	h65mm \times w262mm \times d275mm	
9. Mass	ADE	4.7kg	
	BDE	4.5kg	
10. Environmental conditions			
1) Temperature	ADE	-25°C to +55°C	
	BDE	-25°C to +55°C (Handset -15°C to +55°C)	
2) Relative humidity		Up to +40°C, 95%	
3) Oscillation		Compliance with IEC60945 4th edition	
4) Ship's motion	Motion	Amplitude	Period
	Roll	+30°	8 s
	Pitch	+10°	6 s
	Yaw	+8°	50 s

	Surge	+0.2g	
	Sway	+0.2g	
	Heave	+0.5g	
	Turning Rate	+6° /s	1deg/s ²
	Headway	30knots	
5) Solar Radiation (ADE)	Infrared Radiation	500 watts / m ²	
	Ultraviolet Radiation	54watts / m ²	
6) Icing (ADE)	Up to 25mm		
7) Precipitation (ADE)	Up to 100mm / hour		
8) Wind (ADE)	Up to 100knots in operation		

11. Specification

[Intentionally Blank]

Appendix A Handset menu tree

A.1 JUE-501/JUE-251 Handset menus for all users (1)

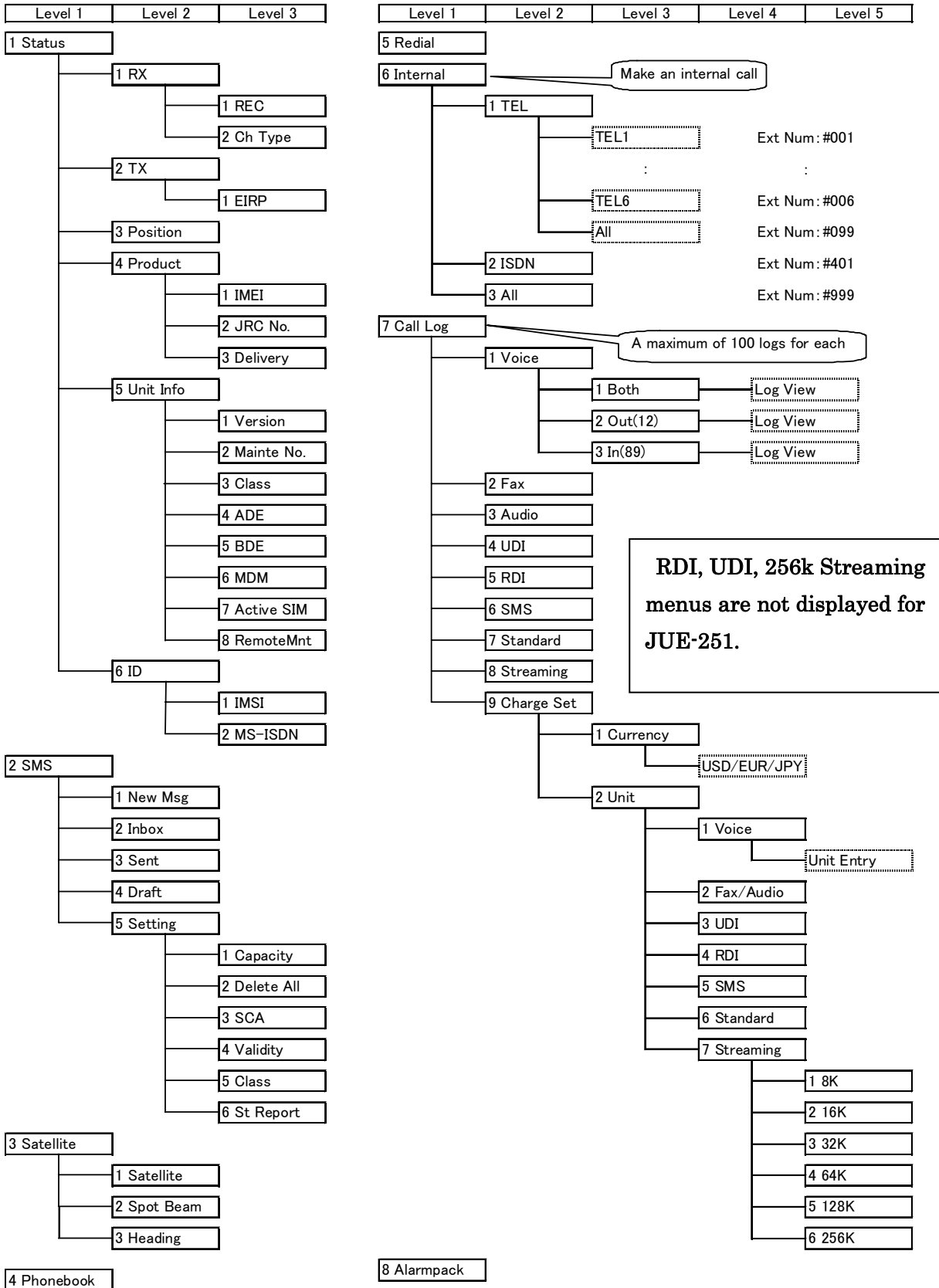

Fig.A.1 Handset menus for all users (1) menu tree

A.2 JUE-501/JUE-251 Handset menus for all users (2) SMS menu detail

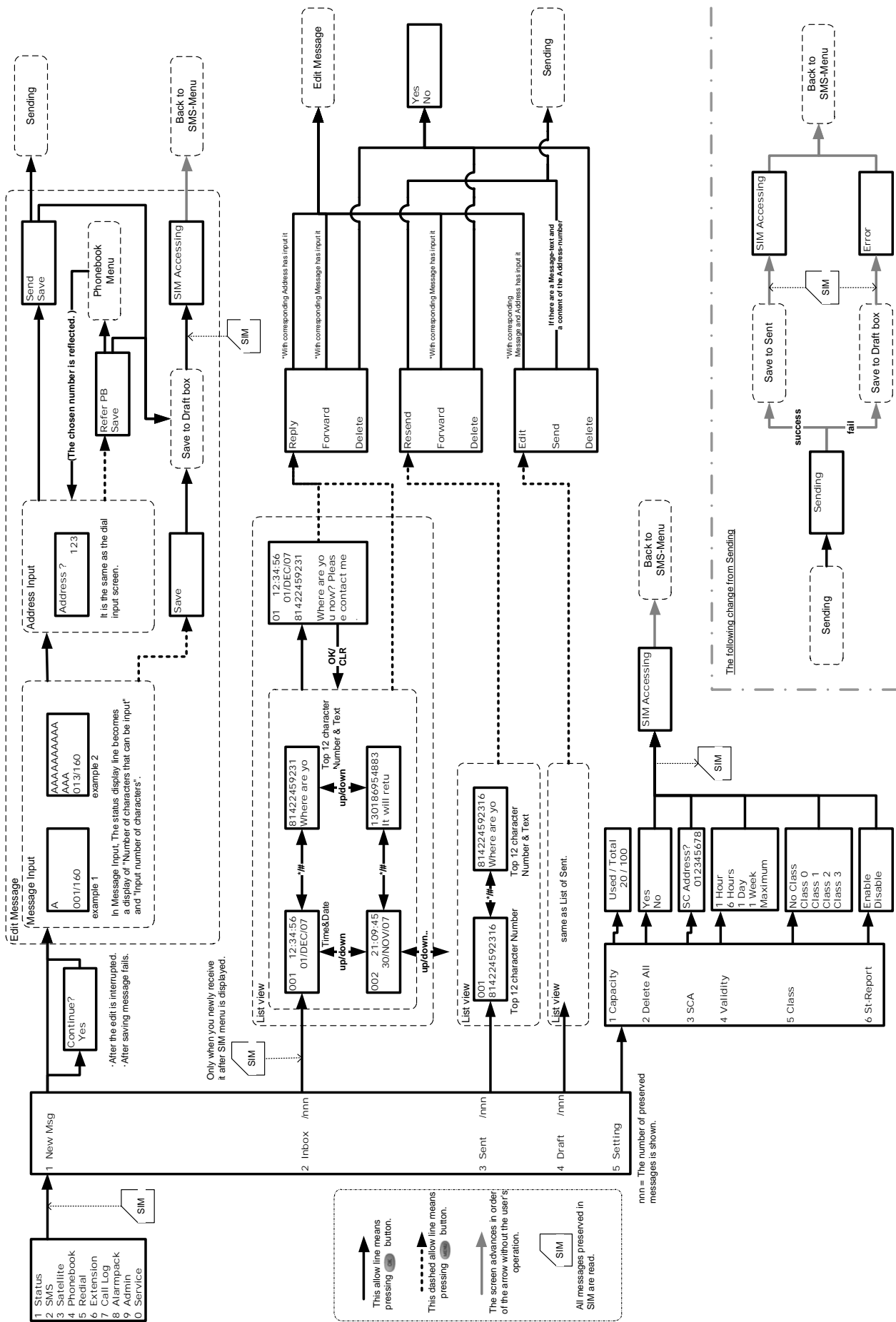

Fig. A.2 Handset menus for all users (2) SMS menu detail

A.3 JUE-501/JUE-251 Handset menus for Admin users

Fig. A.3.1

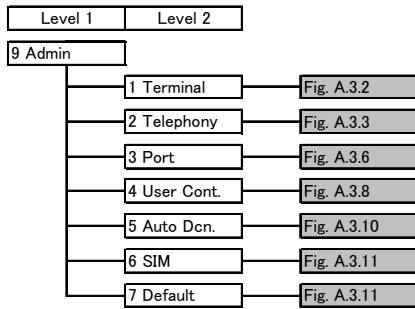

Fig. A.3.2

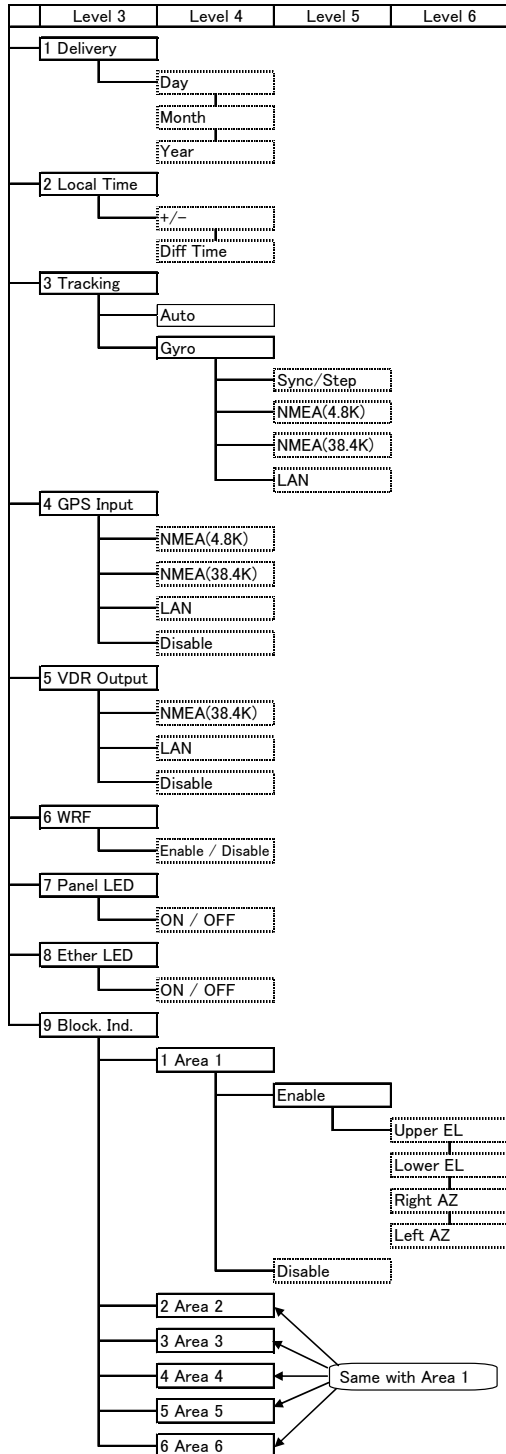
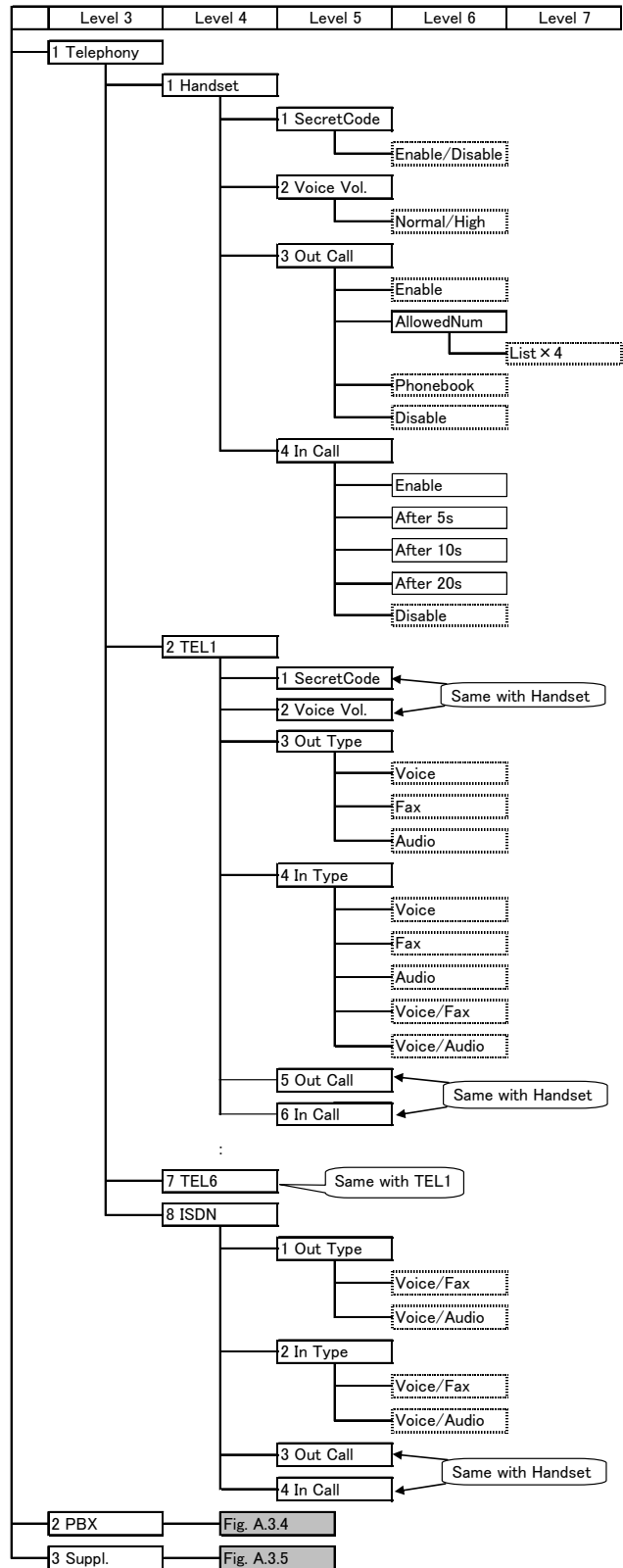

Fig. A.3.3



RDI, UDI, 256k Streaming menus are not displayed for JUE-251.

Appendix A Handset menu tree

Fig. A.3.4

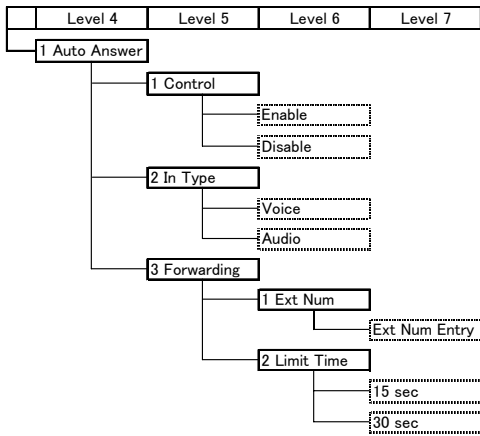

Fig. A.3.5

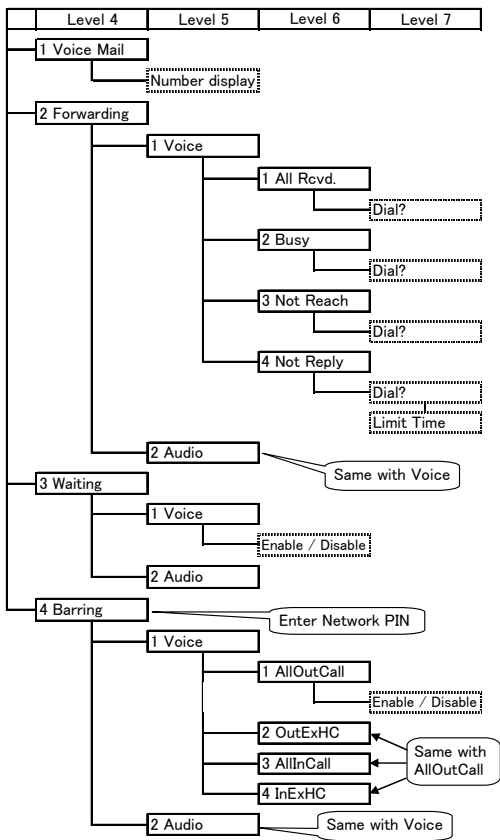

Fig. A.3.8

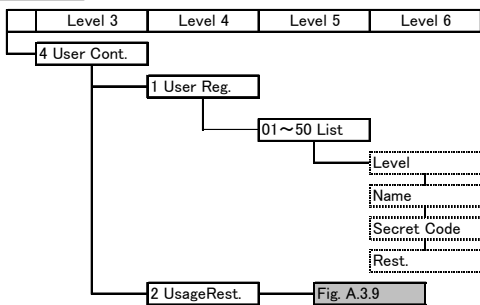
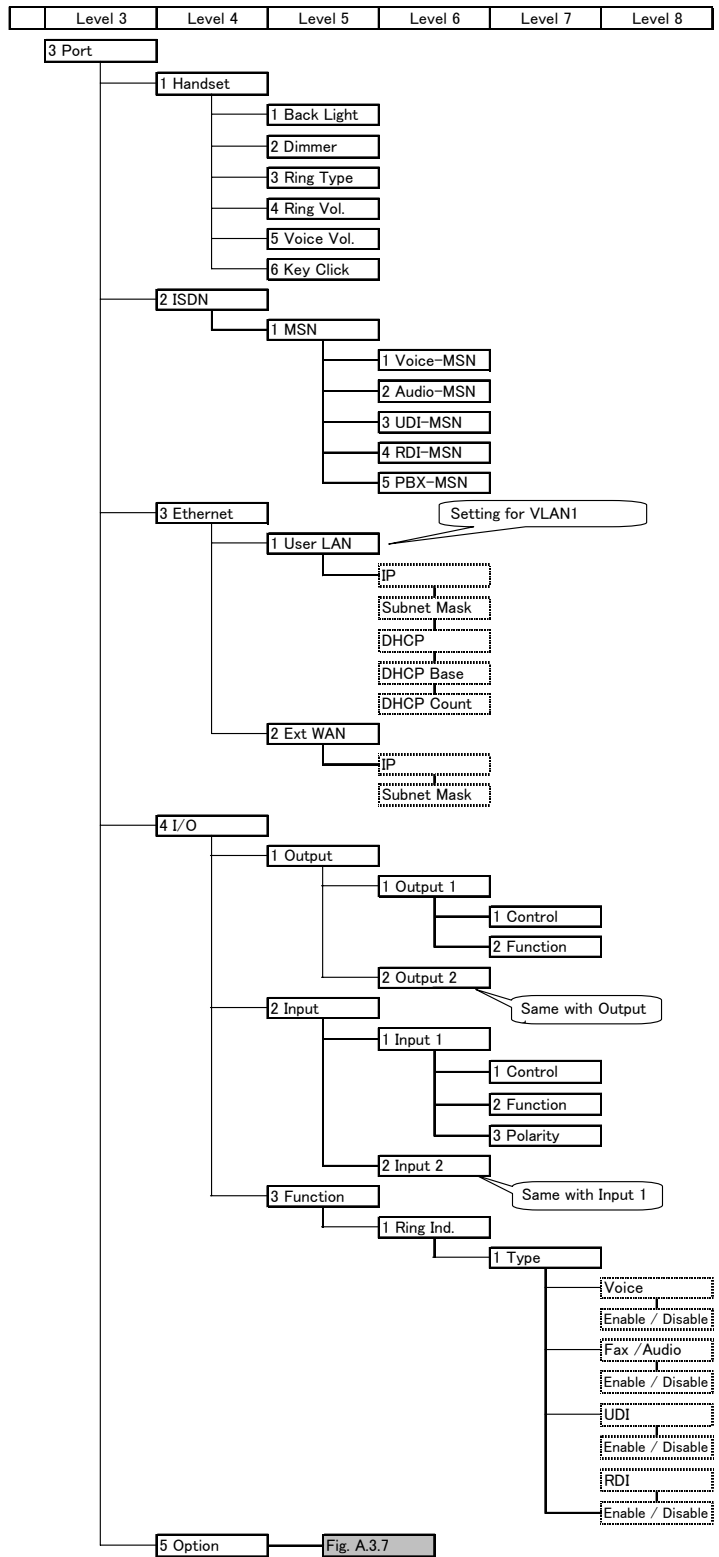
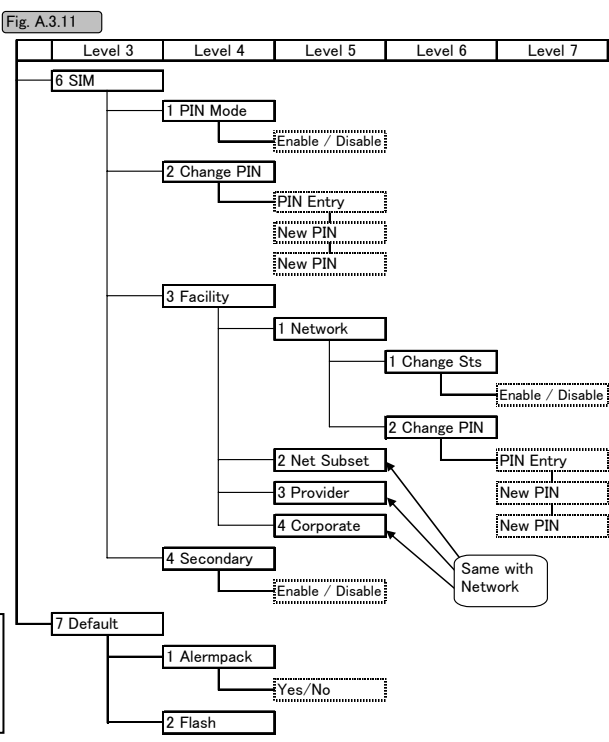
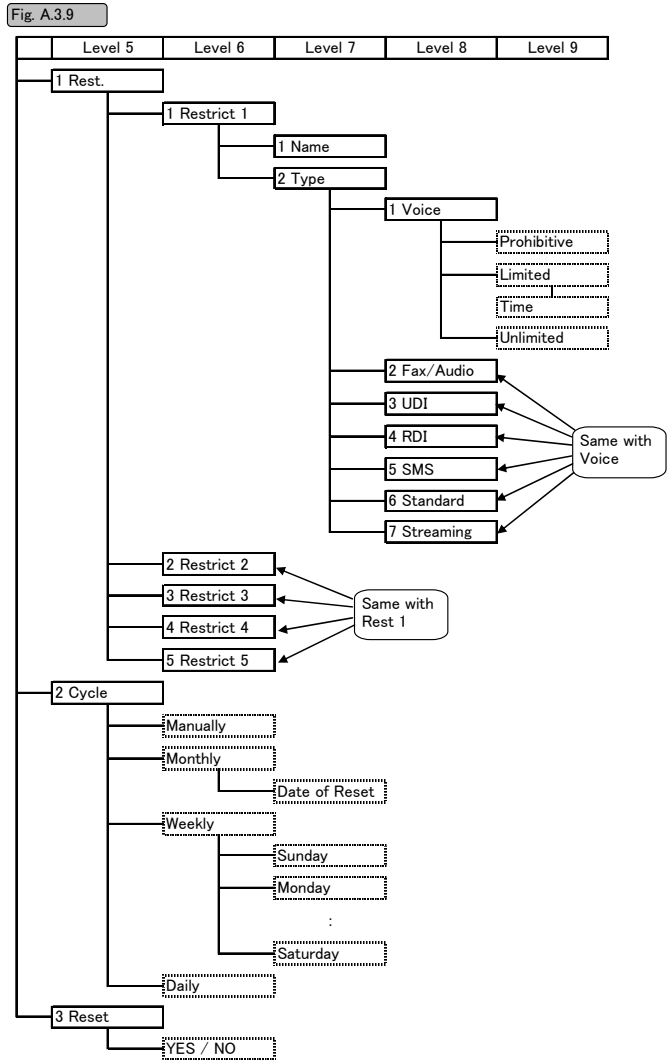
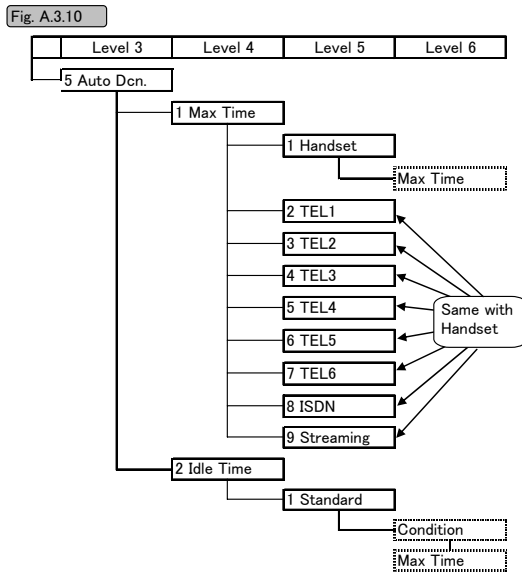
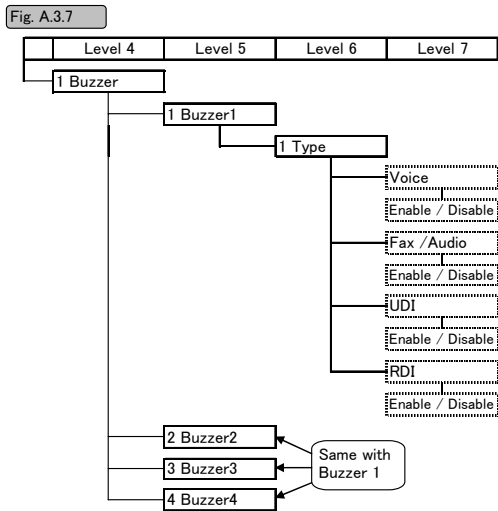

Fig. A.3.6



RDI, UDI, 256k Streaming menus are not displayed for JUE-251.



RDI, UDI, 256k Streaming menus are not displayed for JUE-251.

Fig. A.3 Handset menus for Admin users

This page is remained as a blank.

Appendix B Web menu tree

B.1 For JUE-501/JUE-251 all user

*****Guest Menu*****

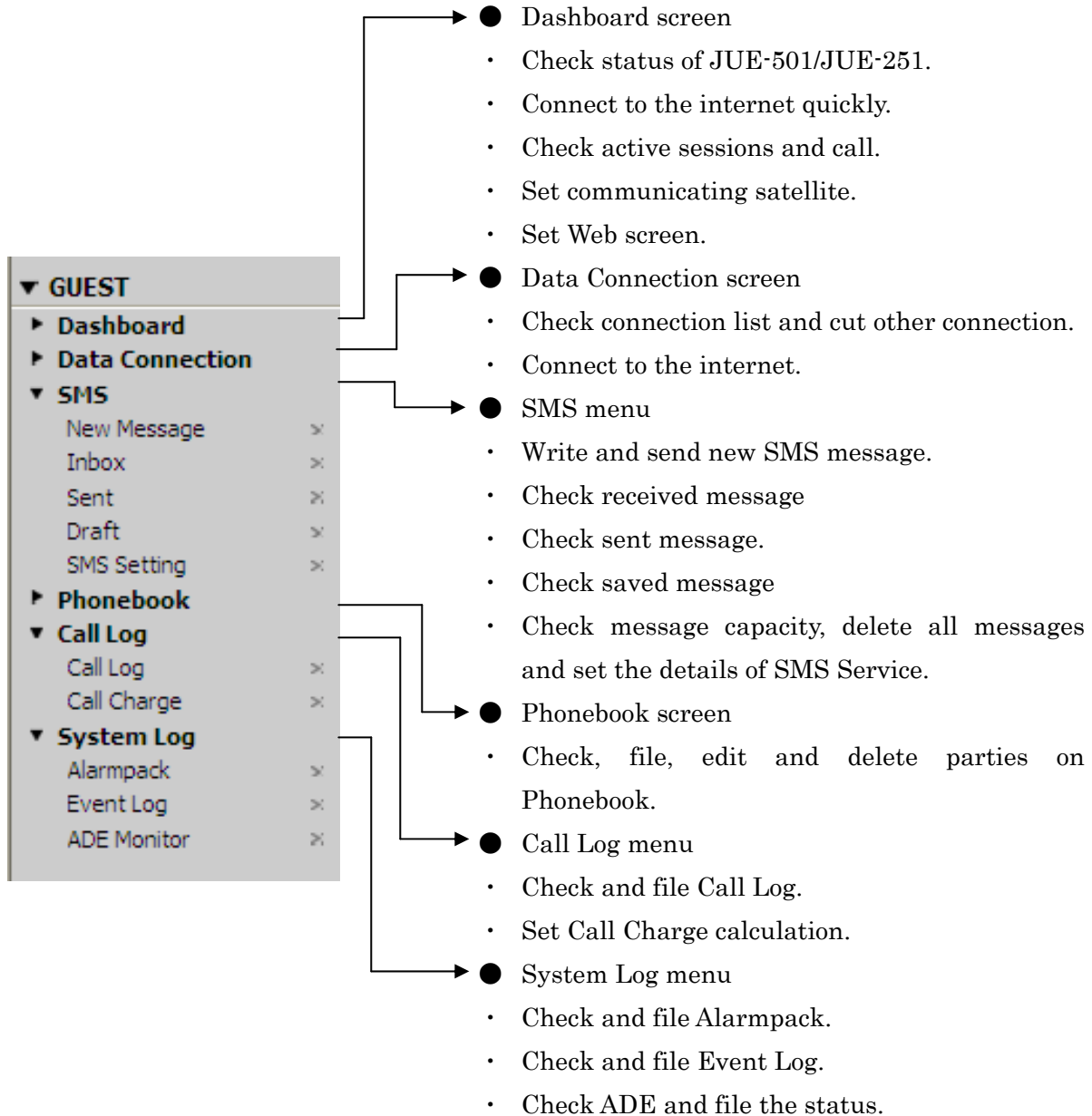

B.2 For JUE-501/JUE-251 Admin user

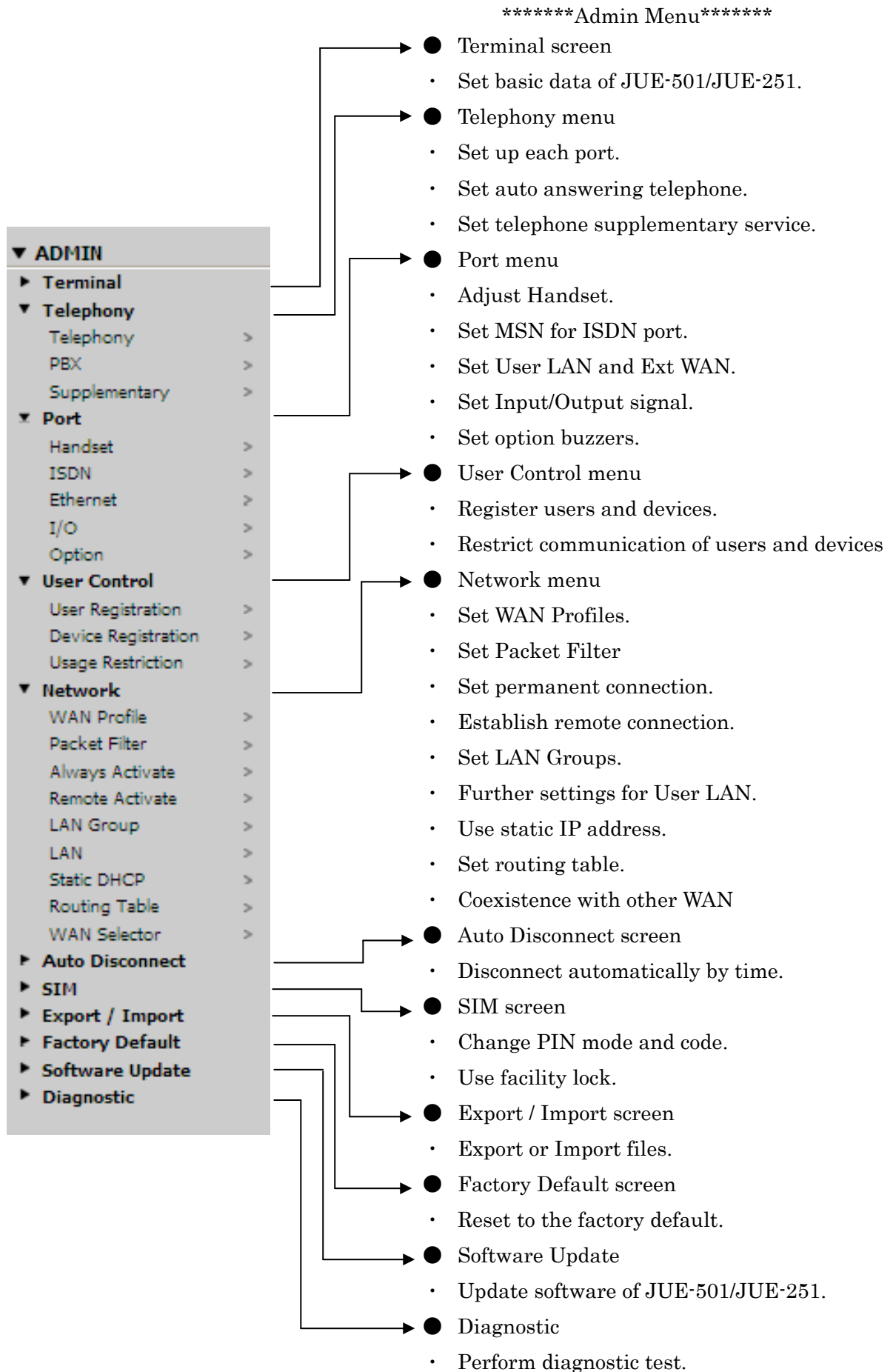

Appendix C Junction Board

C.1 Junction Board appearance



Fig. C.1 Junction Board

C.2 Dimensional drawing of JB

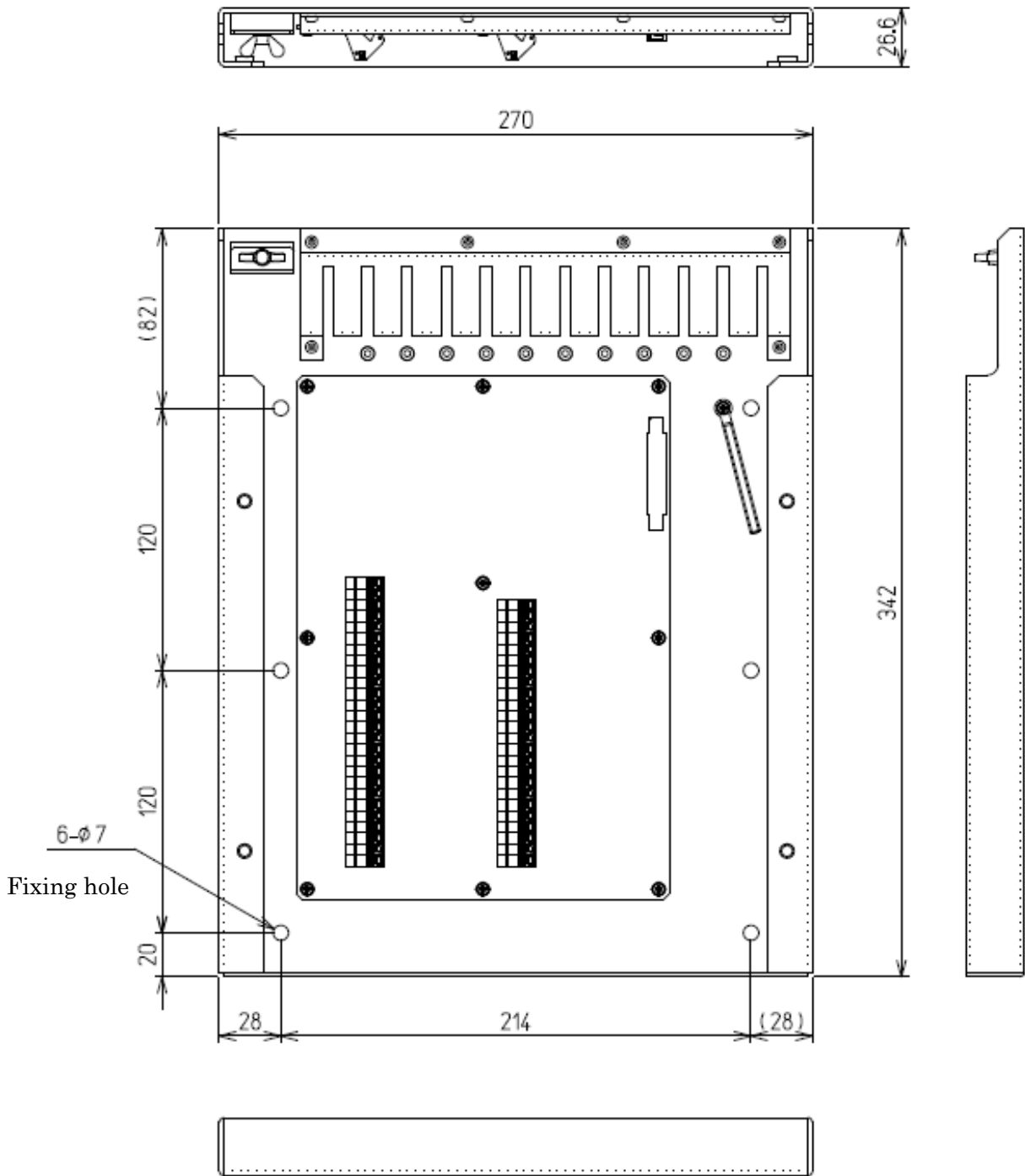

Unit: mm
Mass. approx. 2.0 kg

Fig. C.2 Dimensional drawing of JB

C.3 Screen display of Handset , when JB /GYRO are used (Corresponded to Chapter 4.1.4)

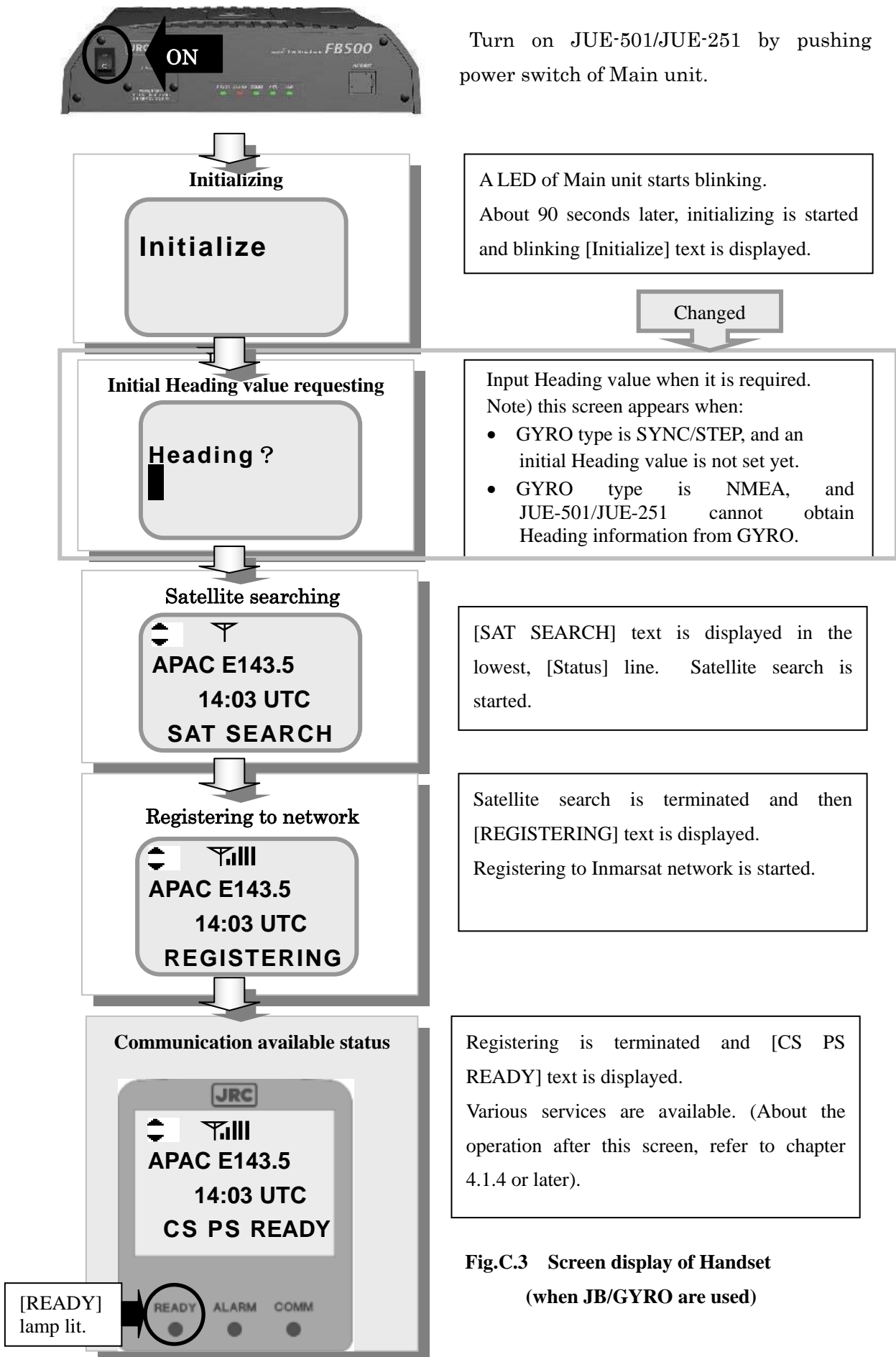

Fig.C.3 Screen display of Handset (when JB/GYRO are used)

C.4 Unit Info menu , when JB/GYRO are used (Corresponded to Chapter 7.1.5)

In this menu, user can display the software version, maintenance No. and status of ADE/BDE.

By set to GYRO tracking, [4 BDE] screen is changed.

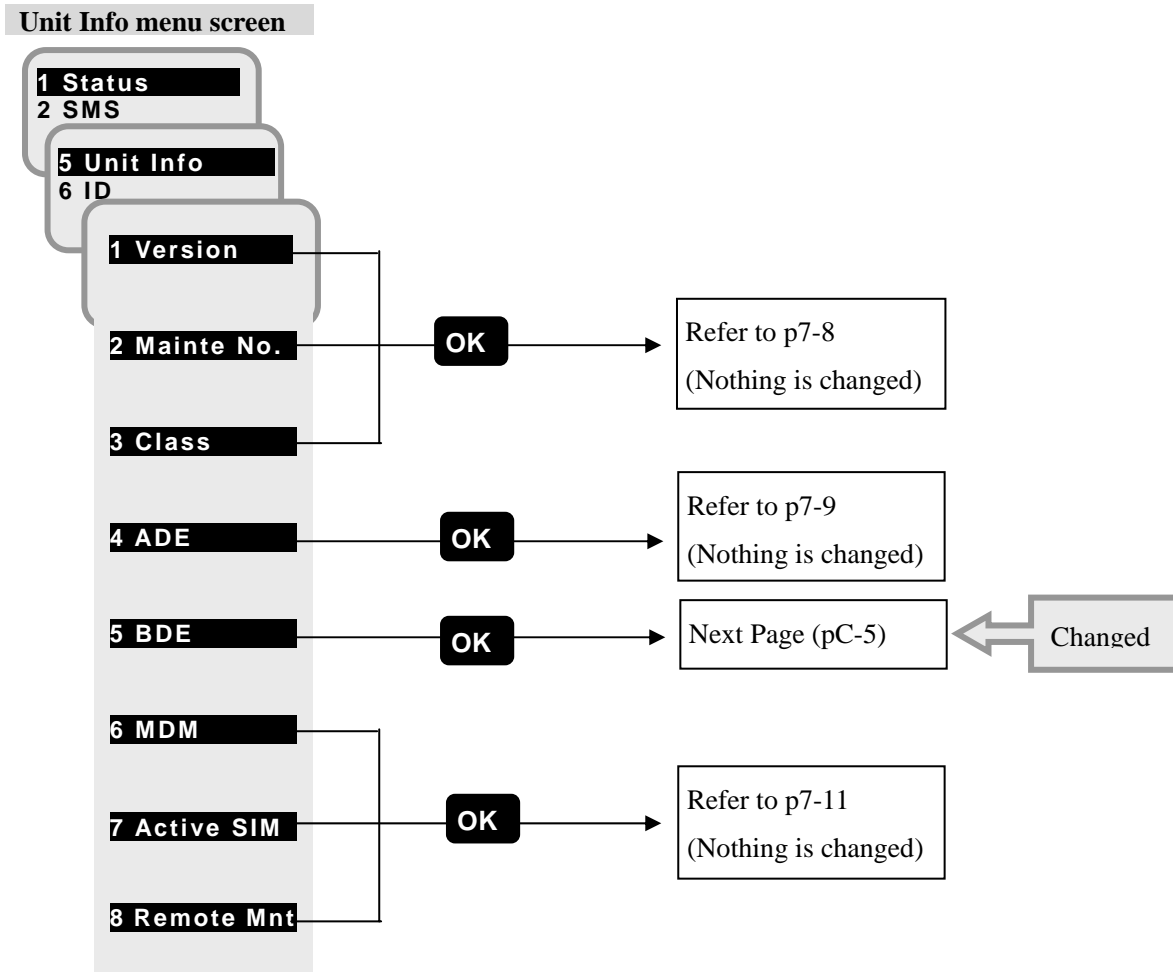
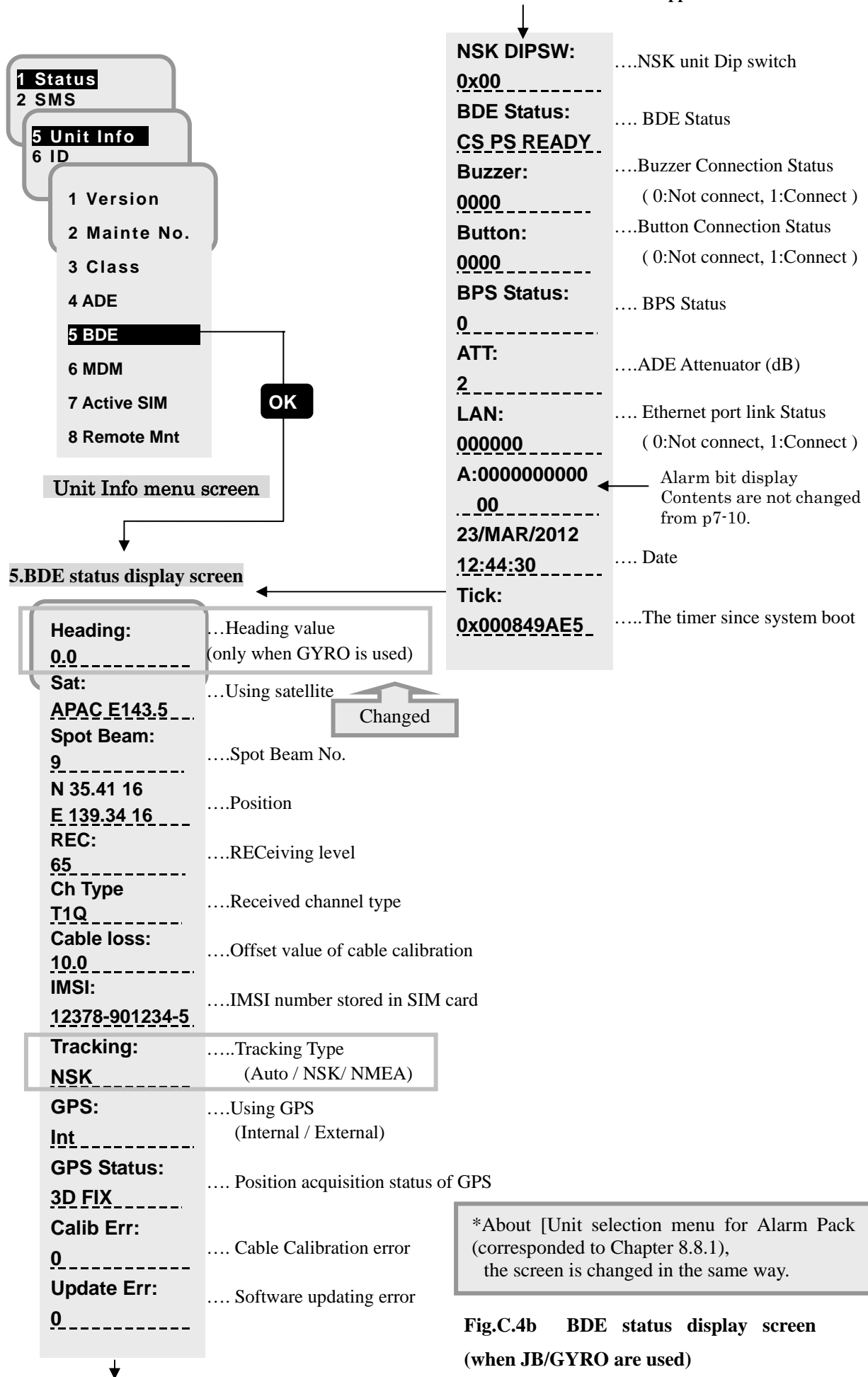

Fig.C.4a Unit Info menu



*About [Unit selection menu for Alarm Pack (corresponded to Chapter 8.8.1), the screen is changed in the same way.

Fig.C.4b BDE status display screen (when JB/GYRO are used)

C.5 Satellite menu, when JB/GYRO are used (Corresponded to 7.1.3) (MENU+ 3)

Editing the Heading value is required after changed to GYRO tracking system.

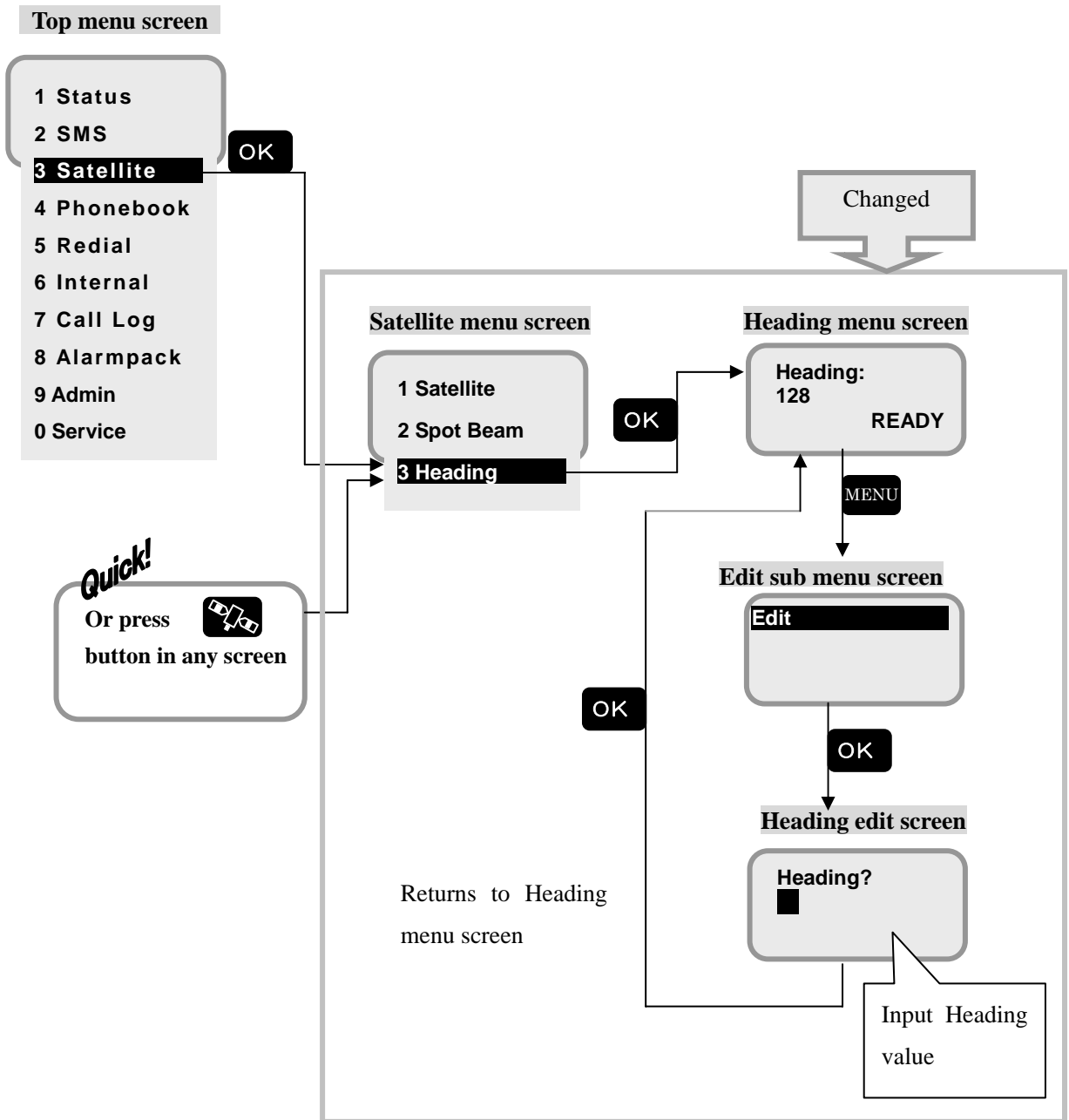

Fig.C.5 Heading menu screen of Satellite menu (when JB/GYRO are used)

Appendix D Software updating procedure**NOTE**

We recommend you to backup your settings before updating software though it doesn't reset your settings.

Update JUE-501/JUE-251 software with following procedure a) to d).

* Do not connect any router or other equipments. Connect your PC directly to JUE-501/JUE-251.

a) Download the latest software for JUE-501/JUE-251

Confirm the website to check whether the latest software is uploaded or not, from the PC connected to Internet. Download if the latest software is uploaded. (For details, refer to "D.1. Downloading the latest software")

b) Open Software Update screen

Connect your PC directly to JUE-501/JUE-251 with Ethernet cable and launch JUE-501/JUE-251 Web menu system. Refer to [Sec. 6.1 Connect your PC to JUE-501/JUE-251] for details.

Open Software Update screen on your Web browser by selecting [Software Update] from menu panel.

c) Update the software of JUE-501/JUE-251

Select the file downloaded for software updating in step a) and click "Update" button. It may take more than 3 minutes to update software. Do not operate Web browser while you are updating software. (For details, refer to "D.2. Update software")

d) Confirm the updated software version

Confirm the software version after updating, to check that JUE-501/JUE-251 software is correctly updated or not. (For details, refer to "D.3. Confirm the update software version")

D.1. Downloading the latest software

The latest software of JUE-501/JUE-251 is uploaded on the HP of Inmarsat.

The URL is as follows:

<http://www.inmarsat.com/Support/FleetBroadband/Firmware.aspx>

FleetBroadband Firmware

The latest firmware for your FleetBroadband terminal. Where available, the downloads include application notes and installation guidance.

Manufacturer	Terminal(s)	Version	OS	Size	Download via		
			PC Mac		Americas	Europe	Asia-Pacific
JRC							
	JUE-250 *	01.16	X	5.14MB	zip	zip	zip
	JUE-500 **	11.27	X	7.61MB	zip	zip	zip
Thrane & Thrane							
	Sailor 250 and Sailor 500	1.10	X X	5.34MB	zip	zip	zip

* Please ensure when upgrading to version 01.16 that version 01.04 is previously installed
 ** Please ensure when upgrading to version 11.27 that version 11.03 is previously installed

If the software’s version on the HP is larger than your JUE-501/JUE-251’s software version, download the software from HP.

Software version of JUE-501/JUE-251 can be displayed on the Handset screen with following operation:

<1> Status - <5> Unit Info - <2> Mainte No.- BDE-App

D.2. Update software

Note

- Do not turn OFF the power supply of JUE-501/JUE-251 and/or PC during the software forwarding or updating
- Application-software forwarding or updating takes up to 3 minutes.
- Main-software updating can not be performed in main mode.

1. Click [Software Update] on the left [menu] panel.
 - [Software Update] screen will be displayed.

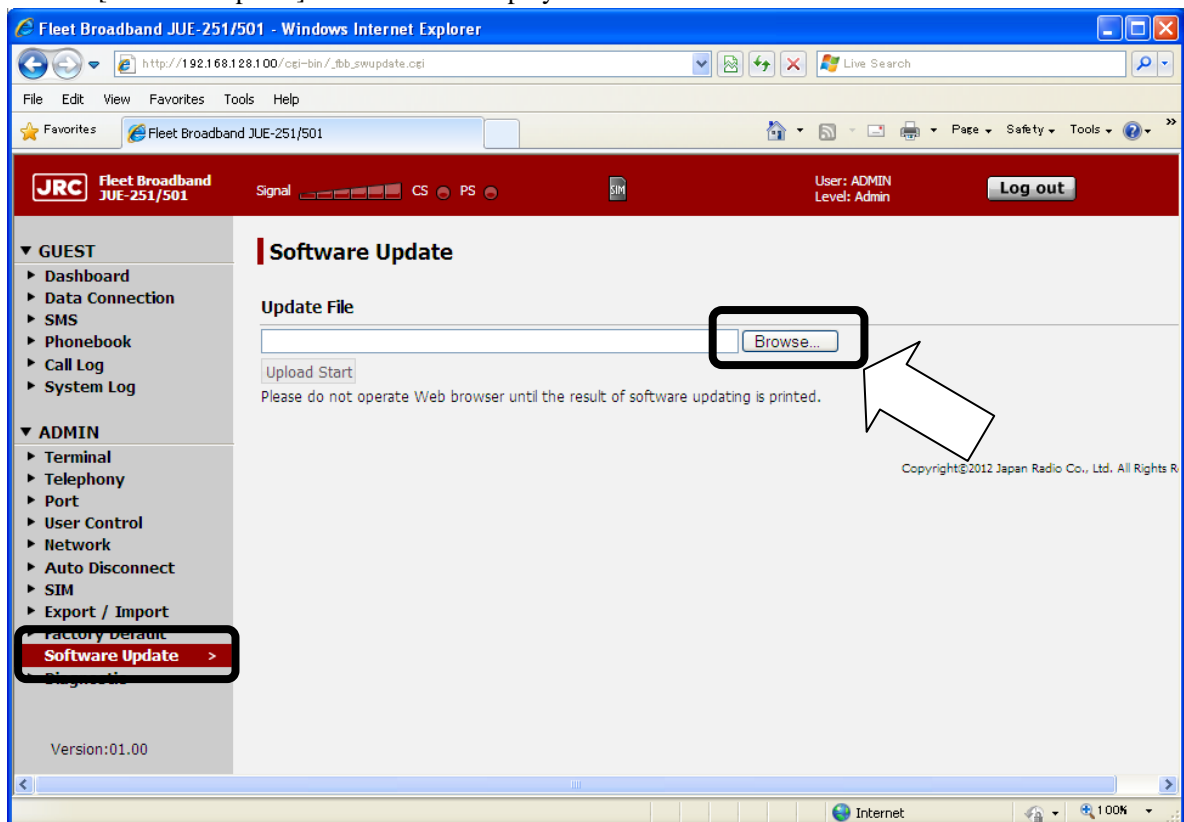

2. Click [Browse] button. Then file selection dialog will appear.

Appendix D Software updating procedure

3. Select the file you have downloaded at the step a) or [D.1 Download the latest software] and click [Open].

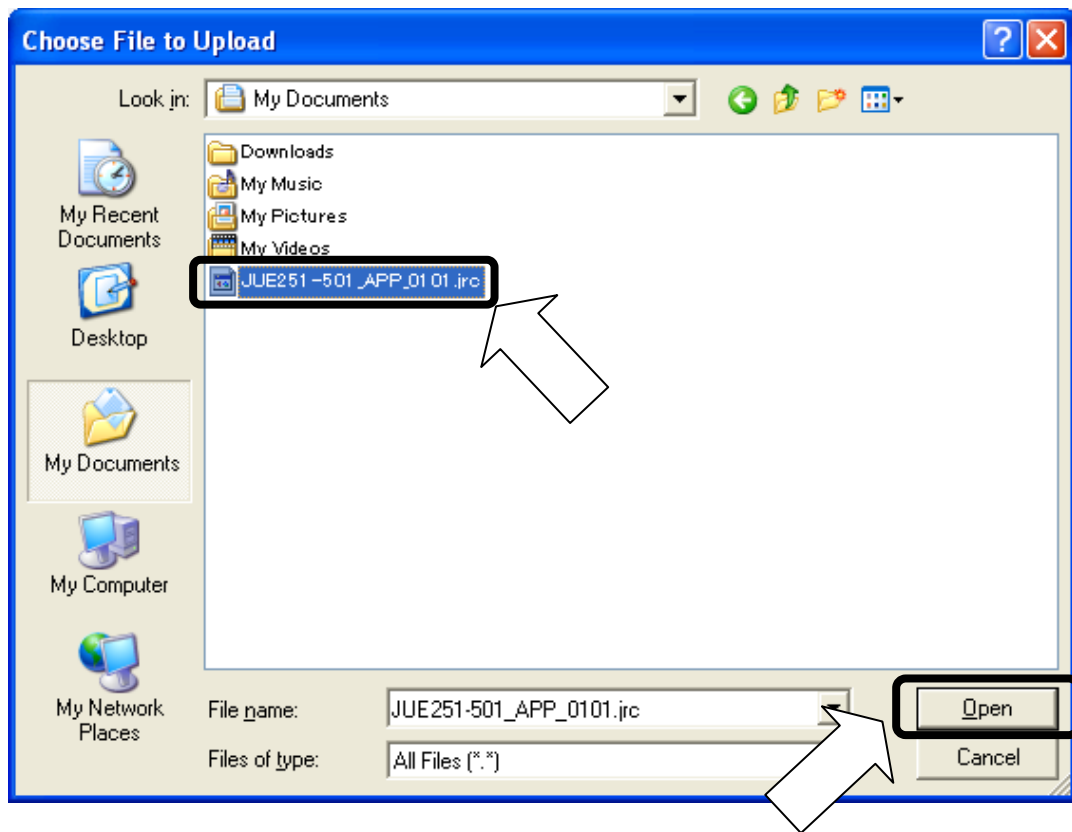

4. Click [Upload Start] button.
 - The [Upload Start] button changes into disable (gray).
 - Wait until the update was completed and the result is printed.

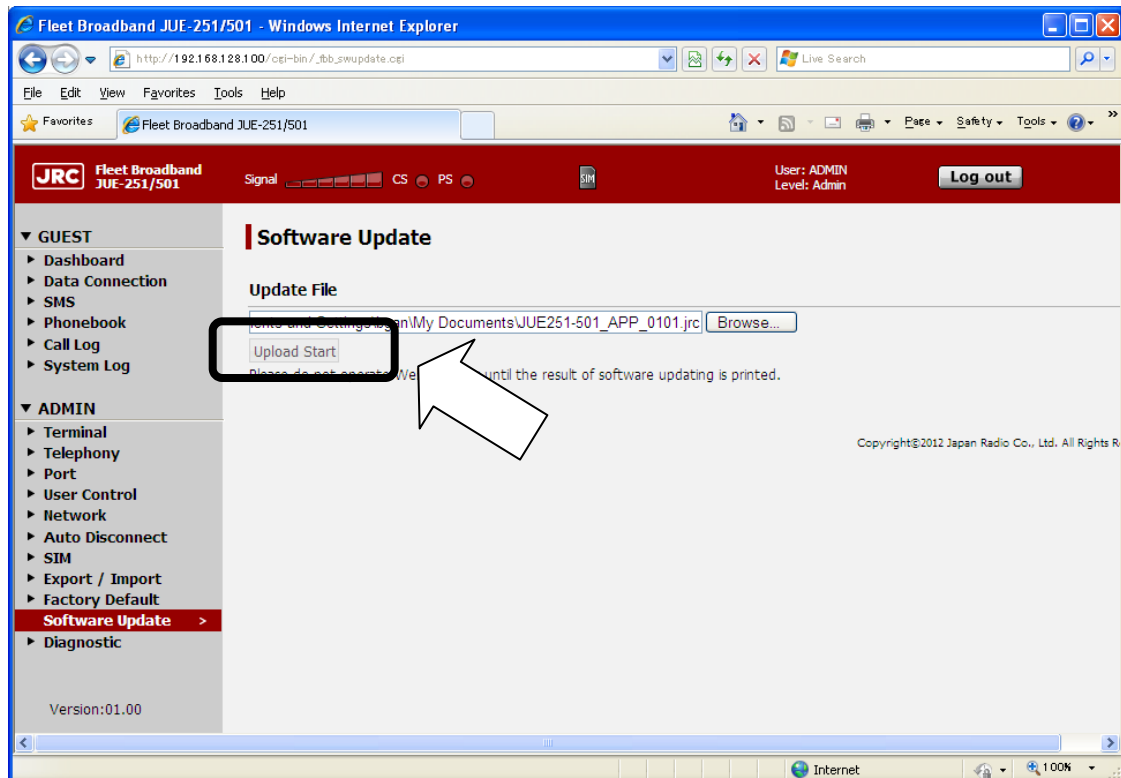

5. Check the result.

NOTE

- Please do not operate your Web browser until the result is printed on the screen.
- It may take more than 3 minutes.
- In the case of unresponsiveness in 5 minutes, please reload the Web page and retry software updating with following the software updating procedure (on page D-1 of this manual) from a) to d).

- [Success] is displayed when the update finished successfully. Then, reboot your system.
- [Error] is displayed when the update has failed. Go to the next page.

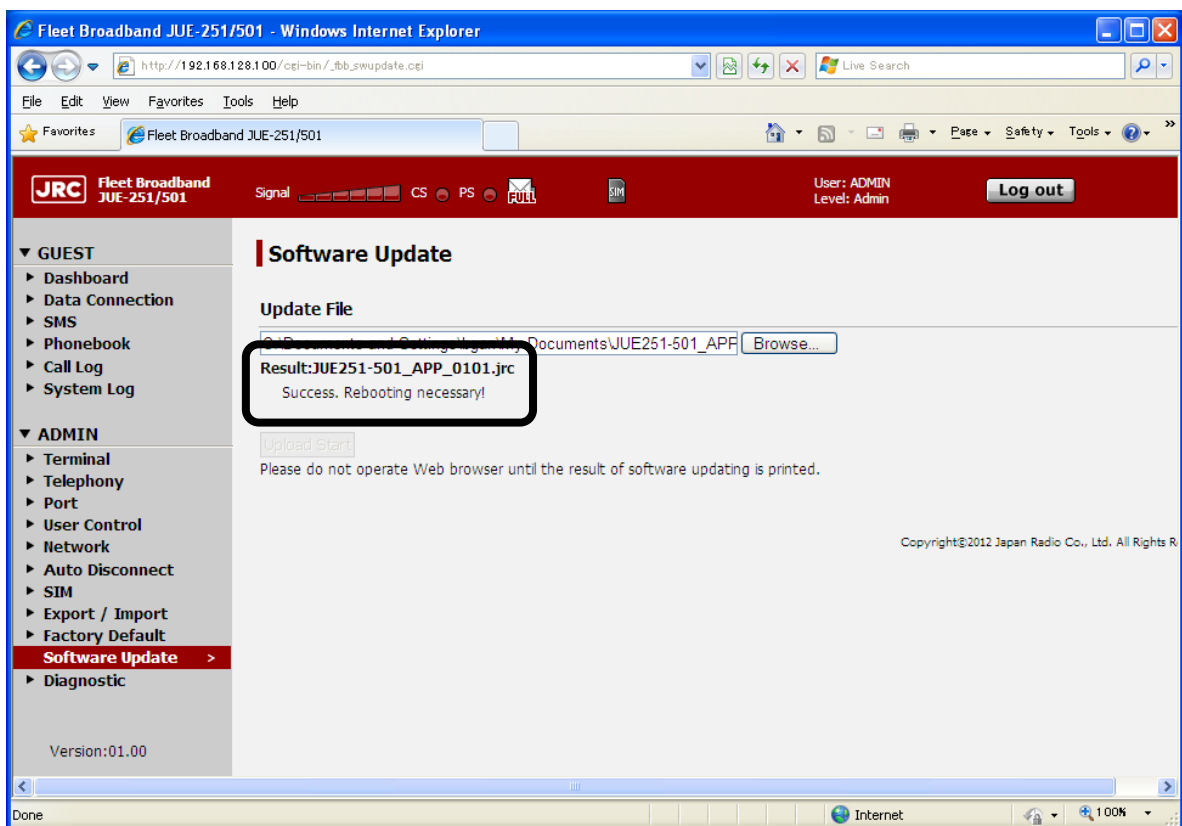

When software update is failed

Update is failed when “Update Error” is printed on your Web browser.

Check the error code below. Reboot your JUE-501/JUE-251 and retry updating with following the software updating procedure (on page D-1 of this manual) from a) to d).

If software updating fails continuously or the system would not boot, try to software update in safe mode. (Refer to “D.4. Software Updating Procedure in Safe Mode” for details.)

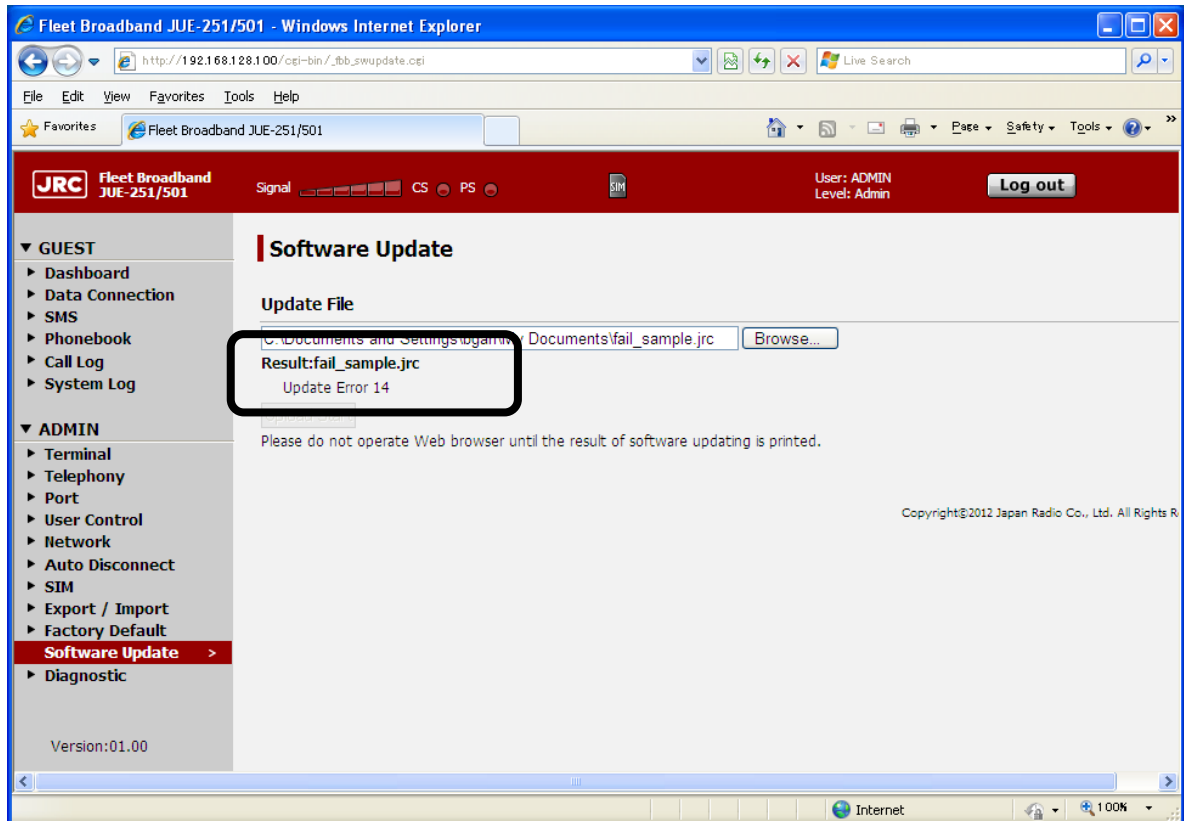

Table D.2 Software updating error code

Code	Supposed cause
1	The system is under the software updating already.
2~13 and 17	Internal error.
14~16	The file you uploaded is wrong file.
21~31	It failed in uploading the file.

D.3. Confirm the updated software version

Check that the software version is correctly updated or not, from the following the Handset menu,
 <1> Status - <5> Unit Info - <2> Mainte No. – BDE-App

When the update is succeeded, BDE-App No. is changed to the same number as the [xxxx] of the software file [JUE251-501_App_xxxx.jrc]

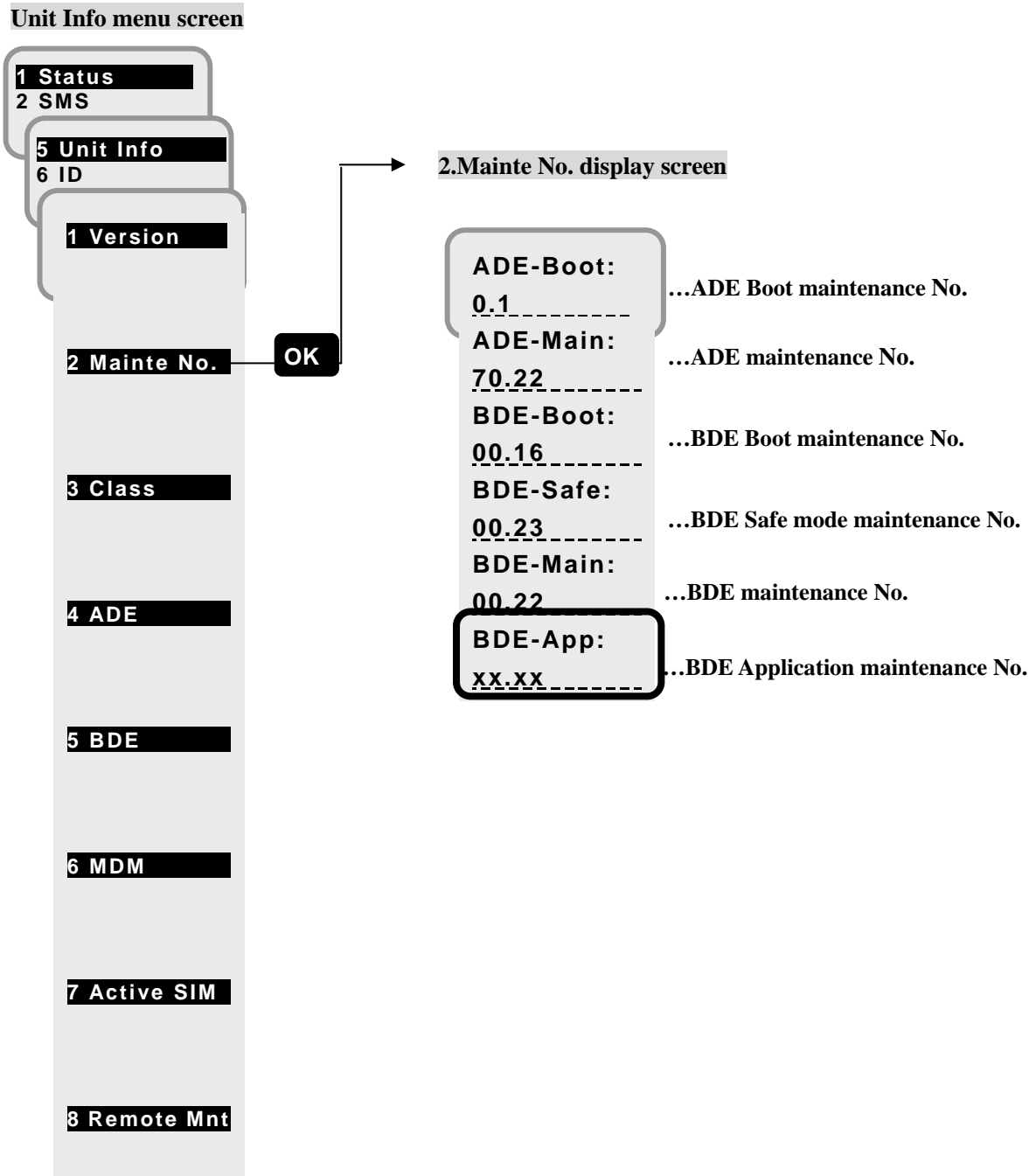

D.4. Software Updating Procedure in Safe Mode

If the system would not boot or software updating fails continuously, try to software update in safe mode with following procedure A) to E).

* Do not connect any router or other equipments. Connect your PC directly to JUE-501/JUE-251.

The IP address of the main unit is set to “192.168.128.100” in Safe Mode even when you have changed it in Main Mode.

NOTE

We recommend you to backup your settings before updating software though software update doesn't reset your settings.

A) Download the latest software for JUE-501/JUE-251

Confirm the website to check whether the latest software is uploaded or not, from the PC connected to Internet. Download if the latest software is uploaded. (For details, refer to “D.1. Downloading the latest software”)

B) Start JUE-501/JUE-251 in Safe Mode

Safe mode is available by turning on the power supply with the FN (function) button (right side button of the Handset) pressed. (For details, refer to “D.4.1. Start in Safe Mode”.)

C) Confirm the connection

JUE-501/JUE-251 software updating is executed by Web browser on your PC.

Prepare a PC and connect it to your JUE-501/JUE-251.

* Windows XP/Vista/7 32bit OS is required.

The IP address of the main unit is set to “192.168.128.100” in Safe Mode even when you have changed it in Main Mode. To connect your PC with JUE-501/JUE-251, refer to [Sec. 6.1 Connect your PC to JUE-501/JUE-251].

D) Update software

Launch your Web browser* and enter “192.168.128.100” to the URL box. The Safe Mode screen will appear. Click [Software Update] on the left [menu] panel. Then, Update the software by the downloaded software. (For details, refer to “D.4.3 Update software in safe mode”)

* While JUE-501/JUE-251 officially supports Microsoft Internet Explorer7 and Mozilla Firefox3.6, their upper version can be available when they have compatible system.

E) Confirm the updated software version

Confirm the software version after updating, to check that JUE-501/JUE-251 software is correctly updated or not. (For details, refer to “D.3. Confirm the update software version”)

D.4.1 Start in Safe Mode

In this subsection, the way of starting JUE-501/JUE-251 in safe mode is described. Software updating and factory resetting is available in safe mode.

1. Turn OFF the power supply of JUE-501/JUE-251.



2. Turn ON the power supply of JUE-501/JUE-251 with pressing the FN (function) button (right side button of the Handset).

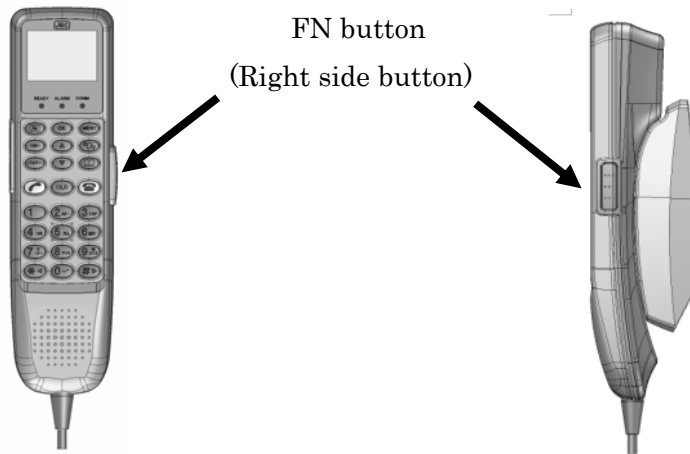

3. Leave your finger from FN button when Ready LED lamp of BDE lit in red.



* Nothing is displayed on Handset when the system has been booted in safe mode.

D.4.2 Set your PC

The IP address of the main unit is set to “192.168.128.100” in Safe Mode even when you have changed it in Main Mode. Do not connect any router or other equipments. Connect your PC directly to JUE-501/JUE-251.

For more information about connecting your PC with JUE-501/JUE-251, refer to [Sec.6.1 Connect Your PC to JUE-501/JUE-251 (p6-2)].

D.4.3 Update software in safe mode

Note

- Do not turn OFF the power supply of JUE-501/JUE-251 and/or PC during the software forwarding or updating
- Application-software forwarding or updating takes up to 3 minutes.
- Main-software forwarding or updating takes up to 10 minutes.

1. Launch your Web browser* and enter the URL box “192.168.128.100”.

- * While JUE-501/JUE-251 officially supports Microsoft Internet Explorer7 and Mozilla Firefox3.6, their upper version can be available when they have compatible system.
- The Safe Mode screen will appear.

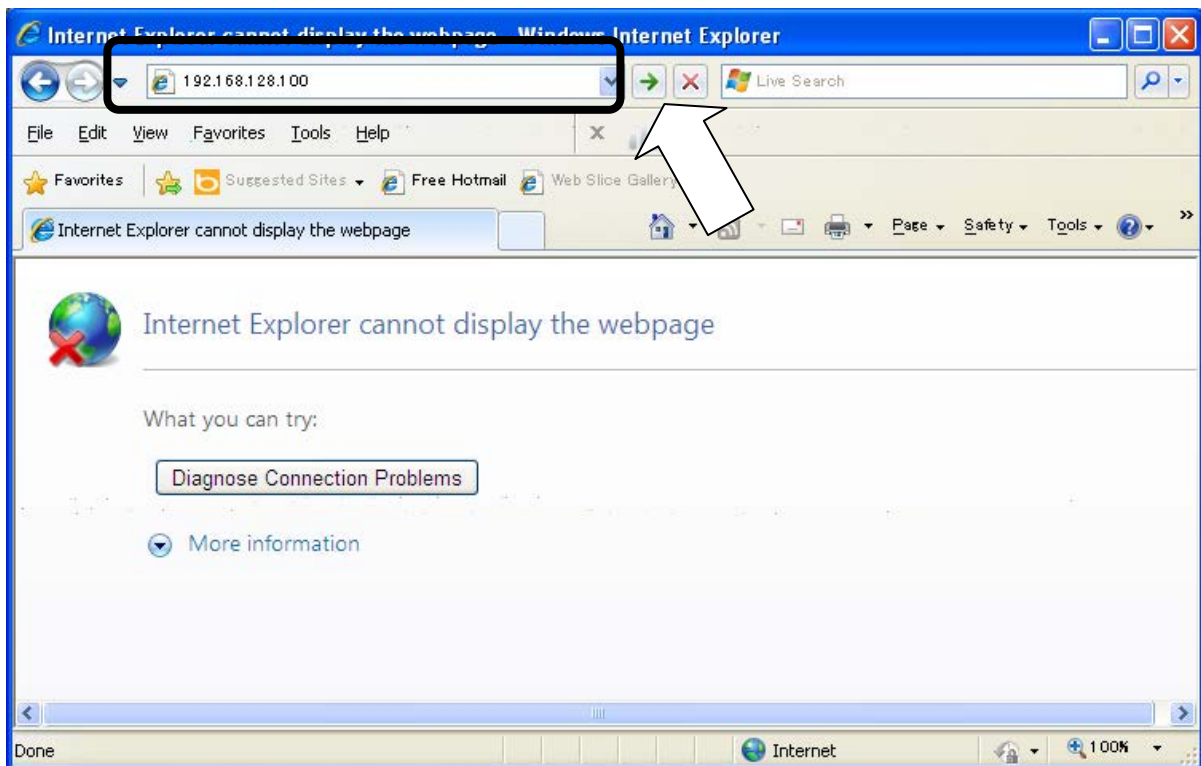

If you can not access the main unit, please check the IP address of your PC.

2. Click [Software Update] on the left [menu] panel.
- [Software Update] screen will be displayed.

Appendix D Software updating procedure

3. Click [Browse] button. Then file selection dialog will appear.

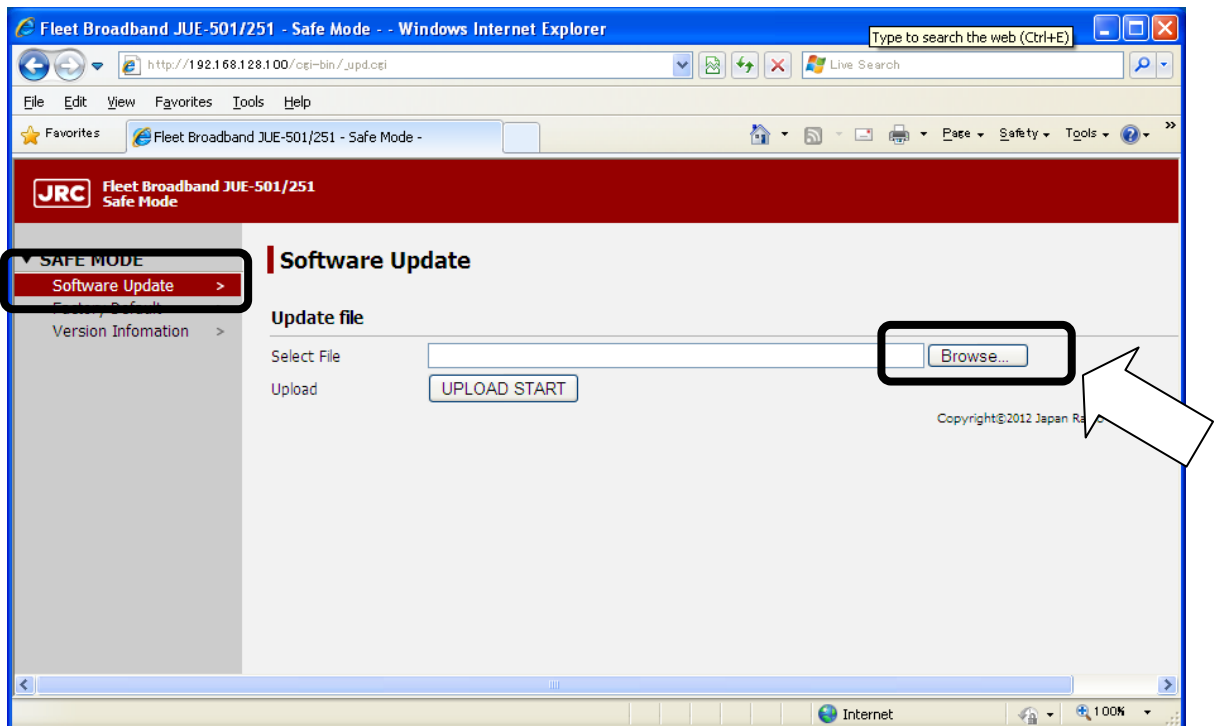

4. Select the file you have downloaded at the step a) or [D.1 Download the latest software] and click [Open].

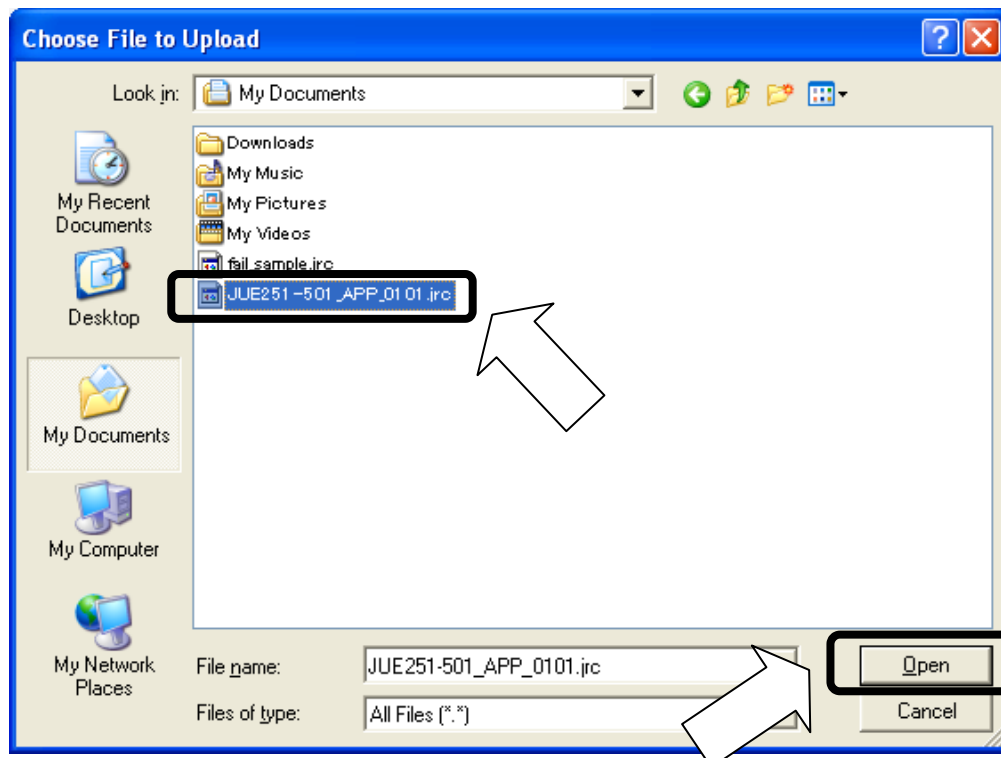

5. Click [Update] button.
 - The [Update] button changes into disable (gray).
 - Wait until the [Update] button recovered and the update was completed.

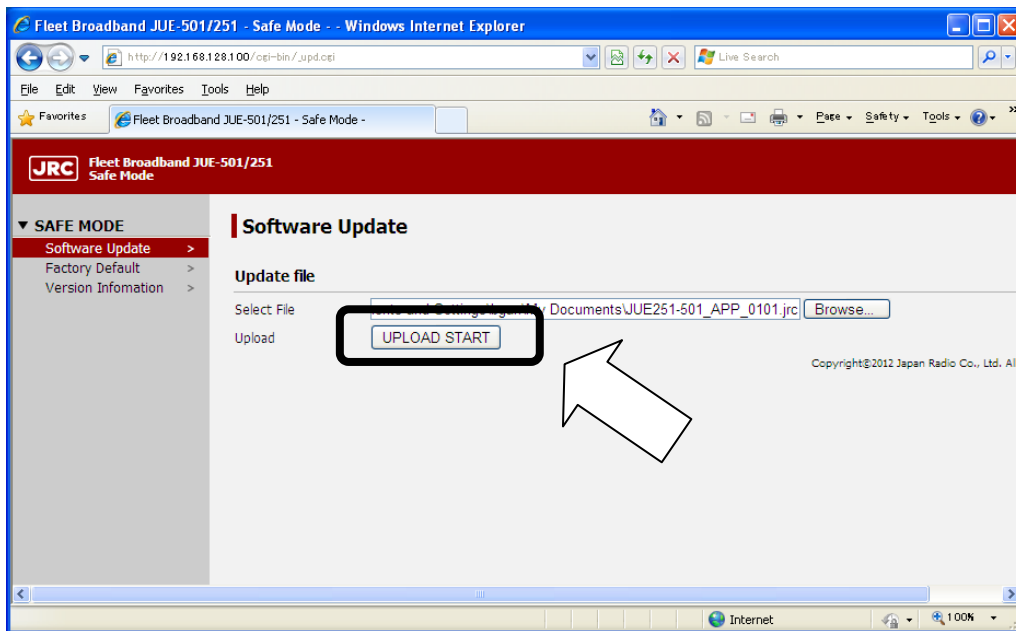

6. Check the result.

NOTE

- * Please do not operate your Web browser until the result is printed. It may take more than 3 minutes.
- * In the case of unresponsiveness in 5 minutes, please retry software updating with following page D-8 of this manual from A) to E).

- [Success] is displayed when the update finished successfully. Then, reboot your system.
- [Update Error] is displayed when the update has failed. Go to the next page.

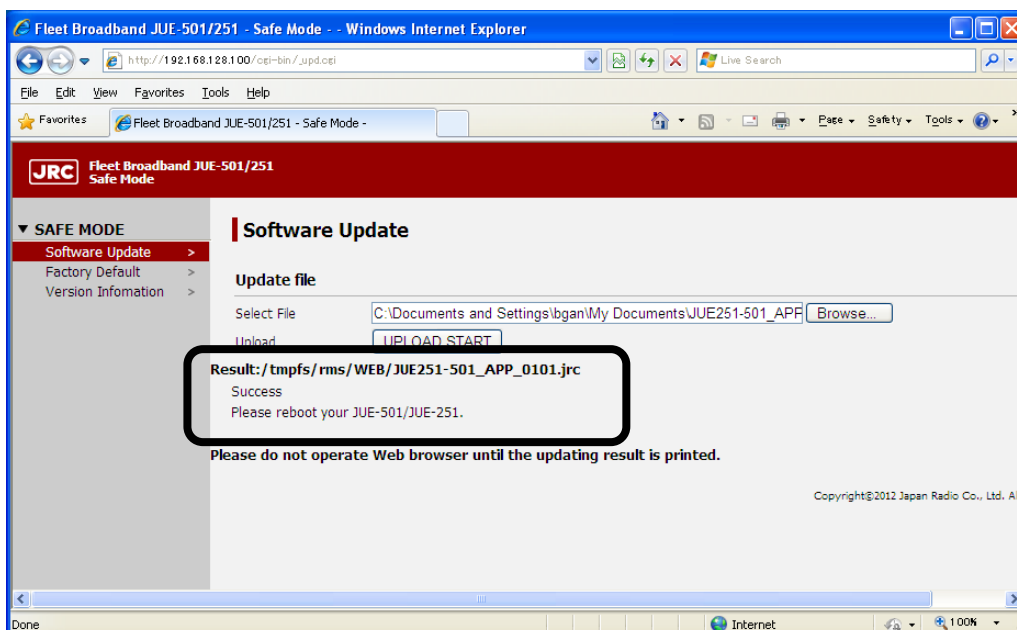

When software update is failed

Update is failed when “Update Error” is printed on your Web browser.

Check the error code below. Turn off your JUE-501/JUE-251 and retry updating by following the Software Updating Procedure in Safe Mode (on page D-8 of this manual) from A) to E).

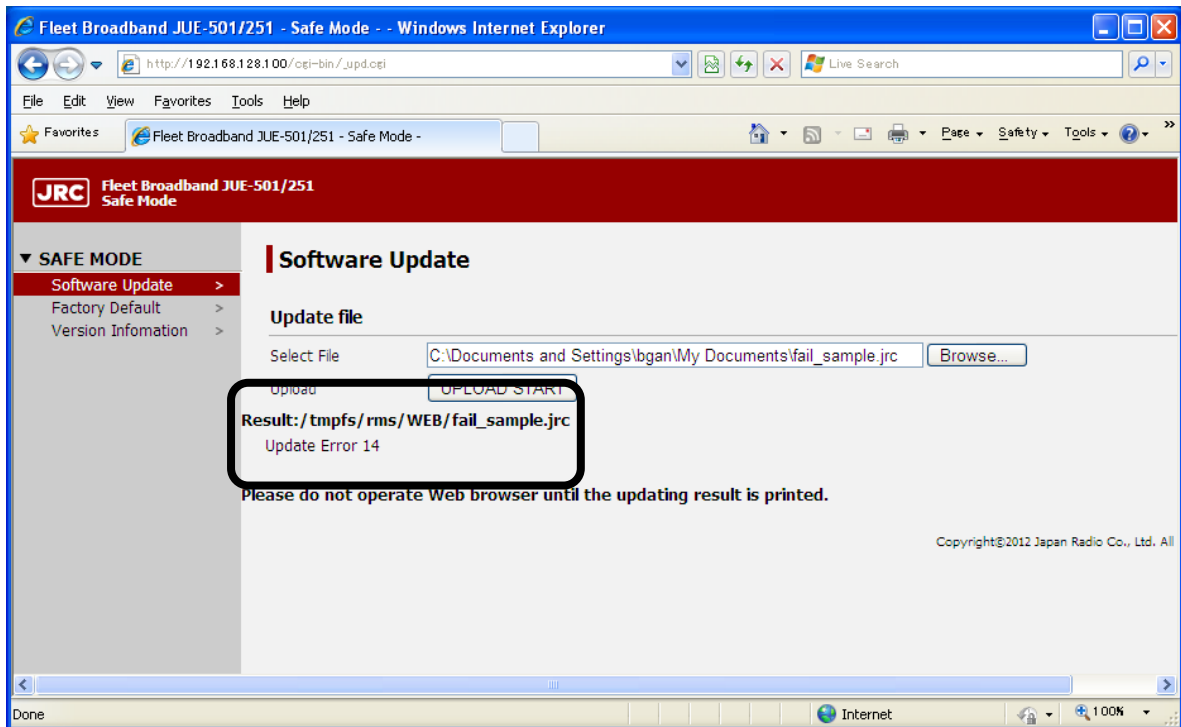

Table D.4 Software updating error code

Code	Supposed cause
1	The system is under the software updating already.
2~13 and 17	Internal error.
14~16	The file you uploaded is wrong file.
21~31	It failed in uploading the file.

Recovery procedure when software update is failed

1. Turn OFF the power supply of JUE-501/JUE-251.
2. Repeat from the 2nd step ([D.4.1 Start in Safe Mode]) of software updating procedure in safe mode (on page D-8 of this manual).

**Software downgrading procedure**

If you have any problems caused by upgrading, you can downgrade the software.

- A) Turn OFF the power supply of JUE-501/JUE-251.
- B) Repeat from the 2nd step ([D.4.1 Start in Safe Mode]) of software updating procedure in safe mode (on page D-8 of this manual). Use [JUE251-501_PKG_xxx.jrc] in CD-ROM, instead of the downloaded file [JUE251-501_PKG_xxx.jrc].

This page is remained as a blank.

Appendix E Return to the factory default

Return JUE-501/JUE-251 to the factory default with following a) to c) bellow.

a) Turn off JUE-501/JUE-251.

b) Turn on JUE-501/JUE-251 with reset button pressed. The reset button is on the back panel.

Press reset button with ball point pen, paperclip or something of that nature.

* Please do not press reset button forcefully. It may case a trouble.

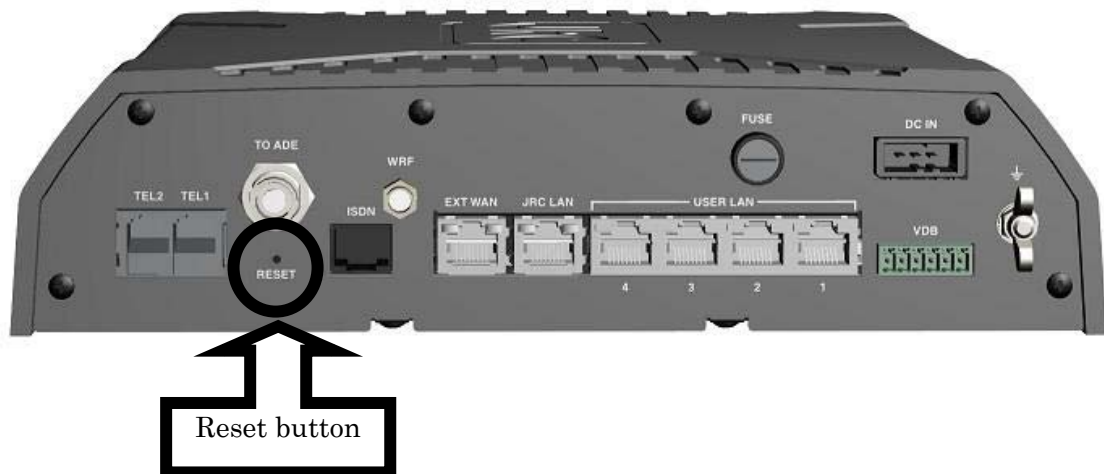

c) Release the reset button after the Ready LED on front panel lit in orange.

* Returning to the factory default is also available on Web interface with Admin users. For more information, refer to [Sec. 6.5.9 Reset to Factory Default (p6-75)].

This page is remained as a blank.

Appendix F Default value list (BDE-App 01.03)
--

Item	Default	Setting from Web Interface		
		Chapter	Title	
SMS Service Center Address (SCA)	00870772001799	6.4.3.5	Service Center Address	
Validity date of the message	1 Day		Validity	
Behavior of the message after it delivered to the destination	Class 3		Service Class	
Delivery confirmation function	Disable		Status Report	
Character Code for sending SMS	GSM7		Send Character Code	
Currency for calculating Communication fee	USD	6.4.5.2	Currency	
Communication fee for unit time (minute)	All zero		Rate for Unit	
Delivery date of the JUE-501/JUE-251	01/JAN/2012	6.5.1	Delivery Date	
Time differences from UTC	+0:00		Local Time	
Selection of satellite tracking method	Auto		Tracking	
Input from external GPS	Disable		GPS Input	
Output the Alarmpack to VDR	LAN		VDR Output	
WRF (Wide-band Radio Frequency) port	Disable		WRF	
Turn on/off the LED lamps on front panel	ON		Panel LED	
Turn on/off the Ethernet LED lamps on back panel	ON		Ethernet LED	
Blockage Area	All Disable		Blockage Area	
Use of Secret code for a call from Handset port	Disable		6.5.2.1	Handset – Secret Code
Volume level of Handset port	Normal	Handset – Voice Volume		
Making a call from Handset	Enable	Handset – Outgoing Call		
Making a call from Handset (Allowed Number)	None	Handset – Allowed Number		
Call Reception setting of Handset port	Enable	Handset – Incoming Call		
Outgoing service type of TEL1~6	Voice	TEL1~6– Outgoing Type		
Incoming service type of TEL1~6	Voice	TEL1~6– Incoming Type		
Use of Secret code for a call from TEL1~6 port	Disable	TEL1~6– Secret Code		
Volume level of TEL1~6 port	Normal	TEL1~6– Voice Volume		
Making a call from TEL1~6 port	Enable	TEL1~6– Outgoing Call		
Making a call from TEL1~6 port (Allowed Number)	None	TEL1~6– Allowed Number		
Call Reception setting of TEL1~6 port	Enable	TEL1~6– Incoming Call		
Outgoing service type of ISDN port	Voice & Fax	ISDN – Outgoing Type		
Incoming service type of ISDN port	Voice & Fax	ISDN – Incoming Type		
Making a call from ISDN port	Enable	ISDN – Outgoing Call		
Making a call from ISDN port (Allowed Number)	None	ISDN – Allowed Number		
Call Reception setting of ISDN port	Enable	ISDN – Incoming Call		
Use of Auto Answer function	Disable	6.5.2.2		Control
Targeting service type for Auto Answer function	Voice			Incoming Type
Default Extension number	000			Extension Number
Waiting time for number input	15 sec		Limit Time	
Backlight dimmer of Handset	4	6.5.3.1	Back Light	
Brightness of Handset LED lamps	4		Dimmer	
Ringer pattern of Handset	1		Ring Type	
Ringer volume of Handset	3		Ring Volume	
Voice volume of Handset	3		Voice Volume	
ON/OFF of key click sound of Handset	Enable		Click Tone	
Voice-MSN of ISDN	None	6.5.3.2	Voice-MSN	
Audio-MSN of ISDN	None		Audio-MSN	
UDI-MSN of ISDN	None		UDI-MSN	
RDI-MSN of ISDN	None		RDI-MSN	
PBX-MSN of ISDN	None		PBX-MSN	
Type of ISDN	ETSI	Service Type		

Appendix F Default value list (BDE-App 01.03)

Item	Default	Setting from Web Interface	
		Chapter	Title
IP Address of User LAN	192.168.128.100	6.5.3.3	IP Address
Subnet Mask of User LAN	255.255.255.0/24		Subnet Mask
Use of DHCP server	Enable		DHCP
Minimum allocation IP address for DHCP	192.168.128.101		DHCP Start Address
Total amount of allocatable IP address number	16		DHCP Count
IP Address of external WAN	192.168.0.4		IP Address
Subnet Mask of external WAN	255.255.255.0/24	Subnet Mask	
Use of Output 1~2	Disable	6.5.3.4	Output 1~2 - Control
Function of Output 1~2	Ring Indication		Output 1~2 - Function
Use of Input 1~2	Disable		Input 1~2 - Control
Function of Input 1~2	Ring Acknowledge		Input 1~2 - Function
Condition for the function of Input 1~2	Active High		Input 1~2 - Polarity
Service type for Output (Ring Indication)	All		Ring Indication - Type
Buzzer indication when Voice call has arrived	Enable	6.5.3.5	Option Buzzer 1~4 Voice
Buzzer indication when Fax/Audio call has arrived	Enable		Option Buzzer 1~4 Fax/Audio
Buzzer indication when UDI call has arrived	Enable		Option Buzzer 1~4 UDI
Buzzer indication when RDI call has arrived	Enable		Option Buzzer 1~4 RDI
User Level for the No.1 user	Admin	6.5.4.1	1 - Level
User Name for the No.1 user	ADMIN		1 - Name
Secret Code for the No.1 user	0001		1 - Secret Code
Restriction for the No.1 user	Disable		1 - Restriction
WAN Profile for the No.1 user	Profile 1		1 - WAN Profile
Multi Connect authority for the No.1 user	Enable		1 - Multi Connect
Quick Connect authority for the No.1 user	Enable		1 - Quick Connect
User Level for the No.2 user	Guest		2- Level
User Name for the No.2 user	GUEST		2- Name
Secret Code for the No.2 user	None		2- Secret Code
Restriction for the No.2 user	Disable		2- Restriction
WAN Profile for the No.2 user	Profile 1		2- WAN Profile
Multi Connect authority for the No.2 user	Enable		2- Multi Connect
Quick Connect authority for the No.2 user	Enable		2- Quick Connect
User Level for the No.3 or latter user	Guest		3~50 - Level
User Name for the No.3 or latter user	No Data (Unregistered)		3~50 - Name
Secret Code for the No.3 or latter user	No Data (Unregistered)		3~50 - Secret Code
Restriction for the No.3 or latter user	Disable (Unregistered)		3~50 - Restriction
WAN Profile for the No.3 or latter user	Disable (Unregistered)		3~50 - WAN Profile
Multi Connect authority for the No.3 or latter user	Disable (Unregistered)		3~50 - Multi Connect
Quick Connect authority for the No.3 or latter user	Disable (Unregistered)	3~50 - Quick Connect	
IP Address for the device (from No.1 to No.50)	No Data (Unregistered)	6.5.4.2	1~50 - IP
Name of the device (from No.1 to No.50)	No Data (Unregistered)		1~50 - Device Name
Restriction for the device (from No.1 to No.50)	No Data (Unregistered)		1~50 - Restriction
WAN Profile for the device (from No.1 to No.50)	Disable (Unregistered)		1~50 - WAN Profile
Multi Connect authority for the device (from No.1 to No.50)	Disable (Unregistered))		1~50 - Multi Connect
Quick Connect authority for the device (from No.1 to No.50)	Disable (Unregistered)		1~50 - Quick Connect

Item	Default	Setting from Web Interface	
		Chapter	Title
Restriction Name	Restriction 1~5	6.5.4.3	Restriction Name
Permission for each service type	Unlimited		Permission
Limitation value for each Service Type	No Data (Unregistered)		Time/Size
Reset Cycle for the limitation count	Manual		Term
Updated date	No Data (Unregistered)		Closing Day
Name of the Profile	Profile 1~5	6.5.5.1	Group Name
Service Type for PS connection	Standard&Streaming		Service Type
Authority of editing APN manually	Permit		Edit
APN for PS connection	SIM default		APN
APN User name and Password	No Data (Unregistered)		APN User / Password
Global IP Address for PS connection	Dynamic		Global IP
Connection mode	1 by 1 NAT		Connection Mode
Use of Packet Detect Activate function	Disable		Packet Detect Activate
Use of WAN Filter	Disable		WAN Filter
Use of VPN	Disable		VPN
Service type for Secondary Service	Standard&Streaming		Secondary Service Type
Profile used for Always Activate	Disable	6.5.5.3	1~3 – Profile
Local IP Address connected by Always Activate	No Data (Unregistered)		1~3 – Local IP
Service Type used by Always Activate	Standard (fix)		1~3 – Service
Use of Remote Activate	Disable	6.5.5.4	Remote Activate
User name of Remote Activate	No Data (Unregistered)		User
Password of Remote Activate	No Data (Unregistered)		Password
Profile used for Remote Activate	Profile 1		Profile
Local IP Address used by Remote Activate	No Data (Unregistered)		Local IP
Service Type used by Remote Activate	Standard (fix)		Service
Name of LAN Group	Group 1~5	6.5.5.5	Group Name
Range of LAN Group	VLAN 1		LAN Group
Setting for DMZ	Disable		DMZ
Setting for Port Forward	Disable		Port Forward
Port Tagging setup for User LAN (Port1~4)	VLAN1 for all port	6.5.5.6	Port 1~4
Use of VLAN 1	Enable		VLAN1 – VLAN
IP Address of VLAN1	192.168.128.100		VLAN1 – IP Address
Subnet Mask of VLAN1	255.255.255.0/24		VLAN1 – Subnet Mask
Use of DHCP for VLAN1	Enable		VLAN1 – DHCP
Minimum allocation IP address for DHCP	192.168.128.101		VLAN1 – Start IP
Total amount of allocatable IP address number	16		VLAN1 – Count
Use of VLAN 2~4	Disable		VLAN2~4 – VLAN
IP Address of VLAN2~4	No Data (Unregistered)		VLAN2~4 – IP Address
Subnet Mask of VLAN2~4	No Data (Unregistered)		VLAN2~4 – Subnet Mask
Use of DHCP for VLAN2~4	Disable		VLAN2~4 – DHCP
Minimum allocation IP address for DHCP	No Data (Unregistered)		VLAN2~4 – Start IP
Total amount of allocatable IP address number	No Data (Unregistered)		VLAN2~4 – Count
Use of MAC Filter	Disable		MAC Filter
IP Address allocated by Static DHCP	No Data (Unregistered)	6.5.5.7	Setting List – IP Address
Targeting MAC address for Static DHCP	No Data (Unregistered)		Setting List – MAC Address

Appendix F Default value list (BDE-App 01.03)

Item	Default	Setting from Web Interface	
		Chapter	Title
Target IP Address for Routing (No.1~No.20)	No Data (Unregistered)	6.5.5.8	Target IP
Subnet Mask for Routing (No.1~No.20)	255.255.255.0/24 (Unregistered)		Subnet Mask
Gateway IP Address for Routing (No.1~No.20)	No Data (Unregistered)		Gateway IP
Use of WAN Selector	Disable	6.5.5.9	WAN Selector
Destination IP Address for sending ping packet	No Data (Unregistered)		Ping Destination
Gateway IP Address for External WAN	192.168.0.1		Gateway IP
Maximum connecting time of Handset port (Auto DCN.)	Disable (not disconnected)	6.5.6	Handset
Maximum connecting time of TEL1 port (Auto DCN.)	Disable (not disconnected)		TEL1
Maximum connecting time of TEL2 port (Auto DCN.)	Disable (not disconnected)		TEL2
Maximum connecting time of TEL3 port (Auto DCN.)	Disable (not disconnected)		TEL3
Maximum connecting time of TEL4 port (Auto DCN.)	Disable (not disconnected)		TEL4
Maximum connecting time of TEL5 port (Auto DCN.)	Disable (not disconnected)		TEL5
Maximum connecting time of TEL6 port (Auto DCN.)	Disable (not disconnected)		TEL6
Maximum connecting time of TELISDN port (Auto DCN.)	Disable (not disconnected)		ISDN
Maximum connecting time of Streaming IP connection (Auto DCN.)	Disable (not disconnected)		Streaming
Maximum connecting time of Standard IP connection (Auto DCN.)	Disable (not disconnected)		Standard
Request for PIN Code	Disable		6.5.7
Facility Lock	All Disable	Facility Lock - Change Status	
Use of Secondary SIM	Disable	Secondary SIM	
Use of Syslog	Disable	6.5.11	Enable/Disable
Log Server IP Address	No Data (Unregistered)		Syslog Server IP
Level for logging	ERR		Log Level

Appendix G JUE-501/251 VPN setting

JUE-501/JUE-251 supports IPsec VPN. JUE-501/JUE-251 Web Menu System allows user to set parameters only for remote access. Others are provided as fixed value.

JUE-501/JUE-251 VPN specification is shown below.

Fig JUE-501/251 VPN Specification

	Setting parameter	Spec/Value
1)	IPsec protocol mode	ESP tunnel (Network-to-Network VPN)
2)	IPsec encryption mode	3DES(Triple DES) AES(Advanced Encryption Standard)
3)	IPsec authentication method	HMAC_SHA1 HMAC_MD5
4)	IPsec data compression mode	Deflate
5)	IKE(Internet Key Exchange) mode	Main, Aggressive
6)	IKE encryption mode	3DES
7)	IKE Authentication	Pre-Shared Key
8)	Diffie-Hellman group	Group 2 (1,024 bit)
9)	NAT traversal	Force (always enabled)
10)	IKE retry interval	5[sec]
11)	IKE retry number	5
12)	IKE Phase1 timeout	20[sec]
13)	IKE Phase2 timeout	20[sec]
14)	IKE Lifetime	3600[sec]
15)	IPsec Lifetime	3600[sec]

This page is remained as a blank.

Appendix H How to connect PPPoE Connection

H.1 About PPPoE Connection

JUE-501/JUE-251 provides PPPoE server. You can use the Inmarsat Standard IP service via PPPoE connection on your PPPoE client—PC or Router.

Set PPPoE server information listed below to your PPPoE client.

Parameter	Configuration
User Name	void
Password	void
Authentication method	“Any” or “CHAP”

NOTE

- Your PPPoE client has a possibility to receive invalid packets from the internet because PPPoE connection assigns the global IP address allocated from the inmarsat network directly on your PC or router.
- WAN Filter is not applied for PPPoE connections.
- The PS connection is made by PPPoE client’s connecting/disconnecting action.
- APN settings for PPPoE Connection (APN name, APN username and password) are set on the “Network->WAN Profile” screen. WAN profile of “GUEST” user is applied for PPPoE connection. For more information, refer to [Sec.6.5.5.1 Set WAN Profile] and [Sect. 6.5.4.1 Register Users].
- PPPoE connection on Streaming IP service is not available. Confirm that “Streaming only” is not assigned to the “GUEST” user’s WAN Profile.
- PPPoE connections always use Inmarsat Standard IP service even if WAN Selector of JUE-501/JUE-251 is enabled.

H.2 Connect your PPPoE Client to User LAN port

Connect your PPPoE client (PC or Router) to User LAN port with LAN cable.

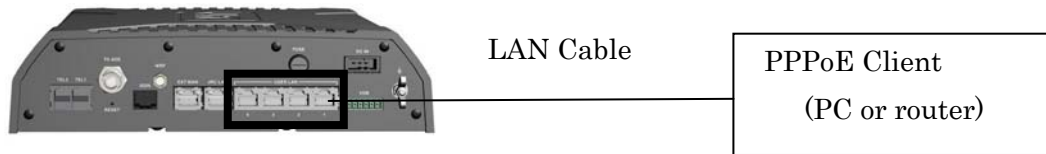

Fig.H.2.1 PPPoE Connection diagram

For more information about connecting PC or router to the main unit, refer to [Sec.6.1 Connect Your PC to JUE-501/JUE-251].

H.3 Settings for PPPoE Client (Windows XP)

(1) Click [Start] and select [Control Panel].



Fig.H.3.1 Windows XP Start Menu

(2) Click [Network and Internet Connections].

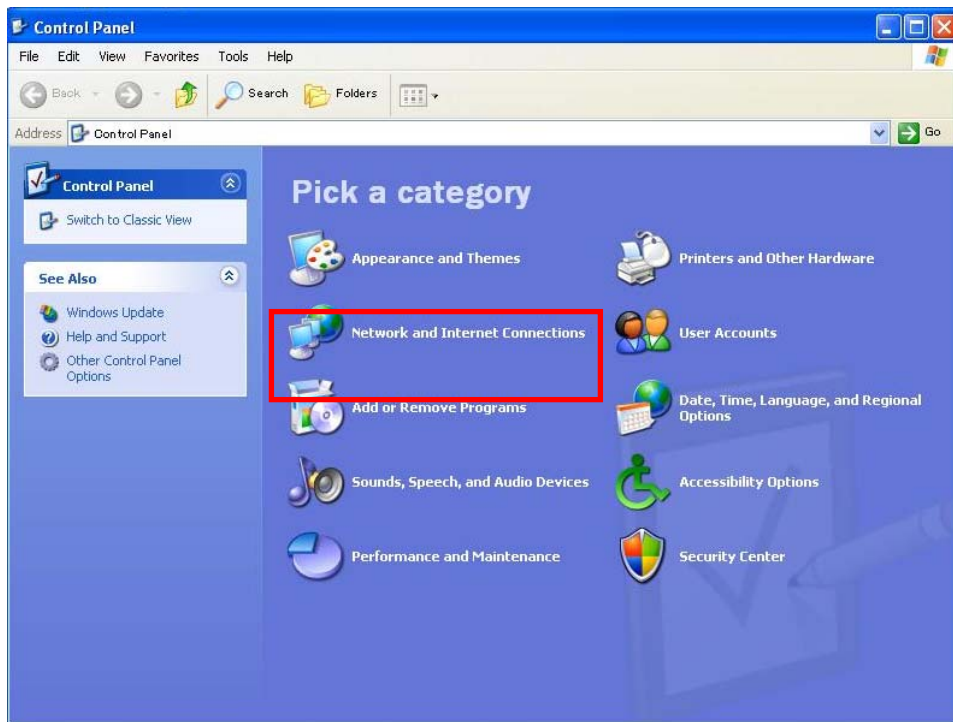

Fig.H.3.2 Control Panel Menu

(3) Click [Set up or change your Internet connection].

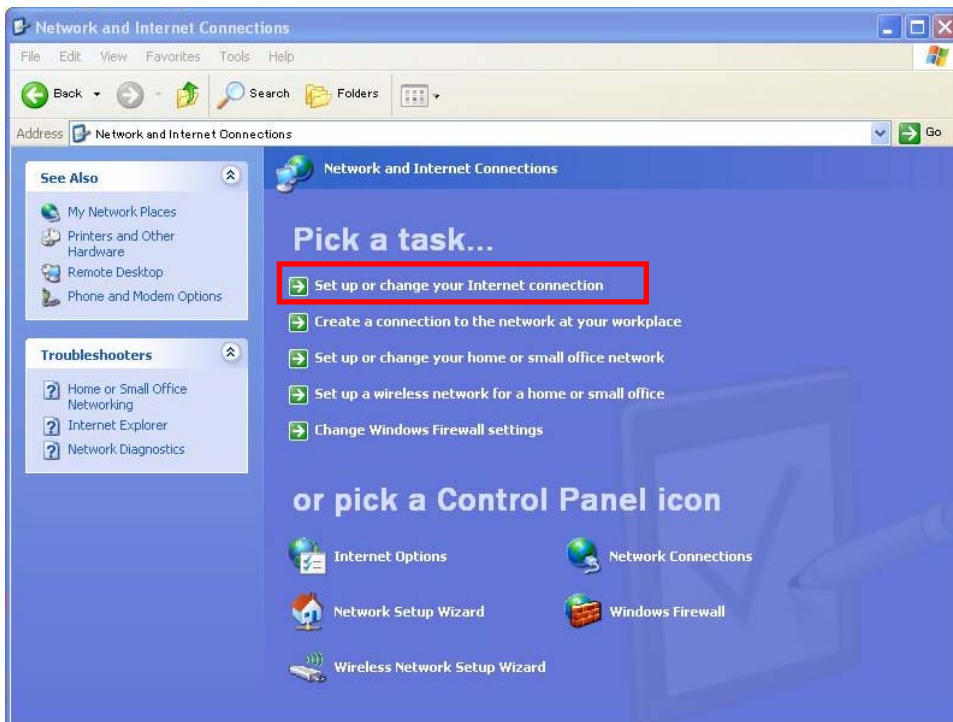

Fig.H.3.3 Network and Internet Connections Menu

Appendix H How to connect PPPoE Connection

(4) [Internet Properties] dialog appears. Select [Connections] tab and click [Setup].

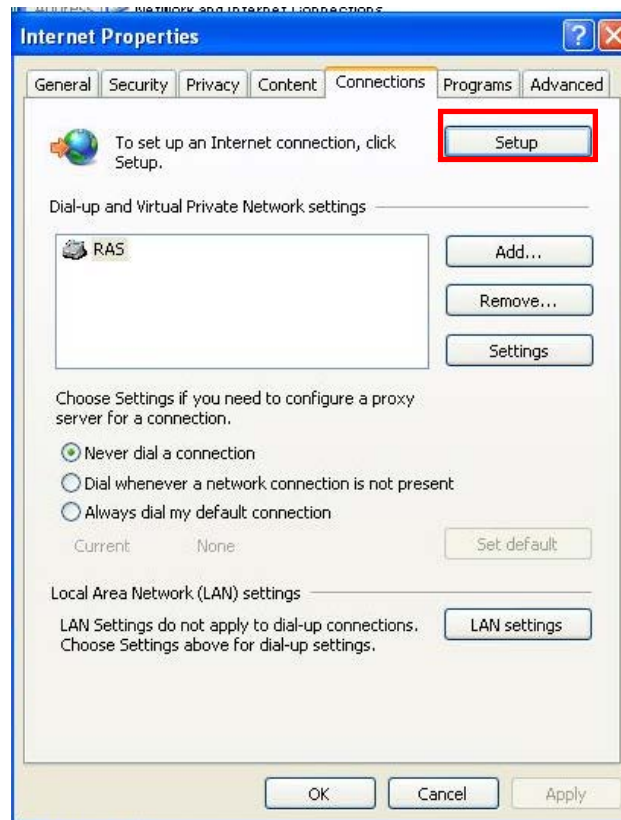

Fig.H.3.4 Internet Properties Menu

(5) [New Connection Wizard] appears. Click [Next.]



Fig.H.3.5 New Connection Wizard

- (6) Select [Connect to the Internet], and then click [Next].

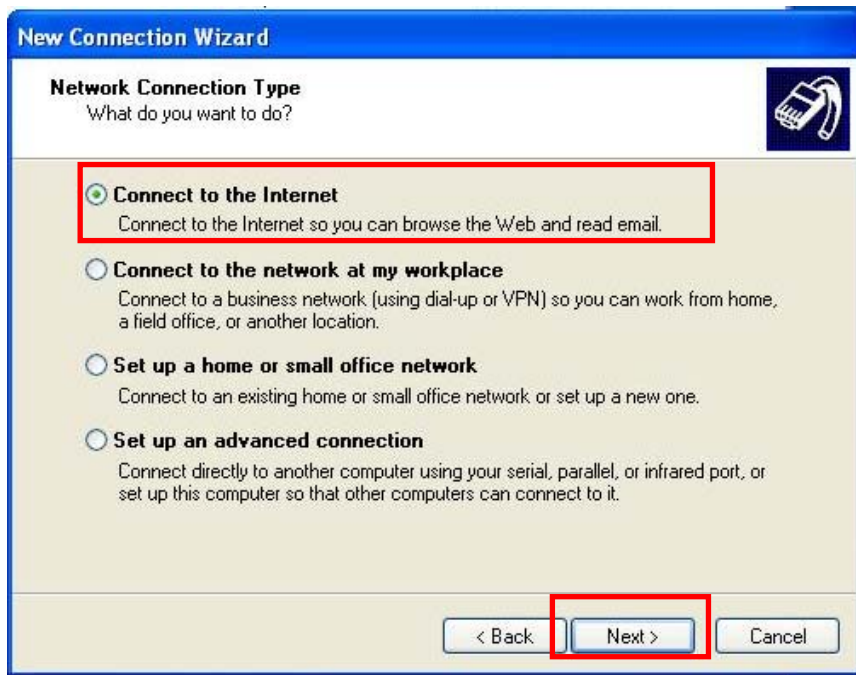

Fig.H.3.6 Network Connection Type Menu

- (7) Select [Set up my connection manually], and click [Next].

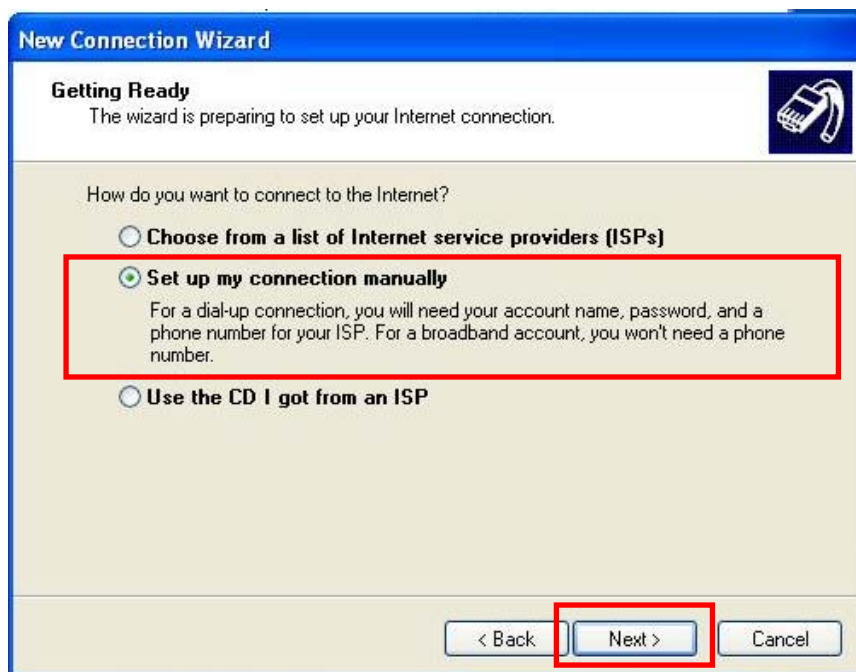

Fig.H.3.7 Getting Ready Menu

- (8) Select [Connect using a broadband connection that requires a user name and password], and click [Next].

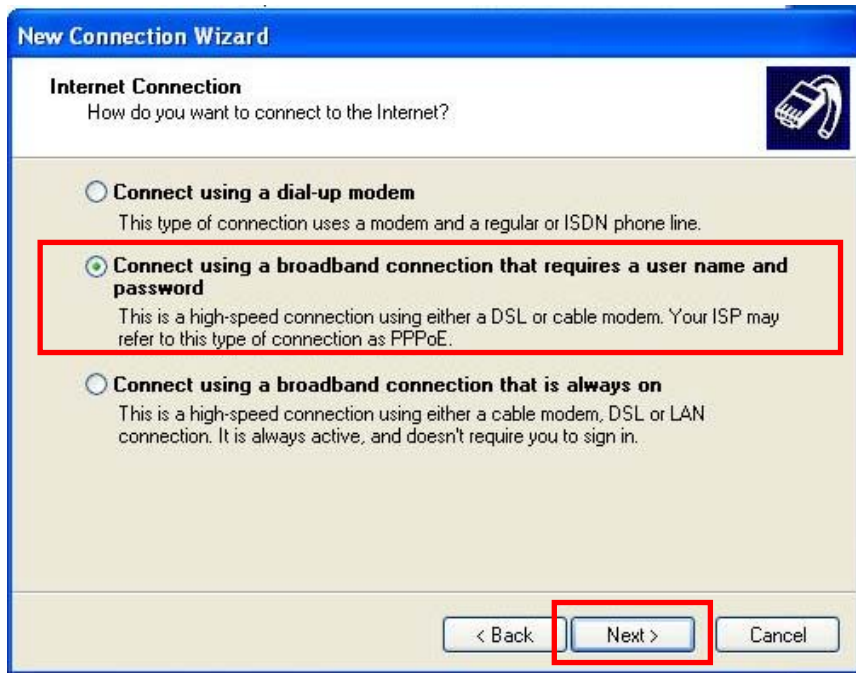

Fig.H.3.8 Internet Connection Menu

- (9) Enter an arbitrary [ISP Name], and click [Next].

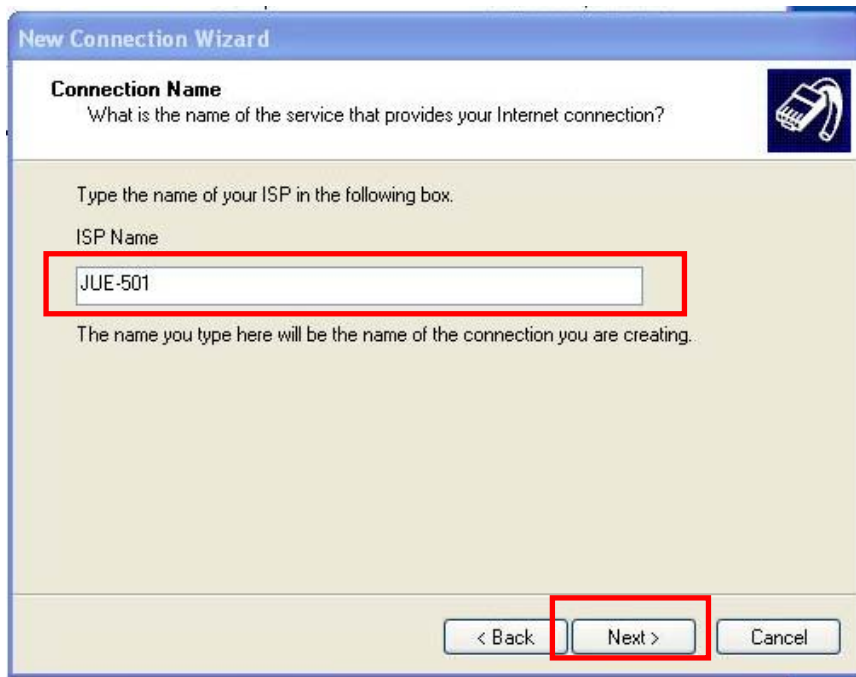

Fig.H.3.9 Connection Name

(10) Enter [User Name] and [Password] and click [Next].

Parameter	Configuration
User Name	void
Password	void

If you need PPPoE connection as default internet connection, check [Make this the default Internet connection] before clicking [Finish] button.



Fig.H.3.10 Internet Account Information

Remarks

If your PPPoE client is not Windows PC, “PPP Authentication method” may be required. Set “PPP Authentication method” to [any] or [CHAP].

(11) Click [Finish]

If you need a shortcut icon on your desktop, check [Add a shortcut to this connection to my desktop] before clicking [Finish] button.



Fig.H.3.11 Completing the New Connection Wizard

H.4. Connection and Disconnection from your PPPoE client (Windows XP)**H.4.1 Connect PPPoE**

(1) Click [Start], and select PPPoE connection you have made.

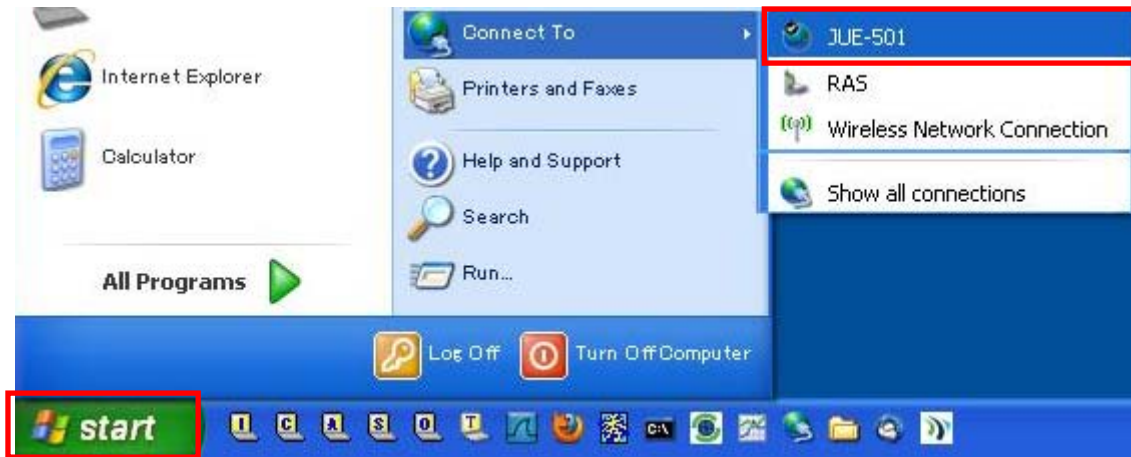

Fig.H.4.1.1 Windows XP Start menu

(2) [Connect] dialog will appear. And then click [Connect].



Fig.H.4.1.2 Connect menu

- (3) [Connecting] dialog appears and JUE-501/JUE-251 starts Standard IP connection through PPPoE.



Fig.H.4.1.3 Connecting Dialog

- (4) An information message will be displayed on the task tray after the connection has been established.



Fig.H.4.1.4 Connected Dialog

H.4.2 Disconnect PPPoE

- (1) Make a right-click on your PPPoE-connection-icon, and select [Disconnect]. And then, the PPPoE connection will be disconnected.

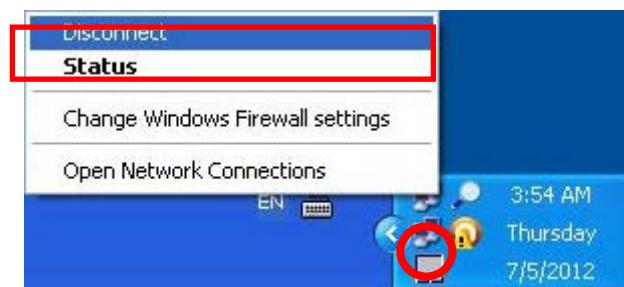
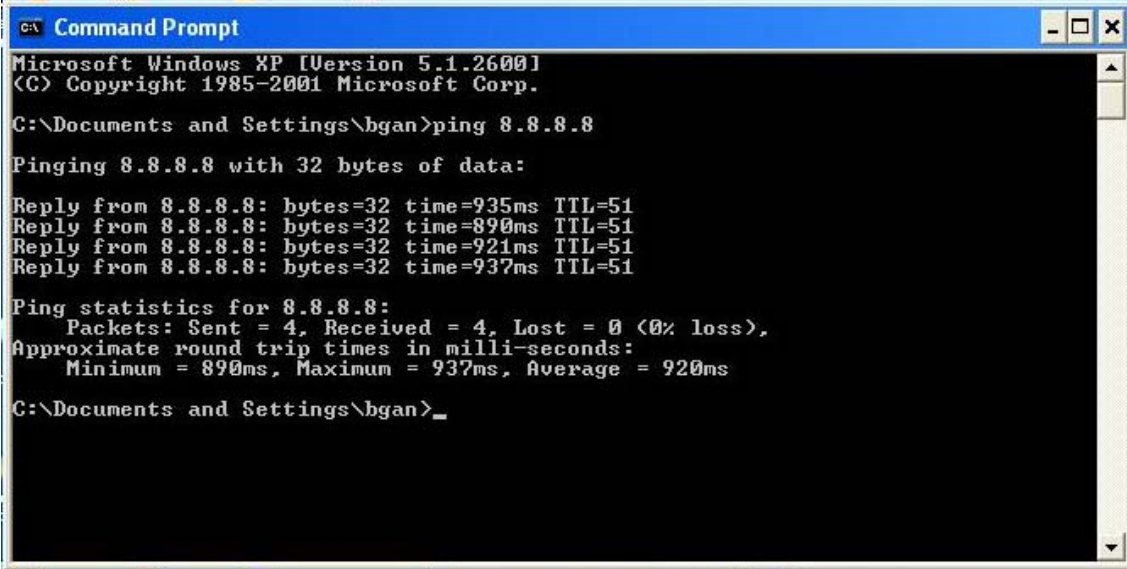

Fig.18 Disconnect Dialog

H.4.3. Check the PPPoE connection

Check the PPPoE connection by sending ping packets or browsing Web pages.

If you cannot receive ping packets nor can browse Web pages, disconnect PPPoE connection and retry PPPoE connection procedure.



```
Microsoft Windows XP [Version 5.1.2600]
(C) Copyright 1985-2001 Microsoft Corp.

C:\Documents and Settings\bgan>ping 8.8.8.8

Pinging 8.8.8.8 with 32 bytes of data:

Reply from 8.8.8.8: bytes=32 time=935ms TTL=51
Reply from 8.8.8.8: bytes=32 time=890ms TTL=51
Reply from 8.8.8.8: bytes=32 time=921ms TTL=51
Reply from 8.8.8.8: bytes=32 time=937ms TTL=51

Ping statistics for 8.8.8.8:
    Packets: Sent = 4, Received = 4, Lost = 0 (0% loss),
    Approximate round trip times in milli-seconds:
        Minimum = 890ms, Maximum = 937ms, Average = 920ms

C:\Documents and Settings\bgan>_
```

Fig.H.4.3.1 Windows Command Prompt

This page is remained as a blank.

Appendix I FB LaunchPad Installation Procedure

Note

- Launch Pad can be running on Windows XP/Vista/7 32bit.
- If the FB LaunchPad 1.0.x version or 1.1.x version is installed to your PC, uninstall it prior to this installation.

I.1. If there is no FB LaunchPad already installed.

1. Double-click the icon to open the FB LaunchPadInstaller.exe, which is stored in the attached CD-ROM:



2. Following screen is displayed when setup installation is started:

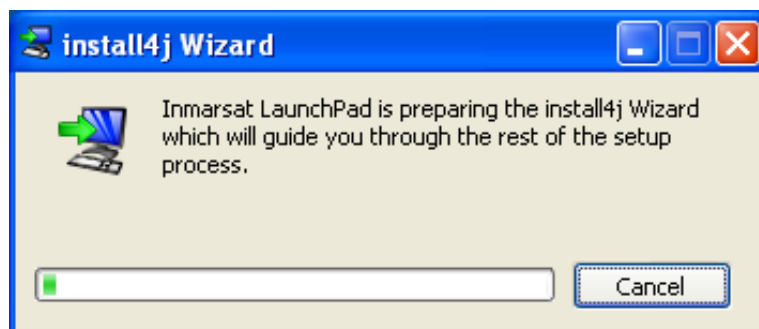

3. Following screen is displayed when setup installation is completed. Click the radio button next to "I accept the agreement", then click **Next**.

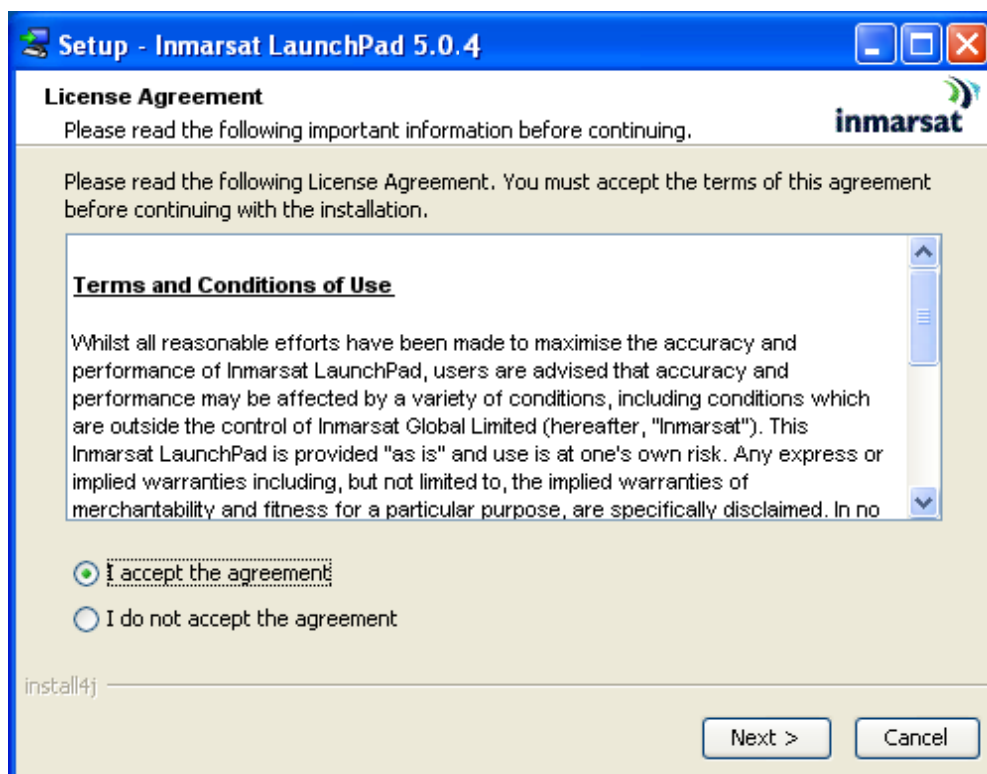

4. Select the edition. Click the radio button next to "Personal Edition", then click **Next**.

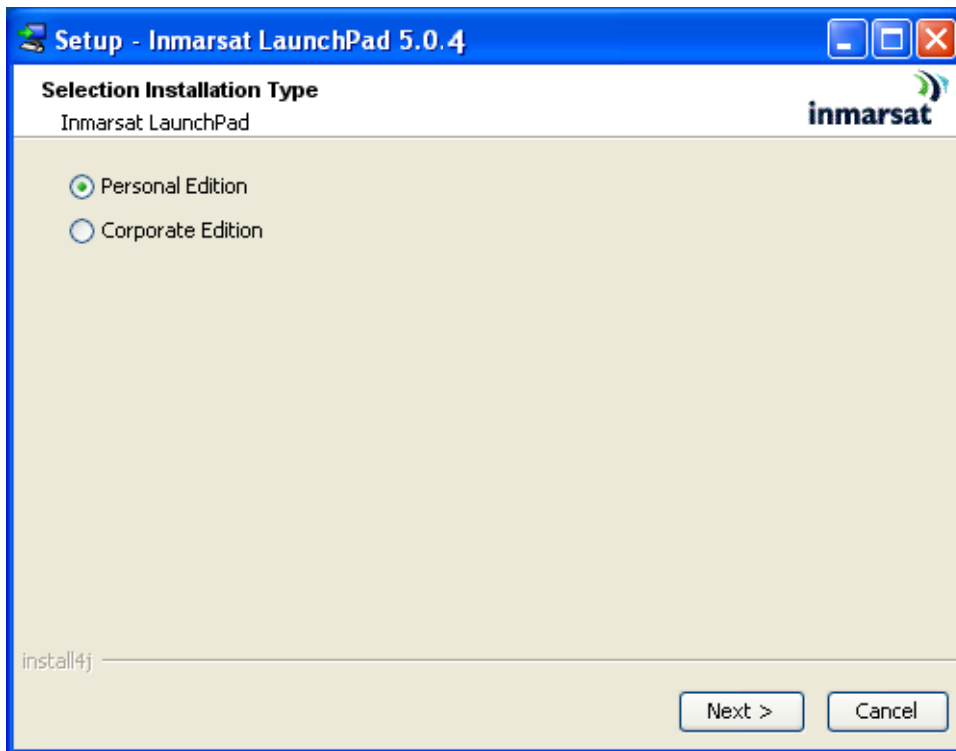

5. Select the install folder. Click **Next**.

Note

Don't change the default install folder.

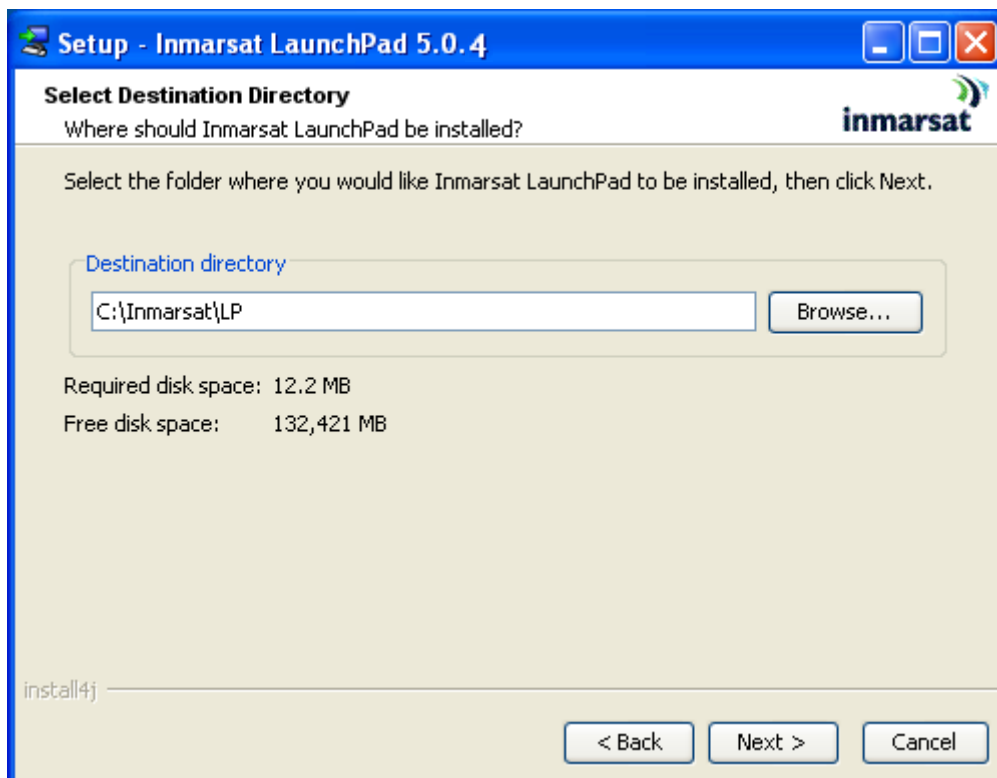

6. Click **Next**.

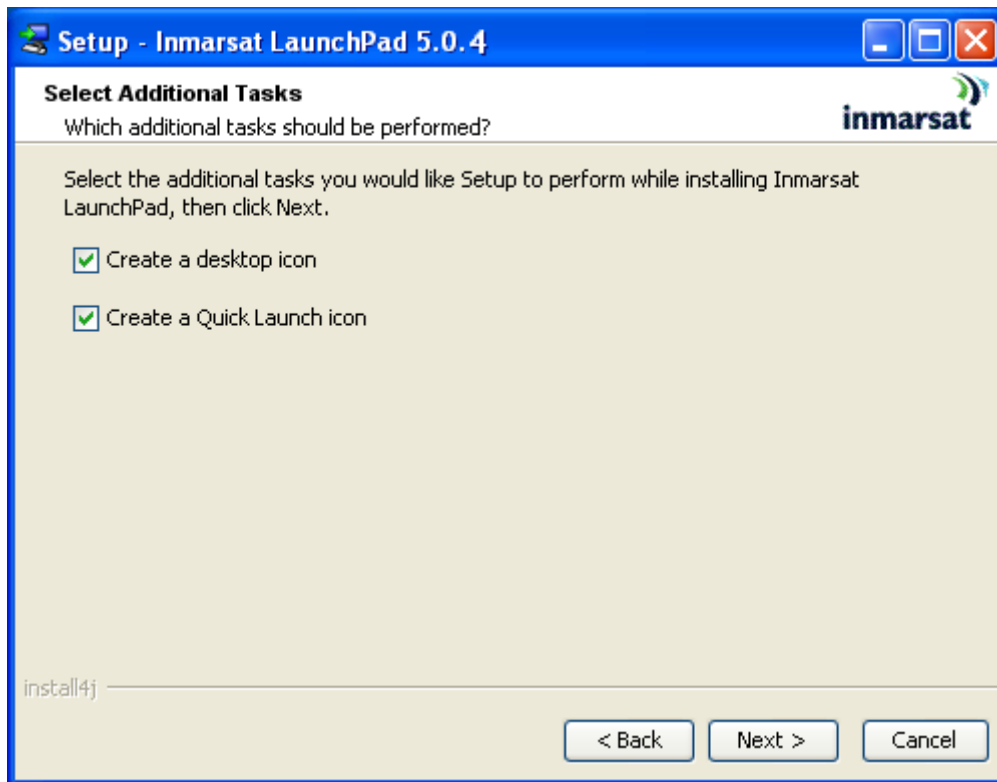

7. Following screen is displayed and Pre-installation summary is shown. Click **Install** if the summary is acceptable.

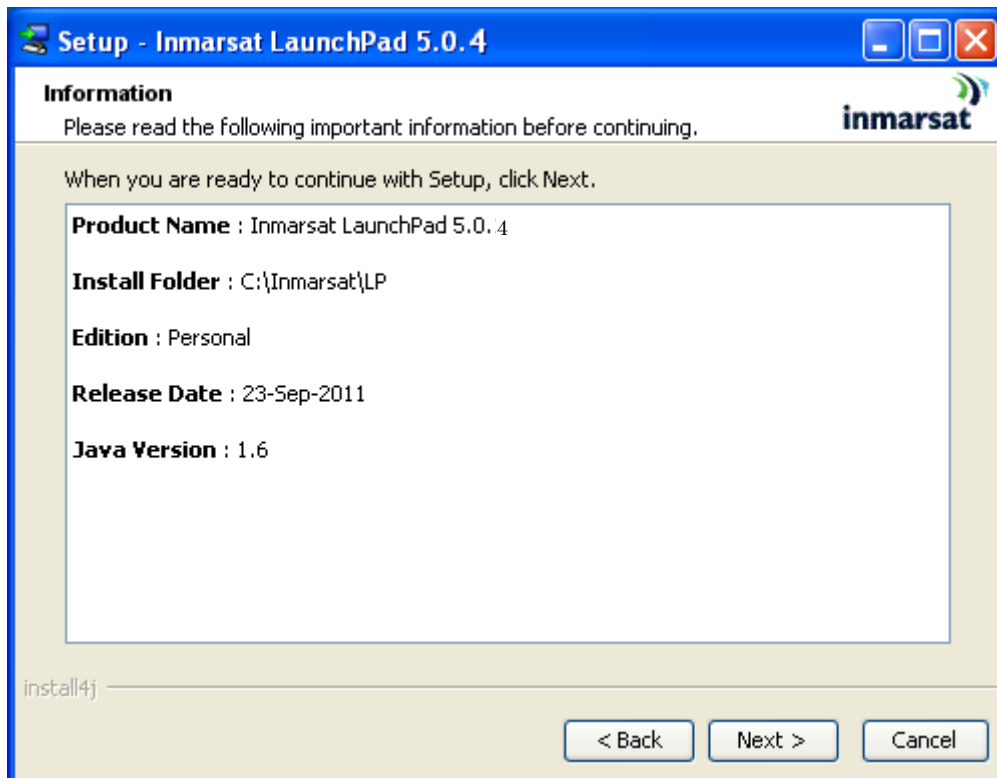

8. Following screen is displayed when installation is started.

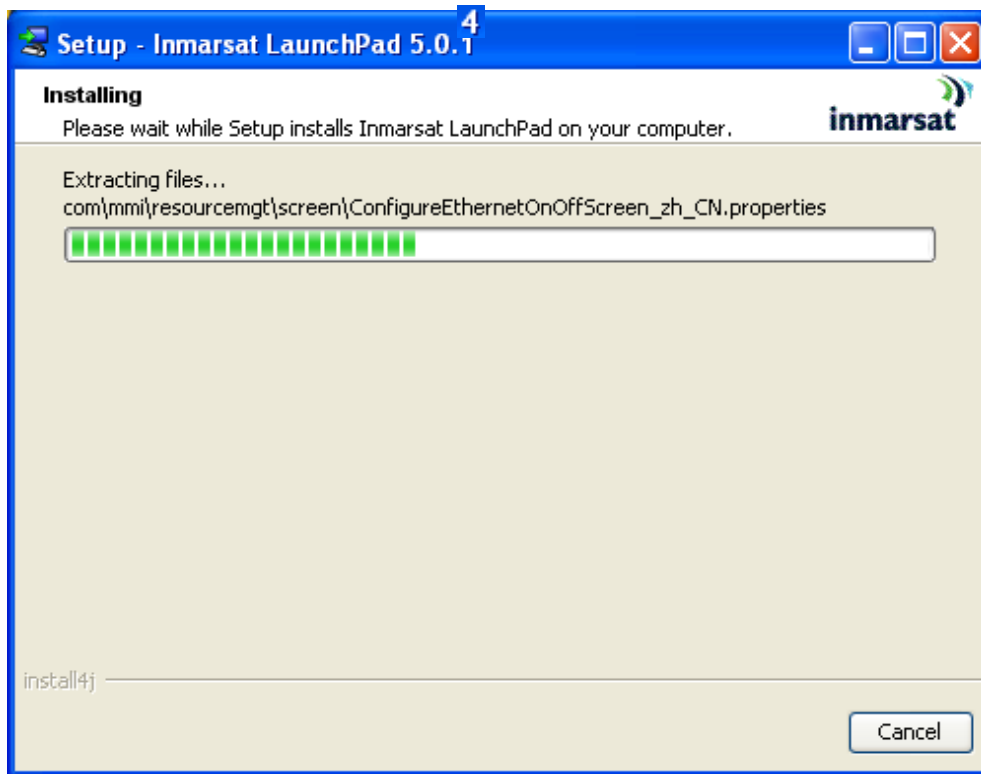

9. Following screen is displayed when the installation is completed. Click **Finish** to close the installer. Now, FB LaunchPad installation is completed.

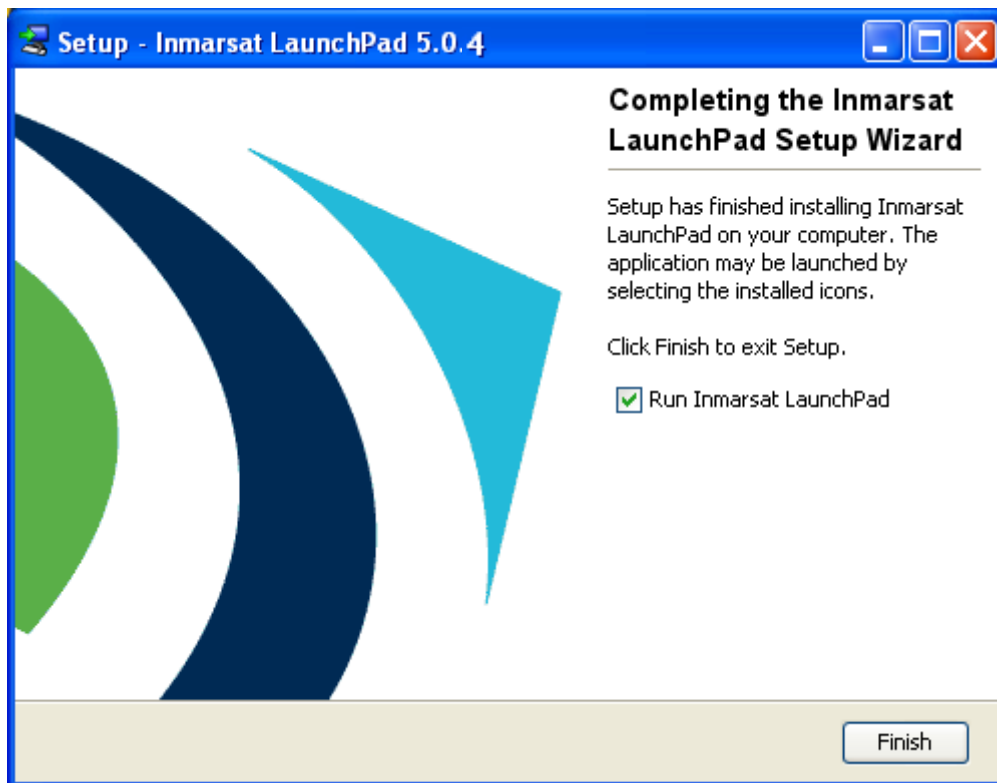

I .2. If FB LaunchPad 1.4.X version is already installed

The user data in the LaunchPad later than or equal to 1.4.0 version can be retained by this procedure.

1. Double-click the icon to open the FB LaunchPadInstaller.exe, which is stored in the attached CD-ROM:



2. Following screen is displayed when setup installation is started:

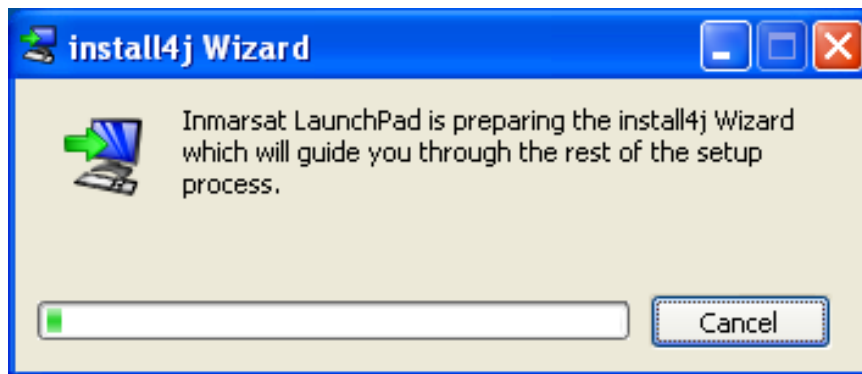

3. Following screen is displayed when setup installation is completed. Click the radio button next to "I accept the agreement", then click **Next**.

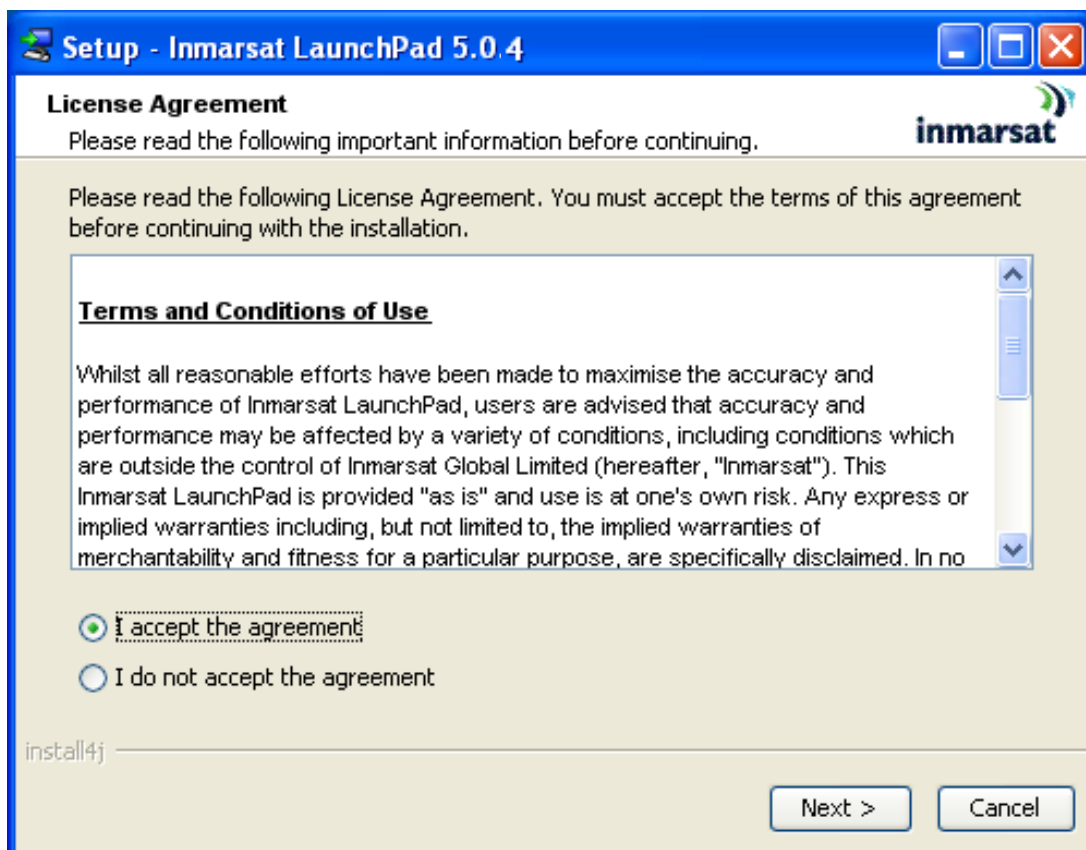

4. Select “Yes”. Uninstaller will activate to uninstall the old version.

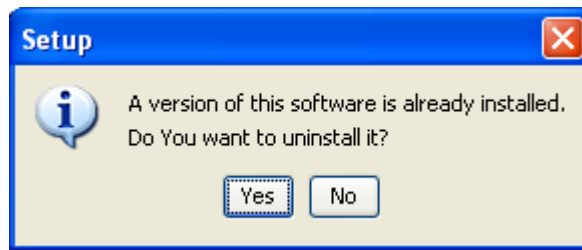

5. Click ”Yes” to retain the current data.

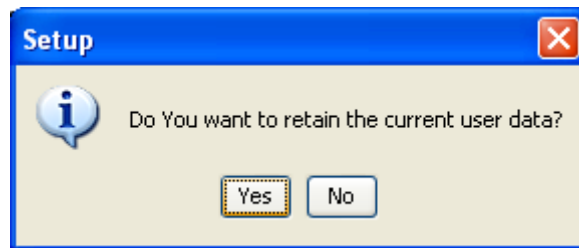

6. Select the edition. Click the radio button next to ”Personal Edition”, then click **Next**.

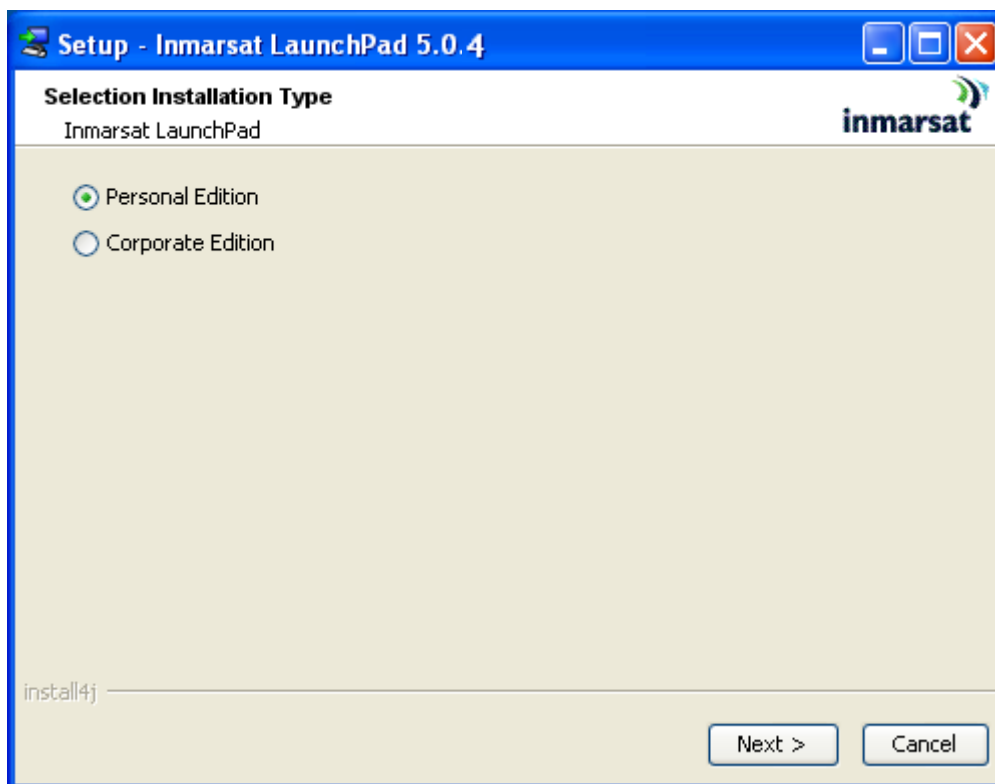

7. Select the install folder. Click **Next**.

Note

Don't change the default install folder.

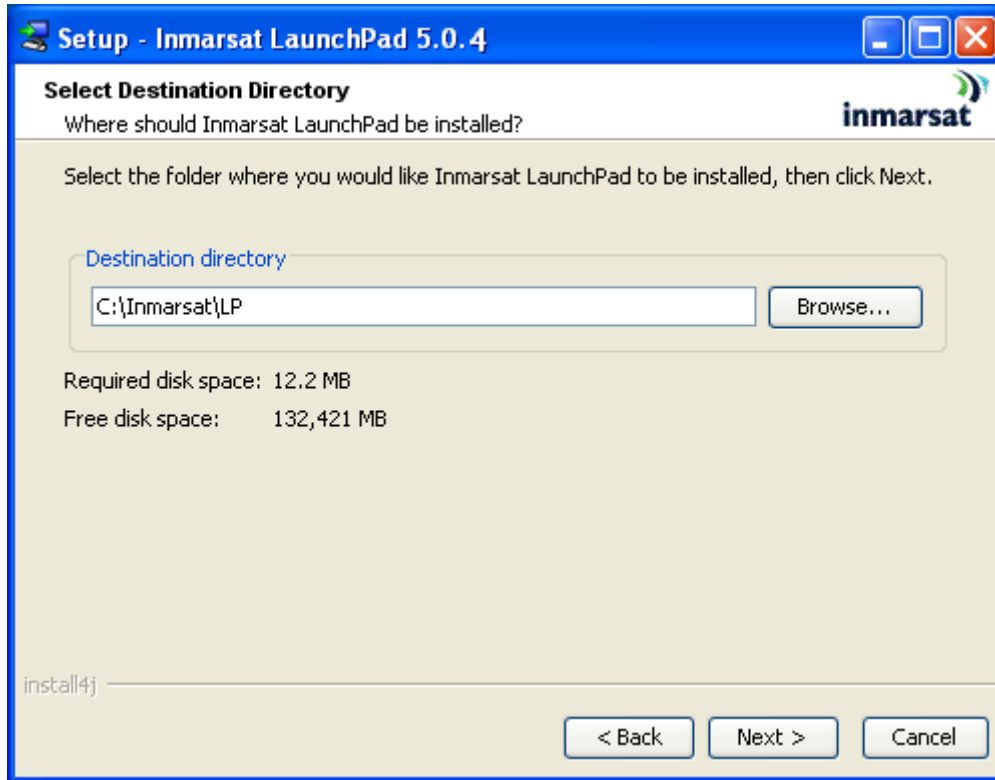

8. Click **Next**.

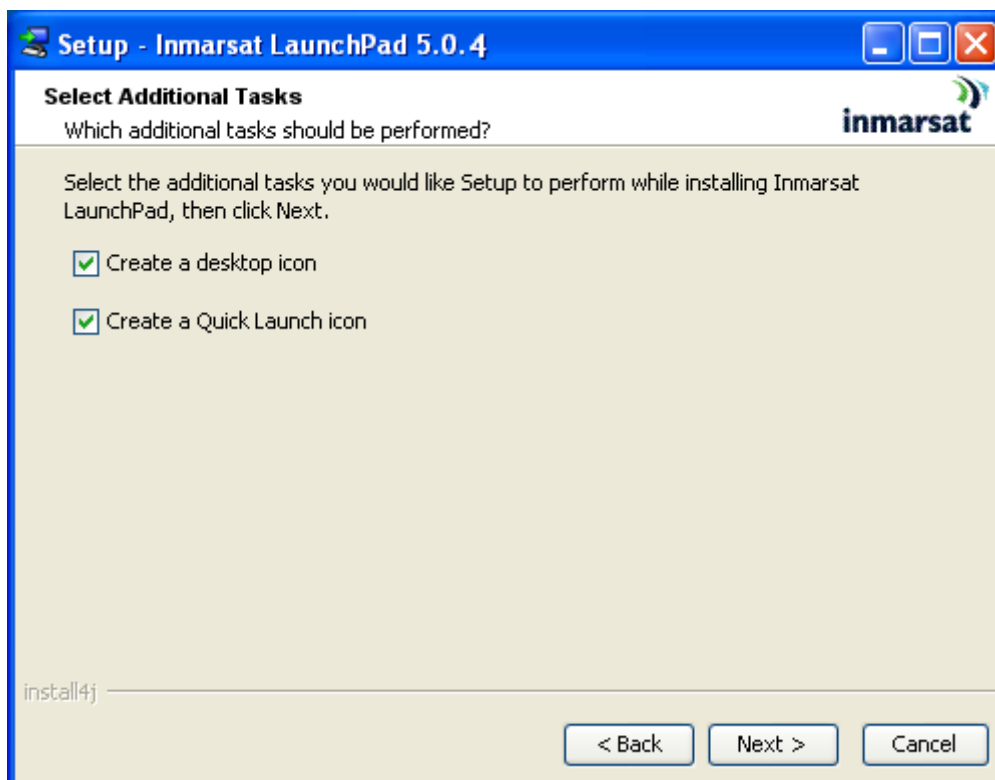

Appendix I FB LaunchPad Installation Procedure

9. Following screen is displayed and Pre-installation summary is shown. Click **Install** if the summary is acceptable.

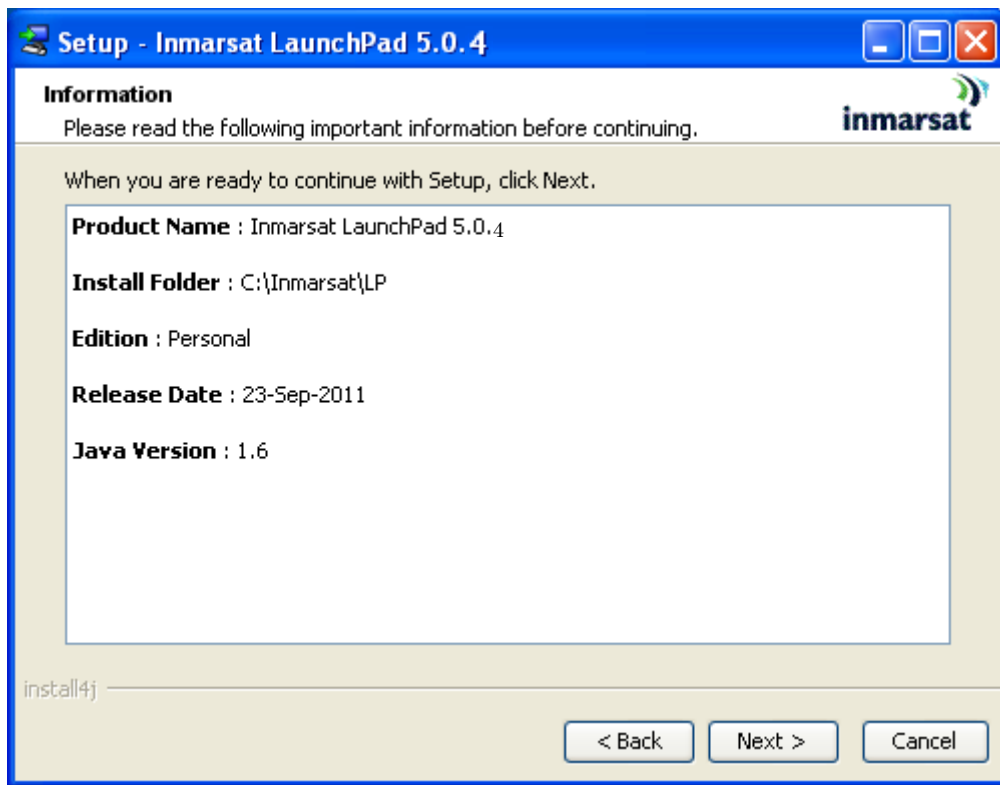

10. Following screen is displayed when installation is started.

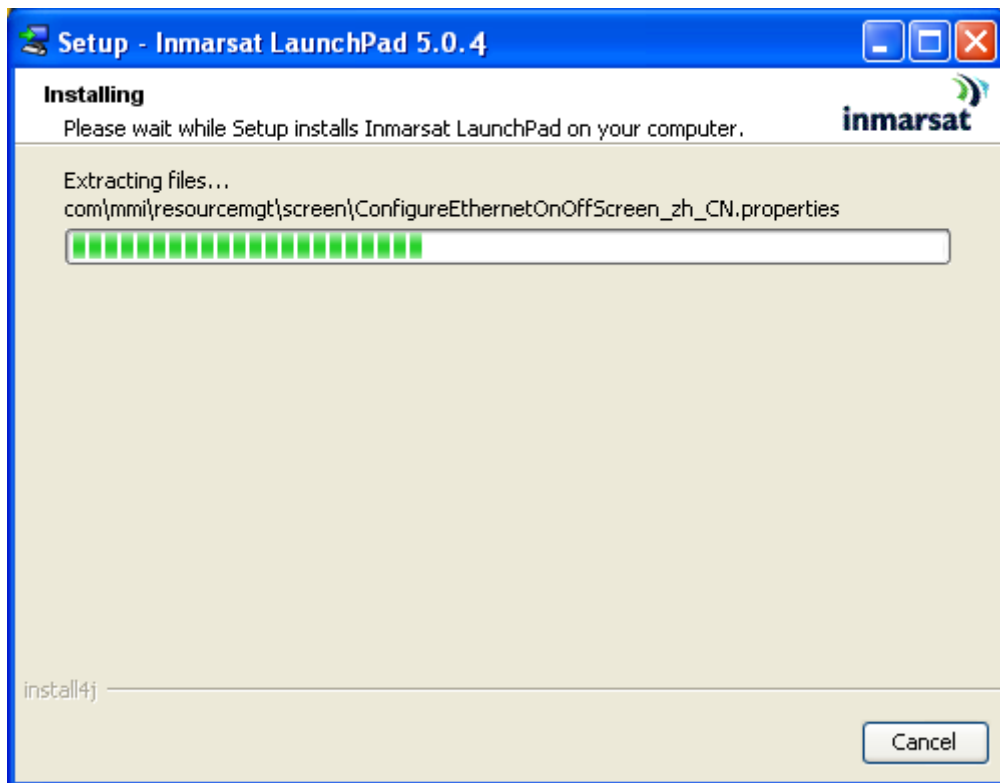

11. Following screen is displayed when the installation is completed. Click **Finish** to close the installer. Now, FB LaunchPad installation is completed.



This page is remained as a blank.

Appendix J Use LaunchPad

This section explains how to use LaunchPad. Install the LaunchPad into your PC from attached CD-ROM, before you use LaunchPad. (For details, refer to “Appendix I FB LaunchPad Installation Procedure”.)

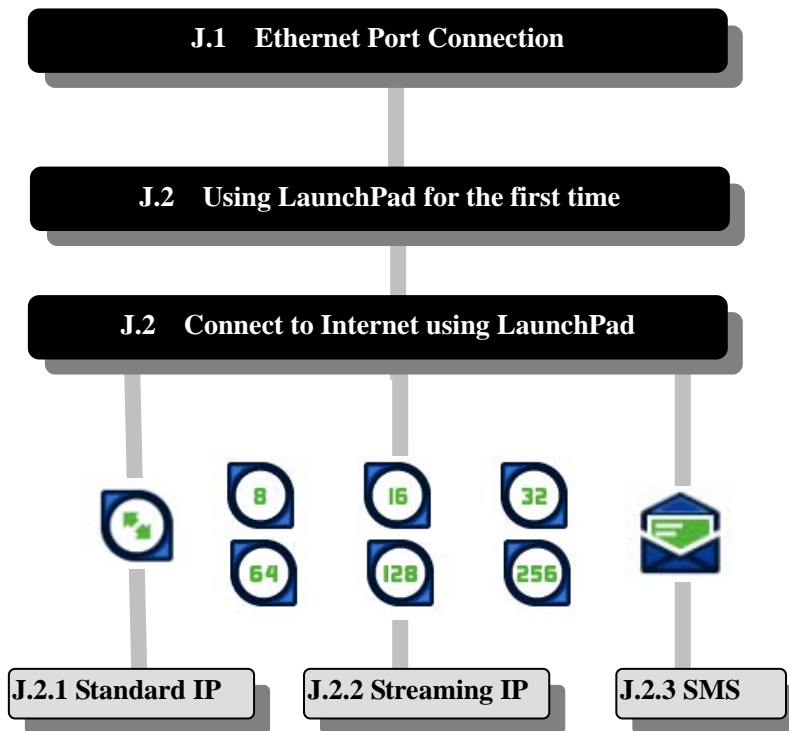

Fig.Ja Flow of [Connecting to Internet using LaunchPad]

In this Chapter, Windows XP is supposed to be used.

J.1 Ethernet Port Connection

The JUE-501/JUE-251 provides the DHCP server function, which allocates necessary IP address to the PC connected by Ethernet, to make Ethernet communication with Main Unit possible.

User is requested to setup [Obtain an IP automatically] and [Obtain DNS server address automatically] on the PC, to make use of the function.

For details, refer to [Sec.6.1 Connect Your PC to JUE-501/JUE-251].

J.2 Using LaunchPad for the first time

Setting for terminal is required for using LaunchPad for the first time.

1. Start LaunchPad by double-clicking LaunchPad icon.
2. Dialog below will be popped-up.

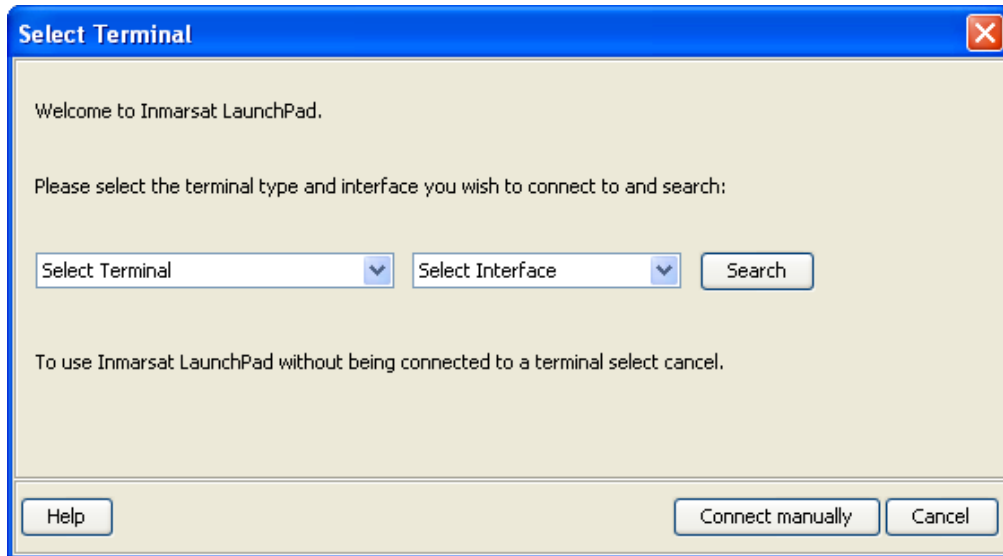

3. Select your terminal and click [Connect manually] button.

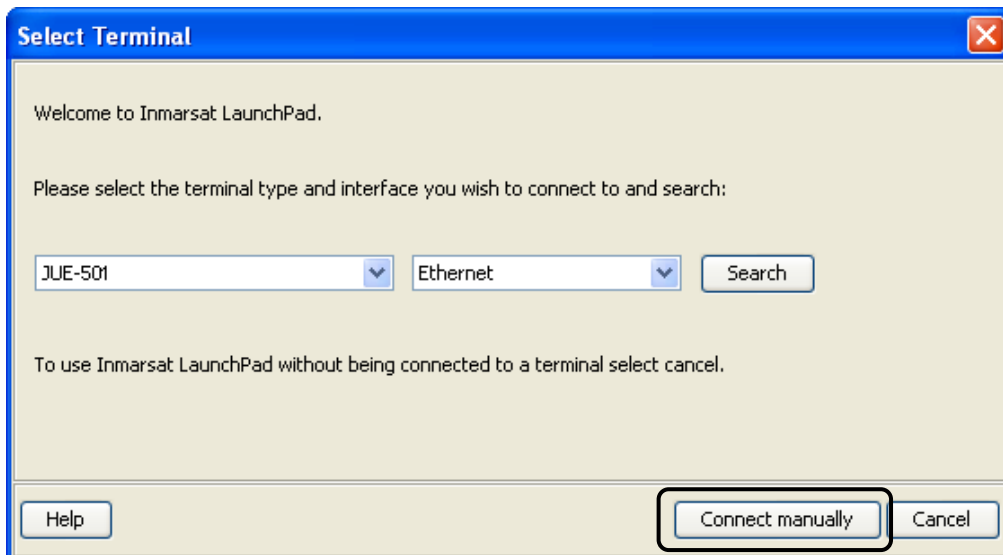

4. A dialog box of Manual Connection appears.

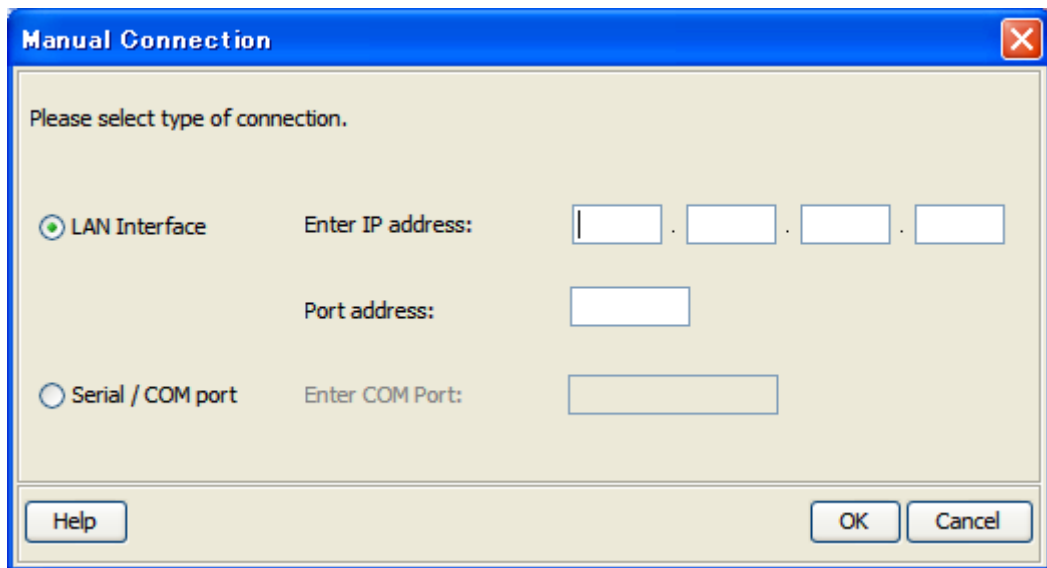

5. Enter IP address of JUE-501/JUE-251 and Port number. Then, click [OK] button.

The initial IP address is 168.128.100 and the LaunchPad uses TCP1829 port.

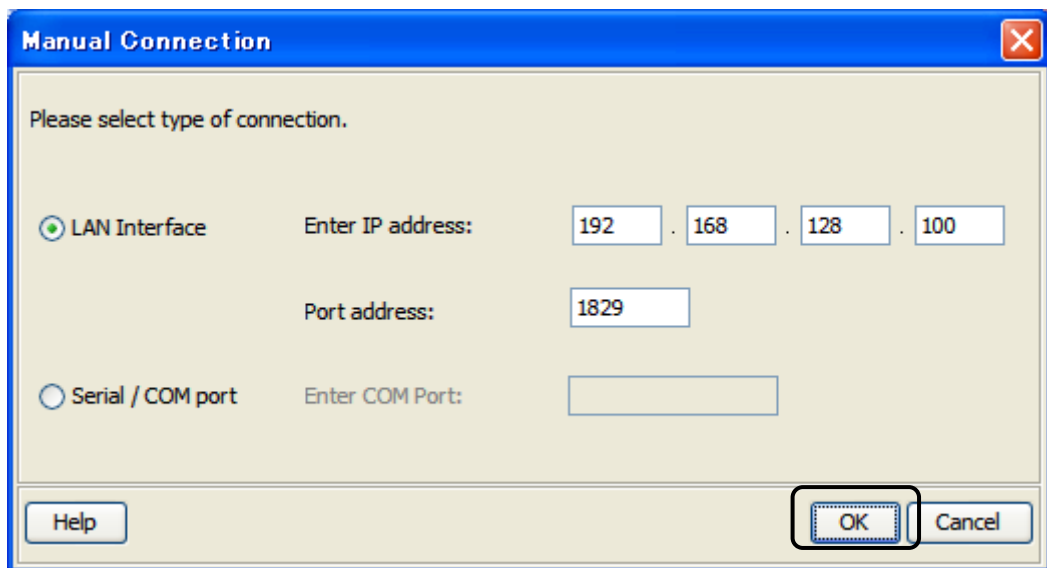

J.3 Connect to Internet using LaunchPad

By using LaunchPad, communications with services of Standard IP, Streaming IP, or SMS can be used very easily and quickly. Installation of LaunchPad is preliminarily required for this chapter, set the attached CD into your PC and install it.

J.3.1 Standard IP

Standard IP Connection/Disconnecting procedures are mentioned below.

[Connection]

1. Open LaunchPad by double clicking on the LaunchPad-short cut icon on your desktop, and then click [Data] icon.

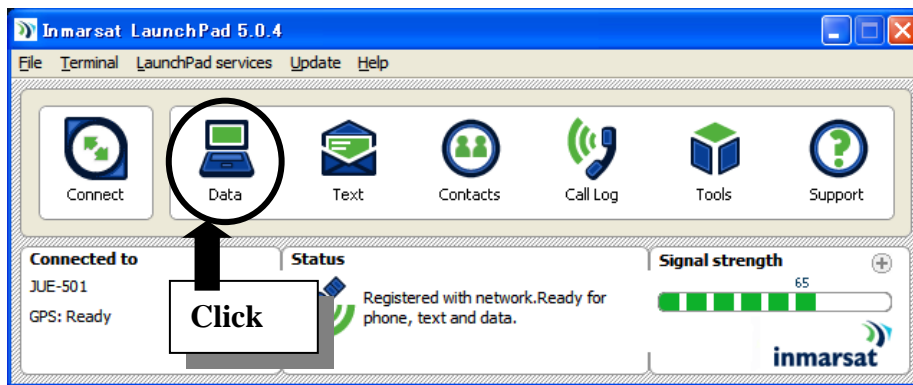

Fig.J.3.1a Main window of LaunchPad

2. Below screen is displayed. Click [Connect Standard] icon, and then connection to Standard IP service is started.

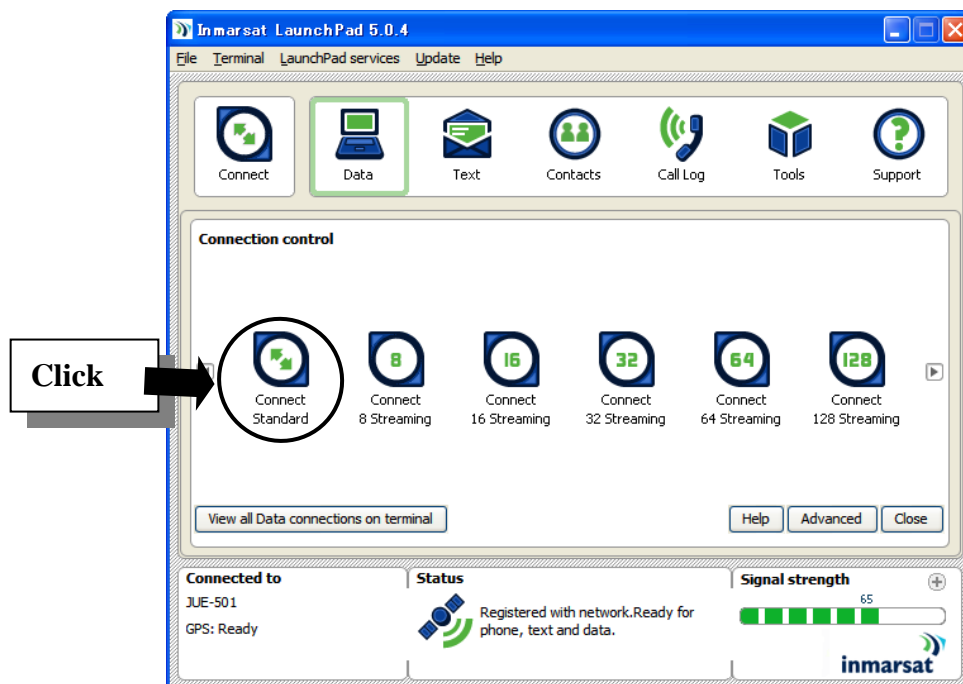

Fig.J.3.1b [Connection control] window

[Connecting] screen is displayed during Standard IP Data connection is requesting.



Fig.J.3.1c [Connecting] window

3. If connection is succeeded, [Connect] icon is changed to [Disconnect], [Connect Standard] icon is changed to [Disconnect Standard], and text of [Status] column is changed to [Standard Data connection open...].

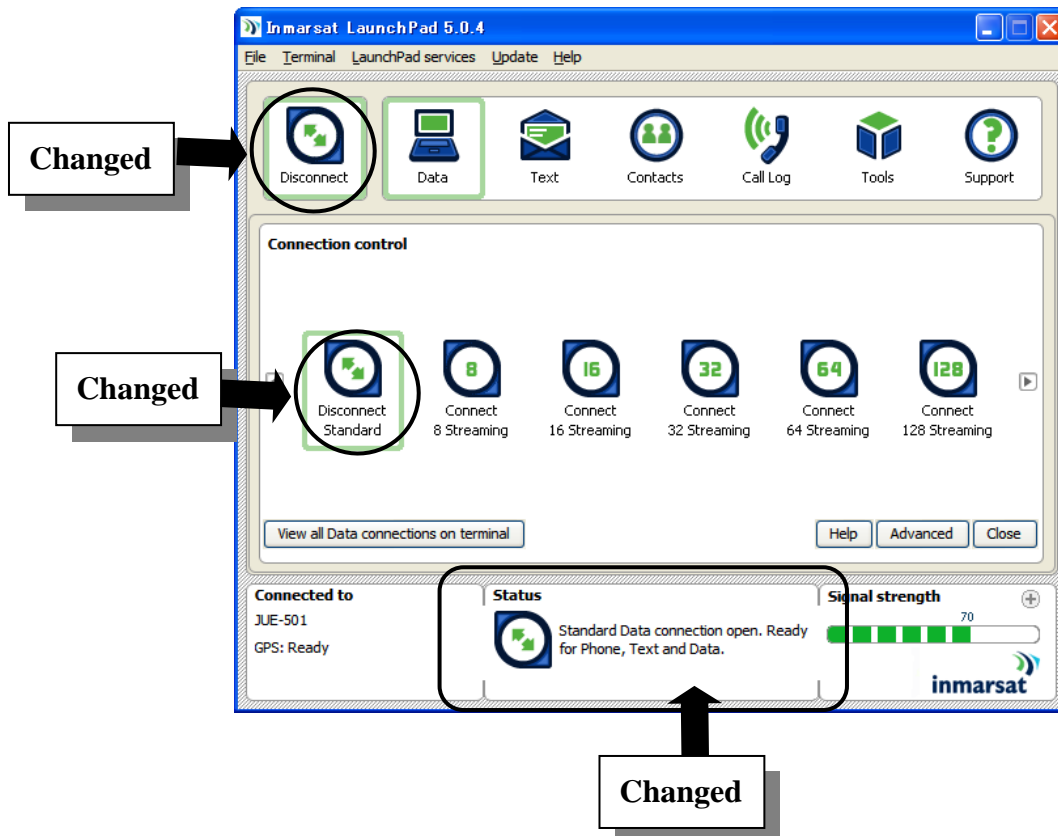

Fig.J.3.1d [Connection control] window (connection succeeded)

[Connecting to Internet]

Standard Data connection is established. Use your desirable tool.

6 PC connection and Launchpad calling

[Disconnection]

Click [Disconnect] icon.

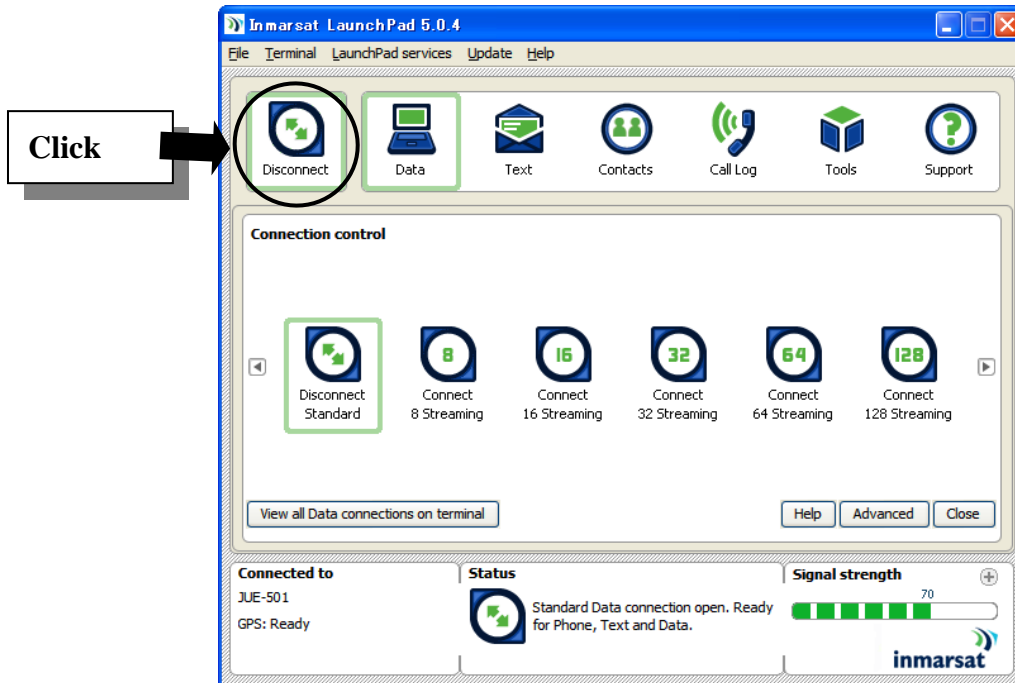

Fig.J.3.1e [Connection control] window (disconnection)

J.3.2 Streaming IP

Below procedure is for 32kbps Streaming IP service. For 8kbps, 16kbps, 64kbps, 128kbps, or 256kbps, the difference is using icons only. (256kbps Streaming IP service is available only for JUE-501.)

[Connection]

1. Open LaunchPad by double-clicking on the LaunchPad icon on your desktop, and then click [Data] icon.

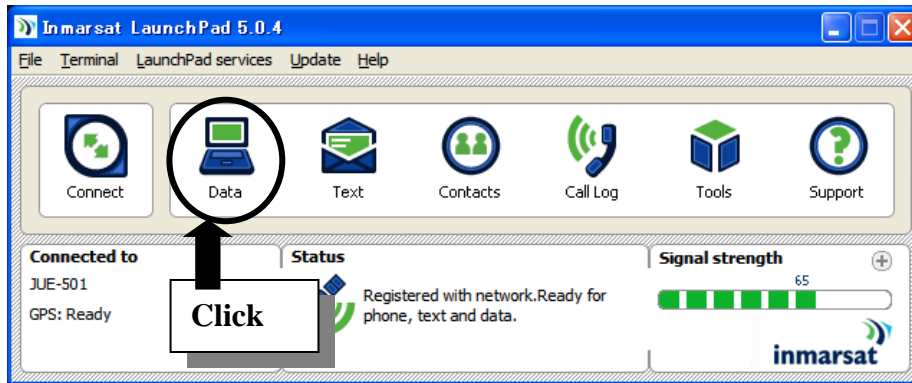

Fig.J.3.2a Main window of LaunchPad

2. Click [Connect 32 Streaming] icon, then connection to Streaming 32kbps IP service is started.

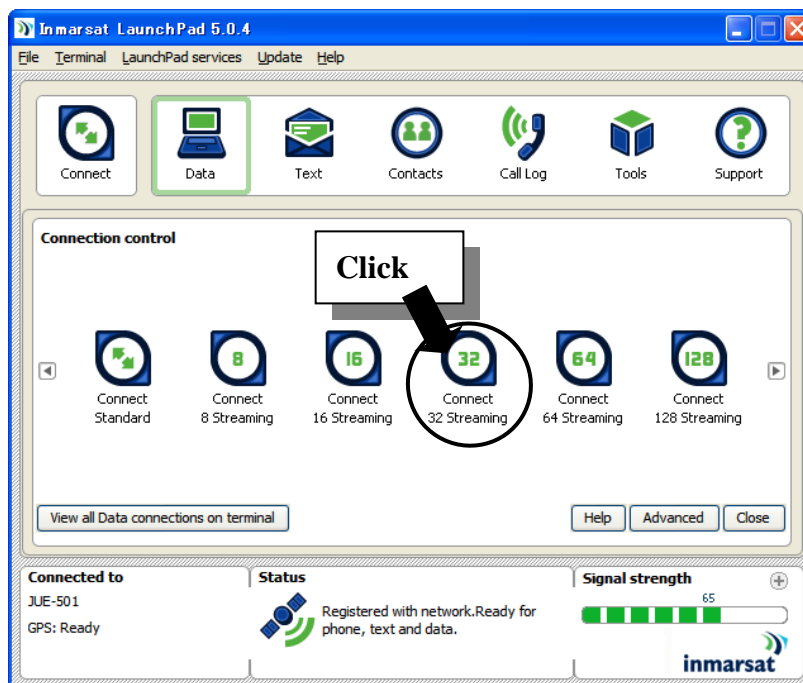

Fig.J.3.2b [Connection control] window

3. Confirmation window is displayed, then click [Yes].

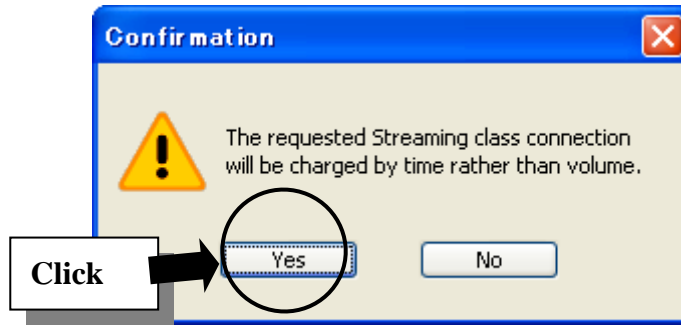

Fig.J.3.2c Confirmation window

[Connecting] screen is displayed during Streaming IP Data connection is requesting.

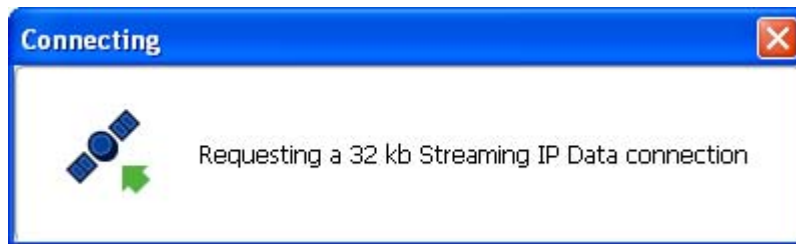

Fig.J.3.2d [Connecting] window

4. If connection is succeeded, [Connect] icon is changed to [Disconnect], [Connect 32 Streaming] icon is changed to [Disconnect 32 Streaming], and text of [Status] column is changed to [Streaming Data connection open...].

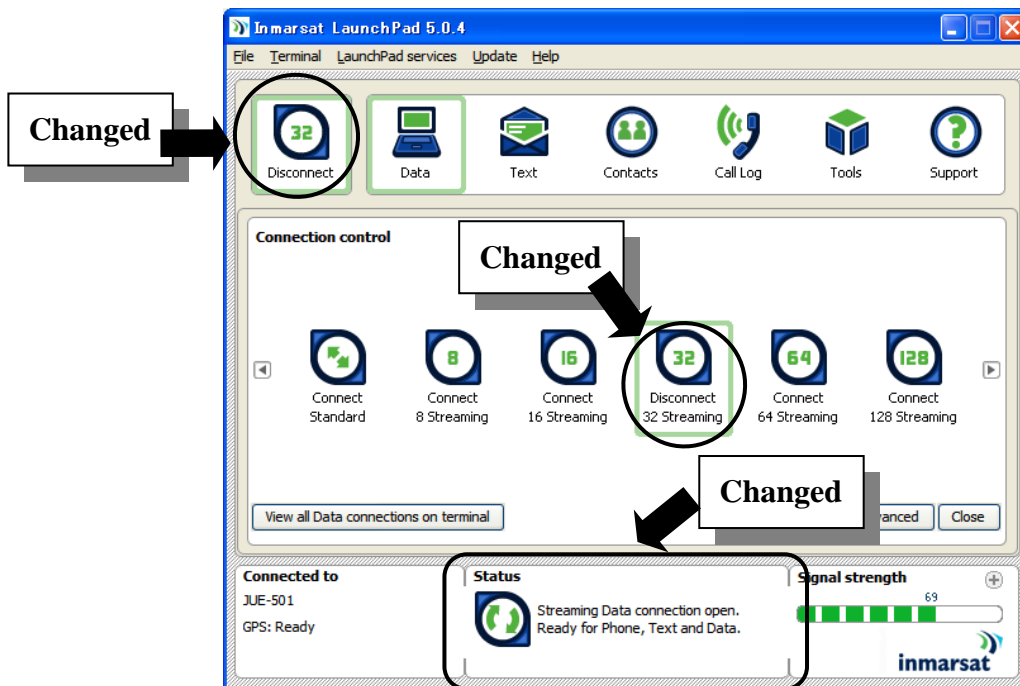

Fig.J.3.2e [Connection control] window (connection succeeded)

[Connection]

Streaming Data connection is established. Use your desirable tool.

[Disconnection]

Click [Disconnect] icon.

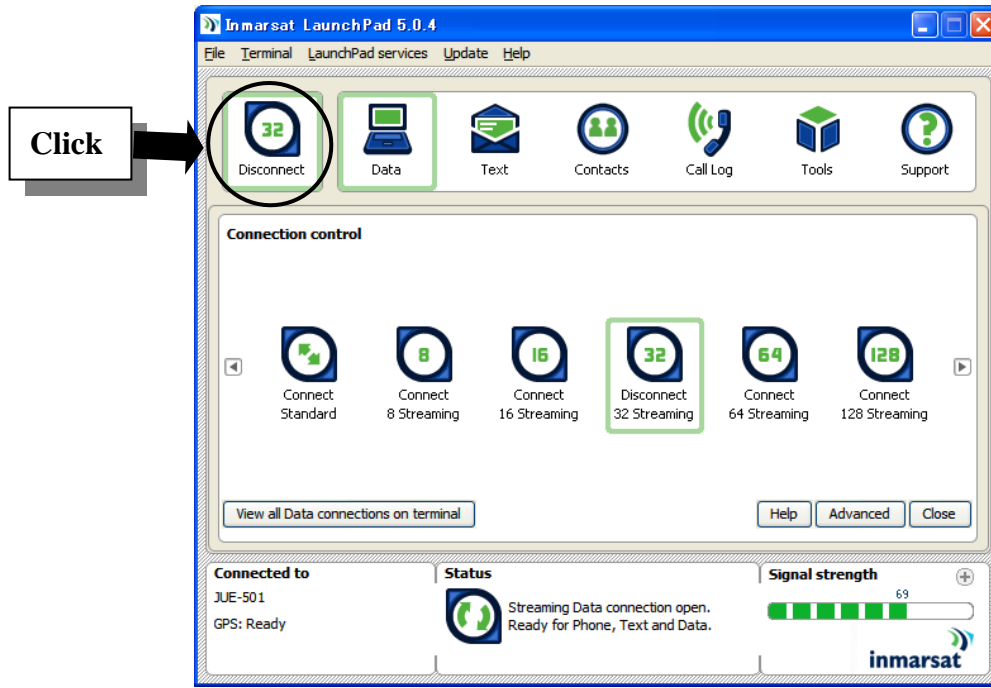

Fig.J.3.2f [Connection control] window (for disconnection)

J.2.3 SMS

Sending SMS procedures are mentioned below.

[Sending]

1. Open LaunchPad by double clicking on the LaunchPad-short cut icon on your desktop, and click [Text] button.

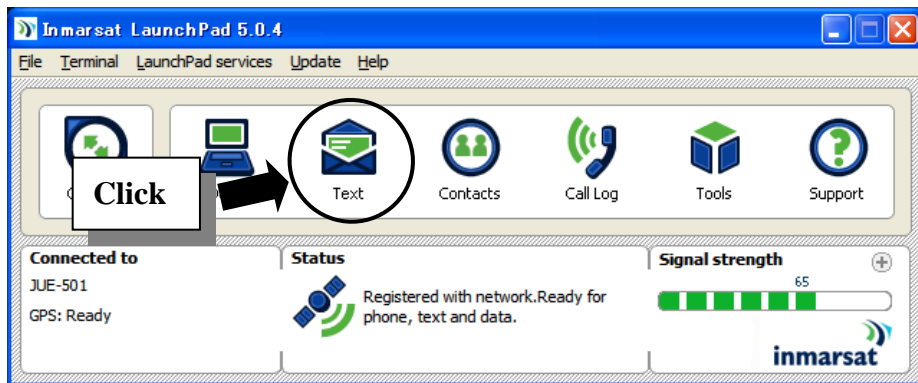

Fig.J.2.3a Main window of LaunchPad

2. Position the cursor to the large column of [Compose new message] field, and create the message. And position the cursor to [To.....] column and enter the destination number. Finally, click [Send] button.

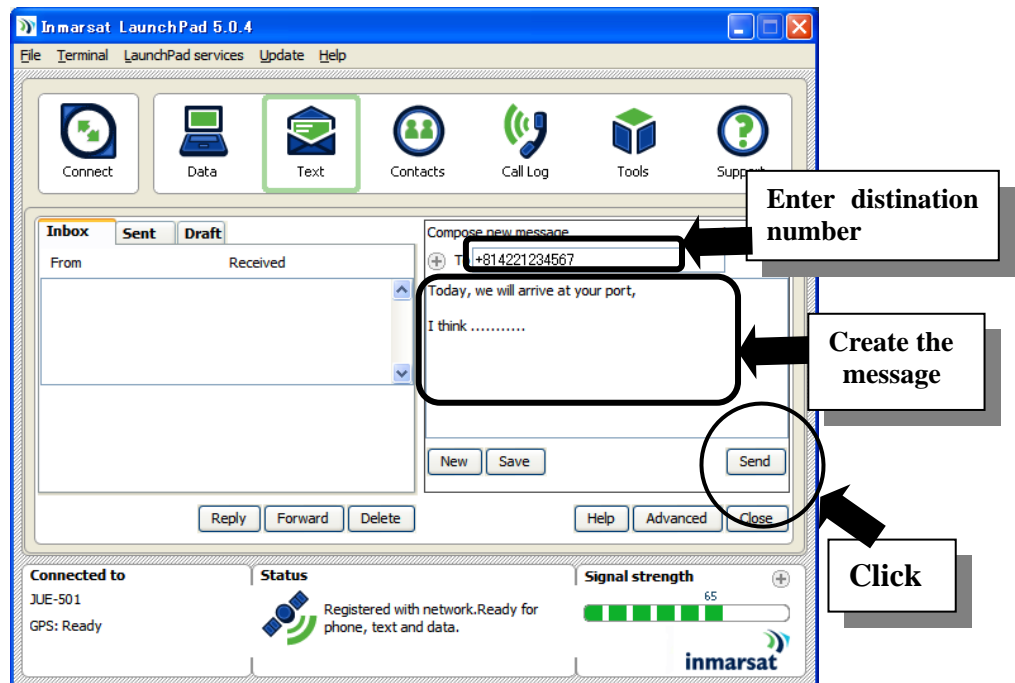

Fig.J.2.3b Text window

Appendix K TCP Accelerator Installation Procedure

K.1. About TCP Accelerator

TCP Accelerator (also known as TCP PEP) is a free software which has been tested and proven to improve the performance of TCP applications over the FleetBroadband network. TCP Accelerator boosts the upload speed of all TCP traffic by up to 300% (depending on file size), with an average increase across all applications of 40% - 80%.

TCP Accelerator is of particular benefit to activities which send short bursts of data over the network, such as Internet browsing and email.

The adjustments made by TCP Accelerator include:

- Modifying TCP window settings by changing the window size to allow a larger amount of data to be carried at any point in time over the network.
- Optimising the MTU size for the FleetBroadband network
- Negating TCP slow start behaviour, further deteriorated by the round trip time between the terminal, satellite and ground segment.

K.2. Installing and configuring TCP Accelerator

K.2.1 Minimum system requirements

The following are the mandatory hardware and software requirements for successful installation of TCP Accelerator on your computer:

Hardware requirements

- Intel Pentium IV, or equivalent.
- 256 MB RAM.
- 20 MB hard disc space.

Software requirements

- Windows XP/Vista/7 32bit installed on your computer.
- NOTE: Windows XP/Vista/7 64bit is not supported

K.2.2 Installing TCP Accelerator

1. Unzip SetupXP-Rxx.x-xxx.zip or SetupVista-Rxx.x-xxx.zip in the CD-ROM, and execute .exe file in unzipped file. The Setup Wizard launches automatically, and the following screen is displayed:



2. Click on Next. The “Welcome to the InstallShield Wizard for TCP PEP” screen is displayed, as shown below:



3. Click on Next. The “Terms and Conditions” screen is displayed, as shown below:

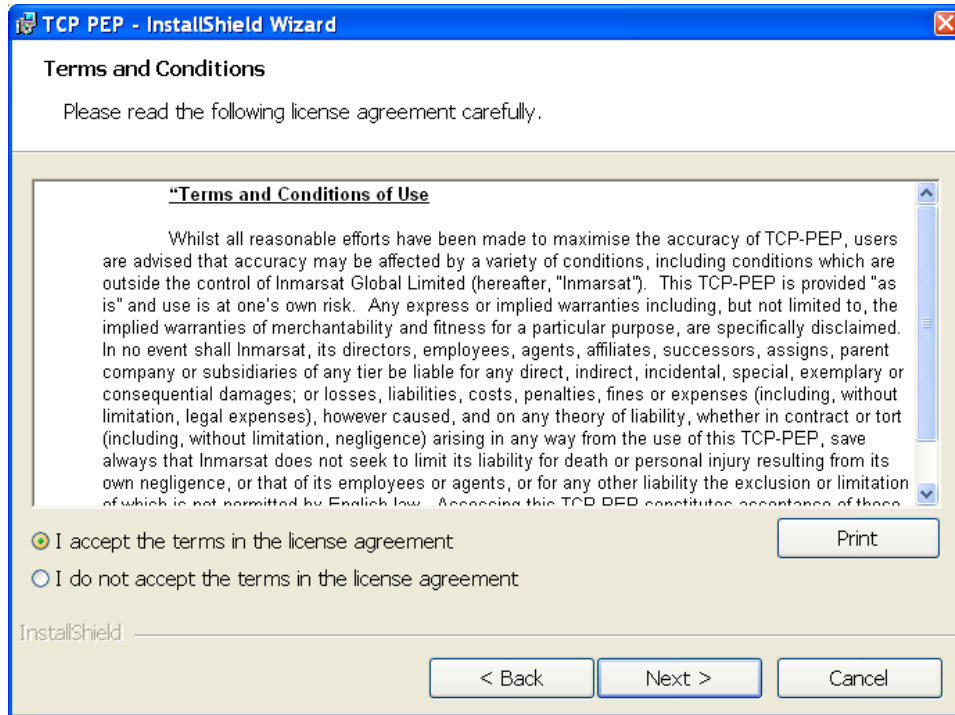

4. Select the “I accept the terms in the license agreement” radio button, and click Next. The Destination Folder screen is displayed, as shown below:

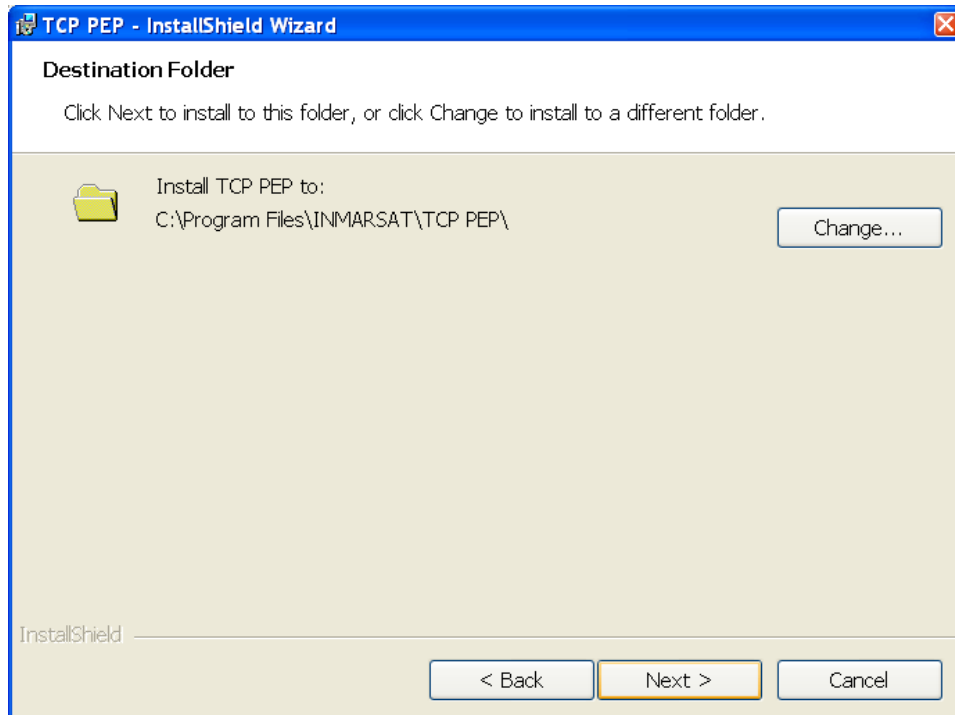

5. If you want the program files to be installed in the default directory, click on Next. To select a different directory, click on Change..., and select the required directory, then click on Next. The "Preparing to Install" screen is displayed, as shown below, and TCP Accelerator performs pre-installation checks:

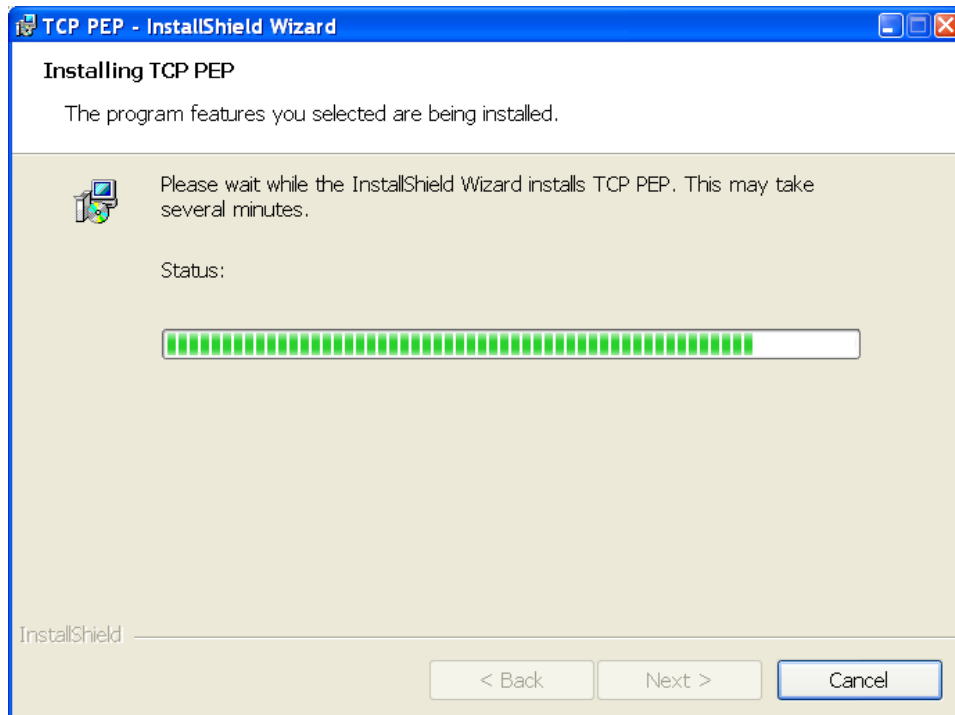

If the program detects that your computer is not fully optimized for TCP Accelerator, the following screen is displayed: If you see this screen, click on OK when prompted to reboot your computer. This is a one time optimization, and is not repeated for subsequent TCP Accelerator releases. After rebooting your computer, do from step 1 again.

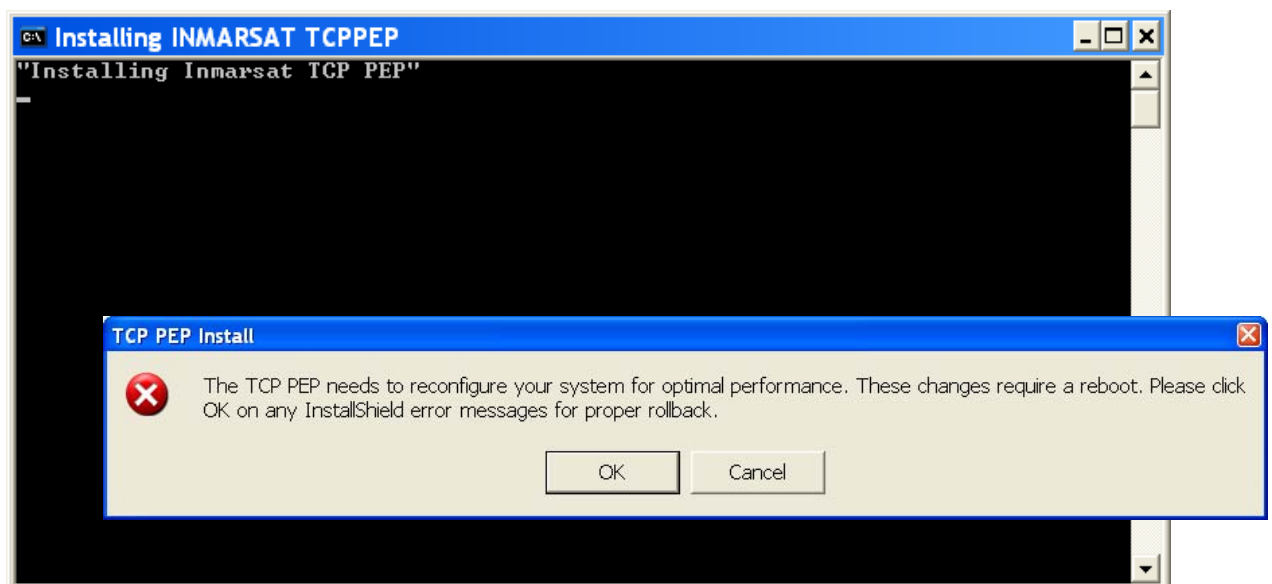

If the program fails Windows Logo testing, the following screen is displayed: If you see this screen, click on Continue Anyway. Note that you may see this screen more than once: click on Continue Anyway each time. (This screen displays if the driver is yet to formally complete the certification procedure for Windows.)

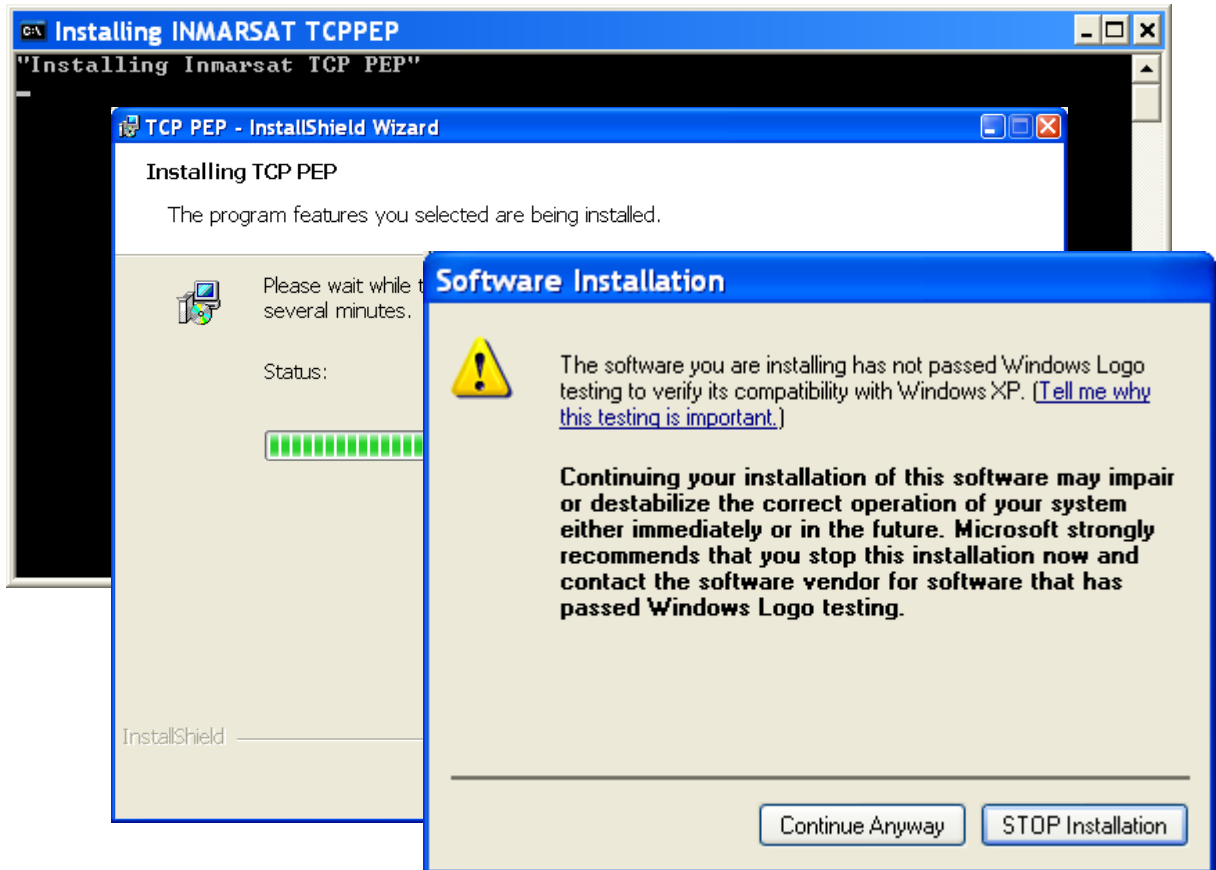

6. When the installation is complete, the following screen is displayed:

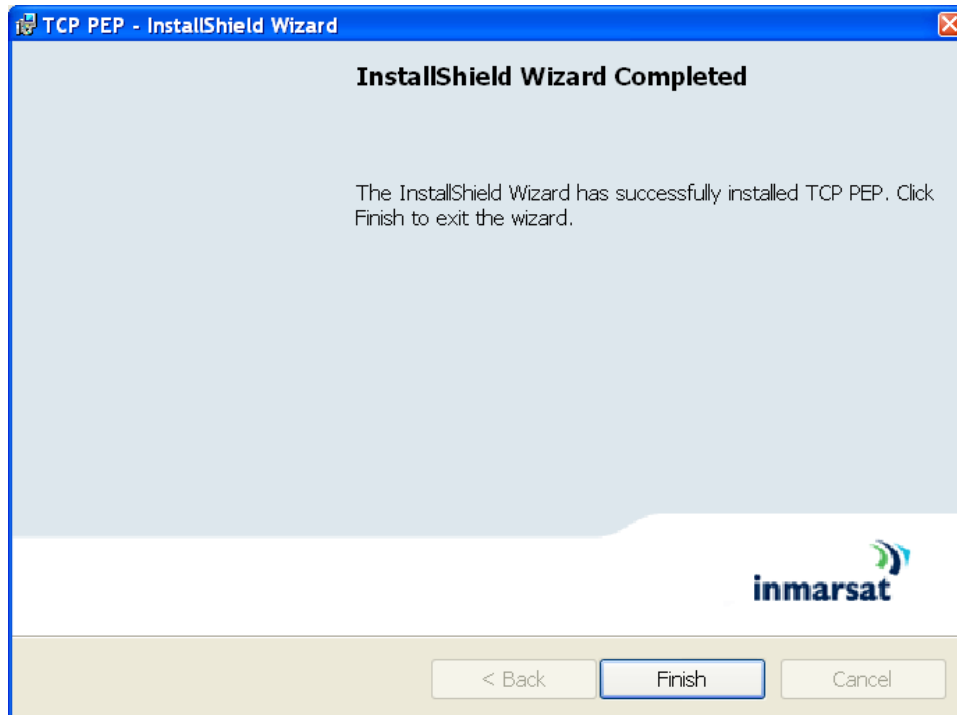

7. Click on Finish to complete the installation. The following screen is displayed:

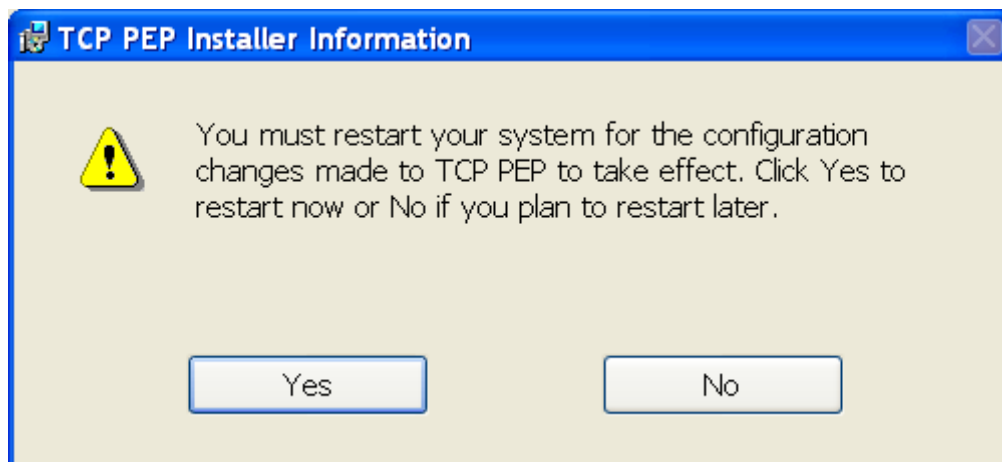

8. Click on Yes to restart the computer.

Appendix L Trouble shooting and FAQ

When a fault has been detected, operate according to the FAQ. If it is not improved, turn OFF and ON the power switch of main unit to reboot. Rebooting the main unit doesn't delete your settings and data. Still it persists, stop operation and contact the purchasing dealer.

FAQ Contents

1. Power supply, Start up	L-2
2. Reception of radio wave from a satellite	L-3
3. Web Menu System	L-4
4. LaunchPad	L-5
5. TEL	L-6
6. FAX	L-7
7. Packet Switch (Standard IP, Streaming IP) service	L-8
8.SMS	L-9
9.ISDN	L-10
10.Actions to be taken when abnormal status is indicated on Handset	L-11
11.When the call log sort function is not working	L-14
12.Other problems	

L.L. Power supply, Start up		
Problem (P)	Possible cause	Confirmation item
BDE does not start up	The circuit breaker is thrown.	Turn the circuit breaker on.
	External power is not supplied.	Turn the external power on.
	Fuse is blown.	Pick up the fuse from the fuse box and make sure if the fuse is blown. When the fuse is blown, please replace the fuse with a spare.
	If the problem is not solved with above countermeasures, disconnect external power, and please contact the dealer you purchased JUE-501/JUE-251 from.	

L.2. Reception of radio wave from a satellite

Problem (P)	Possible cause	Confirmation item
<p>[Not Ready] is displayed and communication is impossible.</p>	<p>Satellite is not selected correctly.</p> <p>Blocking.</p> <p>Out of satellite cover area</p> <p>If the problem is not solved with above countermeasures, turn OFF and ON the power source of main unit to reboot JUE-501/JUE-251.</p>	<p>Select the correct satellite at [Satellite] menu.</p> <p>Check if there is obstruction between the antenna and the satellite.</p> <p>Select another satellite when there is an obstacle, to turn the antenna to the clear view direction. Or wait until the ship changes her course.</p> <p>*If the Blocking Area has been set correctly in [Terminal] menu, the antenna icon on Handset screen starts blinking and that on Web menu screen changes into orange color.</p> <p>Check your ship is existing inner the cover area of satellite or not.</p> <p>If your ship is out of the cover area, use JUE-501/JUE-251 after your ship has entered into the cover area of the satellite.</p>
<p>Received signal strength is weak.</p>	<p>Blocking</p>	<p>Execute Satellite Search (selecting the satellite again). Also, check if there is obstruction between the antenna and the satellite.</p> <p>Select another satellite when there is an obstacle, to turn the antenna to the clear view direction. Or wait until the ship changes her course.</p> <p>*If the Blocking Area has been set correctly in [Terminal] menu, the antenna icon on Handset screen starts blinking and that on Web menu screen changes into orange color.</p>

L.3. Web Menu System

Problem (P)	Possible cause	Confirmation item
<p>[Terminal] screen can not be displayed when the IP address of main unit was entered to the URL box on Web browser.</p>	<p>Cable is not connected.</p> <p>Although the setting of the TCP/IP of the PC is set to “Automatic access”, the PC could not access the IP from the DHCP server.</p> <p>TCP/IP is not set.</p> <p>URL is not correct.</p> <p>The local area connection of the PC is disabled. (Win2000 or later)</p> <p>The local area connection of the PC is a bridge connection.</p> <p>The version of Web browser is not supported.</p>	<p>Check that PC is connected to the main unit with Ethernet cable firmly. If there is a link between the main unit and PC, the Link LED of the Ether port on back panel will blink.</p> <p>Before starting the PC, check that the cable between the main unit and the PC is connected correctly. If the PC has been started not connected to the main unit, restart the PC after hooking up the main unit.</p> <p>Check that the network IP, subnet mask and default gateway that are set in the PC match those set in the main unit.</p> <p>*If you have set VLANs, each “User LAN Port” may have different network.</p> <p>Check that the IP address entered in URL box is that of main unit.</p> <p>*If you have set VLANs, each “User LAN Port” may have different network.</p> <p>Check that the local area connection is set to ‘enable’ in the property specification of the local area connection.</p> <p>Delete the bridge by clicking the right mouse button on the icon of the local area connection.</p> <p>JUE-501 / JUE-251 officially supports Microsoft Internet Explorer7 and Mozilla Firefox3.6, their upper version can be available when they have compatible system.</p>
<p>Error page is displayed when a button was clicked on Web menu screen.</p>	<p>The version of Web browser is not supported.</p>	<p>JUE-501 / JUE-251 officially supports Microsoft Internet Explorer7 and Mozilla Firefox3.6, their upper version can be available when they have compatible system.</p>

L.4. LaunchPad		
Problem (P)	Possible cause	Confirmation item
<p>[Select Terminal] screen is displayed after starting LaunchPad and cannot connect with main unit of JUE-501/JUE-251.</p>	<p>Cable is not connected.</p>	<p>Check that PC is connected to the main unit with Ethernet cable firmly.</p>
	<p>Although the setting of the TCP/IP of the PC is set to “Automatic access”, the PC could not access the IP from the DHCP server.</p>	<p>Before starting the PC, check that the cable between the main unit and the PC is connected correctly. If the PC has been started not connected to the main unit, restart the PC after hooking up the main unit.</p>
	<p>TCP/IP is not set.</p>	<p>Check that the network IP that is set in the PC matches the IP set in the main unit.</p>
<p>[CIF_0010] error is generated on the LaunchPad and the connection between the LaunchPad and main unit is lost.</p>	<p>The local area connection of the PC is disabled. (Win2000 or later)</p>	<p>Verify that the subnet mask, default gateway, and priority DNS server that are set in the PC match those set in the main unit.</p>
	<p>The local area connection of the PC is a bridge connection.</p>	<p>Check that the local area connection is set to ‘enable’ in the property specification of the local area connection.</p>
	<p>Ethernet connection is abnormal</p>	<p>Delete the bridge by clicking the right mouse button on the icon of the local area connection.</p>
<p>Ethernet connection is abnormal</p>		<p>Execute [Search for terminal] by LaunchPad and connect with main unit again.</p>

L.5. TEL		
Problem (P)	Possible cause	Confirmation item
Communication is impossible	Cable is not connected.	Check that the main unit or JB and the communication terminal are connected correctly. Check also that the power is supplied.
	Since a secret code type of originating call is set, input of a secret code is necessary.	Check the setting of Secret Code on the [Telephony] screen. When secret code is set to "Enable", originate a call referring to this Instruction manual.
	Communication is occupied by another port.	Check that communication is not being carried out by another TEL port or ISDN port. Check also that the telephone set is properly on-hooked.
	The # button is not pressed following the destination number.	When originating a call using a TEL port, press the # button following the destination dial number.
	If the problem is not solved with above countermeasures, turn OFF and ON the power source of main unit to reboot JUE-501/JUE-251.	
Communication is impossible with specific destination.	System failure	Ask your service provider.
Speed Dial calling and Redial calling is impossible.	Dialing sequence is incorrect.	Speed Dial calling : Speed dial number (2 digits or 3 digits) *# Redial calling : 00*#
The line can not be disconnected by on-hook	Turn OFF and ON the power switch of main unit to reboot.	

L.6. FAX		
Problem (P)	Possible cause	Confirmation item
Communication is impossible.	Cable is not connected.	Check that the main unit or JB and the communication terminal are connected correctly. Check also that the power is supplied.
	Since a secret code type of originating call is set, input of a secret code is necessary.	Check the setting of Secret Code on the [Telephony] screen. When secret code is set to "Enable", originate a call referring to this Instruction manual.
	Communication is occupied by another port.	Check that communication is not being carried out by another TEL port or ISDN port. Check also that the telephone set is properly on-hooked.
	The # button is not pressed following the destination number.	When originating a call using a TEL port, press the # button following the destination dial number.
	Service setting is incorrect.	Check that the service type is set to FAX or Audio on [Telephony] screen.
	Fax is out of service (for JUE-251).	Fax service is available for JUE-251 when the antenna EL >20 degrees.
Communication is impossible with specific destination.	If the problem is not solved with above countermeasures, turn OFF and ON the power source of main unit to reboot JUE-501/JUE-251.	
	System failure	Ask your service provider.
The line can not be disconnected by on-hook	Turn OFF and ON the power switch of main unit to reboot.	

L.7. Packet Switch(Standard IP, Streaming IP) service

Problem (P)	Possible cause	Confirmation item
Standard IP transfer rate is slow in the communication	TCP/IP application might be a cause.	Install the TCP accelerator (TCP PEP) in the attached JUE-501/JUE-251 CD-ROM, and try it. Transfer rate may be improved. However, depends on the application which has been used, the transfer rate may be downgraded.
Communication is impossible.	The line is busy.	Retry after several minutes.
	Out of the service area	256Kbps Streaming can be utilized in the area which elevation angle is 10 degrees or upper, for JUE-501 only. Also, the maximum level of Streaming service which can be utilized with Voice or FAX in the same time, is 128kbps in the area where elevation angle is 10 degrees or upper, and 64kbps in the other areas.
	If the problem is not solved with above countermeasures, turn OFF and ON the power source of main unit to reboot JUE-501/JUE-251.	
The line can not be disconnected by on-hook	Turn OFF and ON the power switch of main unit to reboot	

L.8. SMS		
Problem (P)	Possible cause	Confirmation item
Message cannot be delivered to destination.	Incorrect number is dialed.	Check the correct destination number.
Message cannot be delivered to specific destination.	System failure	Ask your service provider.
Message cannot be received.	Incorrect number is dialed.	Check that the destination terminal (land side) dialed correct number or not.
	Reception overflow	Reception is impossible when received messages exceeded the maximum number which can be saved in SIM card. Delete the received message properly.
Message cannot be received from specific destination.	System failure	Ask your service provider.

L.9. ISDN		
Problem (P)	Possible cause	Confirmation item
Communication is impossible	Cable is not connected.	Check that the main unit and the communication terminal are connected correctly. Check also that the power is supplied.
	Communication is occupied by another port.	Check that communication is not being carried out by another TEL port. Check also that the telephone set is properly on-hooked.
	The # button is not pressed following the destination number.	When originating a call using a ISDN port, press the # button following the destination dial number.
	If the problem is not solved with above countermeasures, turn OFF and ON the power source of main unit to reboot JUE-501/JUE-251.	
Communication is impossible with specific destination.	System failure	Ask your service provider.
The line can not be disconnected by on-hook.	Turn OFF and ON the power switch of main unit to reboot.	

L.10. Actions to be taken when abnormal status is indicated on Handset**Table I1. Displayed character strings and contents**

Status	Display	Contents
Abnormal	ADE? *1)	ADE abnormal.
Abnormal	POSITION? *2)	GPS dose not receive the signal from satellite.
Abnormal	SIM ? *3)	SIM is not mounted
Abnormal	SEARCH NG *4)	Searching Satellite is failed.
Abnormal	GYRO? *5)	GYRO input is abnormal.
Abnormal	HEADING ? *6)	Input of HEADING value is required

* 1) Countermeasure for ADE?

Confirm the connection of the coaxial cable.

* 2) Countermeasure for POSITION?

Built-in GPS has not fixed position information. Check the existence of blocking.

If this phenomenon is repeatedly occurred, GPS failure can be considered.

* 3) Countermeasure for SIM?

Confirm that the SIM card is correctly mounted or the card is not broken.

* 4) Countermeasure for SEARCH NG

Execute satellite search again.

* 5) Countermeasure for GYRO?

Heading information has not input from the GYRO interface although JUE-501/JUE-251 is set as GYRO tracking.

Confirm the GYRO interface or the power supply of GYRO connected to the GYRO interface is turned on.

(This abnormal status is only appeared when optional GYRO interface is connected)

* 6) Countermeasure for HEADING?

This message is displayed when entry of initial HEADING value is required with the status of [GYRO signal input setting].

Follow [Appendix C.5 Satellite menu, when JB/GYRO are used] in this manual and set exact heading azimuth for your ship. Communication on JUE-501/JUE-251 may fail due to the error of the heading value.

(This abnormal status is only appeared when optional GYRO interface is connected)

L.11. When the call log sort function is not working

When using the Internet Explorer 6, call log sort function will not work without the following Internet Explorer settings. **Please confirm the settings with network engineer.**

- 1) Select the [tool] toolbar of the Internet Explorer and select the [Internet Options...].

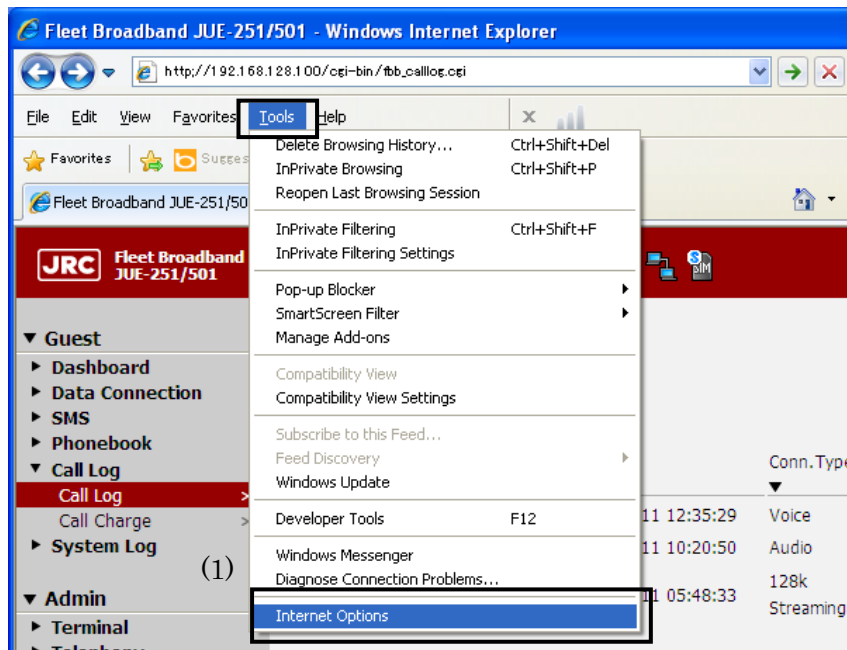

- 2) Select the [Security] tab of the [Internet Options] dialog, click [Trusted sites] icon and select the [Sites...] button.

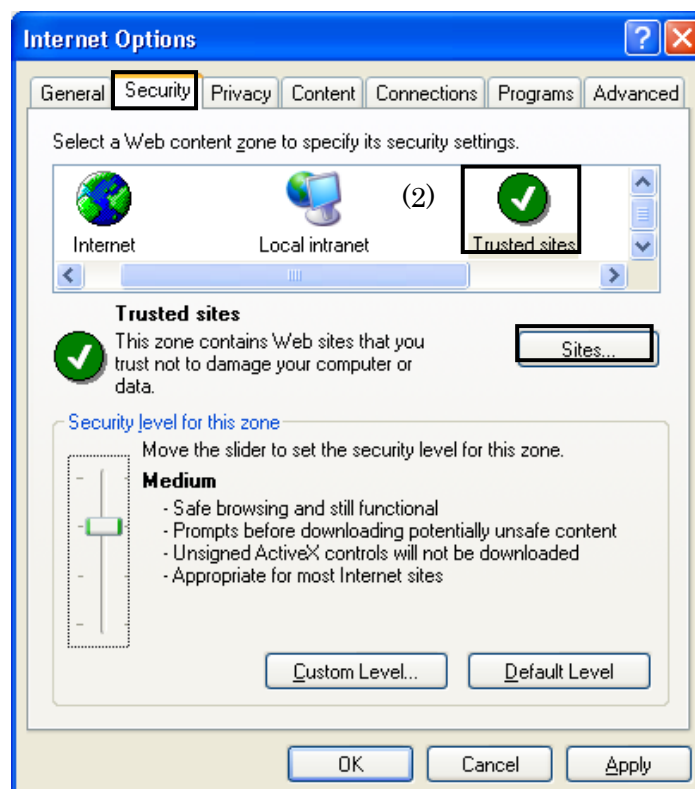

- 3) Take off a check at [Require server verification (https:) for all sites in this zone].
- 4) Add the main unit IP address (default:http://192.168.128.100/) in [Add this Web site to the zone:] test box and click [Add] button.
- 5) Confirm the main unit IP address is added to [Web sites:] textbox, click [OK] button and close the [Trusted sites] dialog.

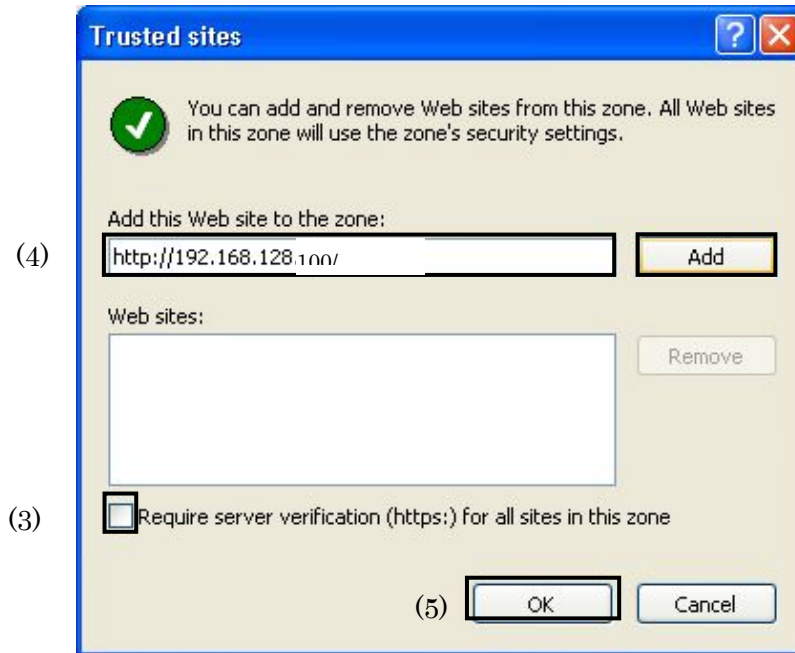

- 6) Select the [Security] tab of the [Internet Options] dialog, click [Trusted sites] icon and set [Security lever for this zone] slider lower than [High] or click [Custom Level...] enable 2 settings.

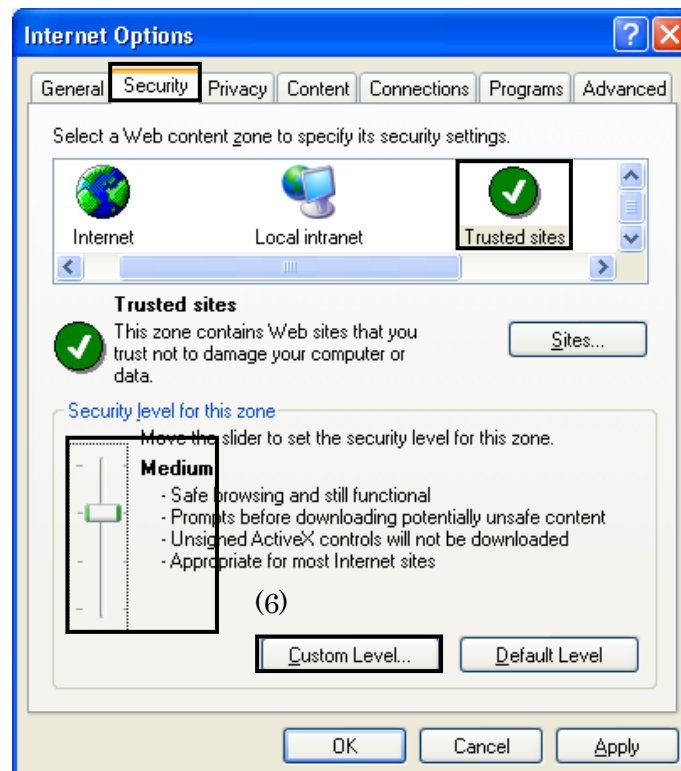

7) Change the following setting in [Security settings] dialog.

Table L2. Setting in the [Security Settings] dialog

Sections		Settings
Scripting section	Active scripting	Enable
Miscellaneous section	Lanching programs and files in an IFRAME	Enable

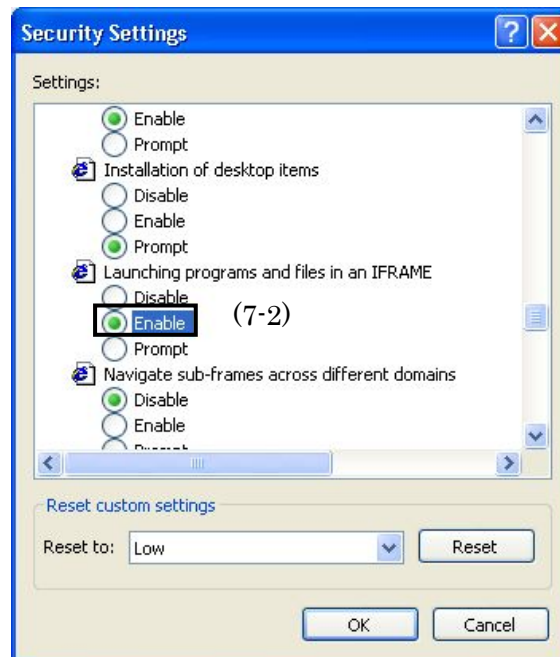
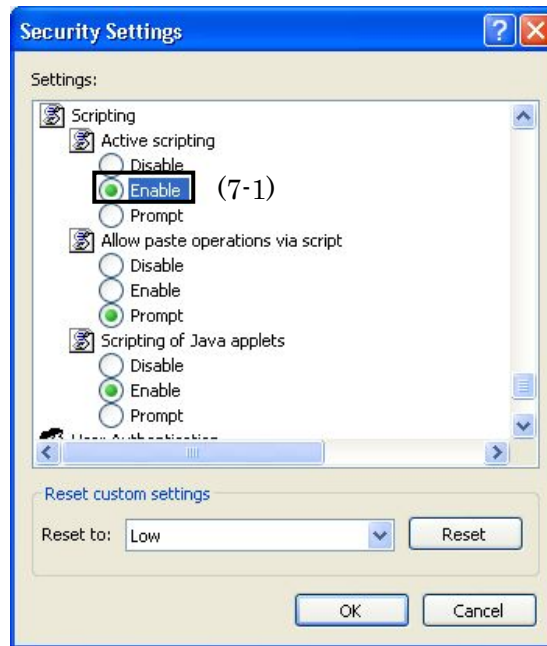

8) Click [OK] button twice and close [Security Settings] dialog and [Internet Option] dialog and finish Internet Explorer.

9) Call log sort function will work after the next start up of Internet Explorer.

L.12. Other problems

Turn OFF and ON the power switch of main unit to reboot.

This page is remained as a blank.

Appendix M Cause Code

Cause code indicates cause of disconnection of the communication.

M.1 Cause Code for CS communication (TEL, FAX)

--These Cause codes are quoted from 3GPP TS24.008 Annex H and Annex G

Normal class

No. (HEX)	Reason	No. (HEX)	Reason
0001	Unassigned (unallocated) number	0016	Number changed
0003	No route to destination	0019	Pre-emption
0006	Channel unacceptable	001A	Non-selected user clearing
0008	Operator determined barring	001B	Destination out of order
0010	Normal call clearing	001C	Invalid number format (incomplete number)
0011	User busy	001D	Facility rejected
0012	No user responding	001E	Response to STATUS ENQUIRY
0013	User alerting, no answer	001F	Normal, unspecified
0015	Call rejected		

Resource unavailable class

No. (HEX)	Reason	No. (HEX)	Reason
0022	No circuit/channel available	002B	Access information discarded
0026	Network out of order	002C	Requested circuit/channel not available
0029	Temporary failure	002F	Resource unavailable, unspecified
002A	Switching equipment congestion		

Service or option not implemented class

No. (HEX)	Reason	No. (HEX)	Reason
0031	Quality of service unavailable	0041	ACM (Accumulated Call Meter) equal to or greater than ACMmax
0032	Requested facility not subscribed	0044	Bearer service not implemented
0037	Incoming calls barred within the CUG (Closed User Group)	0045	Request facility not implemented
0039	Bearer capability not authorized	0046	Only restricted digital information bearer capability is available
003A	Bearer capability not presently available	004F	Service or option not implemented, unspecified
003F	Service or option not available, unspecified		

Invalid message (e.g., parameter out of range) class

No. (HEX)	Reason	No. (HEX)	Reason
0051	Invalid transaction identifier value	005B	Invalid transit network selection
0057	User not member of CUG(Closed User Group)	005F	Semantically incorrect message
0058	Incompatible destination		

Protocol error (e.g., unknown message) class

No. (HEX)	Reason	No. (HEX)	Reason
0060	invalid mandatory information	0064	conditional IE error
0061	message type non-existent or not implemented	0065	message not compatible with protocol state
0062	message type not compatible with protocol state	0066	recovery on timer expiry
0063	information element non-existent or not implemented	0067	protocol error, unspecified

Interworking class

No. (HEX)	Reason	No. (HEX)	Reason
007F	Interworking, unspecified		

Mobility Management

No. (HEX)	Reason	No. (HEX)	Reason
800B	PLMN not allowed	8022	Service option temporarily out of order
800C	Location area not allowed	8026	Call cannot be identified
800D	Roaming not allowed in this location area	8030-803F	Retry upon entry into a new cell
800F	No suitable cells in location area	805F	Semantically incorrect message
8011	Network failure	8060	Invalid mandatory information
8014	MAC failure	8061	Message type non-existent or not implemented
8015	Synch failure	8062	Message not compatible with protocol state
8016	Congestion	8063	Information element non-existent or implemented
8017	GSM authentication unexpected	8064	Conditional IE error
8020	Service option not supported	8065	Message not compatible with protocol state
8021	Request service option not subscribed	806F	Protocol error, unspecified.

M.2 Cause Code for PS communication*--These Cause codes are quoted from 3GPP TS24.008 Annex I***Causes related to nature of request**

No. (HEX)	Reason	No. (HEX)	Reason
0008	Operator Determined Barring	0024	Regular PDP context deactivation
0016	Congestion	0025	QoS (Quality of Service) not accepted
001A	Insufficient resources	0026	Network failure
001B	Unknown or missing access point name	0027	Reactivation requested
001C	Unknown PDP address or PDP type	0028	Feature not supported
001D	User authentication failed	0029	Semantic error in the TFT(Traffic Flow Template) operation
001E	Activation rejected by GGSN	002A	Syntactical error in the TFT operation
001F	Activation rejected unspecified	002B	Unknown PDP context
0020	Service option not supported	002C	Semantic errors in packet filter(s)
0021	Requested service option not subscribed	002D	Syntactical error in packet filter(s)
0022	Service option temporarily out of order	002E	PDP context without TFT already activated
0023	NSAPI(Network Service Access Point Identifier) already used		

Causes related to invalid messages

No. (HEX)	Reason	No. (HEX)	Reason
0051	Invalid transaction identifier value	0063	Information element non-existent or not implemented
005F	Semantically incorrect message.	0064	Conditional IE error
0060	Invalid mandatory information	0065	Message not compatible with protocol state
0061	Message type non-existent or not implemented	006F	Protocol error, unspecified
0062	Message not compatible with protocol state		

M.3 Cause code for Short Messaging Service

--These Cause codes are quoted from 3GPP TS24.011 Annex E

If the cause code is 004E, it means “Not supported of SMS cause code”.

CP-cause definition

Following cause codes are used for mobile originating short message and mobile terminating short message.

No. (HEX)	Reason	No. (HEX)	Reason
0017	Network failure	0097	Message type non-existent or not implemented
0022	Congestion	0098	Message not compatible with short message protocol state
0081	Invalid mandatory information	0099	Information element non-existent or not implemented
0095	Semantically incorrect message	0111	Protocol error, unspecified
0096	Invalid mandatory information		

RP-cause definition mobile originating SM-transfer

Following cause codes are used for only mobile originating short message.

No. (HEX)	Reason	No. (HEX)	Reason
0001	Unassigned (unallocated) number	0026	Network out of order
0008	Operator determined barring	0029	Temporary failure
000A	Call barred	002A	Congestion
0015	Short message transfer rejected	002F	Resources unavailable, unspecified
001B	Destination out of service	0032	Requested facility not subscribed
001C	Unidentified subscriber	0045	Requested facility not implemented
001D	Facility rejected	007F	Interworking, unspecified
001E	Unknown subscriber		

RP-cause definition mobile terminating SM-transfer

Following cause code is used for mobile terminating short message.

No. (HEX)	Reason	No. (HEX)	Reason
0016	Memory capacity exceeded		

M.4 Internal cause code*--These Cause codes are defined by JRC***Internal-cause definition**

Following cause codes are used for short message and PS connection.

No. (HEX)	Reason	No. (HEX)	Reason
000	No cause value	005	Timeout RelInd ignored incoming
001	Timeout RelInd	040	Shortage BPSM session
002	Timeout SetupCompleteInd	041	No CC cause value
003	Timeout SetupCnf	042	No MM cause value
004	Timeout RelInd could not answered incoming		

This page is remained as a blank.

Appendix N Front Panel LED lamps

Ready lamp: displays communication status (available/non-available)

Green light: All communication services are available.

Blinking Green: No service is available (starting system, calibrating cable, searching satellite or registering SIM).

Orange light: Registration failure or SIM card is not inserted.

Blinking Orange:

- Starting system with initialization.
- After power switch is turned off, until the power is run out completely.

Red light: System is in Safe Mode.

Blinking Red: Failure has been detected in starting system.

(No light: power switch is OFF)

ALARM lamp: indicates failure alert

Red light: Failure has occurred in the system.
(No light: The status is normal)

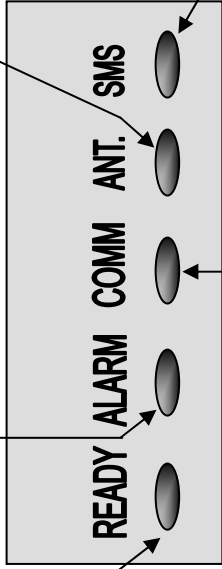

ANT. lamp: indicates the status of antenna

Green light: Tracking is being performed normally.
(Antenna is ready.)

Blinking Green: Searching satellite.

Orange light: Fail to search satellite.

Blinking Orange: Antenna has been blocked by obstruction.
(No light: power switch is OFF)

COMM lamp: indicates communication starting.

Green light: In CS service communication
(No light: In PS service communication, or no CS service communication is on the way now.)

SMS lamp: indicates receiving new SMS

Green light: New SMS has arrived.
(No light: No new SMS has arrived.)

Appendix N Front Panel LED lamps

The transition of LED panel on the front panel of the main unit is shown here.

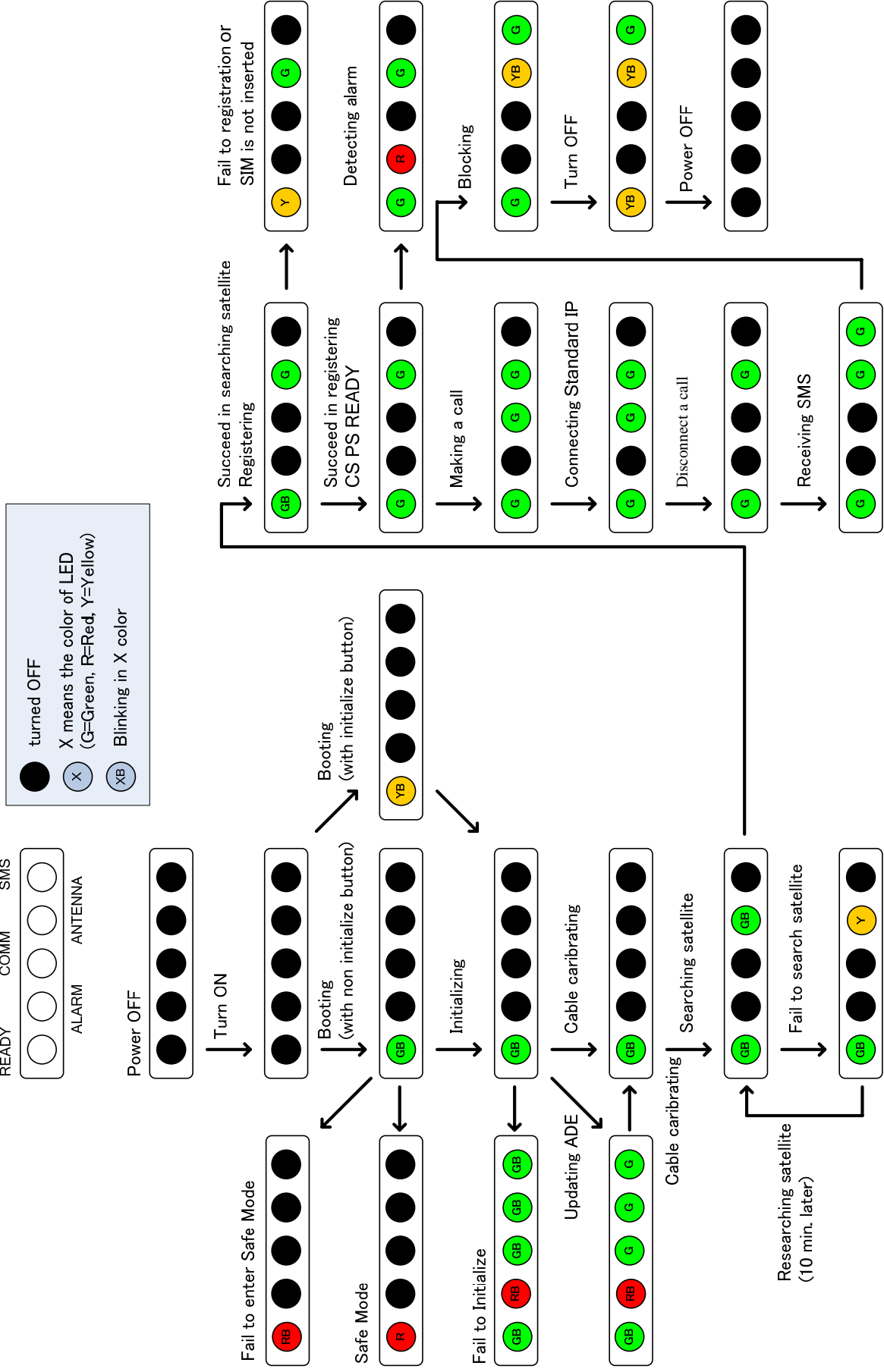

Appendix O Quick Chart

By using this quick chart, the satellite elevation and azimuth angle from the ship's position can be obtained immediately. The symbol: ● on the equator of this quick chart indicates a position of I-4 satellite.

O.1 How to obtain the SAT EL or SAT AZ angle

1. Locate the ship's position (Latitude, Longitude) on the map.
2. The intersection point of ship's position and the equal EL or AZ line obtains SAT EL or SAT AZ angle from the ship's position.

O.2 Quick chart of each ocean region

Europe, Middle East, Africa Ocean Region EMEA E25.0

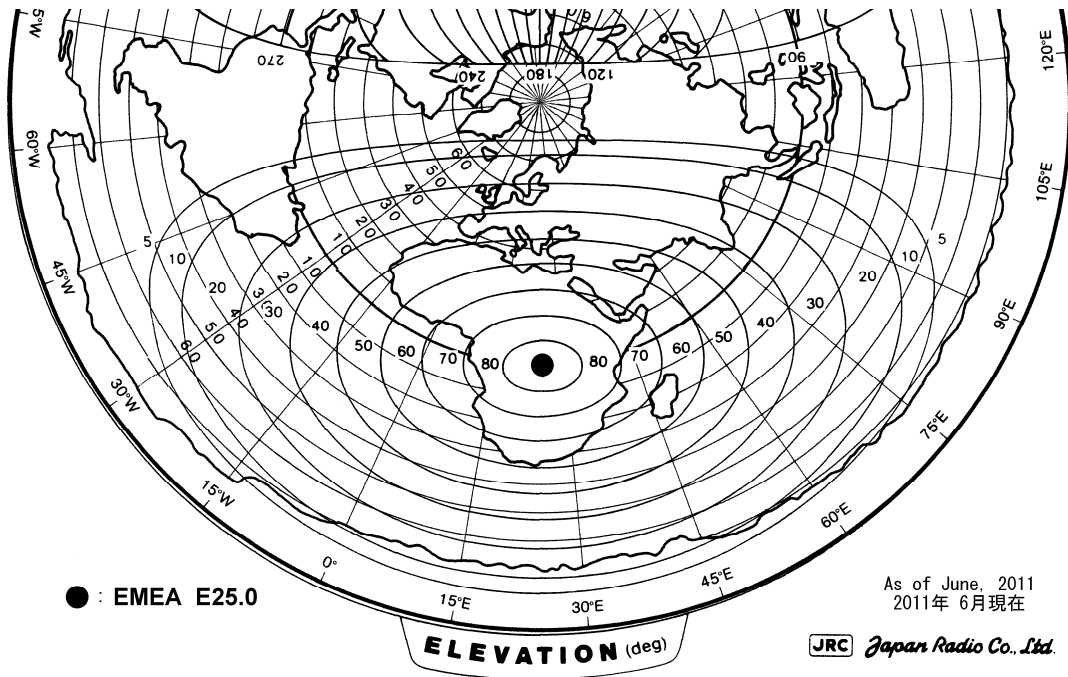

Fig.O.2.1 Equal EL line for EMEA E25.0

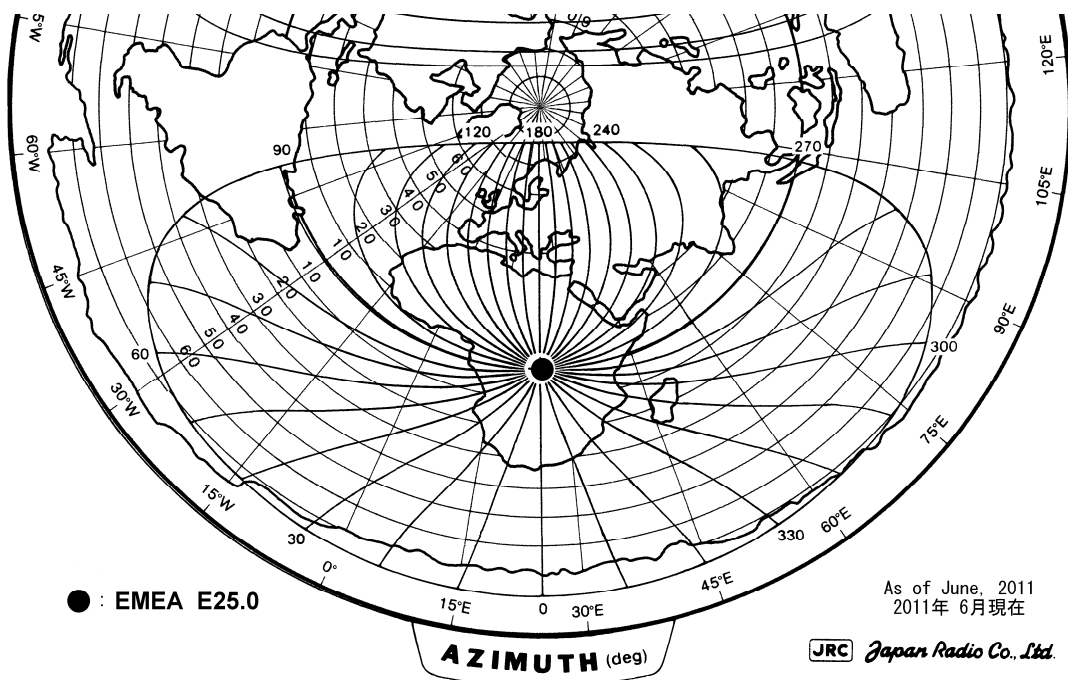

Fig.O.2.2 Equal AZ line for EMEA E25.0

Asia-Pacific Ocean Region APAC E143.5

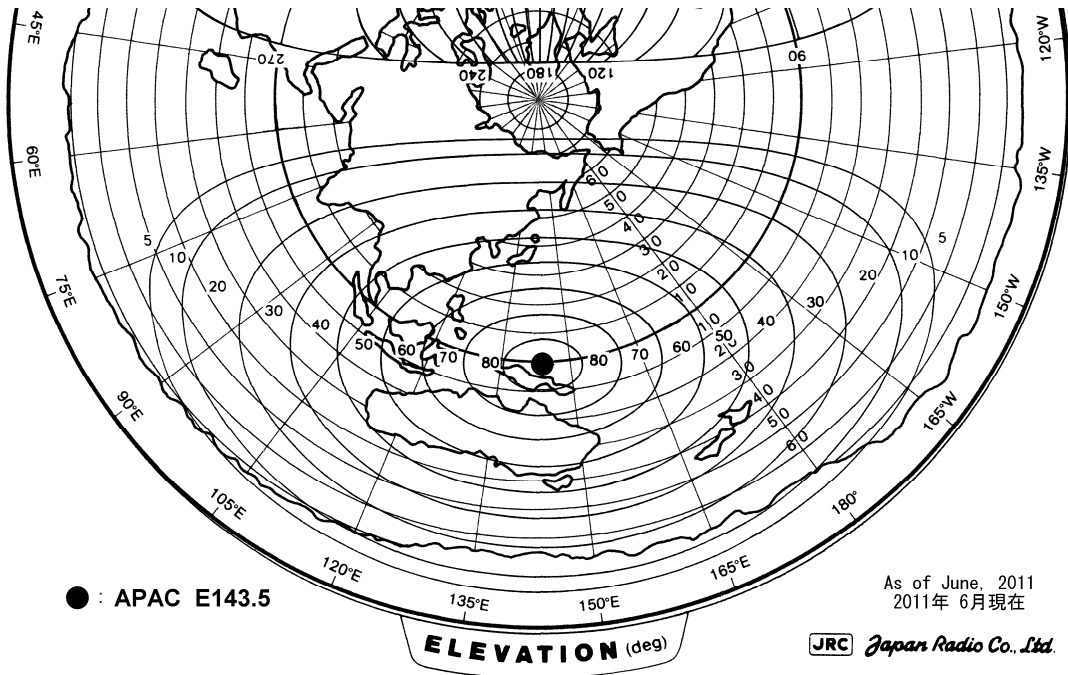

Fig.O.2.3 Equal EL line for APAC E143.5

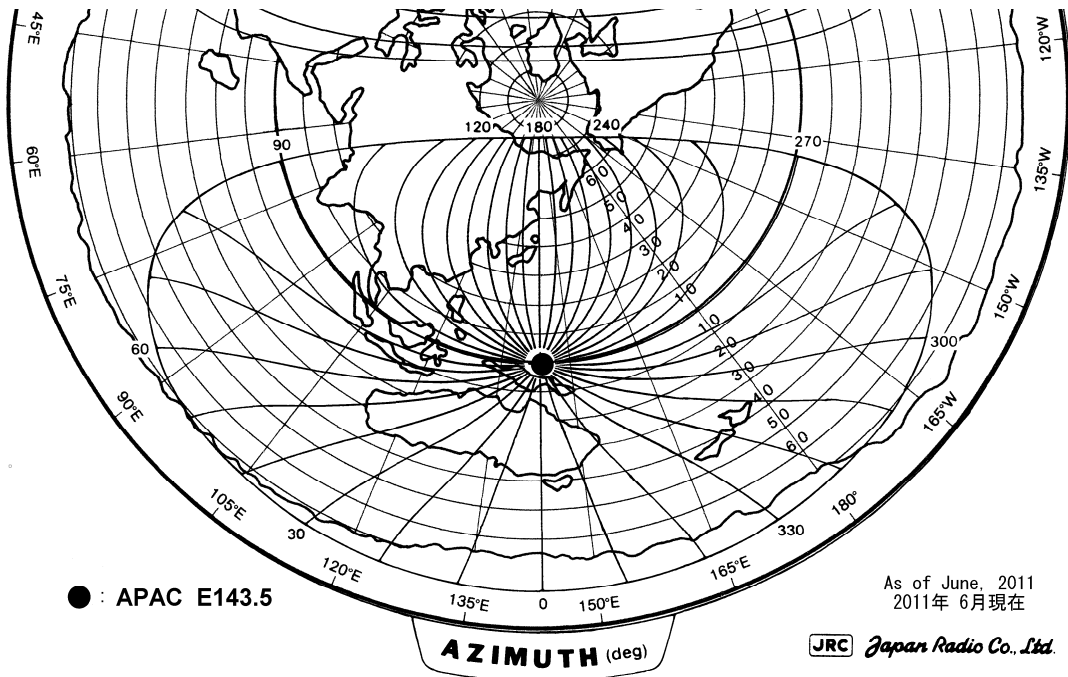

Fig.O.2.4 Equal AZ line for APAC E143.5

America Ocean Region AMER W98.0

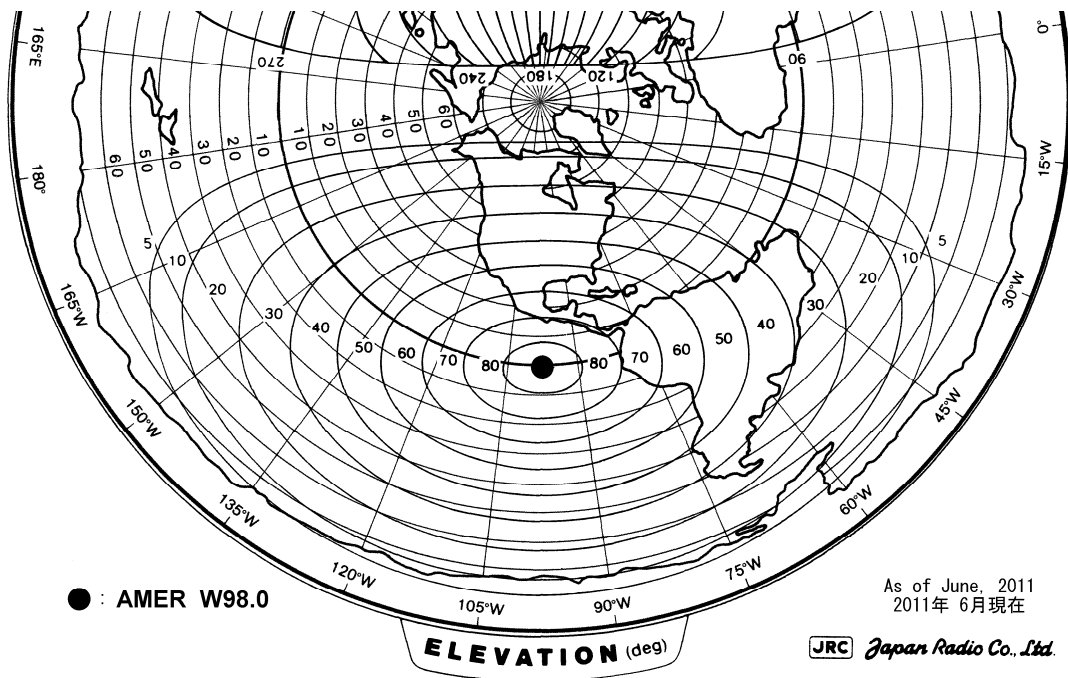

Fig.O.2.5 Equal EL line for AMER W98.0

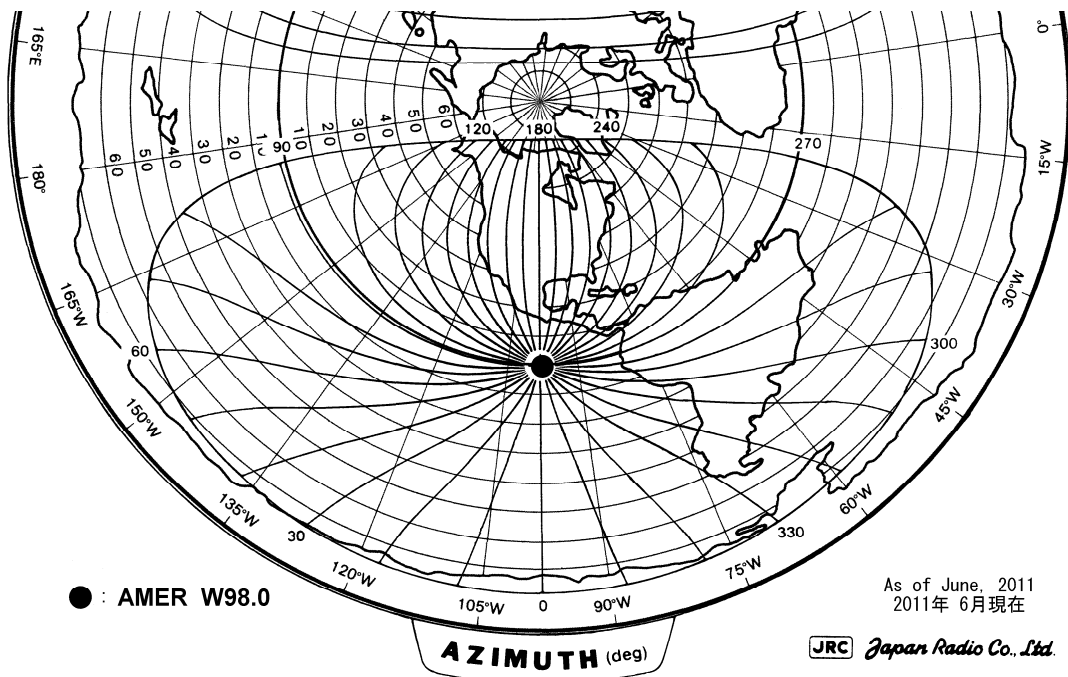

Fig.O.2.6 Equal AZ line for AMER W98.0

Appendix P Glossary

A

ADE Above Deck Equipment

AOR Atlantic Ocean Region

APN Access Point Name

ASCII American Standard Code for Information Interchange

*A standard alphanumeric character set based on 7-bit codes.

AZ Azimuth

B

BDE Below Deck Equipment

Bit The basic unit of digital communications; may be either 1 or 0.

BPS (bit per second) A unit of measurement for speed of data transfer or throughput.

BR BeARing

Bulletin Board (in a TDM channel)

*A data packet transmitted in each frame of a TDM channel which contains information about the status of the Inmarsat B/M, mini-M and C network configurations and the current frame number, used by the MES as a timing reference.

Byte *One byte comprises eight bits and may represent either one alphanumeric character or numeric information.

C

CCIR Consulting Committee of International Radio communications

CCITT Consulting Committee of International Telegraph & Telephone

Character *One element of an alphanumeric character set. One character is equivalent to one byte or 8 bits.

COMM Communication

CPU Central Processing Unit

Command *The generic name for anything you tell a computer program to do.

CS Circuit Switched

D

dB Decibel

DC Direct Current

DCN Disconnection

DEC Decoder Circuit

Appendix P Glossary

	DEL	Delete
	DEM	Demodulator Circuit
	DHCP	Dynamic Host Configuration Protocol
	DMZ	DeMilitarized Zone
	DNS	Domain Name System
	DP	Distribution Partner
	DTE	Data Terminal Equipment
E		
	EEPROM (Electrically Erasable and Programmable ROM)	
		*Read only Memory that is able to delete and rewrite electrically.
	EIA	Electronic Industries Association
	EIRP	Effective Isotropically Radiated Power
		*A measure of transmitted power.
	EL	ELevation
	EXT	External
F		
	FN	Function
G		
	GMDSS (Global Maritime Distress and Safety Service)	
		*The Global Maritime Distress and Safety System: the Inmarsat-A/B and C systems are the only Inmarsat networks included in the GMDSS by the IMO International Maritime Organization.
	GPRS	General Packet Radio Service
	GPS	Global Positioning System
		*System which provides the geographic location of a vessel. This service uses American military satellites which have been made available for civilian use.
H		
	HD	HeaDing
	HPA	High Power Amplifier
I		
	IMEI	International Mobile Equipment Identity
	IMN	Inmarsat Mobile Number
	IMO	Internally Maritime Organization
	IMSI	International Mobile Subscriber Identity number
	INFO	Information
	INMARSAT	International Maritime Satellite Organization
		*The operator of global mobile satellite communications, part of the Inmarsat

Ventures Ltd group of companies.

	I/O	Input/Output
	IOR	Indian Ocean Region
	IP	Internet Protocol
	ISDN	Integrated Services Digital Network
	ISO	International Organization for Standardization
	ITU	International Telecommunication Union
K		
	Kbytes	1024 bytes
L		
	LAN	Local Area Network
	LCD	Liquid Crystal Display
	LED	Light Emitting Diode
	LMSS	Land Mobile Satellite Service
	LNA	Low Noise Amplifier
	LT	Local Time
M		
	MAC Address	Media Access Control Address
	MDM / Modem	MODulator/DEModulator
		*A device used to transmit digital data, by converting (modulating) a digital signal into an analogue form and re-converting (demodulating) the analogue signal into digital form at the receiving end.
	MES	Mobile Earth Station
		*The generic name used to describe an Inmarsat-approved terminal which is allowed to access the network, and applicable to both maritime and land mobile communications.
	Message channel	
		*A channel assigned by the NCS for an MES to send a message through an SAS to its required destination.
	MSISDN	Mobile Subscriber ISDN
	MSN	Multiple Subscriber Number
N		
	NCS Common Signaling Channel	
		*Also known as the NCS Common Channel. A TDM channel used by the NCS to transmit system information and message announcements to MESs.
	NMEA	National Marine Electronics Association
O		
	Ocean Region	
		*The coverage area of an Inmarsat satellite within which an MES may send and receive messages.

OSC Oscillator

P

Packet

*An envelope or block of data sent over a network; each packet contains addressing information as well as the data being sent.

PBX Private Branch eXchanger

PC Personal Computer

PDP Packet Data Protocol

PIN Personal Identification Number

PoE Power over Ethernet

POR Pacific Ocean Region

PPP Point-to-Point-Protocol

PPPoE PPP over Ethernet

Protocol

*A defined set of communications standards which lay down the parameters to which all users must abide. Protocols in general use are X.25 and X.400.

PS Packet Switched

PSDN Packet Switched Data Network

PSTN Public Switched Telephone Network

PSU Power Supply Unit

PUK PIN Unblocking Key

R

RAM Random Access Memory

REC Receiving level

ROM Read Only Memory

RSSI Received Signal Strength Indicator

RX Receive/Receiver

S

SAS Satellite Access Station

SCA Service Centre Address

SDM System Definition Manual

SIM Subscriber Identity Module

SMS Short Message Service

SOLAS Safety of Life at Sea

Space segment Consists of the communications satellites operated by Inmarsat

Special access code

*A destination address code used in a ship-to-shore or shore-to-ship message to access a special service provided by a service provider. The two-digit codes are examples of special access codes.

- SYNC** Synchronization

- T**
- TDM** Time Division Multiplex
 - *The process by which multiple signals can share the same communication channel, each using a different time slot.
- TDMA** Time Division Multiple Access
 - *The process by which MESs communicate with an SAS or NCS.

- TX** Transmit/Transmitter

- U**
- USB** Universal Serial Bus
- UTC** Universal Coordinated Time
 - A term which, for practical purposes, has the same meaning as Greenwich Mean Time (GMT).

- V**
- VDB** Voice Distress Button
- VLAN** Virtual LAN
- VPN** Virtual Private Network

- W**
- WAN** Wide Area Network
- WRF** Wide-band Radio Frequency

This page is remained as a blank.

Appendix Q JRC Network

If your JUE-501/JUE-251 has problems in operation, please contact the dealer you purchased it from.
For assistance in finding a Service Center, please access one of the following web sites.

JRC web site

JRC Japan: <http://www.jrc.co.jp>
JRC Amsterdam <http://www.jrceurope.com/>
JRC Seattle: <http://www.jrcamerica.com>

电子信息产品有害物资申明
日本无线株式会社

Declaration on toxic & hazardous substances or elements
of Electronic Information Products
Japan Radio Company Limited

有毒有害物质或元素的名称及含量
(Names & Content of toxic and hazardous substances or elements)

形式名(Type): JUE-501/JUE-251

名称(Name): INMARSAT FleetBroadband FB500/FB250
Maritime Satellite Communication Terminal

部件名称 (Part name)	有毒有害物质或元素 (Toxic and Hazardous Substances and Elements)					
	铅 (Pb)	汞 (Hg)	镉 (Cd)	六价铬 (Cr ⁶⁺)	多溴联苯 (PBB)	多溴二苯醚 (PBDE)
卫星通信天线设备 (Above Deck Equipment)	-	-	-	-	-	-
· 天线罩 (Antenna Radome)	○	○	○	○	○	○
· 底座 (Pedestal)	○	○	○	○	○	○
· 天线控制单元 (Antenna Control Unit)	○	○	○	○	○	○
· 无线电单元 (Radio Frequency Unit)	○	○	○	○	○	○
卫星通信主机设备 (Below Deck Equipment)	-	-	-	-	-	-
· 机壳 (Chassis)	○	○	○	○	○	○
· 主板 (Interface Board)	○	○	○	○	○	○
· 电源板 (Power Board)	○	○	○	○	○	○
外部设备 (Peripherals)	-	-	-	-	-	-
· 特殊手持电话 (Handset)	○	○	○	○	○	○
· 电缆组件 (Cables)	○	○	○	○	○	○
· 手册 (Documents)	○	○	○	○	○	○
<p>○: 表示该有毒有害物质在该部件所有均质材料中的含量均在SJ/T11306-2006 标准规定的限量要求以下。 (Indicates that this toxic, or hazardous substance contained in all of the homogeneous materials for this part is below the requirement in SJ/T11363-2006.)</p> <p>×: 表示该有毒有害物质至少在该部件的某一均质材料中的含量超出SJ/T11363-2006 标准规定的限量要求。 (Indicates that this toxic or hazardous substance contained in at least one of the homogeneous materials used for this part is above the limit requirement in SJ/T 11363-2006.)</p>						

RE: 中华人民共和国电子信息产品污染控制管理办法
Management Methods on Control of Pollution from Electronics Information Products of the People's Republic of China

アスベストは使用しておりません
Not use the asbestos

CODE No.7ZPSC0427

For further information, contact:

JRC

Japan Radio Co., Ltd.

Since 1915

URL <http://www.jrc.co.jp>

Marine Service Department

Telephone : +81-3-3492-1305

Facsimile : +81-3-3779-1420

e-mail : tmsc@jrc.co.jp

AMSTERDAM Branch

Telephone : +31-20-658-0750

Facsimile : +31-20-658-0755

e-mail : service@jrceurope.com

SEATTLE Branch

Telephone : +1-206-654-5644

Facsimile : +1-206-654-7030

e-mail : marineservice@jrcaamerica.com

01ETM

ISO 9001, ISO 14001 Certified

©OCT. 2012 Edition 1 JRC

Printed in Japan