

# FURUNO

## OPERATOR'S MANUAL

COLOR NET RECORDER

MODEL CN-24



**FURUNO ELECTRIC CO., LTD.**  
NISHINOMIYA, JAPAN

© FURUNO ELECTRIC CO., LTD.

9-52, Ashihara-cho,  
Nishinomiya, Japan 662

Telephone: 0798-65-2111  
Telefax: 0798-65-4200

All rights reserved. Printed in Japan

•Your Local Agent/Dealer

FIRST EDITION : AUG 1996  
C : MAR. 30, 1998

(TATA)

PUB. No. OME-13010  
CN-24





# SAFETY INSTRUCTIONS

"**DANGER**", "**WARNING**" and "**CAUTION**" notices appear throughout this manual. It is the responsibility of the operator of the equipment to read, understand and follow these notices. If you have any questions regarding these safety instructions, please contact a FURUNO agent or dealer.



**DANGER**

This notice indicates a potentially hazardous situation which, if not avoided, will result in death or serious injury.



**WARNING**

This notice indicates a potentially hazardous situation which, if not avoided, could result in death or serious injury.



**CAUTION**

This notice indicates a potentially hazardous situation which, if not avoided, could result in minor or moderate injury, or property damage.



## DANGER



### Do not open the equipment.

Hazardous voltage which will cause death or serious injury exists inside the equipment. Only qualified personnel should work inside the equipment.



## WARNING

### Do not disassemble or modify the equipment.

Fire, electrical shock or serious injury can result.

### Turn off the power immediately if water leaks into the equipment or the equipment is emitting smoke or fire.

Continued use of the equipment can cause fire or electrical shock.

### Do not place liquid-filled containers on the top of the equipment.

Fire or electrical shock can result if a liquid spills into the equipment.

### Do not operate the equipment with wet hands.

Electrical shock can result.

### Keep heater away from equipment.

Heat can alter equipment shape and melt the power cord, which can cause fire or electrical shock.



## CAUTION

### Use the proper fuse.

Use of a wrong fuse can result in fire or permanent equipment damage.

### Do not use the equipment for other than its intended purpose.

Personal injury can result if the equipment is used as a chair or stepping stool, for example.

### Do not place objects on the top of the equipment.

The equipment can overheat or personal injury can result if the object falls.

### The battery in the transmitter unit may leak or explode if mishandled, which can result in personal injury. Care for the battery as follows:

- Do not dispose of the battery in fire or store it in a hot place.
- Do not short battery terminals.
- Use only the specified charger to charge the Ni-cd battery.
- Do not disassemble or modify the battery or solder battery terminals.
- Do not use the battery in other equipment; it is strictly for use with the net recorder.
- The alkaline in the battery can cause loss of eyesight. If it gets in eyes, flush immediately with water and contact a physician.

# CONTENTS

|                                                                          |      |
|--------------------------------------------------------------------------|------|
| A WORD TO FURUNO CN-24 OWNERS .....                                      | vii  |
| HOW THE NET-RECORDER WORKS .....                                         | viii |
| <br>                                                                     |      |
| CHAPTER 1. OPERATION OF DISPLAY UNIT .....                               | 1-1  |
| 1-1. CONTROL PANEL .....                                                 | 1-1  |
| Selecting Presentation Mode .....                                        | 1-2  |
| Selecting Basic Display Range .....                                      | 1-3  |
| Selecting Graphic Display (Water Temperature and Signal Strength) .....  | 1-3  |
| Selecting Picture Advancement Speed .....                                | 1-3  |
| Auto Shift .....                                                         | 1-5  |
| 1-2. MENU SCREEN SETTING .....                                           | 1-6  |
| Setting Procedure .....                                                  | 1-6  |
| Description of Menu Item .....                                           | 1-7  |
| Reprogramming Range Setting .....                                        | 1-9  |
| 1-3. OPERATING PROCEDURE .....                                           | 1-10 |
| <br>                                                                     |      |
| CHAPTER 2 . OBSERVATION OF PICTURE .....                                 | 2-1  |
| 2-1. PICTURE LAYOUT .....                                                | 2-1  |
| 2-2. HOW THE DISPLAY ADVANCES .....                                      | 2-2  |
| 2-3. INTERPRETATION OF PICTURE .....                                     | 2-3  |
| Transmission Line (TX Line) .....                                        | 2-3  |
| Seabed .....                                                             | 2-3  |
| Fish School .....                                                        | 2-4  |
| Ground Rope .....                                                        | 2-4  |
| Noise .....                                                              | 2-5  |
| Multiple Reflections .....                                               | 2-5  |
| 2-4. FISHING OPERATION AND PICTURE PRESENTATION .....                    | 2-6  |
| <br>                                                                     |      |
| CHAPTER 3 . OPERATION OF TRANSMITTER UNIT<br>AND PARAVANE RECEIVER ..... | 3-1  |
| 3-1. MOUNTING DIRECTION OF TRANSMITTER UNIT .....                        | 3-1  |
| 3-2. MOUNTING TRANSMITTER UNIT ONTO THE TRAWL .....                      | 3-2  |
| 3-3. OPERATION OF TRANSMITTER UNIT .....                                 | 3-5  |
| 3-4. PARAVANE RECEIVER .....                                             | 3-7  |
| Boom Installation .....                                                  | 3-7  |
| Wiring .....                                                             | 3-8  |
| Operation .....                                                          | 3-8  |
| Tilt Angle Adjustment .....                                              | 3-11 |
| Cable Length .....                                                       | 3-12 |
| Balancing Block .....                                                    | 3-12 |
| 3-5. SELECTION OF SOUNDING RANGE .....                                   | 3-13 |
| 3-6. SELECTION OF SOUNDING RATE .....                                    | 3-14 |
| 3-7. BATTERY CHANGER BC-8 (Option) .....                                 | 3-15 |
| 3-8. REPLACEMENT OF DRY CELLS .....                                      | 3-16 |

|                                                                                       |           |
|---------------------------------------------------------------------------------------|-----------|
| CHAPTER 4 . MAINTENANCE .....                                                         | 4-1       |
| 4-1. TRANSMITTER UNIT .....                                                           | 4-1       |
| O-rings Check .....                                                                   | 4-1       |
| Function Check .....                                                                  | 4-2       |
| 4-2. CHECK OF PARAVANE RECEIVER CABLE .....                                           | 4-3       |
| 4-3. REPLACEMENT OF TRANSDUCER ON PARAVANE RECEIVER .....                             | 4-4       |
| Replacement of Transducer .....                                                       | 4-5       |
| Replacement of Cabtyre Cable .....                                                    | 4-5       |
| 4-4. TESTING TRANSMITTER IN AIR .....                                                 | 4-6       |
| <br>CHAPTER 5. CHANGE OF INTERNAL SETTINGS IN DISPLAY UNIT<br>(for technicians) ..... | <br>5-1   |
| <br>CHAPTER 6. TROUBLESHOOTING .....                                                  | <br>6-1   |
| 6-1. SELF-CHECK .....                                                                 | 6-1       |
| 6-2. TROUBLESHOOTING FOR THE USER .....                                               | 6-2       |
| NO ECHOES APPEAR BUT SCALES AND VRM DO .....                                          | 6-2       |
| LOW SENSITIVITY (Seabed and fish school not well displayed) .....                     | 6-2       |
| PICTURE UNDULATES .....                                                               | 6-2       |
| PICTURE COLOR ABNORMAL .....                                                          | 6-2       |
| PICTURE COLOR PARTIALLY ABNORMAL .....                                                | 6-3       |
| OCCASIONAL DISTURBANCE/RANDOM NOISE .....                                             | 6-3       |
| NOISE/INTERFERENCE .....                                                              | 6-3       |
| <br>SPECIFICATIONS OF COLOR NET RECORDER CN-24 .....                                  | <br>SPC-1 |
| <br>APPENDIX A. Changing Signal Transmitting Power .....                              | <br>AP-1  |
| <br>APPENDIX B. Connecting with Echo Sounder FE-1282 .....                            | <br>AP-2  |
| <br>APPENDIX C. Plotting of Net Depth Mark on other Color Video/Echo Sounder .....    | <br>AP-2  |
| <br>APPENDIX D. Hull Bottom Transducers .....                                         | <br>AP-3  |
| Installation .....                                                                    | AP-3      |
| Transducer Switch Box (RS-80) .....                                                   | AP-4      |
| Operation .....                                                                       | AP-4      |
| <br>APPENDIX E. CN-2030 Paravane Receiver (optional supply) .....                     | <br>AP-5  |
| Operation .....                                                                       | AP-5      |
| Cable Length .....                                                                    | AP-5      |
| Tilt Angle Adjustment .....                                                           | AP-6      |
| Blancing Block .....                                                                  | AP-7      |
| Replacement of Transducer .....                                                       | AP-8      |

# A WORD TO FURUNO CN-24 OWNERS

---

Congratulations on your choice of the FURUNO CN-24 Color Net Recorder. We are confident that you will enjoy many years of operation with this fine piece of equipment.

For over 40 years FURUNO Electric Company has enjoyed an enviable reputation for quality and reliability throughout the world. This dedication to excellence is furthered by our extensive global network of agents and dealers.

The CN-24 Color Net Recorder is just one of the many FURUNO developments in the field of trawling. The compact, lightweight and rugged unit is easy to install and operate and is especially suited for deep-water and bottom trawlers.

This unit is designed and constructed to give the user many years of trouble-free operation. However, to obtain optimum performance from this unit, you should carefully read and follow the recommended procedures for installation, operation and maintenance. No machine can perform to the utmost of its ability unless it is installed and maintained properly.

We would appreciate feedback from you, the end-user, about whether we are achieving our purposes.

Thank you for considering and purchasing FURUNO equipment.

## Features

---

- *Pressure sensor provides reliable trawl net depth information.*
  - *Fish located above and below the net are graphically displayed on the screen.*
  - *Temperature sensor provides water temperature data, which is useful for searching target fish.*
  - *Improved transmission method provides high quality and low noise picture, allowing detailed observation of net height.*
  - *Historical Advancement mode provides maximum six hours of observation.*
-

# HOW THE NET-RECORDER WORKS

Echo sounders work by means of ultrasonic sounds and employ a transducer which works like a combination of a microphone and speaker, transmitting and receiving audible sounds. See Fig. 1.

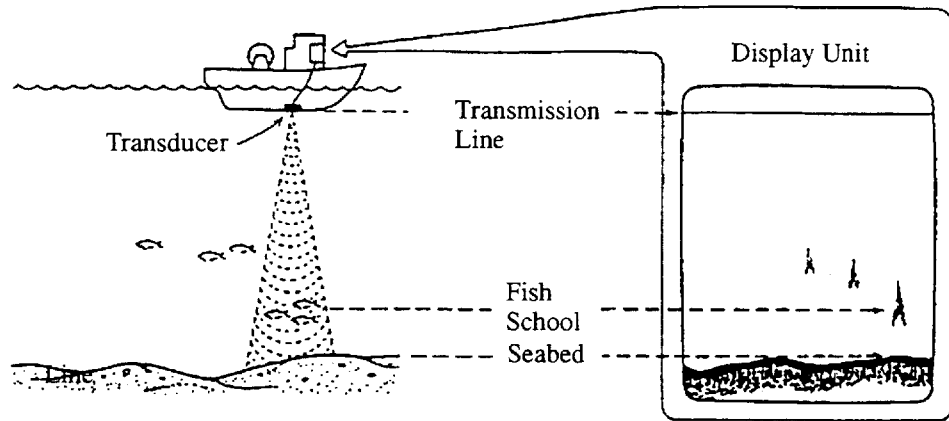

Fig. 1

The transducer for the echo sounder is fitted on the ship's hull. It transmits an ultrasonic wave downwards toward the sea bottom and receives reflected signals from fish, sea bottom, etc. If it is moved from ship's hull onto the trawl net, the information is given at the bridge. See Fig. 2.

- 1) Relationship between net and sea bottom
- 2) Height of the net opening
- 3) Fish entering the net

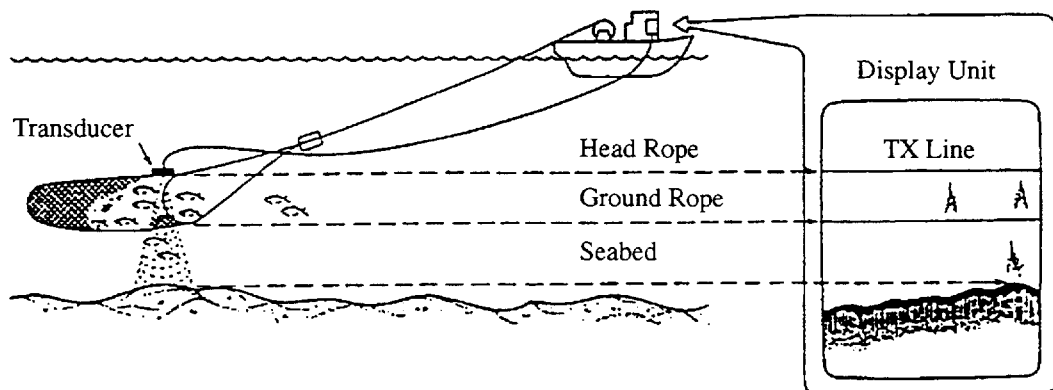
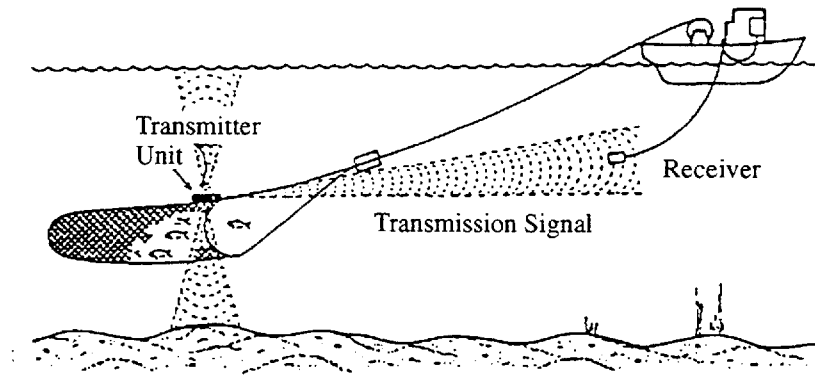

Fig. 2

Using this information the operator can assess whether the net is being towed properly or not. However, problems may arise when a very long transducer cable is used.



To solve these problems, FURUNO has developed a wireless net recorder. See Fig. 3.



*Fig. 3*

The device fitted on the net is called a TRANSMITTER UNIT and the device which picks up an ultrasonic signal, RECEIVER (RECEIVING TRANSDUCER). These units are the nucleus of a net recorder system.

For the CN-24, the transmitter emits a sounding wave toward and the upward and downward directions. Therefore, additional information such as net depth from the sea surface and the fish escaping over the net are also provided.

There are two types of receivers: 1) Towed receiver (standard supply) which is dropped in the water from the ship's sideboard and towed, and 2) Hull Bottom receiver.

## **Towed Receiver**

The towed receiver-equipped net recorder has been providing high-quality performance on board trawlers since the net recorder was first introduced in 1965. So, why is the performance of the towed receiver better than that of the hull bottom receiver?

To receive the ultrasonic signals effectively, the receiving transducer should be facing the transmitting transducer. Since the hull bottom receiver is fixed to the ship's hull reception of the signal from the transmitter may be interrupted if own ship changes its course. On the contrary, the towed receiver is always towed in the direction of the net even when own ship's course is changed, thus assuring continuous reception of the signal from the transmitter. Another merit of the towed receiver is that the effects of propeller noise are almost nil since it is not positioned in line with the propeller.

## **Hull Bottom Receiver**

One of the main features of the hull bottom receiver is that it is easier to use than the towed receiver. Because the transducer cable is laid inside the ship, the chances of it being cut by the propeller or being caught on the ship's hull, when the ship makes a sudden turn, are minimal comparing with the towed receiver system.

# CHAPTER 1

## OPERATION OF DISPLAY UNIT

### 1-1. CONTROL PANEL

The simple and logical layout of the control panel allows even the first time user to quickly become acquainted with its functions.

The diagram shows the control panel (CN-24) with various controls and their functions. The controls are arranged in a grid-like fashion. At the top, there are buttons for PWR and OFF. Below these are buttons for VRM (up and down arrows), ADVANC, and HUE. The next row contains buttons for GRAPH (TEMP and S-LVL), EVENT, and ALARM. Below that are buttons for SHIFT (minus and plus), AUTO, and MENU (ENT). The next row contains buttons for NORMAL and HIST. The bottom section features several rotary dials: 1/TM RANGE (1-4), MODE (MENU, up/down, TM), RANGE (1-4), BRILL (0-10), CLUTTER (0-10), and GAIN (0-10). Lines connect these controls to a table of functions.

| KEY/FUNCTION             | DESCRIPTION                                                                                                                                                                               | For Details |
|--------------------------|-------------------------------------------------------------------------------------------------------------------------------------------------------------------------------------------|-------------|
| PWR, OFF                 | Turn the equipment on/off. The <b>PWR</b> key turns the equipment on. To turn the equipment off, press the keys together.                                                                 |             |
| VRM                      | Adjusts the variable range marker (VRM). The depth from the transmitter unit (or surface in TM mode) appears on the marker.                                                               |             |
| HUE                      | Selects background color (deep blue or black).                                                                                                                                            |             |
| PICTURE ADVANCEMENT      | Selects the picture advancement speed at NORMAL display selection. Position "1" offers the slowest speed. For normal use, select "5".                                                     |             |
| GRAPH                    | <b>TEMP</b> turns the graphic display of water temperature at net position on/off. <b>S-LVL</b> turns the bar graph display of signal strength on/off.                                    | P1-3        |
| ALARM                    | Silences the alarm temporarily.                                                                                                                                                           |             |
| EVENT Marker             | Draws the event marker (reddish brown vertical line), which marks elapsed time or important points.                                                                                       |             |
| SHIFT/AUTO SHIFT         | The <b>-</b> and <b>+</b> keys shift the TM range. The <b>AUTO</b> key turns on/off the automatic net tracking.                                                                           |             |
| MENU Setting             | These keys function to select items and enter data on the MENU screen.                                                                                                                    |             |
| PICTURE ADVANCEMENT MODE | These keys select the picture advancement mode: <b>NORMAL</b> for NORMAL mode; <b>HIST</b> for slow mode. The picture advance speed of Historical display is selected on the MENU screen. | P1-4        |
| PRESENTATION MODE        | Selects the presentation mode.                                                                                                                                                            | P1-2        |
| BRILLIANCE               | Adjusts screen brightness.                                                                                                                                                                |             |
| BASIC RANGE (↑/TM)       | Selects the upward + downward/True Motion (TM) range.                                                                                                                                     |             |
| BASIC RANGE (↓)          | Selects the downward display range.                                                                                                                                                       |             |
| GAIN                     | Adjusts receiver gain. Turning it clockwise increases the gain.                                                                                                                           |             |
| CLUTTER                  | Adjusts the level of clutter reduction. Turn it clockwise to eliminate low level noise. Do not use too high a setting. Weak echoes may be lost.                                           |             |

## Selecting Presentation Mode

Three presentation modes are available: Downward mode, Upward + Downward + Downward and True Motion modes.

| Mode | Presentation                                                                                                                                                                                                                                                                                                                                |
|------|---------------------------------------------------------------------------------------------------------------------------------------------------------------------------------------------------------------------------------------------------------------------------------------------------------------------------------------------|
| ↓    | <p style="text-align: center;">(Downward) Mode</p>  <p>Displays downward sounding picture on the entire screen.</p>                                                                                                                                       |
| ↑↓   | <p style="text-align: center;">(Upward + Downward) Mode</p>  <p>Displays upward sounding picture on the upper half and downward sounding picture on the lower half.</p>                                                                                  |
| TM   | <p style="text-align: center;">TM (True Motion) Mode</p>  <p>The TM mode picture, where the sea surface is locked at the screen top and all echoes are presented in their true depth, enables the operator to monitor the true motion of the trawl.</p> |

Fig. 1-1

Notes 1) Selection of ↑↓ or TM mode is made on the MENU screen.

2) Above pictures show NORMAL picture advancement mode.

## Selecting Basic Display Range

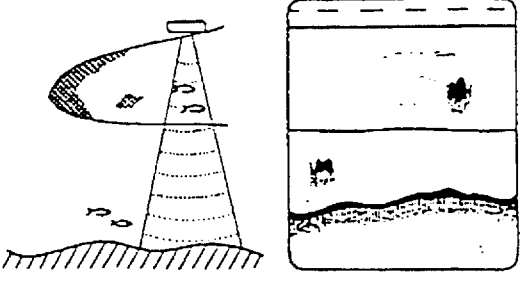
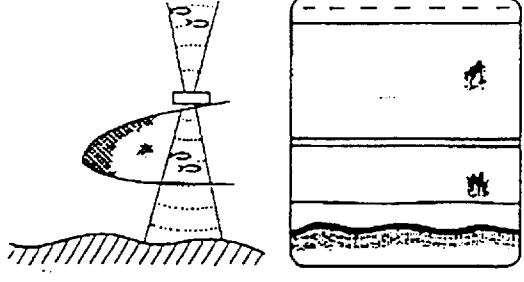
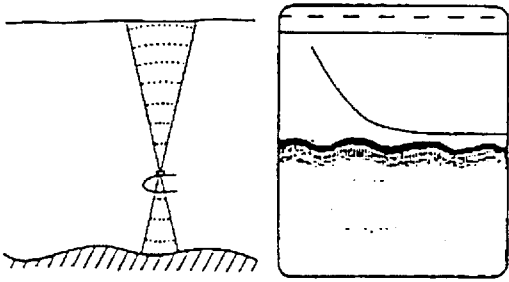
The basic range may be selected with the **↑/TM RANGE** or **↓RANGE** knob from the four ranges listed below. The four ranges are operator-programmable on the MENU screen. For further details, see page 1-9.

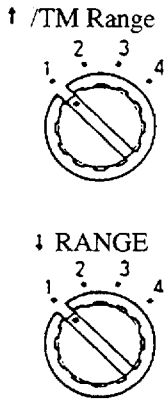

|                           |                      | 1  | 2  | 3  | 4   |
|---------------------------|----------------------|----|----|----|-----|
| Downward/<br>Upward Range | M<br>FT<br>FA<br>P/B | 10 | 20 | 30 | 40  |
| TM Range                  | M<br>FT<br>FA<br>P/B | 20 | 40 | 80 | 160 |

## Selecting Graphic Display (Water Temperature and Signal Strength)

The graphic displays may be turned on/off with the **TEMP** and **S-LVL** keys.

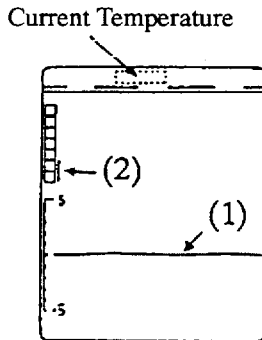

(1) The **TEMP** key turns the graphic display of water temperature (range of 10°C or 20°F) at net position on/off. If the temperature rises above or falls below the limits of the scale, the graph shifts so the temperature marker comes to the center of the scale. Current temperature appears at the upper center of the screen.

(2) The **S-LVL** key switches the graphic display of signal strength on/off.

The strength of signals received by the paravane receiver appears in bar graph form beside the color pattern. Adjust the position of the paravane receiver for clearest picture and maximum signal strength.

Note: When **S-LVL** key is turned on, the color pattern appears on the upper left of the screen even if it is set to off on the MENU.

## Selecting Picture Advancement Speed

In normal picture advancement mode, the speed is selected by the **ADVANC** key as follows.

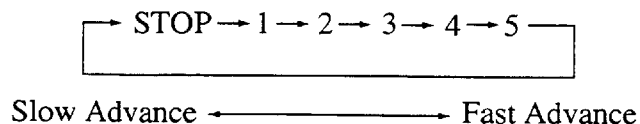

For the HISTorical advancement mode, the speed selection is made on the Menu screen. See below.

| Mode                   | Menu Item  | Sub-Menu Description                                                                                                                                                                                                                                                                                                                                                                                                                                                                                    |          |         |    |    |    |    |    |     |
|------------------------|------------|---------------------------------------------------------------------------------------------------------------------------------------------------------------------------------------------------------------------------------------------------------------------------------------------------------------------------------------------------------------------------------------------------------------------------------------------------------------------------------------------------------|----------|---------|----|----|----|----|----|-----|
| HISTorical Advancement | [HIST ADV] | <table border="1" style="display: inline-table; vertical-align: middle;"> <tr><td>HIST ADV</td></tr> <tr><td>* 5 MIN</td></tr> <tr><td>10</td></tr> <tr><td>15</td></tr> <tr><td>30</td></tr> <tr><td>60</td></tr> <tr><td>90</td></tr> <tr><td>120</td></tr> </table> <div style="display: inline-block; vertical-align: middle; margin-left: 20px;">           Fast advance<br/>           ↑<br/>           ↓<br/>           Slow advance         </div> <p>Time required to paint entire screen.</p> | HIST ADV | * 5 MIN | 10 | 15 | 30 | 60 | 90 | 120 |
| HIST ADV               |            |                                                                                                                                                                                                                                                                                                                                                                                                                                                                                                         |          |         |    |    |    |    |    |     |
| * 5 MIN                |            |                                                                                                                                                                                                                                                                                                                                                                                                                                                                                                         |          |         |    |    |    |    |    |     |
| 10                     |            |                                                                                                                                                                                                                                                                                                                                                                                                                                                                                                         |          |         |    |    |    |    |    |     |
| 15                     |            |                                                                                                                                                                                                                                                                                                                                                                                                                                                                                                         |          |         |    |    |    |    |    |     |
| 30                     |            |                                                                                                                                                                                                                                                                                                                                                                                                                                                                                                         |          |         |    |    |    |    |    |     |
| 60                     |            |                                                                                                                                                                                                                                                                                                                                                                                                                                                                                                         |          |         |    |    |    |    |    |     |
| 90                     |            |                                                                                                                                                                                                                                                                                                                                                                                                                                                                                                         |          |         |    |    |    |    |    |     |
| 120                    |            |                                                                                                                                                                                                                                                                                                                                                                                                                                                                                                         |          |         |    |    |    |    |    |     |

**Procedure**

- 1) Set the MODE switch to the MENU position to get into the MENU screen.
- 2) Press the  to select "HIST ADV".
- 3) Press the  key to display the picture advancement speed sub-menu.
- 4) Press the  or  to move the asterisk (\*) beside the selection desired.
- 5) Press  the key to enter the selection.

**For your reference ---**

In the historical mode, the slowest advance speed takes two hours to fill the screen. In the downward mode, the screen is vertically divided in three parts to give you up to six hours of observation.

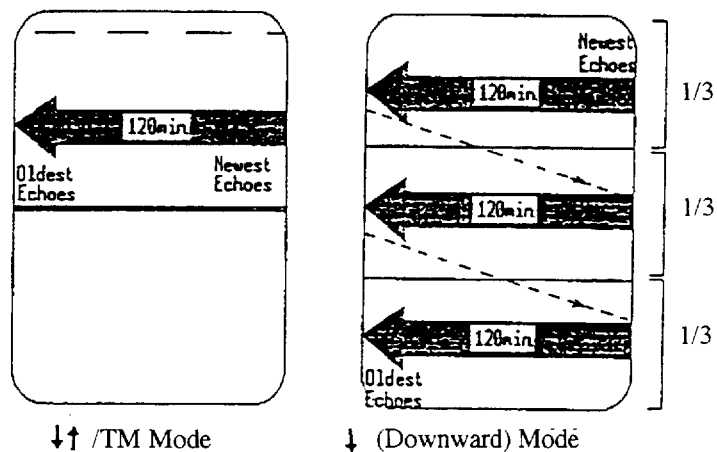
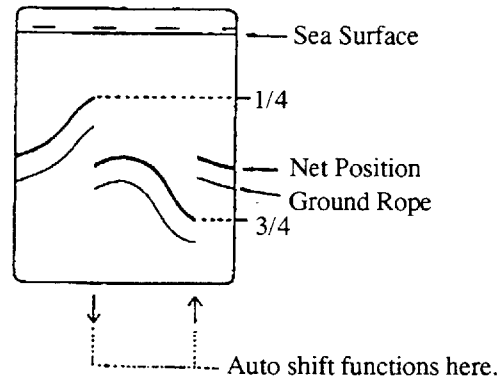

Fig. 1-2

## Auto Shift

The auto shift function automatically locates the net trace between 1/4 and 3/4 of the screen in the TM mode.

The range window jumps up when the net trace rises over 3/4 of the screen and jumps down when it reaches 1/4 of the screen from the bottom.



*Fig. 1-3 Auto Shift in TM Mode*

## 1-2. MENU SCREEN SETTING

The menu screen appears when the MODE switch is in the "MENU" position. It allows you to set or select those functions that are not frequently altered in daily use.

There are two pages of menu screens:

- (1) DSP MENU ----- For setting the display items on the screen.
- (2) RANGE MENU ----- For setting the range window.

### Setting Procedure

1. Set the MODE switch to the "MENU" position.
2. Press the  or  to select item. The item selected appears in white highlight.
3. Press the  key. The highlight will shift to the top line of the sub-menu and the parameters appear below it.
4. Press the  or  to place the asterisk(\*) beside the parameter desired, or change the parameter.
5. Press the  key to register the parameter selected. All messages on the sub-menu disappear and the highlight will shift back to the main menu.
6. Turn the MODE switch to another position to restore the normal picture.

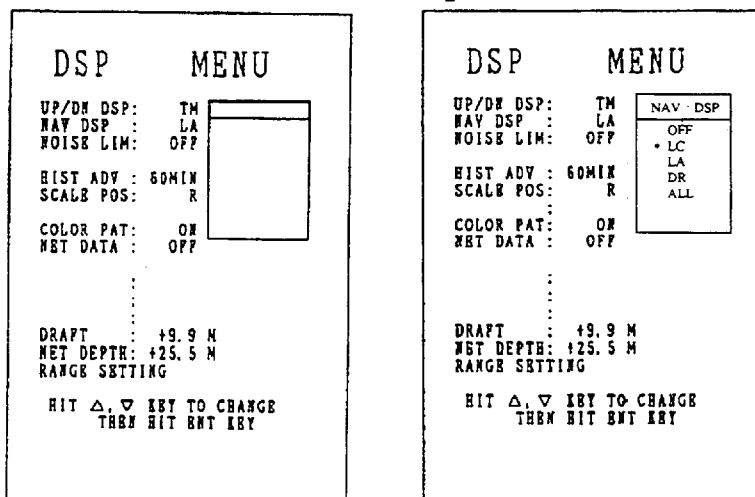

Fig. 1-4

## Description of Menu Item

| Item      | Sub-Menu                                                                                                                                                                                                                                                                                                                                                                                                                                                                                        | Descriptions |         |        |                                                                                                                                                                                                                                                                                                                                                                                           |    |                                                                                                                                                                                                                                                                                                                                                                                                                                           |                                                                                                                                                                                                                                                                                                                                                                                                                                                                                                          |     |                                                                                                                                                                                                     |
|-----------|-------------------------------------------------------------------------------------------------------------------------------------------------------------------------------------------------------------------------------------------------------------------------------------------------------------------------------------------------------------------------------------------------------------------------------------------------------------------------------------------------|--------------|---------|--------|-------------------------------------------------------------------------------------------------------------------------------------------------------------------------------------------------------------------------------------------------------------------------------------------------------------------------------------------------------------------------------------------|----|-------------------------------------------------------------------------------------------------------------------------------------------------------------------------------------------------------------------------------------------------------------------------------------------------------------------------------------------------------------------------------------------------------------------------------------------|----------------------------------------------------------------------------------------------------------------------------------------------------------------------------------------------------------------------------------------------------------------------------------------------------------------------------------------------------------------------------------------------------------------------------------------------------------------------------------------------------------|-----|-----------------------------------------------------------------------------------------------------------------------------------------------------------------------------------------------------|
| UP/DN DSP | <table border="1" style="width: 100%; border-collapse: collapse;"> <tr><td style="text-align: center;">UP/DN DSP</td></tr> <tr><td style="text-align: center;">* TM</td></tr> <tr><td style="text-align: center;">NORMAL</td></tr> </table>                                                                                                                                                                                                                                                     | UP/DN DSP    | * TM    | NORMAL | <p>Selects the presentation mode for the Upward + Downward display.</p> <p>TM ----- The sea surface is displayed with a straight line at the screen top and echoes appear in their true depth.</p> <p>NORMAL --- The transmitter is displayed with a straight line at the center of the screen and upward sounding appears on the upper half and downward sounding on the lower half.</p> |    |                                                                                                                                                                                                                                                                                                                                                                                                                                           |                                                                                                                                                                                                                                                                                                                                                                                                                                                                                                          |     |                                                                                                                                                                                                     |
| UP/DN DSP |                                                                                                                                                                                                                                                                                                                                                                                                                                                                                                 |              |         |        |                                                                                                                                                                                                                                                                                                                                                                                           |    |                                                                                                                                                                                                                                                                                                                                                                                                                                           |                                                                                                                                                                                                                                                                                                                                                                                                                                                                                                          |     |                                                                                                                                                                                                     |
| * TM      |                                                                                                                                                                                                                                                                                                                                                                                                                                                                                                 |              |         |        |                                                                                                                                                                                                                                                                                                                                                                                           |    |                                                                                                                                                                                                                                                                                                                                                                                                                                           |                                                                                                                                                                                                                                                                                                                                                                                                                                                                                                          |     |                                                                                                                                                                                                     |
| NORMAL    |                                                                                                                                                                                                                                                                                                                                                                                                                                                                                                 |              |         |        |                                                                                                                                                                                                                                                                                                                                                                                           |    |                                                                                                                                                                                                                                                                                                                                                                                                                                           |                                                                                                                                                                                                                                                                                                                                                                                                                                                                                                          |     |                                                                                                                                                                                                     |
| NAV DSP   | <table border="1" style="width: 100%; border-collapse: collapse;"> <tr><td style="text-align: center;">NAV DSP</td></tr> <tr><td style="text-align: center;">OFF</td></tr> <tr><td style="text-align: center;">* LC</td></tr> <tr><td style="text-align: center;">LA</td></tr> <tr><td style="text-align: center;">DR</td></tr> <tr><td style="text-align: center;">ALL</td></tr> </table>                                                                                                      | NAV DSP      | OFF     | * LC   | LA                                                                                                                                                                                                                                                                                                                                                                                        | DR | ALL                                                                                                                                                                                                                                                                                                                                                                                                                                       | <p>If a navigation device is connected to the CN-24, ship's position can be displayed on the screen. This sub-menu selects the source of ship's position data.</p> <p>OFF --- Position data is not displayed.</p> <p>LC ---- Loran C navigator</p> <p>LA ---- Loran A navigator</p> <p>DR ---- DR navigation (Sat-nav connected with gyro and log)</p> <p>ALL--- Omega or other navigation equipment</p> <p>Note: For sat-nav combined with Loran-A or C in FURUNO CIF data format, select LA or LC.</p> |     |                                                                                                                                                                                                     |
| NAV DSP   |                                                                                                                                                                                                                                                                                                                                                                                                                                                                                                 |              |         |        |                                                                                                                                                                                                                                                                                                                                                                                           |    |                                                                                                                                                                                                                                                                                                                                                                                                                                           |                                                                                                                                                                                                                                                                                                                                                                                                                                                                                                          |     |                                                                                                                                                                                                     |
| OFF       |                                                                                                                                                                                                                                                                                                                                                                                                                                                                                                 |              |         |        |                                                                                                                                                                                                                                                                                                                                                                                           |    |                                                                                                                                                                                                                                                                                                                                                                                                                                           |                                                                                                                                                                                                                                                                                                                                                                                                                                                                                                          |     |                                                                                                                                                                                                     |
| * LC      |                                                                                                                                                                                                                                                                                                                                                                                                                                                                                                 |              |         |        |                                                                                                                                                                                                                                                                                                                                                                                           |    |                                                                                                                                                                                                                                                                                                                                                                                                                                           |                                                                                                                                                                                                                                                                                                                                                                                                                                                                                                          |     |                                                                                                                                                                                                     |
| LA        |                                                                                                                                                                                                                                                                                                                                                                                                                                                                                                 |              |         |        |                                                                                                                                                                                                                                                                                                                                                                                           |    |                                                                                                                                                                                                                                                                                                                                                                                                                                           |                                                                                                                                                                                                                                                                                                                                                                                                                                                                                                          |     |                                                                                                                                                                                                     |
| DR        |                                                                                                                                                                                                                                                                                                                                                                                                                                                                                                 |              |         |        |                                                                                                                                                                                                                                                                                                                                                                                           |    |                                                                                                                                                                                                                                                                                                                                                                                                                                           |                                                                                                                                                                                                                                                                                                                                                                                                                                                                                                          |     |                                                                                                                                                                                                     |
| ALL       |                                                                                                                                                                                                                                                                                                                                                                                                                                                                                                 |              |         |        |                                                                                                                                                                                                                                                                                                                                                                                           |    |                                                                                                                                                                                                                                                                                                                                                                                                                                           |                                                                                                                                                                                                                                                                                                                                                                                                                                                                                                          |     |                                                                                                                                                                                                     |
| NOISE LIM | <table border="1" style="width: 100%; border-collapse: collapse;"> <tr><td style="text-align: center;">NOISE LIM</td></tr> <tr><td style="text-align: center;">* OFF</td></tr> <tr><td style="text-align: center;">1</td></tr> <tr><td style="text-align: center;">2</td></tr> <tr><td style="text-align: center;">3</td></tr> </table>                                                                                                                                                         | NOISE LIM    | * OFF   | 1      | 2                                                                                                                                                                                                                                                                                                                                                                                         | 3  | <p>When the interference from other echo sounders operating nearby or other types of electrical interference exist, you may use the noise limiter to eliminate or reduce the interference. The "OFF" position turns off the noise limiter function. Position "3" offers the highest degree of noise rejection.</p> <p>Note: If the noise limiter is left in "3" when no interference exists, weak echoes may be missed or eliminated.</p> |                                                                                                                                                                                                                                                                                                                                                                                                                                                                                                          |     |                                                                                                                                                                                                     |
| NOISE LIM |                                                                                                                                                                                                                                                                                                                                                                                                                                                                                                 |              |         |        |                                                                                                                                                                                                                                                                                                                                                                                           |    |                                                                                                                                                                                                                                                                                                                                                                                                                                           |                                                                                                                                                                                                                                                                                                                                                                                                                                                                                                          |     |                                                                                                                                                                                                     |
| * OFF     |                                                                                                                                                                                                                                                                                                                                                                                                                                                                                                 |              |         |        |                                                                                                                                                                                                                                                                                                                                                                                           |    |                                                                                                                                                                                                                                                                                                                                                                                                                                           |                                                                                                                                                                                                                                                                                                                                                                                                                                                                                                          |     |                                                                                                                                                                                                     |
| 1         |                                                                                                                                                                                                                                                                                                                                                                                                                                                                                                 |              |         |        |                                                                                                                                                                                                                                                                                                                                                                                           |    |                                                                                                                                                                                                                                                                                                                                                                                                                                           |                                                                                                                                                                                                                                                                                                                                                                                                                                                                                                          |     |                                                                                                                                                                                                     |
| 2         |                                                                                                                                                                                                                                                                                                                                                                                                                                                                                                 |              |         |        |                                                                                                                                                                                                                                                                                                                                                                                           |    |                                                                                                                                                                                                                                                                                                                                                                                                                                           |                                                                                                                                                                                                                                                                                                                                                                                                                                                                                                          |     |                                                                                                                                                                                                     |
| 3         |                                                                                                                                                                                                                                                                                                                                                                                                                                                                                                 |              |         |        |                                                                                                                                                                                                                                                                                                                                                                                           |    |                                                                                                                                                                                                                                                                                                                                                                                                                                           |                                                                                                                                                                                                                                                                                                                                                                                                                                                                                                          |     |                                                                                                                                                                                                     |
| HIST ADV  | <table border="1" style="width: 100%; border-collapse: collapse;"> <tr><td style="text-align: center;">HIST ADV</td></tr> <tr><td style="text-align: center;">* 5 MIN</td></tr> <tr><td style="text-align: center;">10</td></tr> <tr><td style="text-align: center;">15</td></tr> <tr><td style="text-align: center;">30</td></tr> <tr><td style="text-align: center;">60</td></tr> <tr><td style="text-align: center;">90</td></tr> <tr><td style="text-align: center;">120</td></tr> </table> | HIST ADV     | * 5 MIN | 10     | 15                                                                                                                                                                                                                                                                                                                                                                                        | 30 | 60                                                                                                                                                                                                                                                                                                                                                                                                                                        | 90                                                                                                                                                                                                                                                                                                                                                                                                                                                                                                       | 120 | <p>Picture advancement speed selection for the HISTorical advancement mode.</p> <p>The speed is the time which it takes for an echo to move from the right edge to the left edge of the screen.</p> |
| HIST ADV  |                                                                                                                                                                                                                                                                                                                                                                                                                                                                                                 |              |         |        |                                                                                                                                                                                                                                                                                                                                                                                           |    |                                                                                                                                                                                                                                                                                                                                                                                                                                           |                                                                                                                                                                                                                                                                                                                                                                                                                                                                                                          |     |                                                                                                                                                                                                     |
| * 5 MIN   |                                                                                                                                                                                                                                                                                                                                                                                                                                                                                                 |              |         |        |                                                                                                                                                                                                                                                                                                                                                                                           |    |                                                                                                                                                                                                                                                                                                                                                                                                                                           |                                                                                                                                                                                                                                                                                                                                                                                                                                                                                                          |     |                                                                                                                                                                                                     |
| 10        |                                                                                                                                                                                                                                                                                                                                                                                                                                                                                                 |              |         |        |                                                                                                                                                                                                                                                                                                                                                                                           |    |                                                                                                                                                                                                                                                                                                                                                                                                                                           |                                                                                                                                                                                                                                                                                                                                                                                                                                                                                                          |     |                                                                                                                                                                                                     |
| 15        |                                                                                                                                                                                                                                                                                                                                                                                                                                                                                                 |              |         |        |                                                                                                                                                                                                                                                                                                                                                                                           |    |                                                                                                                                                                                                                                                                                                                                                                                                                                           |                                                                                                                                                                                                                                                                                                                                                                                                                                                                                                          |     |                                                                                                                                                                                                     |
| 30        |                                                                                                                                                                                                                                                                                                                                                                                                                                                                                                 |              |         |        |                                                                                                                                                                                                                                                                                                                                                                                           |    |                                                                                                                                                                                                                                                                                                                                                                                                                                           |                                                                                                                                                                                                                                                                                                                                                                                                                                                                                                          |     |                                                                                                                                                                                                     |
| 60        |                                                                                                                                                                                                                                                                                                                                                                                                                                                                                                 |              |         |        |                                                                                                                                                                                                                                                                                                                                                                                           |    |                                                                                                                                                                                                                                                                                                                                                                                                                                           |                                                                                                                                                                                                                                                                                                                                                                                                                                                                                                          |     |                                                                                                                                                                                                     |
| 90        |                                                                                                                                                                                                                                                                                                                                                                                                                                                                                                 |              |         |        |                                                                                                                                                                                                                                                                                                                                                                                           |    |                                                                                                                                                                                                                                                                                                                                                                                                                                           |                                                                                                                                                                                                                                                                                                                                                                                                                                                                                                          |     |                                                                                                                                                                                                     |
| 120       |                                                                                                                                                                                                                                                                                                                                                                                                                                                                                                 |              |         |        |                                                                                                                                                                                                                                                                                                                                                                                           |    |                                                                                                                                                                                                                                                                                                                                                                                                                                           |                                                                                                                                                                                                                                                                                                                                                                                                                                                                                                          |     |                                                                                                                                                                                                     |



|               |                                                                                                                                       |           |         |       |                                                                    |                                                                                                                                                                                                                                        |
|---------------|---------------------------------------------------------------------------------------------------------------------------------------|-----------|---------|-------|--------------------------------------------------------------------|----------------------------------------------------------------------------------------------------------------------------------------------------------------------------------------------------------------------------------------|
| SCALE POS     | <table border="1"> <tr><td>SCALE POS</td></tr> <tr><td>* OFF</td></tr> <tr><td>R</td></tr> <tr><td>C</td></tr> </table>               | SCALE POS | * OFF   | R     | C                                                                  | <p>Selects the presentation position of the depth scale.</p> <p>OFF --- Turns the depth scale off.<br/> R ----- Depth scale appears at the right edge of the screen.<br/> C ----- Depth scale appears at the center of the screen.</p> |
| SCALE POS     |                                                                                                                                       |           |         |       |                                                                    |                                                                                                                                                                                                                                        |
| * OFF         |                                                                                                                                       |           |         |       |                                                                    |                                                                                                                                                                                                                                        |
| R             |                                                                                                                                       |           |         |       |                                                                    |                                                                                                                                                                                                                                        |
| C             |                                                                                                                                       |           |         |       |                                                                    |                                                                                                                                                                                                                                        |
| COLOR PAT     | <table border="1"> <tr><td>COLOR PAT</td></tr> <tr><td>* OFF</td></tr> <tr><td>ON</td></tr> </table>                                  | COLOR PAT | * OFF   | ON    | <p>Switches the color pattern display on/off.</p>                  |                                                                                                                                                                                                                                        |
| COLOR PAT     |                                                                                                                                       |           |         |       |                                                                    |                                                                                                                                                                                                                                        |
| * OFF         |                                                                                                                                       |           |         |       |                                                                    |                                                                                                                                                                                                                                        |
| ON            |                                                                                                                                       |           |         |       |                                                                    |                                                                                                                                                                                                                                        |
| NET DATA      | <table border="1"> <tr><td>NET DATA</td></tr> <tr><td>* OFF</td></tr> <tr><td>ON</td></tr> </table>                                   | NET DATA  | * OFF   | ON    | <p>Turns the net data (net depth, temperature) display on/off.</p> |                                                                                                                                                                                                                                        |
| NET DATA      |                                                                                                                                       |           |         |       |                                                                    |                                                                                                                                                                                                                                        |
| * OFF         |                                                                                                                                       |           |         |       |                                                                    |                                                                                                                                                                                                                                        |
| ON            |                                                                                                                                       |           |         |       |                                                                    |                                                                                                                                                                                                                                        |
| DRAFT         | <table border="1"> <tr><td>DRAFT</td></tr> <tr><td>-9.9 -</td></tr> <tr><td>+9.9</td></tr> <tr><td>* +9.9 M</td></tr> </table>        | DRAFT     | -9.9 -  | +9.9  | * +9.9 M                                                           | <p>This item permits settings of ship's draft, between -9.9 and +9.9 (m), in order to plot the net depth mark at the correct depth on the external echo sounder. Set to 0.0 if the echo sounder incorporates a draft control.</p>      |
| DRAFT         |                                                                                                                                       |           |         |       |                                                                    |                                                                                                                                                                                                                                        |
| -9.9 -        |                                                                                                                                       |           |         |       |                                                                    |                                                                                                                                                                                                                                        |
| +9.9          |                                                                                                                                       |           |         |       |                                                                    |                                                                                                                                                                                                                                        |
| * +9.9 M      |                                                                                                                                       |           |         |       |                                                                    |                                                                                                                                                                                                                                        |
| NET DEPTH     | <table border="1"> <tr><td>NET DEPTH</td></tr> <tr><td>-99.9 -</td></tr> <tr><td>+99.9</td></tr> <tr><td>* +99.9 M</td></tr> </table> | NET DEPTH | -99.9 - | +99.9 | * +99.9 M                                                          | <p>Compensates for net depth error. The range of compensation is -99.9 ~ +99.9.</p>                                                                                                                                                    |
| NET DEPTH     |                                                                                                                                       |           |         |       |                                                                    |                                                                                                                                                                                                                                        |
| -99.9 -       |                                                                                                                                       |           |         |       |                                                                    |                                                                                                                                                                                                                                        |
| +99.9         |                                                                                                                                       |           |         |       |                                                                    |                                                                                                                                                                                                                                        |
| * +99.9 M     |                                                                                                                                       |           |         |       |                                                                    |                                                                                                                                                                                                                                        |
| RANGE SETTING | <p>Permits reprogramming of the factory-set ranges.<br/> For details, see next page.</p>                                              |           |         |       |                                                                    |                                                                                                                                                                                                                                        |

## Reprogramming Range Setting

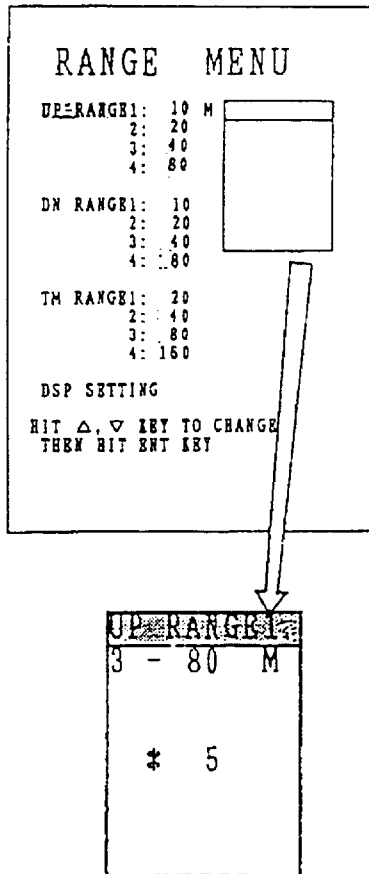

1. Select the "RANGE SETTING" item and press the **ENT** key on the DSP MENU screen. The RANGE MENU appears as shown at left.
2. Press the **▲** or **▼** to select range to reprogram. Then press the **ENT** key. The top line of the sub menu appears in highlight, showing the unit is ready for reprogramming.
3. Press the **▲** or **▼** key until the desired range appears.
4. Press the **ENT** key to register the range set in step #3.
5. Repeat steps #2 to 4 to reprogram other ranges.
6. To exit from the range menu, select the "DSP SETTING" and press the **ENT** key, or turn the MODE switch to another position.

Note: When selecting a range more than 80 m, alteration of sounding range setting is required in the display unit (DSP board) and the transmitter unit.  
See pages 3-13 and 5-2.

### For your reference ---

(Available Ranges)

|                           |     | 1       | 2      | 3       | 4       |
|---------------------------|-----|---------|--------|---------|---------|
| Upward/<br>Downward Range | M   | 3-80    | 3-160  | 3-320   | 3-640   |
|                           | FT  | 10-260  | 10-520 | 10-1040 | 10-2080 |
|                           | FA  | 2-40    | 2-80   | 2-160   | 2-320   |
|                           | P/B | 2-45    | 2-90   | 2-180   | 2-360   |
| TM Range                  | M   | 3-2000  |        |         |         |
|                           | FT  | 10-7000 |        |         |         |
|                           | FA  | 2-1100  |        |         |         |
|                           | P/B | 2-1200  |        |         |         |

## 1-3. OPERATING PROCEDURE

- 1 Load the battery into the transmitter unit.
- 2 Mount the transmitter unit on the trawl.
- 3 Shoot the trawl and put the paravane receiver into the water.
- 4 Turn on the display unit.
- 5 Adjust the screen brilliance.
- 6 Select the presentation mode and NORMAL picture advancement speed.
- 7 Select a Basic Range.
- 8 Adjust the GAIN and CLUTTER for clear picture.
- 9 Watching both the picture and the signal level, adjust the length of the paravane receiver cable for a clear and steady picture.
- 10 Change the presentation mode if necessary.

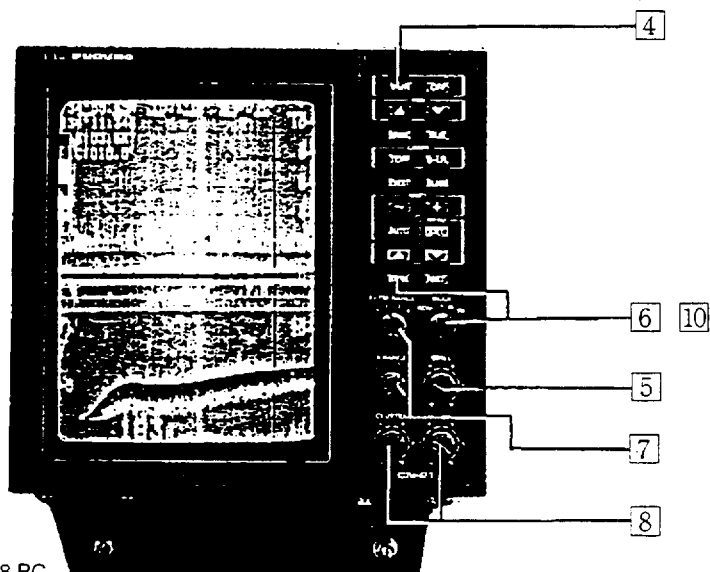

F Photo No.1938 PC

# CHAPTER 2 OBSERVATION OF PICTURE

## 2-1. PICTURE LAYOUT

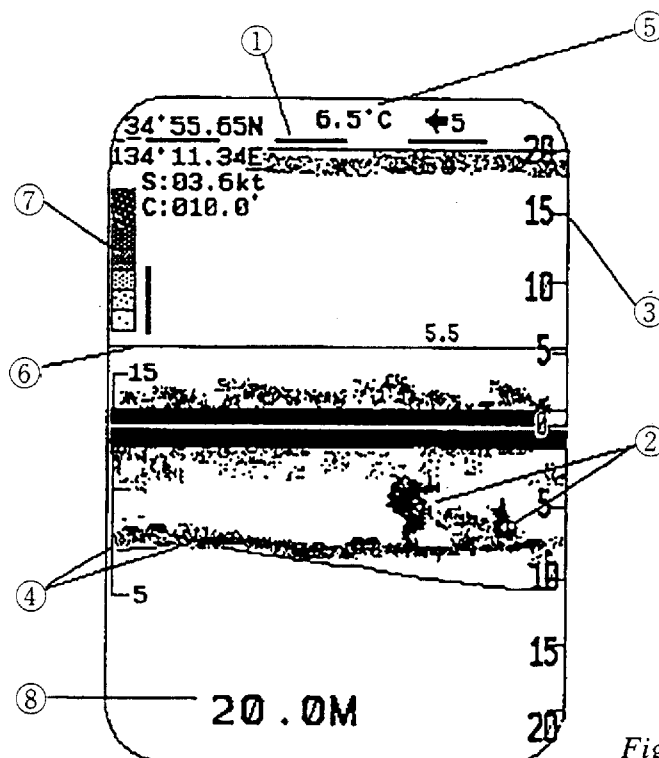

Fig. 2-1

- ① Minute Mark: plotted in yellow for 30 seconds every minute.
- ② Echoes: painted in 7 different colors depending on their intensity. The strongest echoes in reddish brown and the weakest in blue, as shown in the color bar at the left upper edge on the screen ⑦.
- ③ Range Scale: calibrated in meters, fathoms, feet or passis/brazas and displayed in white.
- ④ Temp. Scale/  
⑤ Temp. display: The temperature scale, painted in white, is calibrated to  $\pm 5^{\circ}\text{C}$  or  $\pm 10^{\circ}\text{F}$  ranges. Current water temperature appears at the screen top, and past water temperature is graphically overlaid in light blue on the echo picture.
- ⑥ VRM: measures depth and appears in green. Depth appears above the marker.
- ⑧ Depth Readout: indicates the net depth (transmitter) from the sea surface.

## 2-2. HOW THE DISPLAY ADVANCES

In the conventional paper type net recorder, the paper advances even if there is no signal coming from the transmitter unit, that is, even if the signal link between the transmitter unit and paravane receiver is lost. In the color net recorder, however, the display advances only when the signal is received. Thus if the signal is interrupted for say a few minutes, a blank space appears on the paper in the paper type net recorder, but in the color net recorder it appears only as jumping of the picture as shown below.

Signal interruption is also recognized by observing the minute marks: The minute mark is irregularly spaced if display advancement stops for a short period.

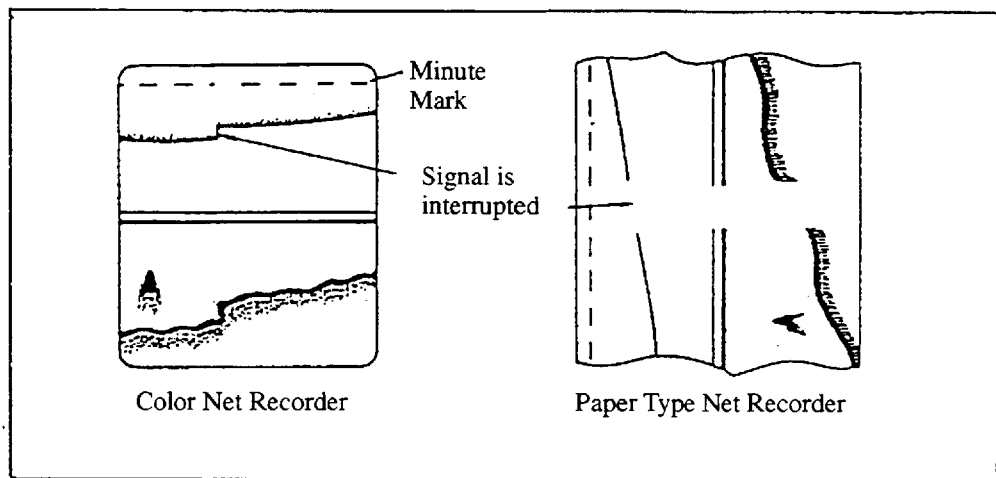

*Fig. 2-2*

## 2-3. INTERPRETATION OF PICTURE

This section describes how to interpret the picture. Examples shown are pictures in the "upward + downward" mode and the "True Motion (TM)" mode.

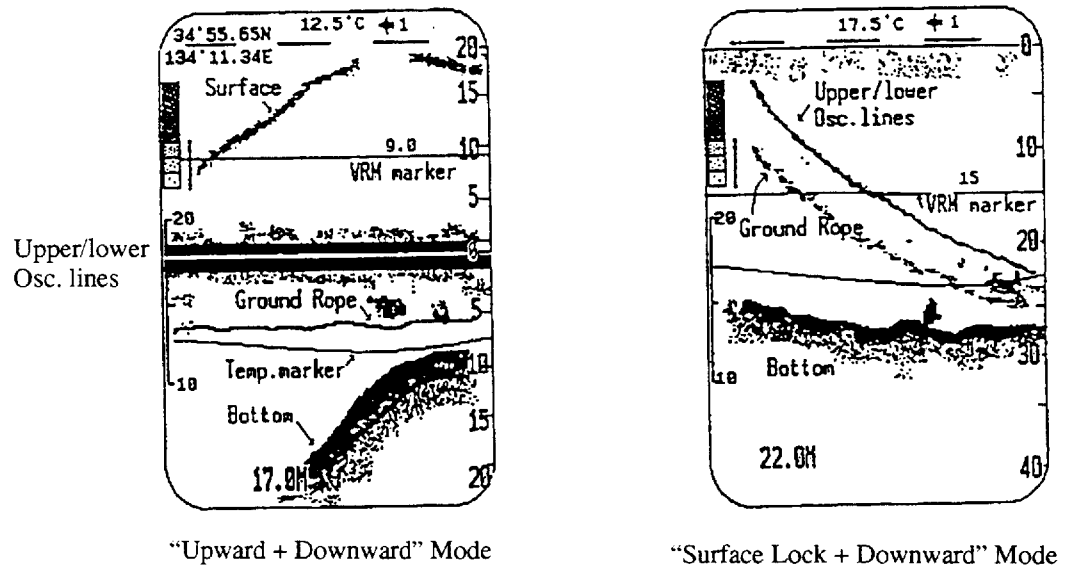
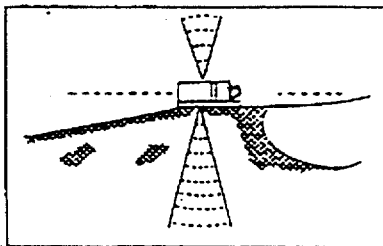

Fig. 2-3

### Transmission Line (TX Line)



Unlike the echo sounder, which shows ship's bottom, the transmission line shows the transmitter unit on the trawl. It is always displayed horizontally in the center of the screen in the "upward + downward" mode. In the true motion (TM) picture, since the sea surface is displayed by a straight line at the screen top, the transmission line position changes in accordance with the movement of the trawl, allowing intuitional monitoring of the net behavior.

### Seabed

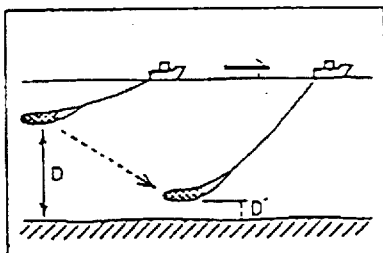

The seabed is normally displayed in reddish brown or red. In the downward sounding picture, since the transmission line is fixed horizontally on the screen even if the trawl net moves up and down, the actual contour of the seabed is not displayed. If, for example, the trawl descends (as in the left hand figure) over a flat seabed, the seabed is displayed as if it rises and approaches the transmission line.

In the true motion picture, the actual seabed shape is displayed.

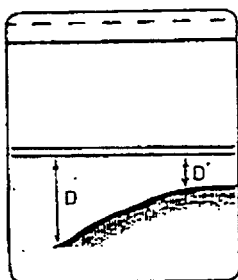

## Fish School

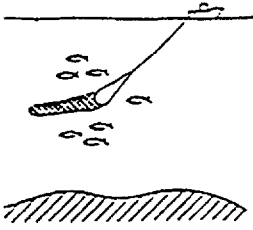

A fish school is displayed in a variety of colors depending on its size and density.

When the ground rope of the trawl is present on the screen, a fish school which appears between the transmission line and the ground rope can be considered to be entering the trawl.

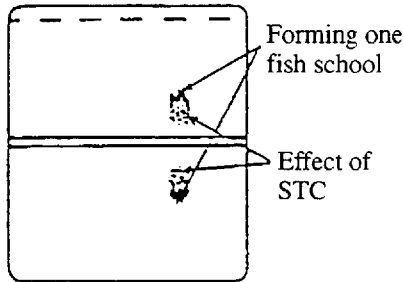

If the trawl passes through a fish school, the fish school will appear (with some discontinuity) above and below the transmission lines, as in the left hand figure. This discontinuity is due to the effect of the STC (Sensitivity Time Control), which suppresses the receiver gain in short ranges in order to reduce the tail of the transmission line. In other words, if two fish schools are displayed as in the left hand figure, they can be considered to be forming one fish school.

## Ground Rope

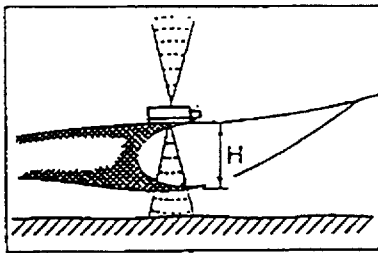

If the ground rope of the trawl is positioned in the coverage of the sounding beam it is displayed as a line almost parallel with the transmission line.

The interval between the transmission line and the ground rope is equivalent to the height of the net opening and therefore the interval is kept constant if the net is being properly towed. If it is unsteady, or if the ground rope rises suddenly, towards the transmission line, abnormal net behavior is likely, for example, the trawl is caught on a protuberance.

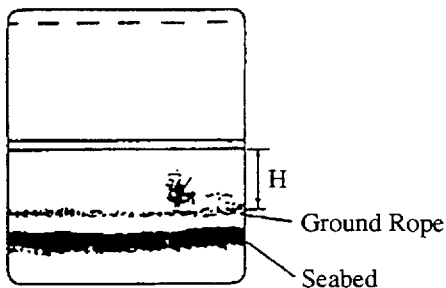

Another usage of the ground rope is as a reference to check whether or not the trawl is opening as designed, after the otter boards or the trawl have been replaced.

## Noise

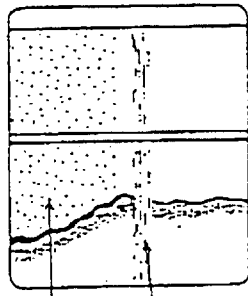

Noise resulting from  
log of synchroniza-  
tion

Noise produced by  
contaminated water

Noise is roughly classified into two categories: one caused by contaminated water and the other by lose of synchronization between the transmitter unit and towed (paravane) receiver. The former can be removed to a certain extent by the THRESHOLD control on the display unit, while the latter, the only way to remove it is to change the positions of the transmitter unit and paravane receiver so the transducers on both units face each other. The characteristic of the former as compared with the latter is that it appears for a comparatively extended period time with the fish school and seabed echoes displayed normally, while in the latter, seabed and fish school echoes randomly appear every time the picture advances. In other words, echoes themselves look like noise as they appear at random.

## Multiple Reflections

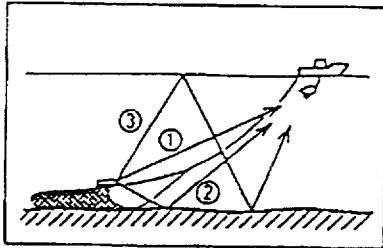

Sometimes, multi-path echoes are displayed as strong as or stronger than fish echoes.

The left hand figure illustrates why multi-path echoes are displayed. The multi-path echoes, which make observation of normal echoes difficult, are delayed sounding pulses. They usually appear between the TX line and seabed echo as faint traces representing the seabed shape. In most cases, they are displayed when there is a hard object (rock, marine ridge, etc.) giving good reflection of ultrasonic waves on the seabed between the transmitter unit and ship. If multi-path echoes severely interfere with observation of the picture, they should be reduced by changing the tilt angle of the paravane receiver or putting a float behind the transmitter unit.

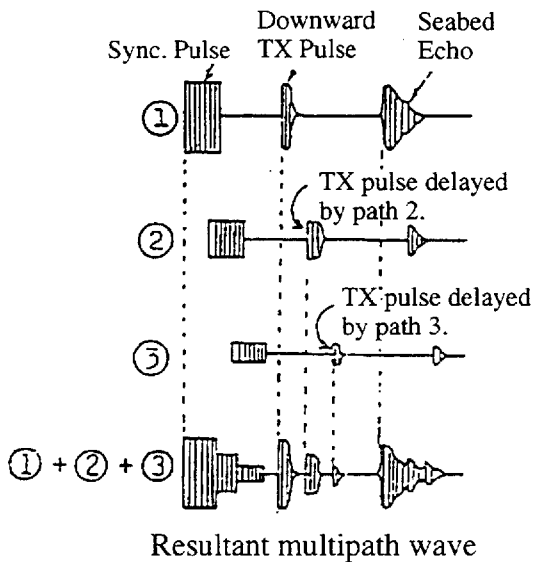



## 2-4. FISHING OPERATION AND PICTURE PRESENTATION

The figure below shows the relation between the trawl behavior and the picture presentation in the "upward + downward" mode during bottom trawling.

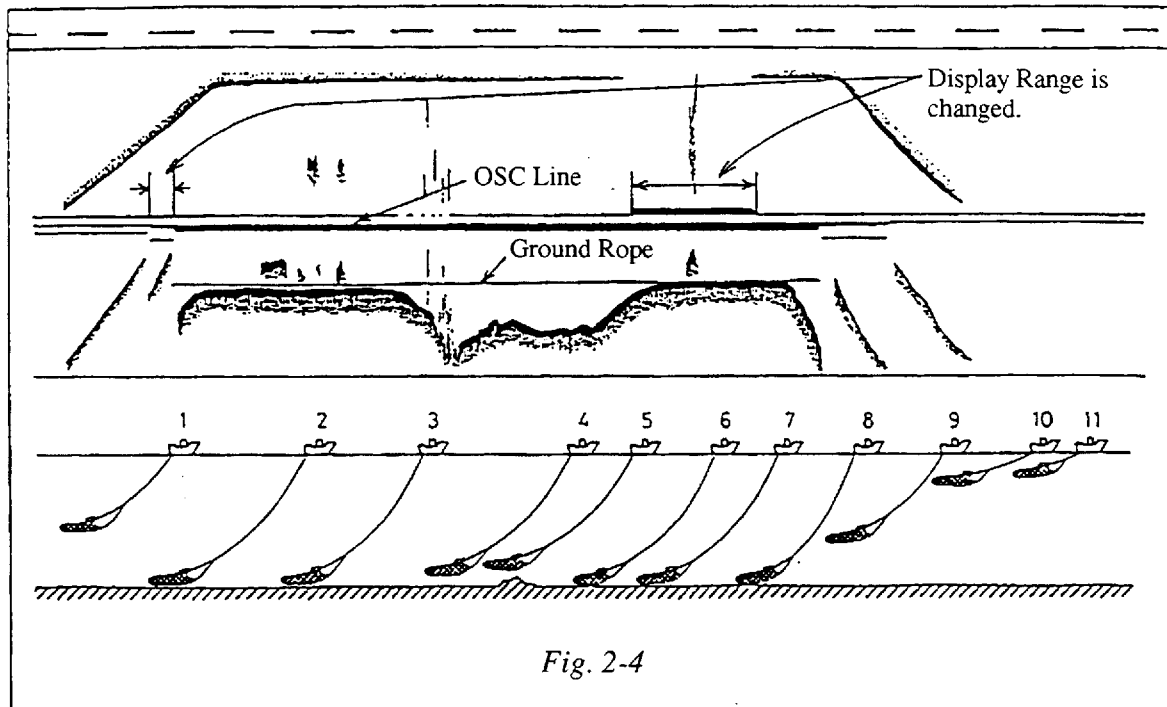

Fig. 2-4

1. The trawl is set into the water and begins descending. In the picture, the distance between the transmitter and the seabed gets shorter and shorter as if the seabed is rising toward the transmitter unit. On the other hand, the distance between the transmitter unit and the sea surface increases as if the sea surface is receding from the transmitter unit.

The range setting for the downward sounding picture has been changed twice for shorter ranges.

2. The trawl has settled on the seabed.
3. The trawl is being towed along the seabed. Fish entering the trawl are seen between the transmission line and the ground rope. Also, some fish schools above the trawl are seen on the upward sounding picture.

The ground rope is being kept at a constant distance from the transmitter unit; indicating that the trawl mouth is opening properly in the course of towing.

4. The ship has accelerated to clear a shoal. The trawl is jumping off the seabed and the seabed is displayed as if it has a sharp undulation though it actually does not.  
Since the signal from the transmitter unit is not properly received due to abnormal behavior of the trawl, some disturbance is also occurring at the beginning of the acceleration.
5. The trawl is passing over a shoal. The ground rope seen off the seabed indicates that the shoals have been cleared.
6. The trawl has settled on the seabed again.
7. The trawl is being towed along the seabed.
8. Hauling of the trawl has begun.
- 9,10. The trawl is being hauled. As the hauling proceeds, the seabed echoes are becoming distant and the sea surface echoes are getting nearer to the transmission line.
11. Hauling is complete.

# CHAPTER 3 OPERATION OF TRANSMITTER UNIT AND PARAVANE RECEIVER

## 3-1. MOUNTING DIRECTION OF TRANSMITTER UNIT

The transmitter unit contains three transducers and two sensors. See the figure below. Mount the transmitter unit onto the trawl so the signal transmitting transducer faces forward of the trawl.

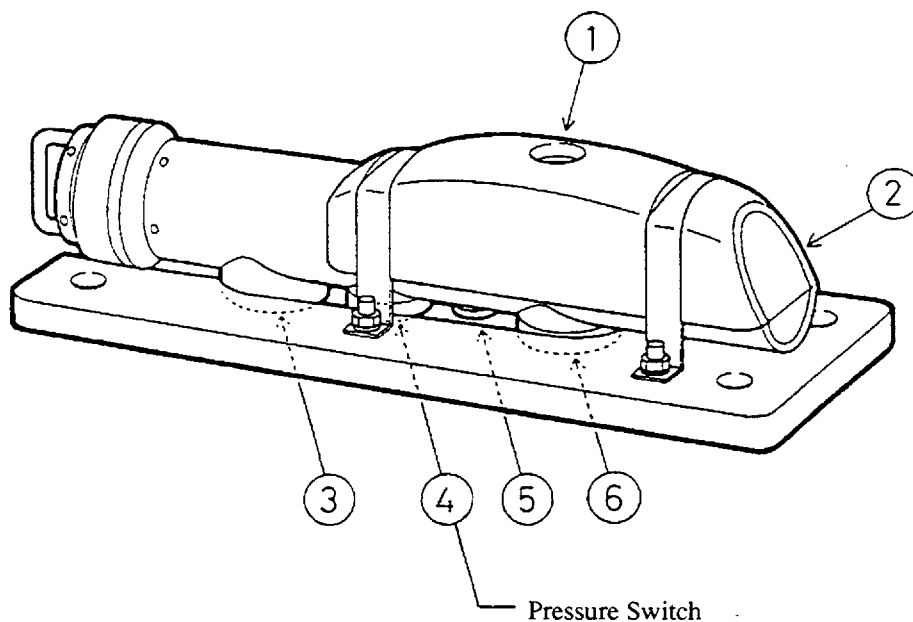

Fig. 3-1

Each transducer and sensor functions as described below.

- Upward & downward sounding transducers (①, ③):

Sounds fish school, bottom, etc.

- Signal Transmitting Transducer (②):

Sends detected information to the ship's receiver.

- Pressure/Temperature Sensor (⑤):

Detects net depth and temperature at net position.

- Catch Monitor Connector (⑥):

Connects with catch monitor.

## Relation between Transmitter and Receiver

- Signal transmitting transducer of the transmitter faces the paravane receiver.

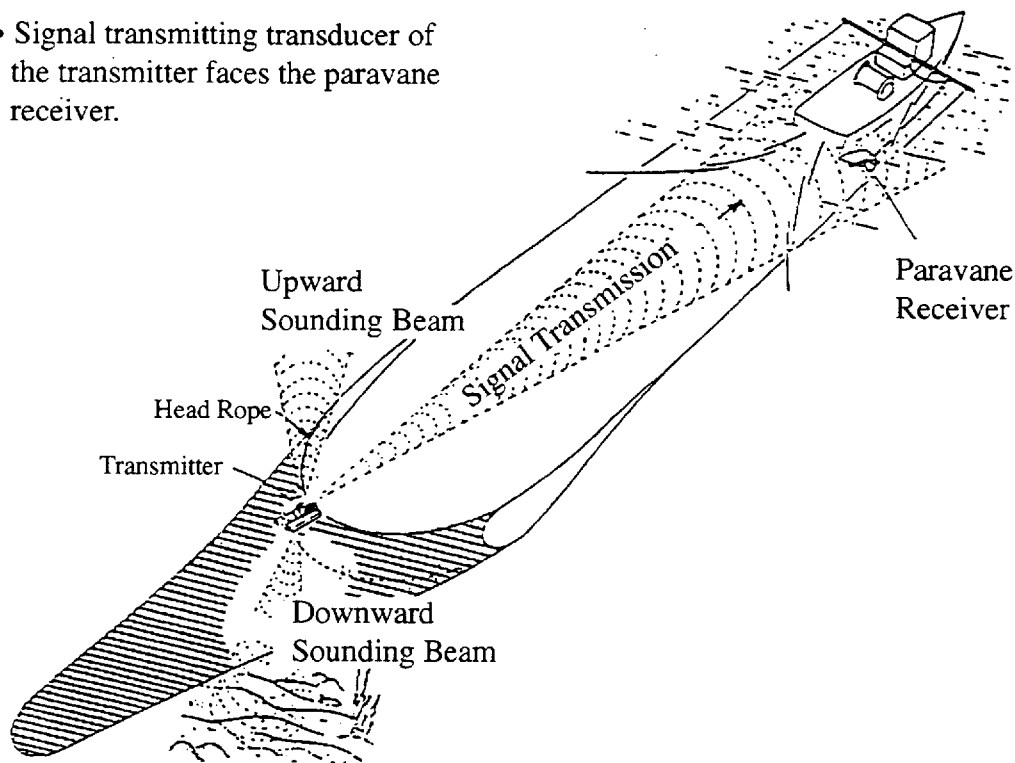

Fig. 3-2

## 3-2. MOUNTING TRANSMITTER UNIT ONTO THE TRAWL

Usually the transmitter unit is fixed either on the head rope of the trawl or on the belly just above the ground rope.

The advantage of the former position is that the transmitter unit is held horizontal almost throughout the towing operation and consequently a good, stable picture can be expected. Its disadvantage is that it is difficult to detect the ground rope, especially in bottom trawling since the ground rope in the bottom trawl becomes positioned farther back than the head rope. In mid-water and pelagic trawls, the ground rope usually becomes positioned below the head rope and hence. The ground rope is easily detected with the transmitter unit on the head rope.

If detection of the ground rope is necessary in bottom trawling, is fix the transmitter unit on the belly of the trawl so that the ground rope is placed in the downward sounding beam. In this position, however, since the net moves up and down more frequently than the head rope during operation, the net recorder picture tends to become unstable.

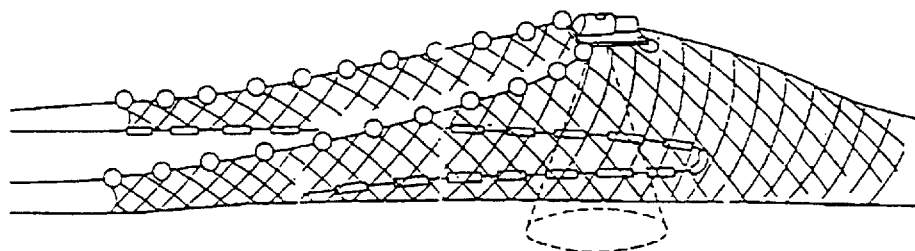
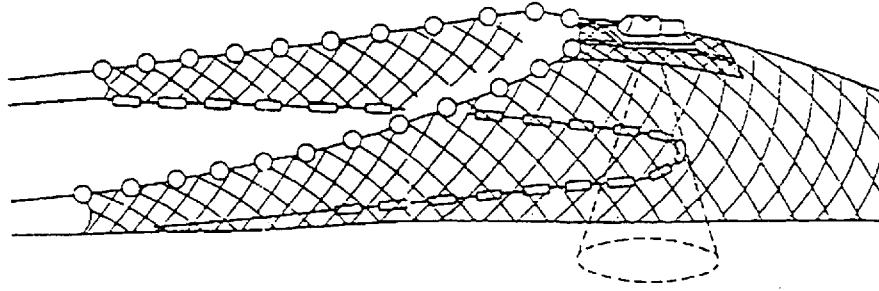
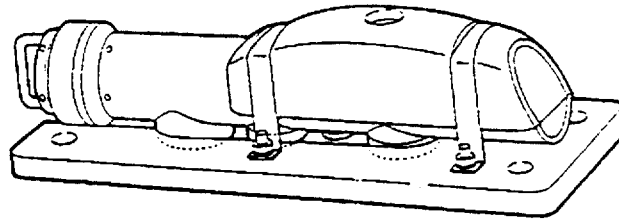

Fig. 3-3 Transmitter mounted on the head rope



*Fig. 3-4 Transmitter mounted on the belly*



*Fig. 3-5 Transmitter Unit*

When the transmitter unit is fitted on the head rope, fasten the front part of the fixing plate tightly at two points onto the head rope. The back part of the plate should be tied to the belly by supporting ropes which are long enough to allow the fixing plate to move up and down.

If the net mouth opening is irregular due to the weight of the transmitter unit, attach some floats to the fixing plate.

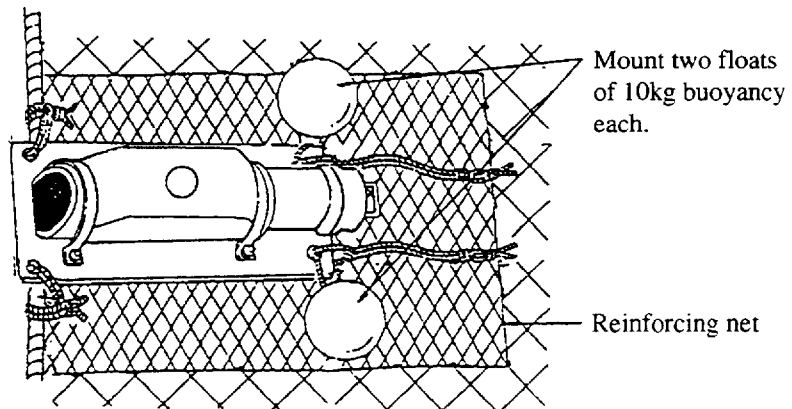

*Fig. 3-6 Samples of transmitter mounting*

When the transmitter unit is installed on the belly of the trawl just above the ground rope, run two reinforcing ropes perpendicular to the head rope and another two in parallel with the head rope. Fix the transmitter fixing plate tightly on the reinforcing ropes. The reinforcing ropes should be run through the meshes of the trawl. The back part of the fixing plate should be tied on the belly in the same manner as for mounting on the head rope.

When the transmitter is installed onto the belly of the trawl just above the ground rope, fit the reinforcing rope from the head rope so that the transmitter comes just above the ground rope. Fix the transmitter fixing plate tightly on the reinforcing rope with fastening ropes. The reinforcing rope should be put through the meshes of the trawl net. The back part of the fixing plate should be tied on the belly in the same manner as for mounting on the head rope.

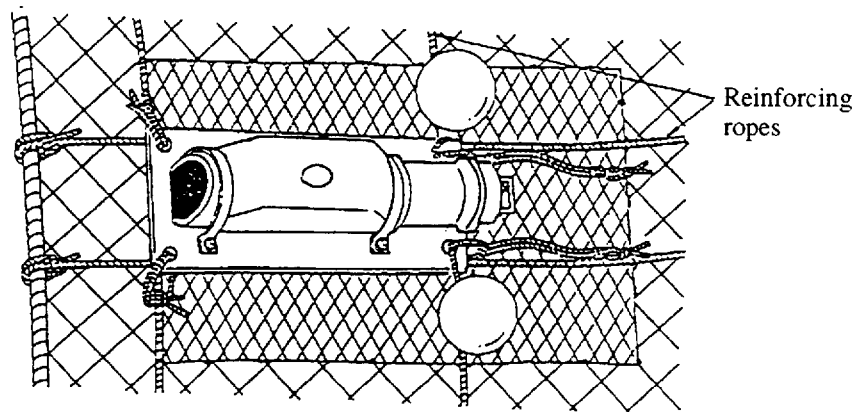

*Fig. 3-7*

In both of the above mountings, it should always be ensured that the transmitter unit is held horizontal during operation so that sounding beam hits the sea surface and seabed at right angle and also that there are no interfering objects in front of the transducers.

### 3-3. OPERATION OF TRANSMITTER UNIT

The transmitter unit is automatically switched on at a depth of approximately 10 meters by a pressure sensitive switch. It then starts to transmit signals with 28 degree beam width (in case of 50 kHz type) to the receiver at 25 degree elevation angle.

#### 75 kHz Transmitter

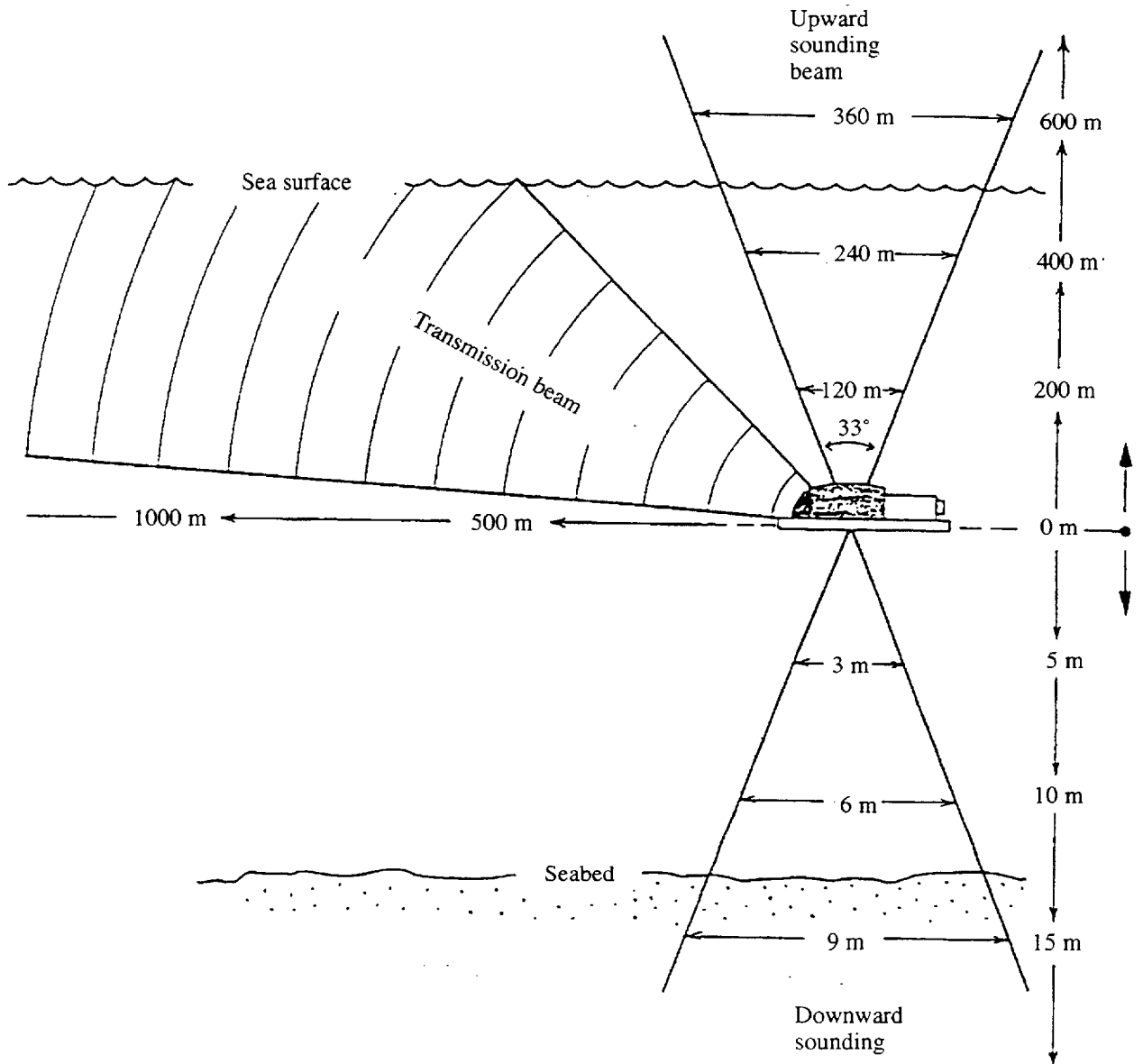

Fig. 3-8

## Gain Adjustment

The receiver gain control potentiometer is fitted behind the battery socket board as shown in Fig. 3-9. Though it has been properly adjusted at the factory, readjust the potentiometer when clear picture is not obtained. Note that too high gain setting will cause excessive noises.

Remove this screw and adjust the potentiometer inside.  
Turn it clockwise for higher gain setting.

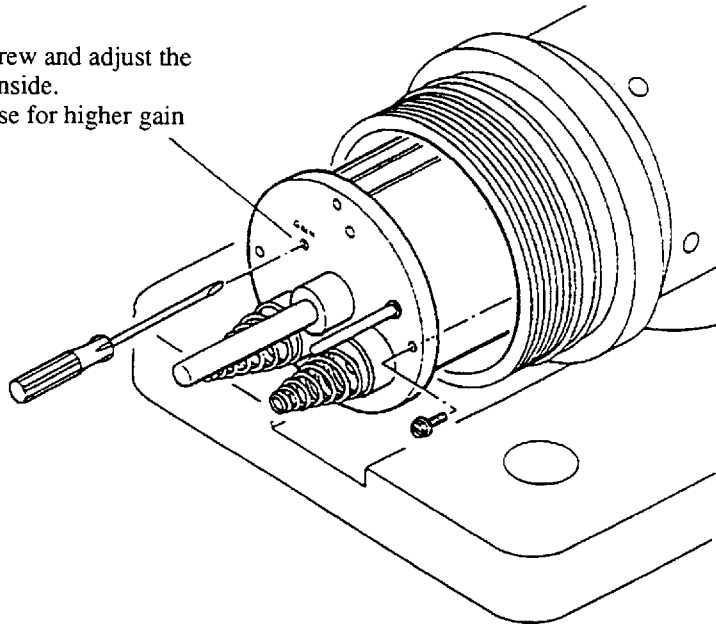

Fig. 3-9

When adjusting the gain, set GAIN control on the display front panel to "6-7" position and observe the picture on the CRT display.

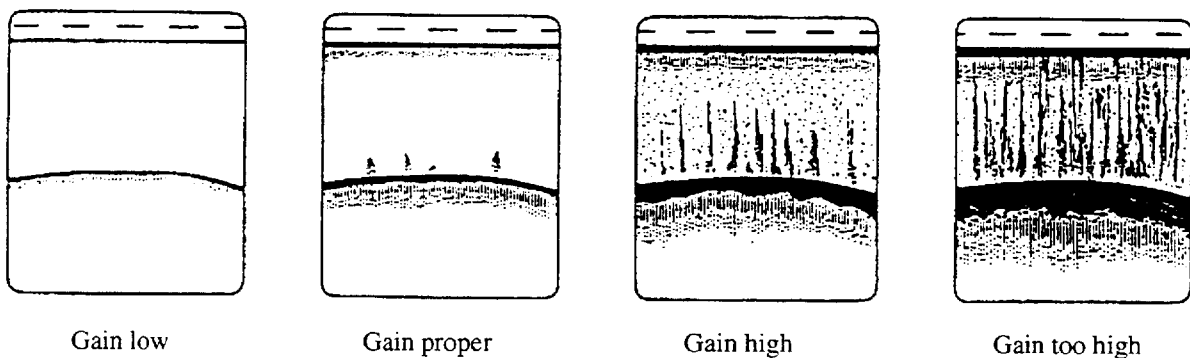

Fig. 3-10



## 3-4. PARAVANE RECEIVER

### Boom Installation

The paravane receiver is taken in tow by the boom to avoid interference due to bubbles or air foams caused by rotation of screw propeller. General installation is shown in Fig. 3-11.

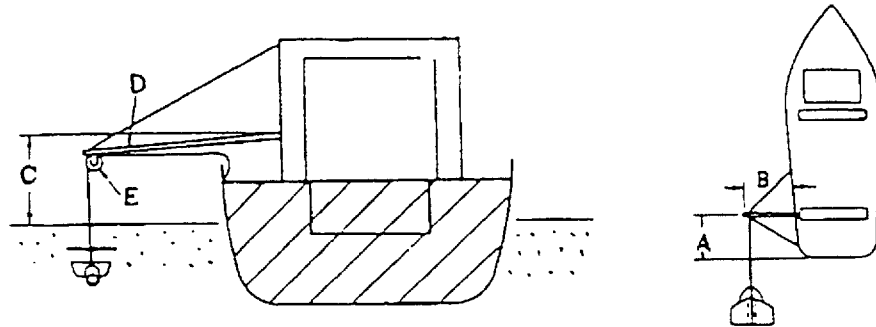

Fig. 3-11 Boom installation

The paravane receiver should be taken in tow as far behind the ship and as deep under the sea surface as possible.

| Symbol | Item          | General Description                                                                                                                           |
|--------|---------------|-----------------------------------------------------------------------------------------------------------------------------------------------|
| A      | Boom location | Less than 1/5 of ship's length from the stern.                                                                                                |
| B      | Boom length   | 4 m or more from the sideboard for 300 to 500 tonnage fishing boat.<br>8 m or more from the sideboard for more than 500 tonnage fishing boat. |
| C      | Boom height   | Less than 1/10 of ship's length.                                                                                                              |
| D      | Strength      | Withstand the load of 1000 kg.                                                                                                                |
| E      | Wooden block  | 150 mm or more in diameter, snatch type.                                                                                                      |

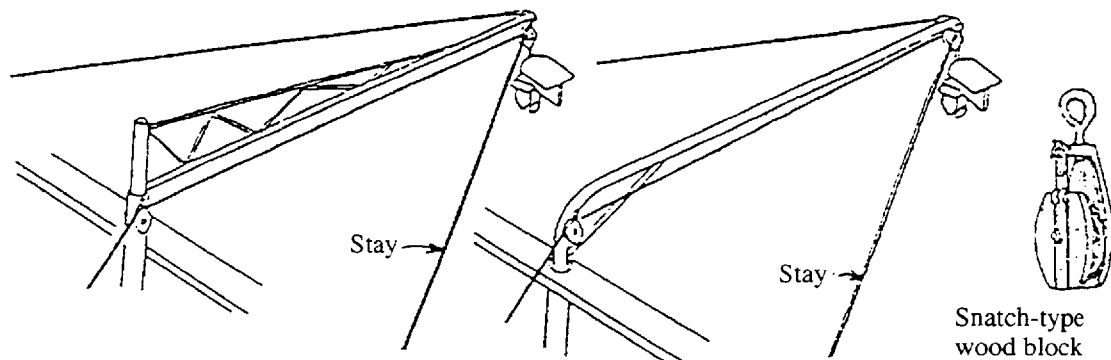

Fig. 3-12 Example of boom for small boat

## Wiring

The cabtyre cable is connected to the terminal board in the junction box, winch or transducer switch box. Color identification inside the cable is as follows.

White ) ..... Signal lines, no polarity  
Black )  
Red and Shield ..... Ground

## Operation

The paravane receiver should be put into the water slowly (after throwing the net) and retracted before the trawl is hauled up. To obtain stable receiving performance and avoid the effect of air bubbles, submerge the paravane receiver deeply and keep it away from the boat as much as possible. The figure below illustrates this condition.

The paravane receiver is normally towed by a 5 to 10 m boom which is extended from the stern side of the boat. This boom has wooden blocks at its ends through which the cabtyre cable is guided.

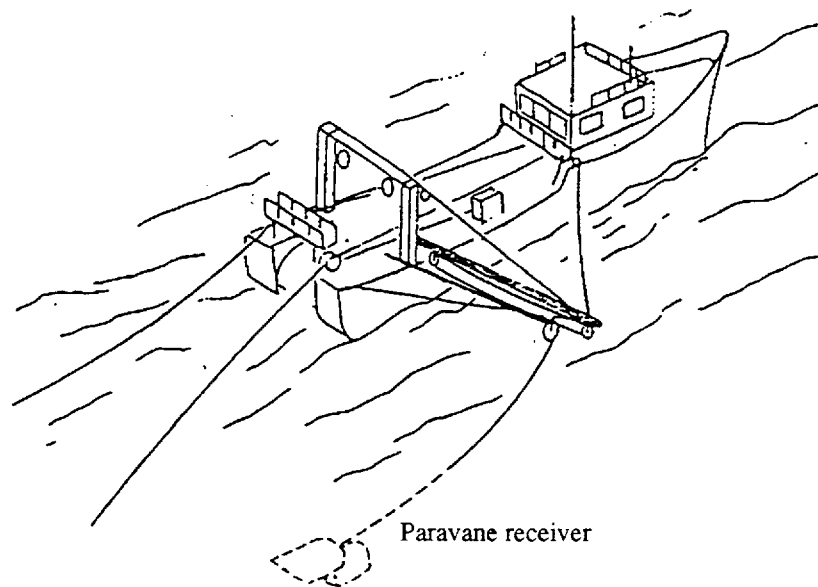

Fig. 3-13

### \*REMARKS ON OPERATION - - - - -

1. A white line is painted along the cabtyre cable monitor the line to watch for twisting of cable.
2. The cable should not become twisted unduly during use.
3. The insulation of the cabtyre cable may deteriorate if the outer sheath is damaged. Take care no to cross the cable with steel wires or guys aboard ship.
4. When bending the cabtyre cable, the bending diameter must not be less than 20 cm; sharp bending will break the conductors of the cable.
5. Be sure the paravane receiver will not be caught in the propeller when the boat goes port or starboard.

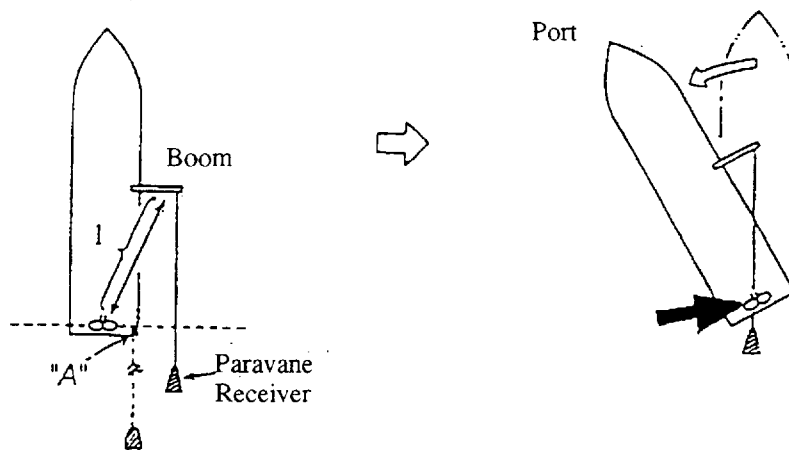

Fig. 3-14

Note: When towing the paravane without a boom, extend the cable from "A" to keep the cable away from the propeller.

5. Avoid propeller noise as much as possible.

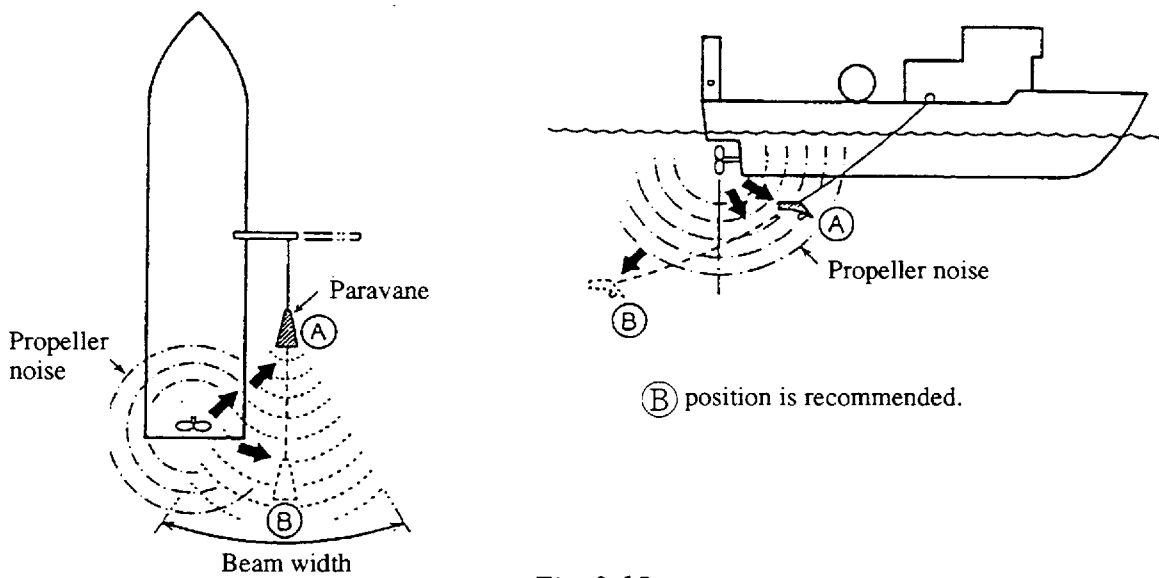

Fig. 3-15

6. Keep the paravane receiver away from the boat to avoid aerated water created by the propeller. Aerated water causes receiver position instability, resulting in poor reception.

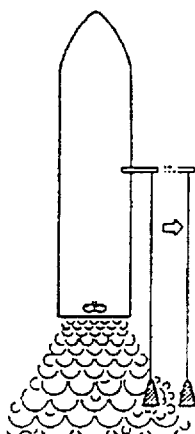
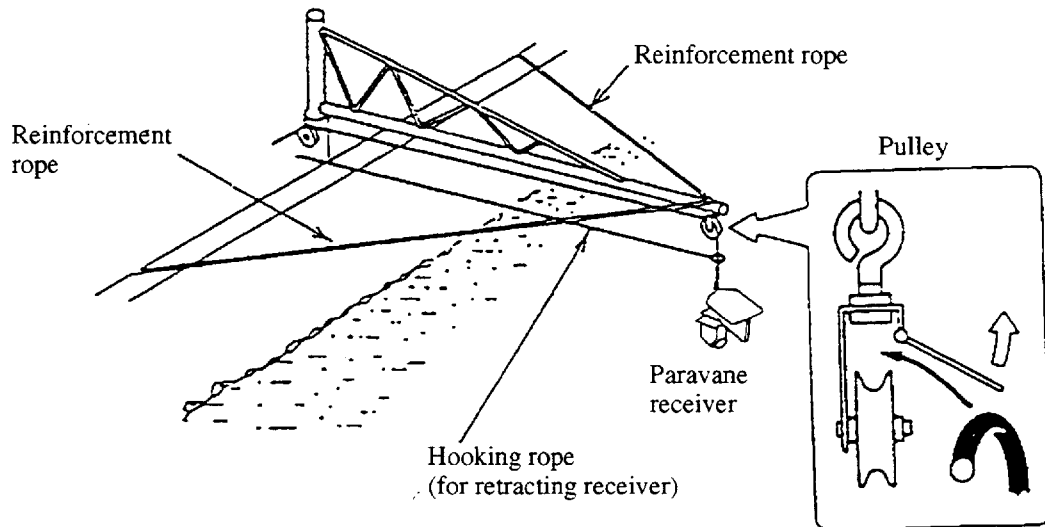

Fig. 3-16

### For Reference

- \* An iron pulley may damage the cable because it may rust. Use a wooden or stainless steel pulley to which the cable can be hooked easily from the open side.
- \* Reinforce the boom by installing ropes from the boom end to the ship's side-board.
- \* Retract the paravane receiver when not in use to prevent cable fatigue.



*Fig. 3-17*

## Tilt Angle Adjustment

The paravane receiver tilt angle can be adjusted in three steps: 15, 25 and 35 degrees from the horizon. Read out the suitable angle from Fig. 3-18, considering the depth of the trawl and length of the warp. Fig. 3-18 shows the beamwidth for 50 kHz receiver. In case of 33 and 40 kHz receivers, the beamwidth is 34 and 30 degrees respectively.

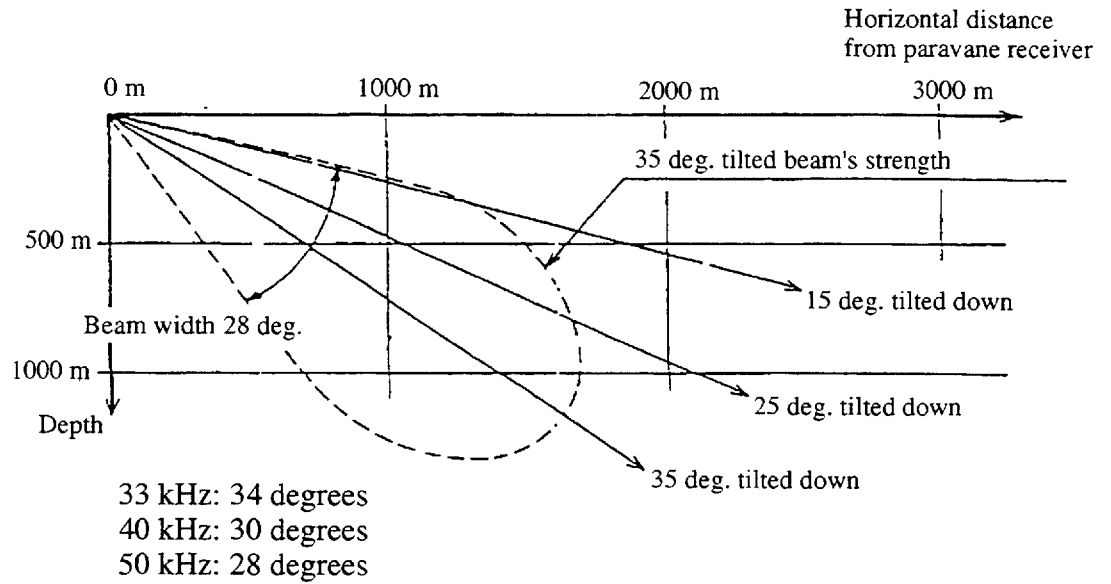

Fig. 3-18

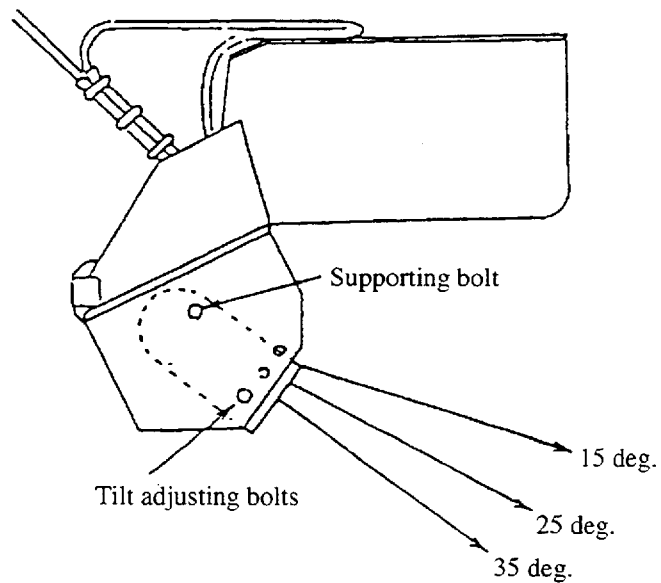

Fig. 3-19

## Cable Length

Generally a longer cable is better for signal reception. The cable length from the boom must be 20 meters or longer.

If the cable is too short, the paravane receiver will drift towards the propellers and the aerated water produced there or propeller noise will have an adverse effect on the receiving conditions.

With the cable long enough, the paravane receiver submerges, stabilizes, and positions itself 7 to 8 meters below the surface.

If an ocean current or tidal current pushes the net sideward it also pushes the paravane receiver in the same direction, thus the transmitter unit and the paravane receiver are kept in alignment as shown in Fig. 3-20.

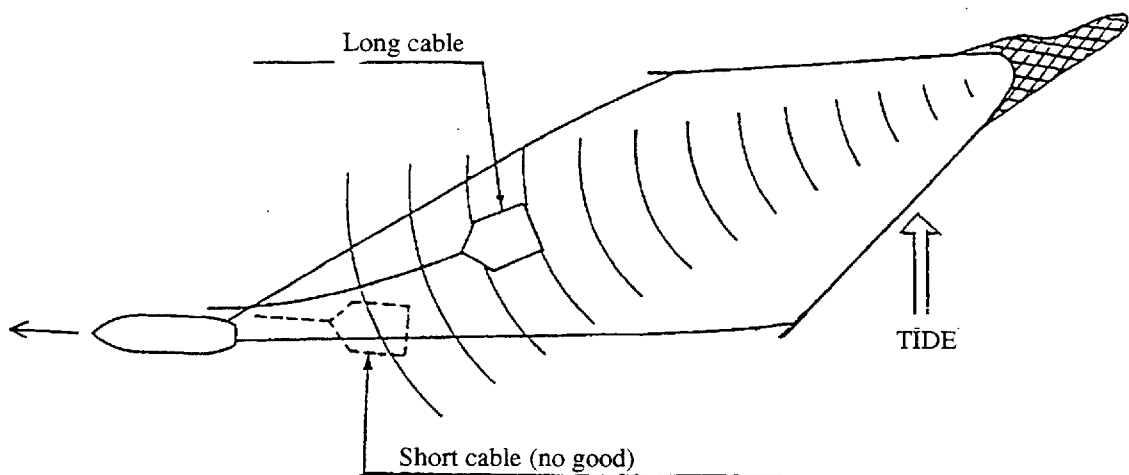

Fig. 3-20

## Balancing Block

The balancing block can be bolted on either side of the vertical plane of the paravane receiver. The correct position is the opposite side of paravane movement.

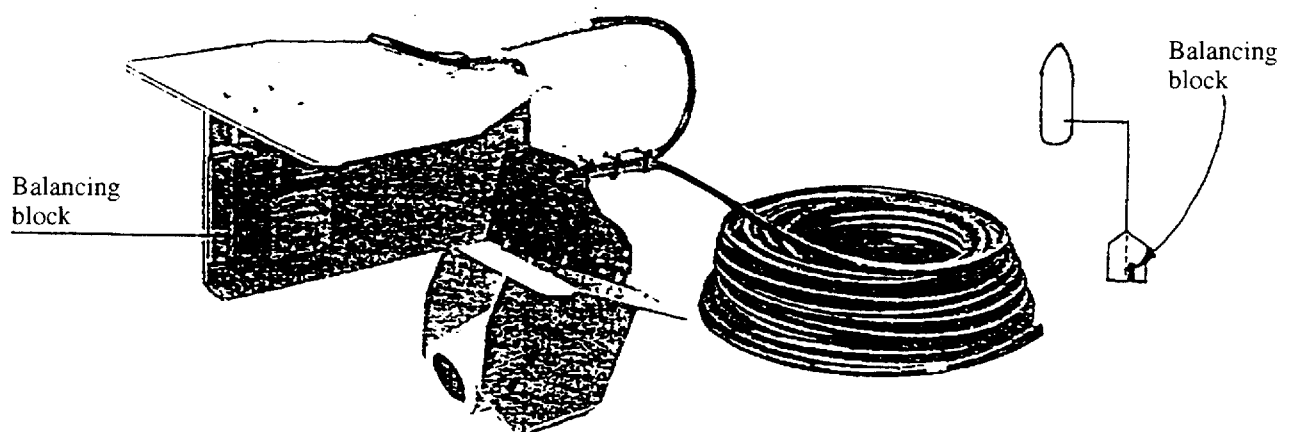

Fig. 3-21

### 3-5. SELECTION OF SOUNDING RANGE

The sounding range is set with DIP switch S1 on the CONT-B 01P5741 board. The switch is factory-set to 80 m for both the upward and downward ranges. To change the factory setting refer to the figure below.

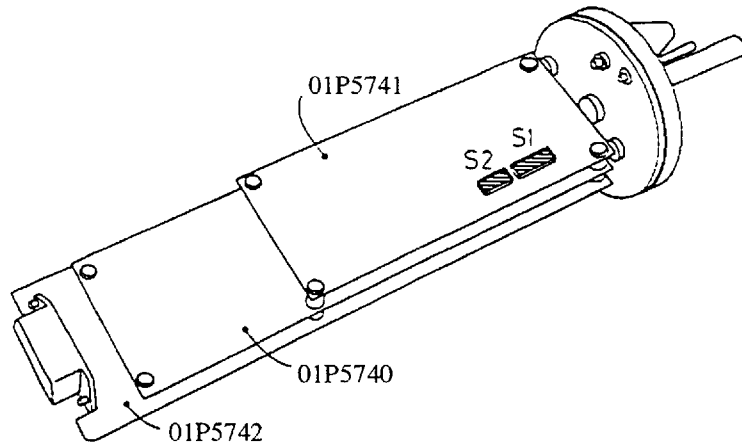
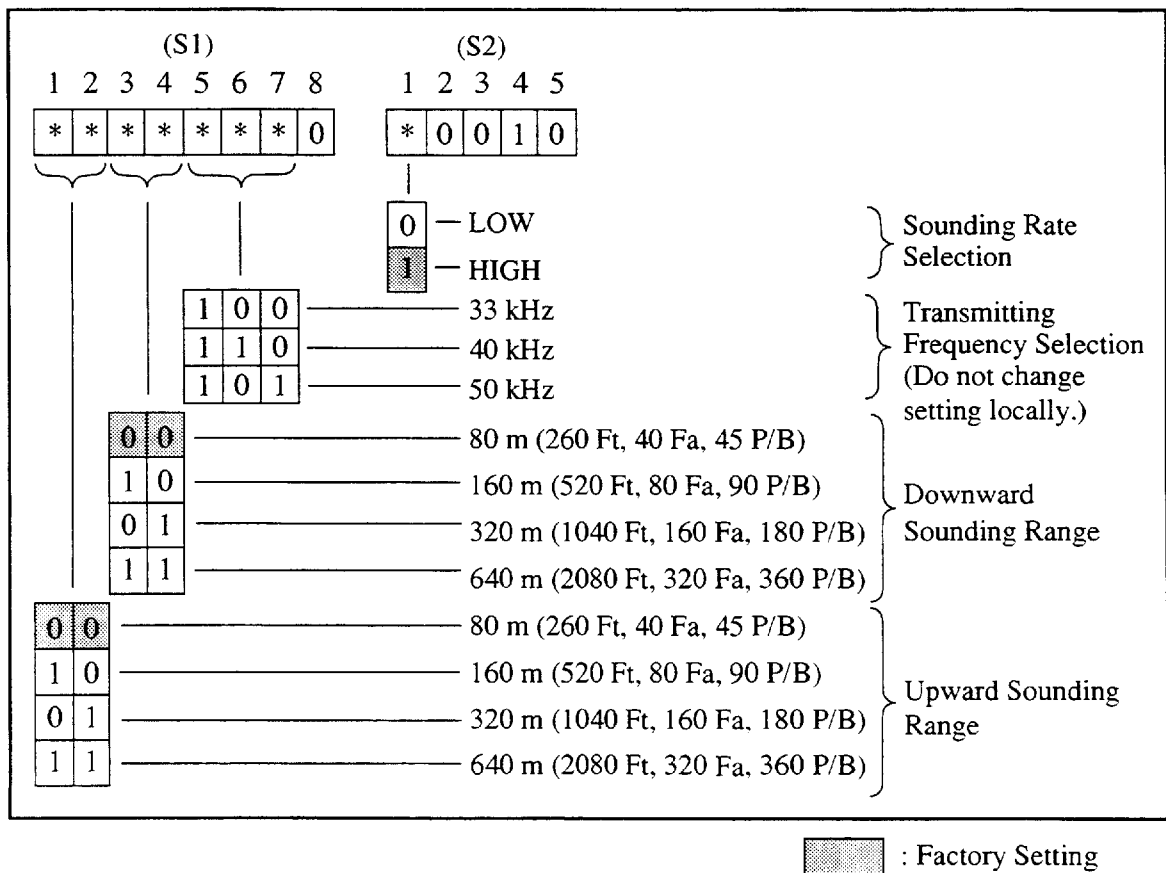

Fig. 3-22 S1, S2 location

#### S1, S2 DIP SWITCH SETTING in Normal Operation Mode



Note: The sounding range determines the maximum range for echo reception.

### 3-6. SELECTION OF SOUNDING RATE

The sounding rate is set with S2 (#1) DIP switch on the CONT-B 01P5741 board. The switch is factory-set to "HIGH" (190 times/min).

When "LOW" is selected, the rate is down to 1/3 approximately. See table below.

The relation between sounding rates and Upward/Downward ranges is shown below.

| RANGE (Up/Down) |      | 80/80 | 160/80 | 160/160 | 320/80 | 320/160 | 320/320 | 640/80 | 640/160 | 640/320 | 640/640 |
|-----------------|------|-------|--------|---------|--------|---------|---------|--------|---------|---------|---------|
| Sounding Rate   | LOW  | 63    | 59     | 55      | 51     | 48      | 43      | 37     | 36      | 33      | 27      |
|                 | HIGH | 190   | 177    | 165     | 154    | 145     | 130     | 113    | 108     | 99      | 81      |

**For reference**

The higher the sounding rate of the transmitter unit becomes, the more information you will get from the picture. Let's take the sounding rates of 63 pulses/min. and 190 pulses/min. as examples for a transducer beamwidth of 33° and the ship running at 4 knots. At the rate of 63 pulses/min., a sounding pulse is emitted every 2.0 meters traveled by the ship and, in 190 pulses/min., every 0.6 meter of travel, as in Fig. 3-23. A single fish located at a 6 m depth is hit twice by the pulse in the former, but at least six times in the latter.

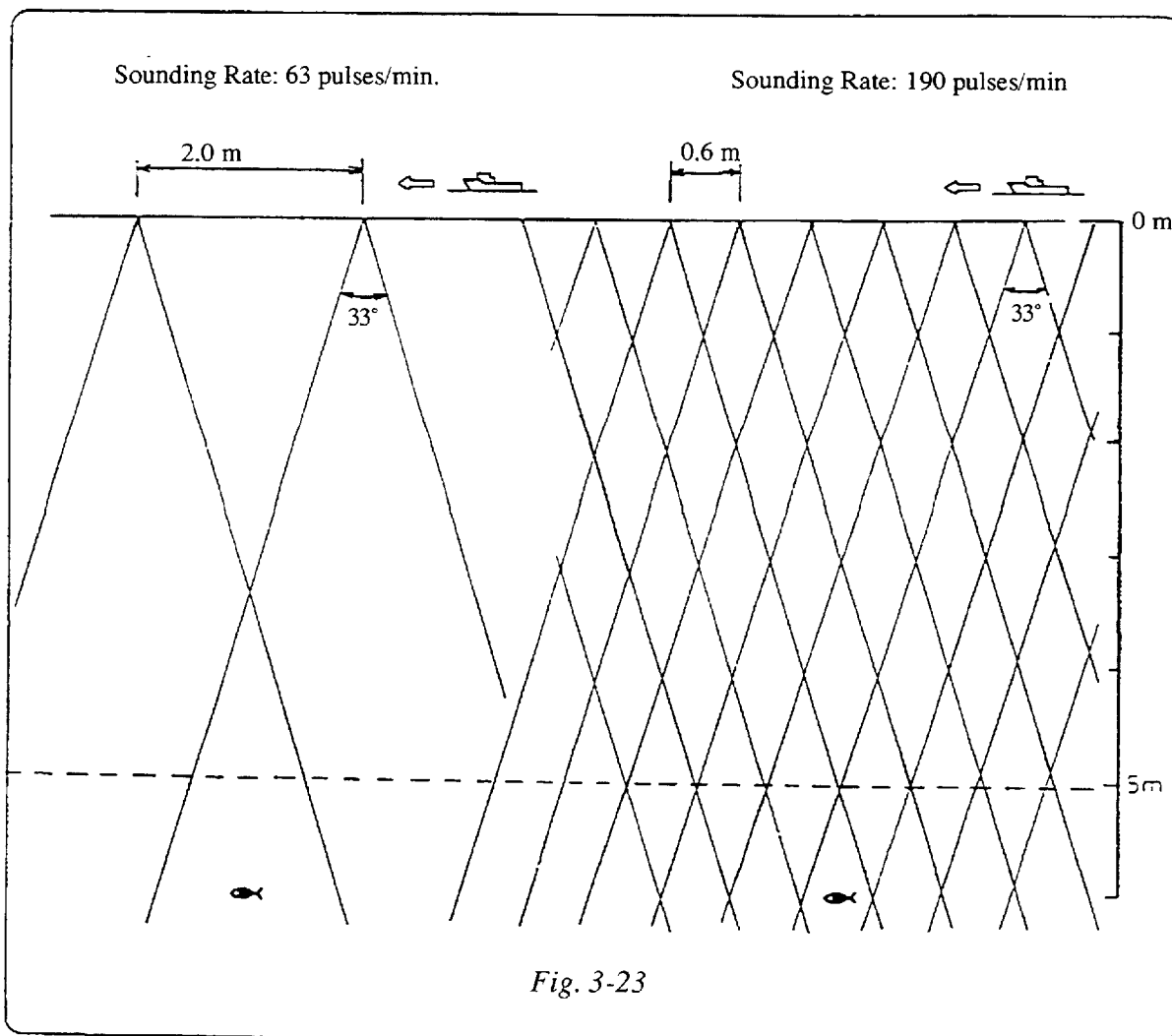

Fig. 3-23



## 3-7. BATTERY CHARGER BC-8 (Option)

### Charging Procedures

1. Place the battery pack into the charger, paying attention to the alignment marks.
2. Set charging time on the TIMER to 15 hours. USE the outer scale for 50 Hz ship's mains and the inner scale for 60 Hz
3. Connect the charger to the power supply. Press the START button, and the POWER and CHARGE lamps will light.
4. When charging is complete, both lamps will go off.
5. Pull out the power plug of the charger when it is not in use.

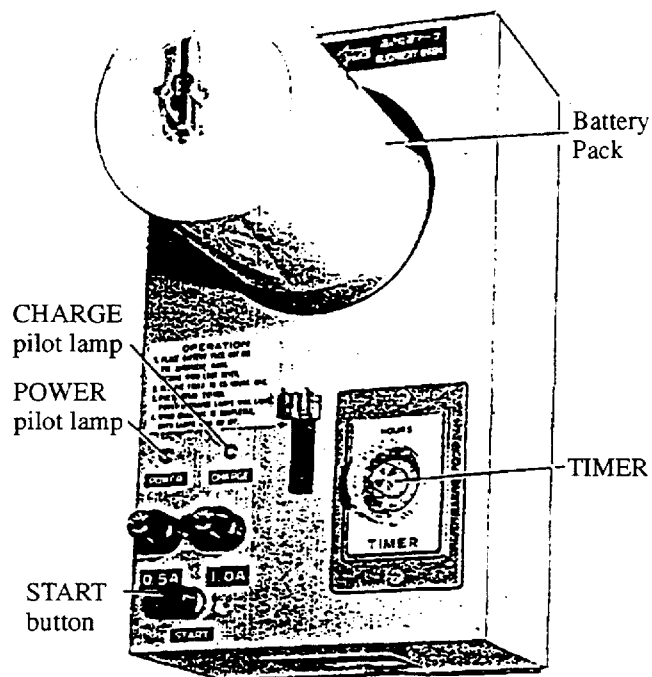

Fig. 3-24

### Notes:

1. When charging is completed, the battery voltage is approx. 12.5 V.
2. The battery can usually be used for more than 300 cycles of charge/recharge under normal use.
3. 30% of the battery power will be dissipated through self-discharging when it is unused and stored at an ambient temperature of 25 degrees for one month. Charge five hours in this case before operation.
4. It is recommended that battery is charged in a room temperature of 20 to 25 degrees.

## 3-8. REPLACEMENT OF DRY CELLS

Low supply voltage reduces the transmission range. Replace the alkali dry cells when supply voltage is low.

### Procedure

1. Remove the end-cover of the transmitter housing with the C-spanner supplied.
2. Take out the dry cell case and replace the dry cells.
3. Check that there is no dirt or no corrosion on the spring contacts for the dry cells. Confirm that O-ring is properly seated on the groove and well greased. Lubricate threads with grease, if necessary.
4. Put the dry cell case into the transmitter, referring to the alignment marks for correct engagement. See Fig. 3-25.
5. Screw in the end-cover to the transmitter by hand, and then secure it with the C-spanner to the limit for perfect watertightness. (When the end cover is completely tightened it cannot be advanced further.)

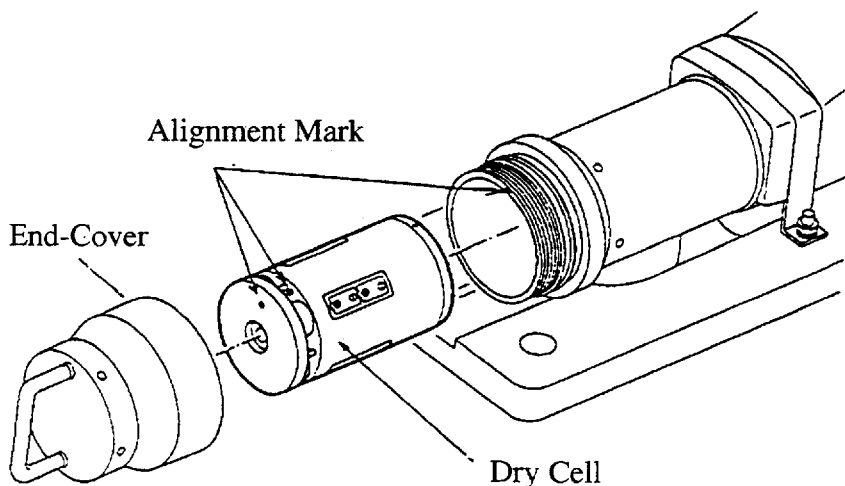

Fig. 3-25

### CAUTION

The battery in the transmitter unit may leak or explode if mishandled, which can result in personal injury. Care for the battery as follows:

- Do not dispose of the battery in fire or store it in a hot place.
- Do not short battery terminals.
- Use only the specified charger to change the Ni-cd battery.
- Do not disassemble or modify the battery or solder battery terminals.
- Do not use the battery in other equipment; it is strictly for use with the net recorder.
- The alkaline in the battery can cause loss of eyesight. If the alkaline contacts eyes, flush immediately with water and contact a physician.

# CHAPTER 4 MAINTENANCE

To ensure maximum performance of the equipment for many years, periodic check and maintenance is indispensable.

## 4-1. TRANSMITTER UNIT

### O-rings Check

The O-rings in the transmitter unit should be kept clean and lubricated with grease for complete watertightness. Everytime you open the lid to replace the battery cells, check the following items before replacing the housing lid.

- \* Check O-ring for cleanliness.
- \* Check the O-ring for physical damage.
- \* Confirm that the O-ring is properly seated in the groove and well greased.
- \* Confirm that threads are well greased.

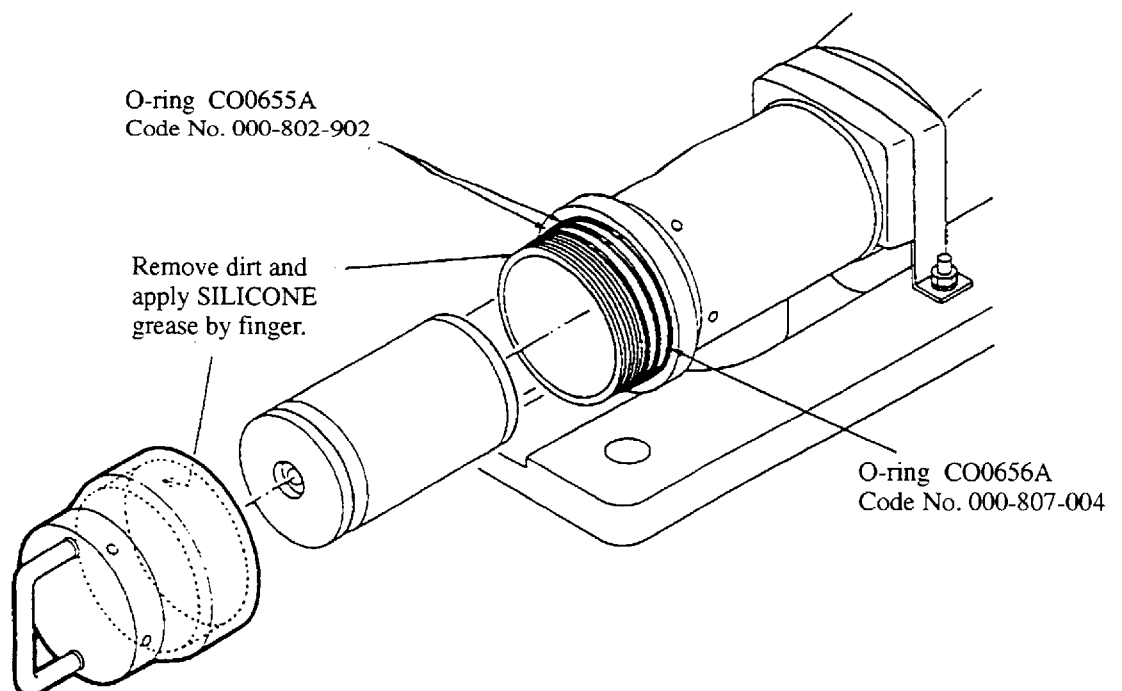
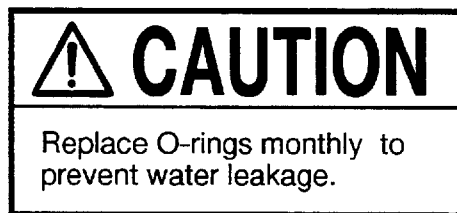

Fig. 4-1

## Function Check

Check function as shown in paragraph 4-4 "Testing Transmitter in Air". If your finger cannot feel any pulse from the transducers in the transmitter unit, dry cells may have discharged. Replace them referring to the page 3-16.

If you are using a rechargeable battery pack (optional supply), follow the check procedures of battery pack below.

### Battery Pack Check

Battery pack contains 8 pcs. of 3500 mA<sub>H</sub> Ni-Cd batteries connected in series. Since the terminal voltage of dry cell pack after full charge is 12.5 VDC approx. (it drops to 9.6 V after use for a while and keeps this voltage until most of energy is taken out), "full charge" is known by measuring the terminal voltage.

If multimeter reads less than 9.6 VDC after charge, one or some of the batteries in the pack may have discharged. In this case, replace of all the batteries.

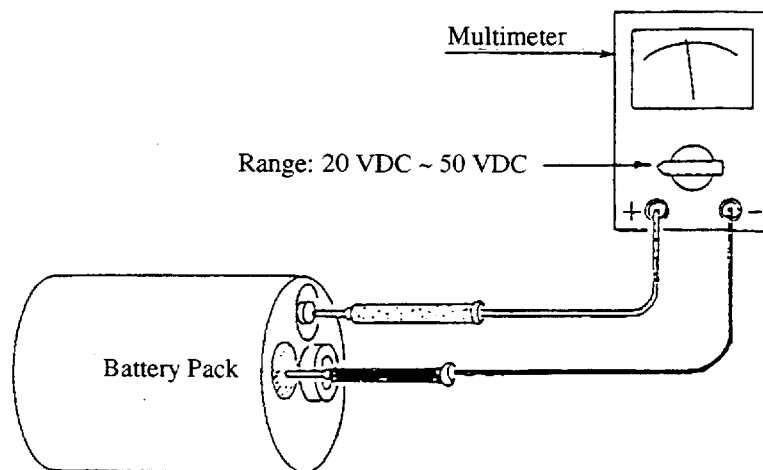
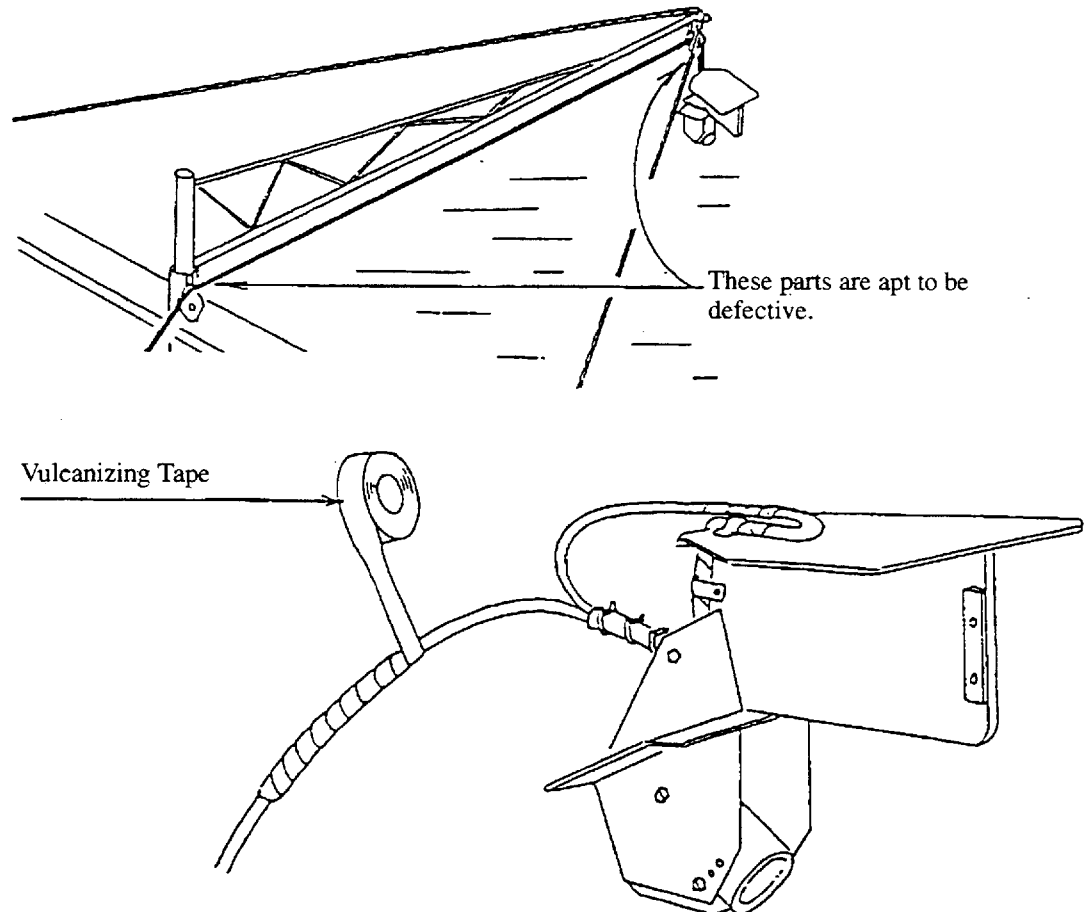

*Fig. 4-2*

## 4-2. CHECK OF PARAVANE RECEIVER CABLE

Check the receiver cable at least once a week for damage to its outer sheath; cable damage reduces sensitivity.

If damaged, remove any dirt and wrap damaged part with vulcanizing tape.



*Fig. 4-3*

Note: Retract the paravane receiver when not in use to prevent cable fatigue.

## 4-3. REPLACEMENT OF TRANSDUCER ON PARAVANE RECEIVER

The transducer of the paravane receiver is jointed with the cabtyre cable by a connector in the transducer case. When the cable is damaged or when the signal transmission frequency is altered, the cable or transducer should be replaced, referring to the instructions below.

The transducer case is constructed watertight with an O-ring and other materials. Ensure watertightness after the replacement.

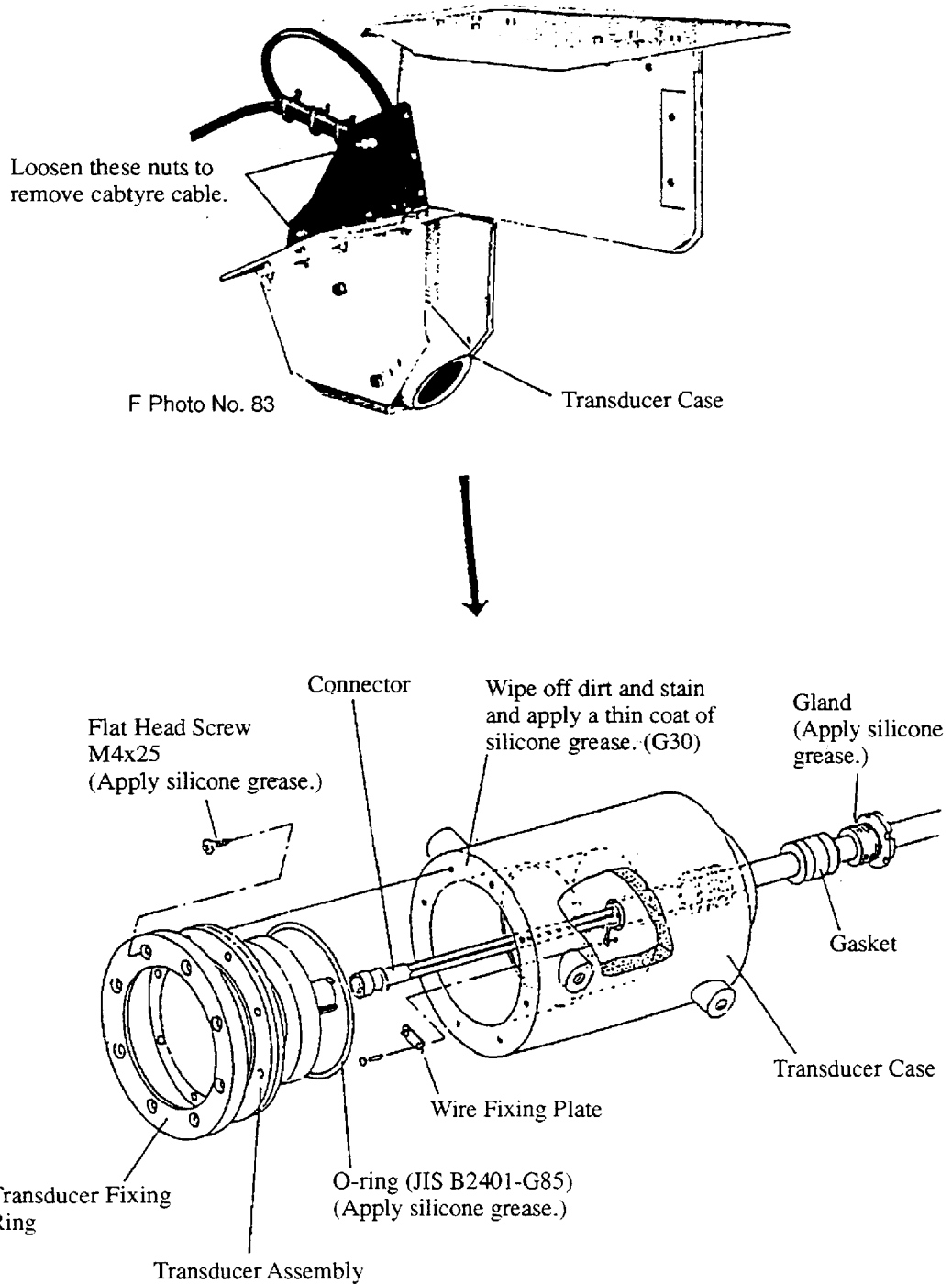

Fig. 4-4

## Replacement of Transducer

1. Place the paravane receiver upside down so that the transducer faces upward.
2. Unscrew M4x25 flat head screws and remove the transducer fixing ring.
3. Take out the transducer and disassemble the connector.
4. Apply silicone grease on the O-ring (JISB2401-G85) and set it to the new transducer.
5. Wipe off dirt and stain on the front face of the transducer case and apply a thin coat of the silicone grease.
6. Mate the connector.
7. Place the transducer fixing ring in position and fix it by flat head screws.

Note: The flat head screws should be tightened securely by using both hands.

## Replacement of Cabtyre Cable

1. Place the paravane receiver upside down so that the transducer faces upward.
2. Unscrew M4x25 flat head screws and remove the transducer fixing ring.
3. Take out the transducer and disconnect the connector.
4. Loosen the gland.
5. One of the three conductors of the cabtyre cable is fixed by the wire fixing plate located inside the transducer case. Remove the wire fixing plate by using a phillips head screwdriver.
6. Pull out the cabtyre cable.
7. Pass the new cabtyre cable (with connector) into the transducer case and fix the unused conductor with the wire fixing plate.
8. Put back the gasket and the gland. (Coat threads on gland with silicone grease).
9. Mate the connector to the transducer and assemble.

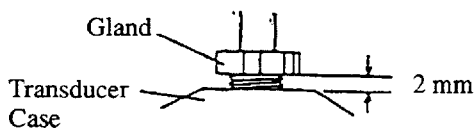

Note: Tighten the gland until the gap between the transducer case and the gland becomes 2 mm.

Fig. 4-5

The O-ring (JISB2401-G85) should be replaced whenever the transducer case is disassembled.

## 4-4. TESTING TRANSMITTER IN AIR

The transmitter can be checked in air for testing or in the water shallower than 10 m

1. Arrange all units as shown below.

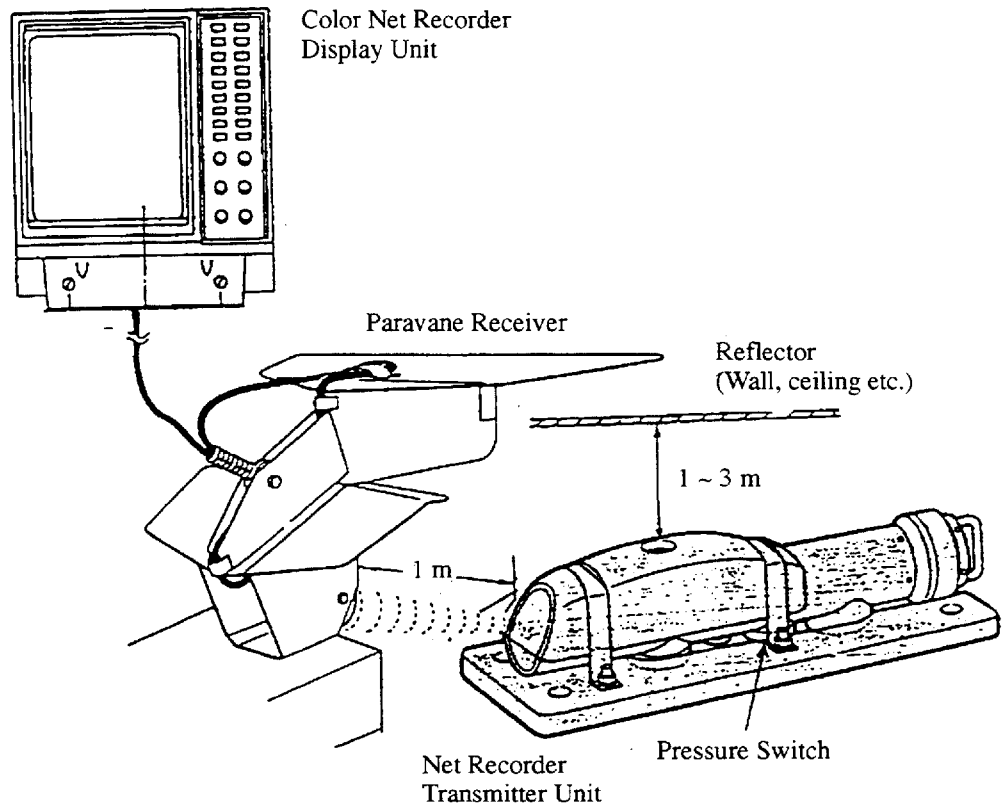

Note:

- 1) Stop the transmission within 5 minutes to prevent transducer damage.
- 2) The unit of 10 W TX output can not be checked in air. The test can be done by one of two ways:
  - Reduce the output power down to 2.4 W and follow the procedures on this page.
  - Place the TX unit in the water tank or bucket to check the operation. If signal transmitting transducer is working, you can hear the TX sound and sense the pressure on the transducer surface by hand. The display check can not be done using this method.

*Fig. 4-6*

2. Turn the screw of the pressure switch (test switch) 1.5 turns clockwise with a screwdriver to turn on the transmitter unit.
3. Placing your finger on the radiating face, you should be able to unit is transmitting normally.



4. Turn on the display unit.

If all units (transmitter, receiver + cable and display unit) are operating satisfactorily, some echoes are displayed on the screen. Note that the depth of echoes is four times greater than their actual depth since sound velocity in air is  $1/4$  of the one in water.

5. If the operation check results are satisfactory, turn the test switch fully counterclockwise.

### Test in air without Paravane Receiver

Make the test cable and place the loop near the signal transmitting transducer as shown in figure. The signal from the transducer can be picked up through the loop by the electromagnetic induction.

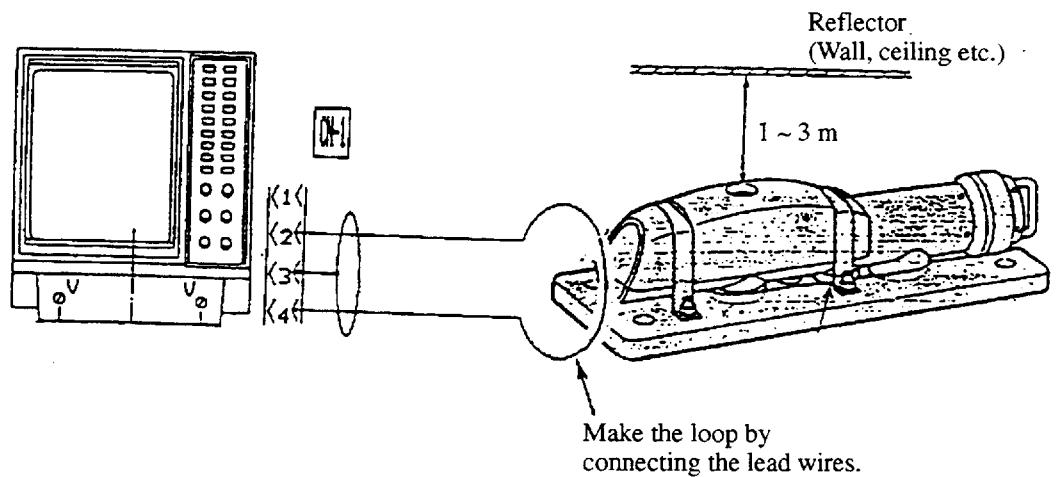

Fig. 4-7

# CHAPTER 5 CHANGE OF INTERNAL SETTINGS IN DISPLAY UNIT (for technicians)

Change/confirm the internal setting at installation according to user's preference, combined navigational equipment/optional sensor, etc.

**\* Change internal settings when;**

- 1) Receiving the ship's position data in NMEA data format.
- 2) Receiving the speed/temperature data from a navigational equipment.
- 3) Changing the display specification.

**\* Procedures**

- 1) Turn off the power by pressing the PWR and OFF keys together.
- 2) Remove the display cover by loosening the fixing screws.
- 3) Change the settings of DIP switches S1, S2 and S3 on the DISP board 01P5726 referring to the figure/table below.

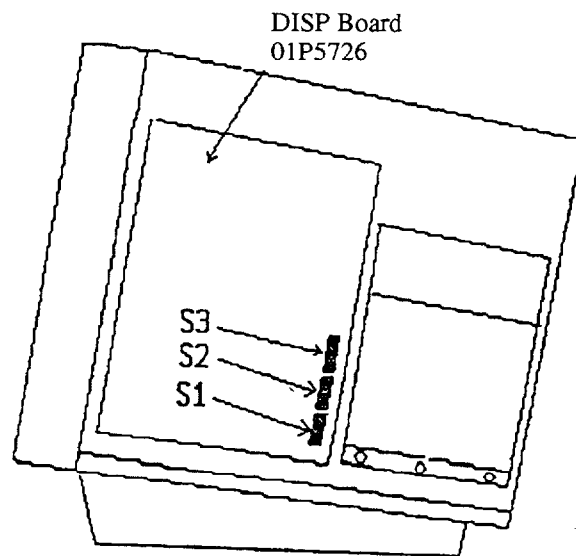

Fig. 5-1

**[S1 SETTINGS] --- For Display items**

| No. | ITEMS             |            | SETTING/CONTENTS |         |     |    |     |          |     |     |
|-----|-------------------|------------|------------------|---------|-----|----|-----|----------|-----|-----|
|     |                   |            | ON               | M       | OFF | FT | ON  | FA       | OFF | P/B |
| 1   | Range Unit        | RANGE UNIT | ON               | M       | OFF | FT | ON  | FA       | OFF | P/B |
| 2   |                   |            | ON               |         | ON  |    | OFF |          |     |     |
| 3   | Data Format       | NAVS       | ON               | CIF     |     |    | OFF | NMEA     |     |     |
| 4   | Memory Back Up    | BACK UP    | ON               | On      |     |    | OFF | Off      |     |     |
| 5   | Menu Language     | CHR        | ON               | English |     |    | OFF | Japanese |     |     |
| 6   | MT-12 OPERATION*1 | PLAY       | ON               | TAPE    |     |    | OFF | PANEL    |     |     |
| 7   | Temperature Unit  | TEMP       | ON               | °C      |     |    | OFF | °F       |     |     |
| 8   | Operating Mode    | MODE       | ON               | Normal  |     |    | OFF | Test     |     |     |

\*1: This setting enables/disables the gain/clutter controls when playing back picture from picture recorder MT-12.

“ON” : Gain/clutter controls are disabled. The recorded picture is played back as it is.

“OFF” : Gain /clutter controls are enabled. The recorded picture can be gain/clutter controlled.

**[S2 SETTINGS]** --- For Synchronizing with Transmitter Unit

| No. | ITEMS                     |           | SETTING/CONTENTS |        |     |        |     |       |     |       |
|-----|---------------------------|-----------|------------------|--------|-----|--------|-----|-------|-----|-------|
| 1   | Not used                  |           |                  |        |     |        |     |       |     |       |
| 2   |                           |           |                  |        |     |        |     |       |     |       |
| 3   | Pressure Sensor Max Depth | XMTR TYPE | ON               | 2000 m | OFF | 1000 m | ON  | 500 m |     |       |
| 4   |                           |           | OFF              |        | ON  |        | ON  |       |     |       |
| 5   | Downward Sounding Range   | DN RANGE  | ON               | 80 m   | OFF | 160 m  | ON  | 320 m | OFF | 640 m |
| 6   |                           |           | ON               |        | ON  |        | OFF |       | OFF |       |
| 7   | Upward Sounding Range     | UP RANGE  | ON               | 80 m   | OFF | 160 m  | ON  | 320 m | OFF | 640 m |
| 8   |                           |           | ON               |        | ON  |        | OFF |       | OFF |       |

**[S3 SETTINGS]** --- For Synch Code detection (Threshold)

| No. | ITEMS                                        |  | SETTING /CONTENTS |               |                                 |  |
|-----|----------------------------------------------|--|-------------------|---------------|---------------------------------|--|
| 1   | Downward Synch Code (31 bit)                 |  | OFF               | Allowance "5" | Do not change settings locally. |  |
| 2   |                                              |  | ON                |               |                                 |  |
| 3   |                                              |  | OFF               |               |                                 |  |
| 4   | Temperature/depth/upward Synch Code (16 bit) |  | ON                | Allowance "2" |                                 |  |
| 5   |                                              |  | OFF               |               |                                 |  |
| 6   |                                              |  | ON                |               |                                 |  |
| 7   | Not used                                     |  |                   |               |                                 |  |
| 8   |                                              |  |                   |               |                                 |  |

Note: Factory settings shown in shading.

# CHAPTER 6 TROUBLESHOOTING

## 6-1. SELF-CHECK

The CN-24 is equipped with self checks for checking the display unit for proper operation.

### Procedure

- (1) Turn off the POWER if it is not already off.
- (2) While pressing any key, turn on the POWER. In a few seconds, the self check screen appears. The EVENT key functions to select a self check: panel switch check and device/function check.
- (3) To exit from the self-check mode, turn off the power.

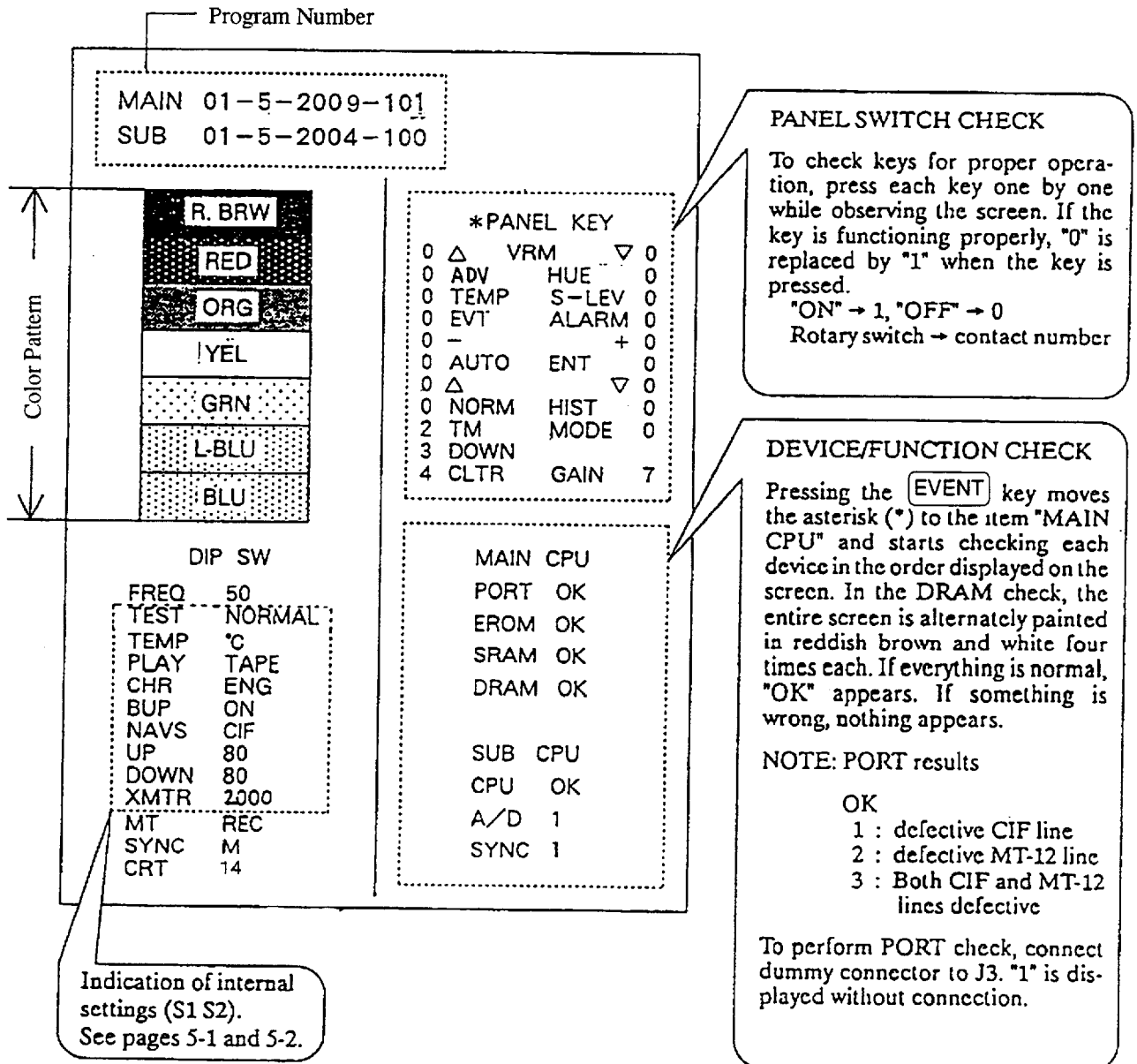

## 6-2. TROUBLESHOOTING FOR THE USER

This section provides troubleshooting procedures for the user.

### NO ECHOES APPEAR BUT SCALES AND VRM DO

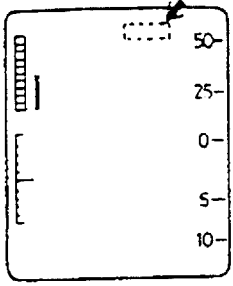

1) Is the picture advance speed set at other than "STOP"?  
2) Are echoes received from the transmitter? Confirm signal level by switching on the graphic display.

### LOW SENSITIVITY ( Seabed and fish school not well displayed)

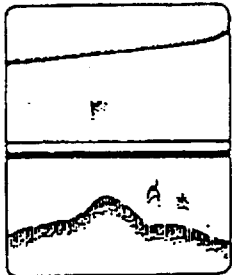

1) Is the GAIN Control on the control panel properly set?  
2) Is the sounding rate in the transmitter unit set to "LOW"?  
3) Is the NOISE LIMITER setting on the MENU screen set too high?

### PICTURE UNDULATES

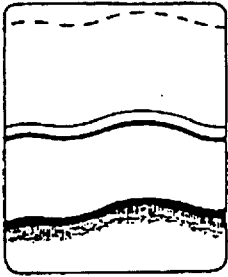

1) Are magnetic field-generating machines (heavy duty transformer, rectifier, etc.) nearby? If so, turn them off one by one to locate the offending unit.

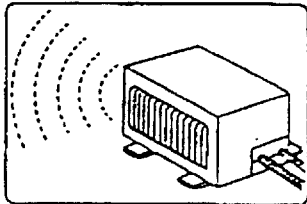

### PICTURE COLOR ABNORMAL

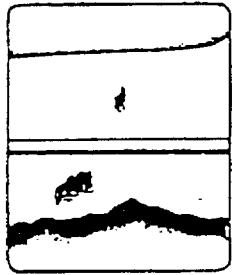

1) Is the BRILLIANCE Control properly set?  
2) Note that the color may appear brighter or darker as the room lighting is changed.

## PICTURE COLOR PARTIALLY ABNORMAL

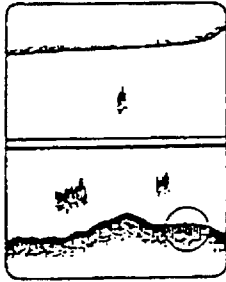

- 1) Is a magnet-equipped device such as a speaker near the equipment? Turn off the equipment and turn it on again. If abnormal color still persists, request service.

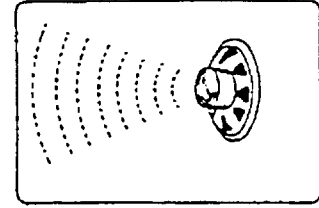

## OCCASIONAL DISTURBANCE/RANDOM NOISE

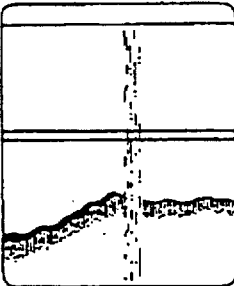

- 1) Do the cables of other equipment run close to and in parallel to the cables of the color net recorder? If so separate them.

## NOISE/INTERFERENCE

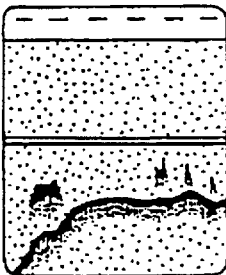

- 1) Is the GAIN control on the control panel properly set? Too high a setting tends to display noise.
- 2) Is the equipment properly grounded with a copper strap?
- 3) When noise is due to contaminated water, adjust the CLUTTER Control.

# ***SPECIFICATIONS OF COLOR NET RECORDER CN-24***

---

## **DISPLAY UNIT CN-2410**

### **1. Display**

14" diagonal, rectangular CRT

Echo: presented in 7 color graduations (with selectable background color)

Temperature: presented in graphical form and digital value.

### **2. Presentation Mode**

(1) Downward mode

(2) Upward + downward mode

(3) True Motion (upward + downward) mode

Each mode incorporates Normal and Historical picture advancement modes.

### **3. Basic Display Range**

|                     | Range                                         | 1  | 2  | 3  | 4   |
|---------------------|-----------------------------------------------|----|----|----|-----|
| Downward/<br>Upward | Meters<br>Fathoms<br>Feet<br>Passi/<br>Brazas | 10 | 20 | 30 | 40  |
| True<br>Motion      | Meters<br>Fathoms<br>Feet<br>Passi/<br>Brazas | 20 | 40 | 80 | 160 |

#### Notes

- 1) Display start range can be shifted in 1 m (fa, ft, p/b) steps.
- 2) Basic Display Range is programmable on the Menu Screen.
- 3) Unit is selectable by internal DIP switch.

#### **4. Range Shift**

(Available on True Motion mode only)

Manual: 0-2000 m, 0-1080 fa, 0-3280 ft, 0-1200 P/B

Auto: The net trace shifts to the center of the screen when it comes to 1/4 or 3/4 of the screen from the top.

#### **5. Display Advancement**

Normal Mode: OFF (Freeze), 1/8, 1/6, 1/4, 1/2 1/1 (Scan line/transmission)

Historical Mode: 5/10/15/30/60/90/120 (minutes/screen)  
Six hours of observation is available in Down ward mode.

#### **6. Net Depth Indication**

0-2000 m

#### **7. Temperature Indication**

Digital Readout:  $-5^{\circ}\text{C} \sim +40^{\circ}\text{C}$  in  $0.1^{\circ}\text{C}$  step  
( $20^{\circ}\text{F} \sim 100^{\circ}\text{F}$  in  $0.2^{\circ}\text{F}$  step)

Graph: plotted in the interval of  $\pm 5^{\circ}\text{C}$  ( $\pm 10^{\circ}\text{F}$ ). When the temperature rises above or falls below the limits of the scale, the graph is shifted to the center of the scale.

#### **8. Marker & Digital Readout**

Marker: Minute marker, VRM marker.

Readout: Net depth, temperature (L/L data & time is displayed when connected with nav. system.)

#### **9. Input/ Output Data\* (CIF or NMEA Format)**

Input: Ship's position (L/L), Ship's speed, ship's bearing, time

Output: Net depth, temperature (CIF only)



## 10. Output for External Display/Recorder Unit

- 1) Echo Signal (upward/downward)
- 2) Net depth (Requires synchro signal (KP) input.)

Requires optional E/S interface kit (OP01-5). Echo Signal can be connected to the color video sounder/recorder which has monitor channel.

## 11. Picture Record/Playback

Requires picture Recorder MT-12 (Optional MT-12 interface kit when connecting with MT-12.)

## 12. Power Supply and Consumption

10-40 VDC, less than 100 W

100/110/115/200/230 Vac, 50-60 Hz, 1  $\phi$  (optional rectifier RU-3423 is required.)

## PARAVANE RECEIVER ND-85XX

### 1. Frequency and Beamwidth

| Frequency | Beamwidth          |
|-----------|--------------------|
| 33 kHz    | 34 degrees (-3 dB) |
| 40 kHz    | 30 degrees (-3 dB) |
| 50 kHz    | 28 degrees (-3 dB) |

### 2. Transducer Tilt Angle

Adjustable to 15°, 25° or 35° below horizontal

### 3. Maximum Pressure

5 kg/cm<sup>2</sup> (equivalent to 50 m)

### 4. Cable length & Strength

70 m, tensile strength more than 1000 kgf

### 5. Towing Speed

Normal reception up to 6 knots

# TRANSMITTER UNIT CN-2220

## 1. Signal Transmission Characteristics and Operating Hour of Battery Pack

| Frequency | Output | Beamwidth   | Battery operating hour              | Max. Transmission Range* |
|-----------|--------|-------------|-------------------------------------|--------------------------|
| 33 kHz    | 2.4 W  | 34° (-3 dB) | 20 hours (LR-20)<br>10 hours (BP-2) | 3800 m max.              |
| 40 kHz    |        | 32° (-3 dB) |                                     | 3000 m max.              |
| 50 kHz    |        | 28° (-3 dB) |                                     | 2200 m max.              |

| Frequency | Output | Beamwidth   | Battery operating hour            | Max. Transmission Range* |
|-----------|--------|-------------|-----------------------------------|--------------------------|
| 33 kHz    | 10 W   | 34° (-3 dB) | 9 hours (LR-20)<br>5 hours (BP-2) | 4500 m max.              |
| 40 kHz    |        | 32° (-3 dB) |                                   | 3600 m max.              |
| 50 kHz    |        | 28° (-3 dB) |                                   | 2800 m max.              |

\* affected by sea condition

## 2. Signal Transmission Mode

Synch pulse: Frequency shift code modulation

Echo: Frequency modulation

Depth/Water Temp: Pulse position modulation

## 3. Sounding Characteristics

| Frequency | Output | Beamwidth   | Minimum Range | Max Detection Range |
|-----------|--------|-------------|---------------|---------------------|
| 75 kHz    | 100 W  | 33° (-3 dB) | 1.5 m         | 640 m               |
| 175 kHz   | 100 W  | 15° (-3 dB) | 1.5 m         | 200 m               |

## 4. Sounding Rates, Sounding Range

|      | Sounding Rate     | Sounding Range |
|------|-------------------|----------------|
| Low  | 28-68 times/min.  | 0-640 m        |
| High | 83-206 times/min. |                |

## 5. Pulselength

0.6ms (75 kHz), 0.2ms (175 kHz)

## 6. Temperature Measurement

-5°C to +40°C or 20°F to 100°F (Accuracy ± 0.5%)

## 7. Maximum Depth & Ambient Temperature

2000 m, -10°C~+40°C

## 8. Power Supply

12 VDC, Alkali dry cell LR-20 8 pcs. or Ni-Cd battery pack BP-2 (option)

Automatically switched on upon sensing sea water.

## EQUIPMENT LIST

| No. | Name                   | Type       | Code Number | Weight  | Qty   | Remark                                                        |
|-----|------------------------|------------|-------------|---------|-------|---------------------------------------------------------------|
| 1.  | Display Unit           | CN-2410    |             | 20.0 kg | 1     |                                                               |
| 2.  | Transmitter Unit       | CN-2220    |             | 25.0 kg | 1     | Specify frequency and material of fixing plate when ordering. |
| 3.  | Paravane Receiver      | ND-87XX    |             | 35.0 kg | 1     | Specify frequency.                                            |
| 4.  | Accessories            | FP01-01000 | 000-060-117 |         | 1 set |                                                               |
| 5.  | Installation Materials | CP01-01200 | 000-060-124 |         | 1 set |                                                               |
| 6.  | Spare Parts            | SP01-00900 | 000-060-123 |         | 1 set |                                                               |

## INSTALLATION MATERIALS

| No. | Name               | Type           | Code Number | Qty | Remark |
|-----|--------------------|----------------|-------------|-----|--------|
| 1.  | Earth Plate        | WEA-1004-D     | 500-310-040 | 1   |        |
| 2.  | Power Cable Assy.  | P01-5-3.5 (3P) | 002-173-770 | 1   |        |
| 3.  | Connector          | NCS-254-P      | 000-506-505 | 1   |        |
| 4.  | Connector          | SRCN6A-16P     | 000-508-663 | 1   |        |
| 5.  | Crimp-on Lug       | FV2-4 (blue)   | 000-538-118 | 4   |        |
| 6.  | Heat Shrink Tubing | 12x0.25*20 mm* | 000-568-194 | 1   |        |

## OPTION

| No. | Name                     | Type          | Code Number | Remark                      |
|-----|--------------------------|---------------|-------------|-----------------------------|
| 1.  | Paravane Receiver        | CN-2030-40    | 000-060-444 | For 40 kHz.                 |
|     |                          | CN-2030-50    | 000-060-445 | For 50 kHz.                 |
| 2.  | Spare Transducer         | CN-2031-40    | 000-060-451 | For 40 kHz with 50 m cable. |
|     |                          | CN-2031-50    | 000-060-452 | For 50 kHz with 50 m cable. |
| 3.  | Hull Receiver            | T-228 1 set   |             |                             |
| 4.  | Net-recorder Hull Unit   | HD-810        |             |                             |
| 5.  | Ni-Cd Battery Pack       | BP-2          | 000-063-394 | For transmitter unit.       |
| 6.  | Battery Charger          | BC-8          | 000-063-391 |                             |
| 7.  | Rectifier                | RU-3423       | 000-030-443 |                             |
| 8.  | Picture Recorder         | MT-12         | 000-060-144 |                             |
| 9.  | E/S Interface Kit        | OP01-5        | 000-060-454 |                             |
| 10. | MT-12 Interface Kit      | OP01-7        | 000-060-456 |                             |
| 11. | Transducer Switch Box    | RS-80         | 000-060-139 |                             |
| 12. | SW Box Interface         | OP01-13       | 004-553-600 | For RS-80.                  |
| 13. | Transmitter Unit         | CN-2020-I-40  | 000-060-400 | 40, 50 kHz, select one.     |
|     |                          | CN-2020-N-40  | 000-060-410 |                             |
|     |                          | CN-2020-I-50  | 000-060-420 |                             |
|     |                          | CN-2020-N-50  | 000-060-430 |                             |
| 14. | Battery Charger          | CN-2040       | 000-060-143 |                             |
| 15. | Transmitter Battery Pack | CN-2225       | 000-060-451 |                             |
| 16. | Vinyl Cover              | 10-044-0031-1 | 000-801-859 | for display unit            |

# APPENDIX A. Changing Signal Transmitting Power

The signal transmitting power can be changed from 2.4 W to 10 W or vice versa by changing the jumper connections on the CONT-A Board (01P5740).

Note: Increasing output power decreases the battery operating hour by 50% approximately.

| TX Freq. | Jumper Settings |      |      | Output Power |
|----------|-----------------|------|------|--------------|
|          | Jxx1            | Jxx2 | Jxx3 |              |
| 33 kHz   | A-LA            | B-LB | 2    | 2.4 W        |
|          | A-HA            | B-HB |      | 10 W         |
| 40 kHz   | A-LA            | B-LB | 2    | 2.4 W        |
|          | A-HA            | B-HB |      | 10 W         |
| 50 kHz   | A-LA            | B-LB | 1    | 2.4 W        |
|          | A-HA            | B-HB |      | 10 W         |

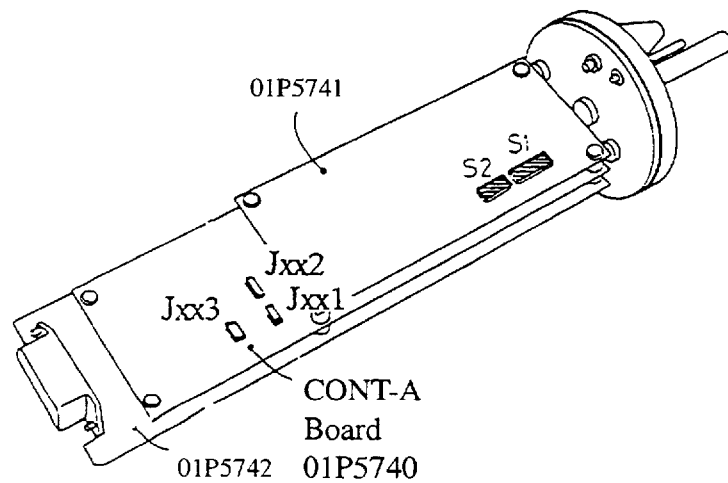

Fig. A Location of jumper blocks on CONT-A board

## APPENDIX B. Connecting with Echo Sounder FE-1282

The upward/downward sounding picture can be plotted on the external echo sounder FE-1282 when the optional E/S interface kit is fitted. Connect with FE-1282 as follows:

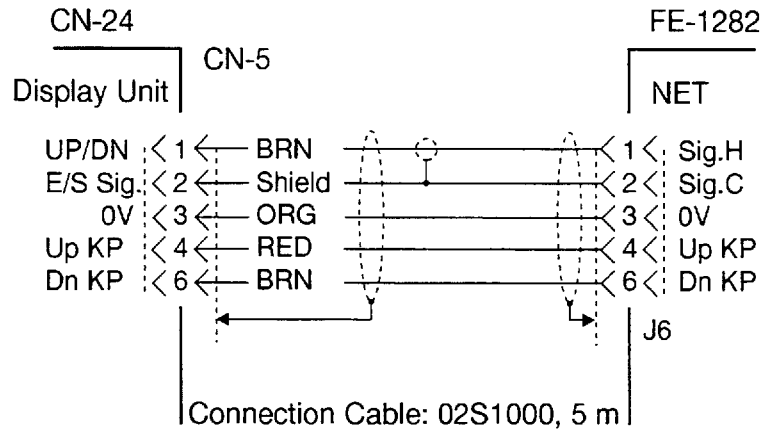

Fig. B Connection with FE-1282

## APPENDIX C. Plotting of Net Depth Mark on other Color Video/ Echo Sounder

The net depth mark can be painted on other color video sounder when the optional E/S interface kit is fitted.

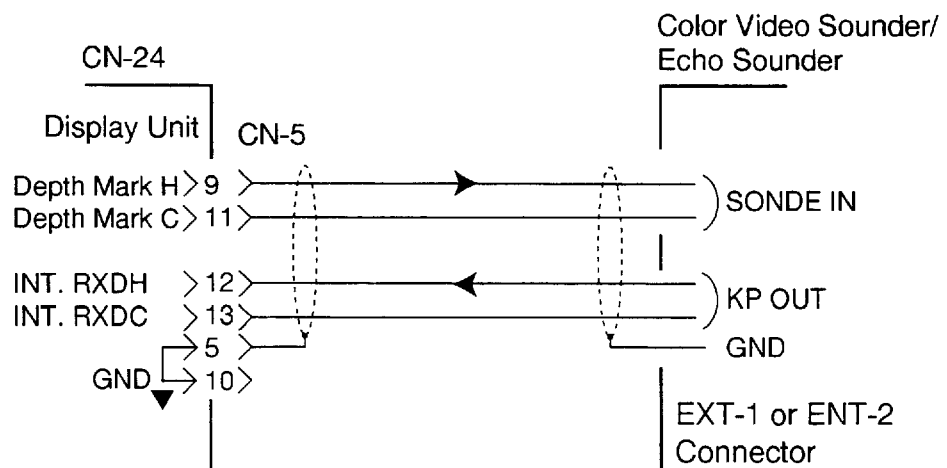

Fig. C Connection with color video/echo sounder

# APPENDIX D. Hull Bottom Transducers

## Installation

### General

Installing the receiver transducers on the hull bottom eliminates the paravane receiver and boom. This eliminates the troublesome task of looking after the paravane cable. It is however recommended to keep on board the paravane receiver as a reserve aid because the bottom transducers are not a decisive means to pick up signals coming from the transmitter unit in every case. The paravane receiver is more effective than the bottom transducer arrangement in adverse conditions.

For reference, Japanese trawlers operating in various parts of the world are equipped with hull bottom transducers and are experiencing good performance with our net recorder.

Hull bottom transducers work best under the following conditions:

1. Trawlers larger than 250 tons.
2. Water deeper than 150 meters (80 fathoms).

See tank drawing (Dwg. No. E2001-137). Three transducers are installed and switched at the bridge for maximum pick-up of signals coming from the transmitter.

The transducer installation angle (65 degrees in the drawing as an example) should be decided according to the trawling condition (warp length, net depth, etc.).

Note: To minimize the interference from the echo sounder, separate the cable for hull bottom transducers from the transducer cable of echo sounder and pass them thorough

## Installation Zone of Transducer Tank

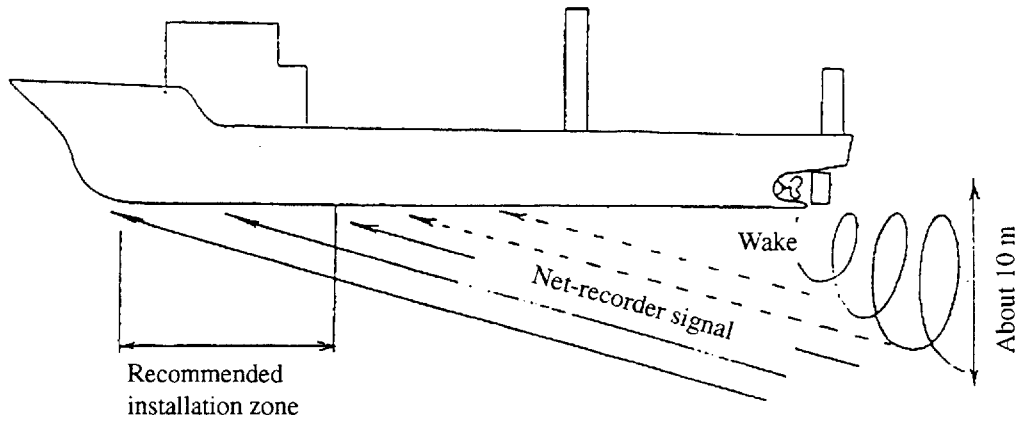

Fig. D

Note: To minimize the interference from the echo sounder, separate the cable for hull bottom transducers from the transducer cable of echo sounder and pass them through separate grounded steel pipes.

## Transducer Switch Box (RS-80)

Mount the transducer switch box adjacent to the display unit so that the best receiving condition can be selected by the switch box while observing to the picture on the screen.

## Operation

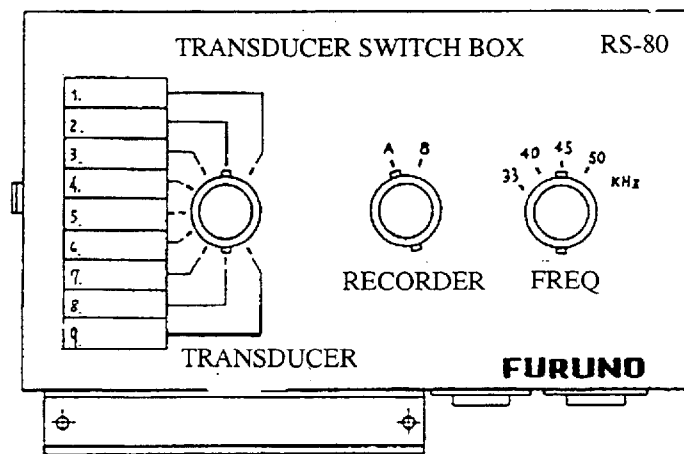

### TRANS-DUCER SELECTOR

Select for the best receiving condition.

Paravane receiver ..... 1

Hull bottom transducers ..... 2, 3, 4, 5, 6, 7, 8, 9

### RECORDER SELECTOR

A ..... Main Display Unit

B ..... Sub Display Unit

### FREQUENCY SELECTOR

Select the same frequency as TX unit.



## APPENDIX E. CN-2030 Paravane Receiver (optional supply)

### Operation

The paravane receiver should be put into the water slowly (after throwing the net) and retracted before the trawl is hauled up. To obtain stable receiving performance and avoid the effect of air bubbles, submerge the paravane receiver deeply and keep it away from the boat as much as possible. The figure below illustrates this condition.

The paravane receiver is normally towed by a 5 to 10 m boom which is extended from the stern side of the boat. This boom has wooden blocks at its ends through which the cable is guided.

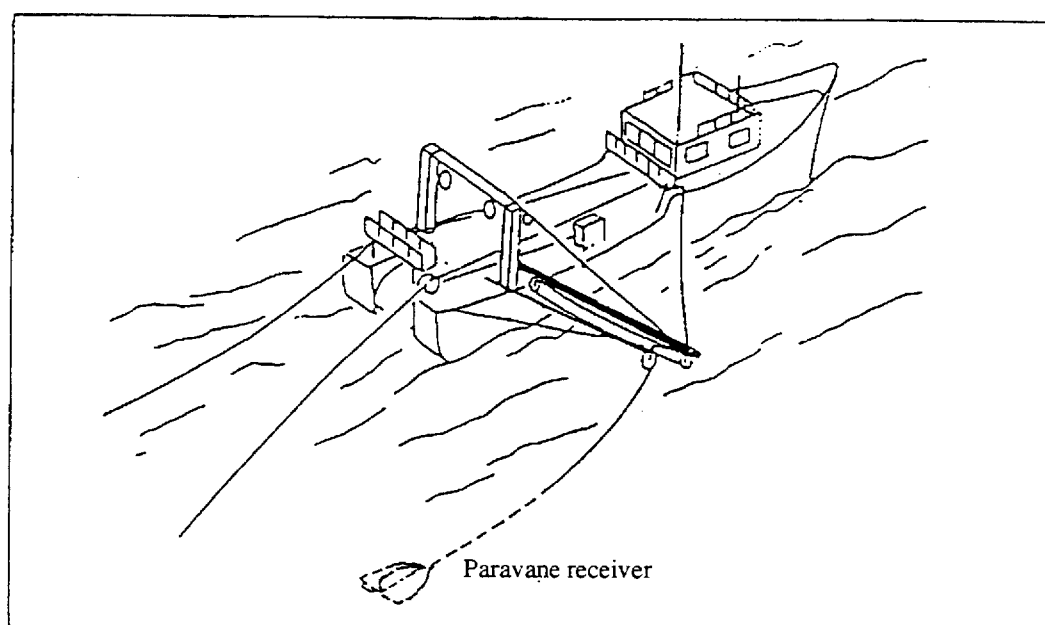

*Fig. E-1*

### Cable Length

Generally, a longer cable is better for signal reception. The cable length from the boom must be 20 meters or longer.

If the cable is too short, the paravane receiver will drift towards the propellers and the aerated water produced there or propeller noise will have an adverse effect on the receiving conditions.

With the cable long enough, the paravane receiver submerges, stabilizes, and positions itself 7 to 8 meters below the surface.

If an ocean current or tidal current pushes the net sideward it also pushes the paravane receiver in the same direction, thus the transmitter unit and the paravane receiver are kept in alignment as shown in Fig. E-2.

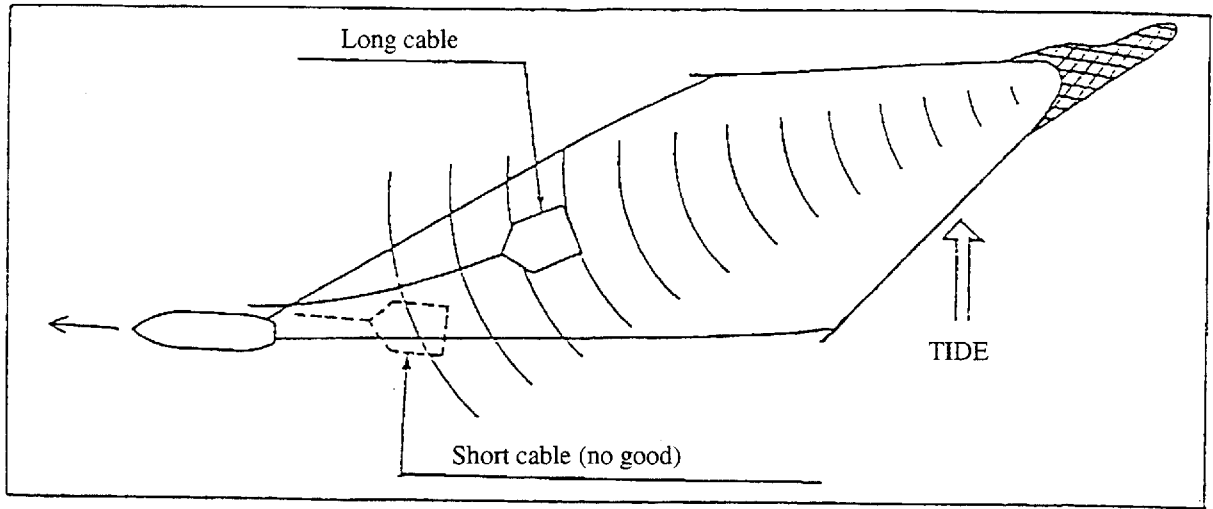

Fig. E-2

### Tilt Angle Adjustment

The paravane receiver tilt angle can be adjusted in two steps: 15 and 25 degrees from the horizon. Read out the suitable angle from Fig. E-3, considering the depth of the trawl and length of the warp.

Fig. E-3 shows the beamwidth for 50 kHz receiver. In case of the 40 kHz receiver, the beamwidth is 40 degrees.

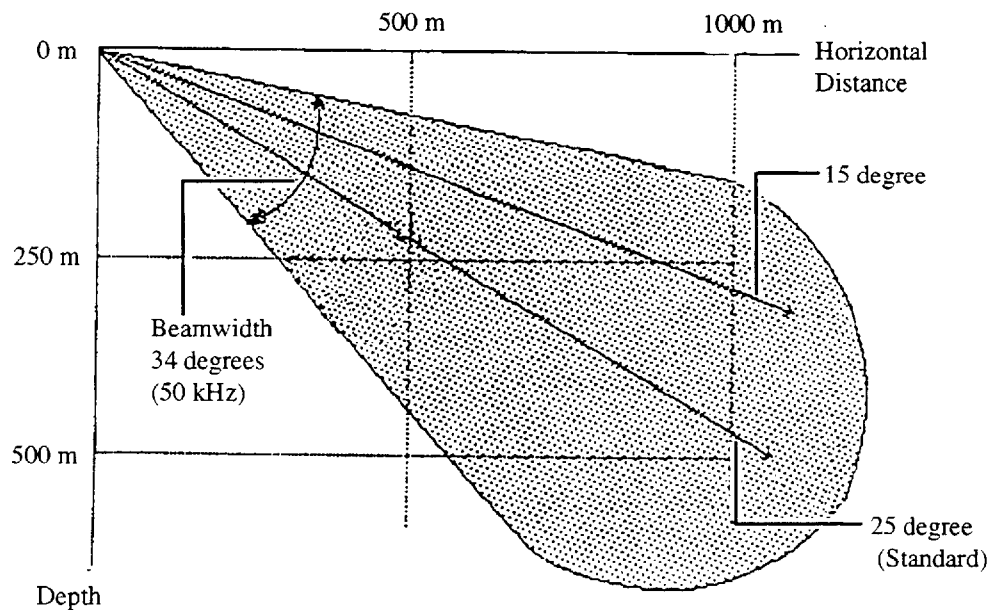

Fig. E-3

To adjust tilt angle do the following:

- 1) Remove the transducer housing by loosening four M6 x 16 fixing screws.
- 2) Remove the angle spacer by loosening four M8 x 15 fixing screws.
- 3) Reversely fix the angle spacer.

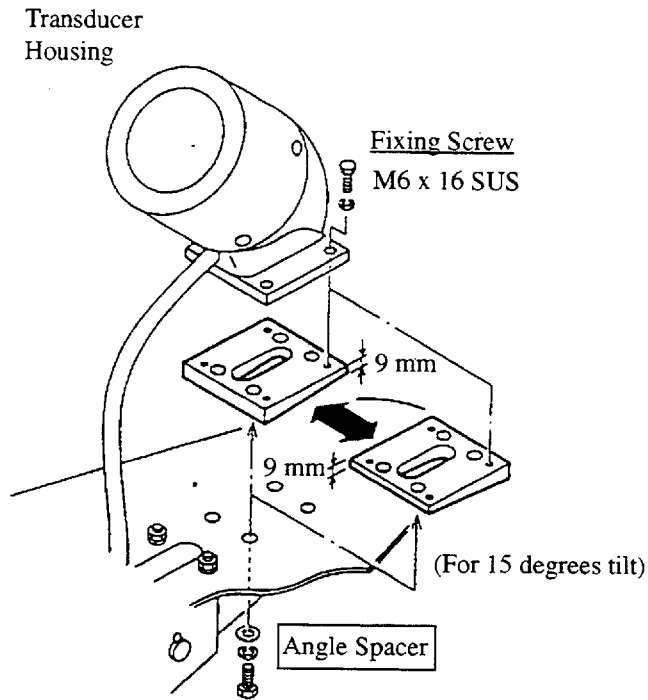

Fig. E-4

## Balancing Block

The paravane receiver has a balancing block on each horizontal wing. Use the paravane with two balancing blocks (factory assembling) in normal operation. However if you need to keep the paravane away from your boat to escape propeller noise or air bubbles, take out the balancing block which is nearest your boat.

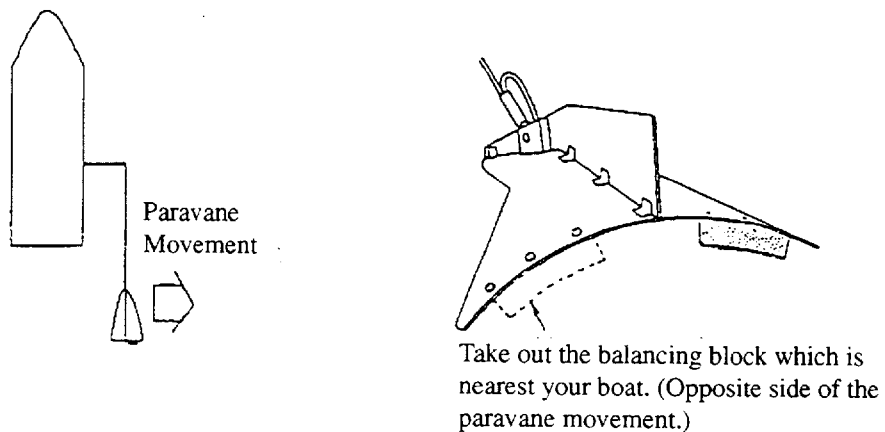

Fig. E-5

## Replacement of Transducer

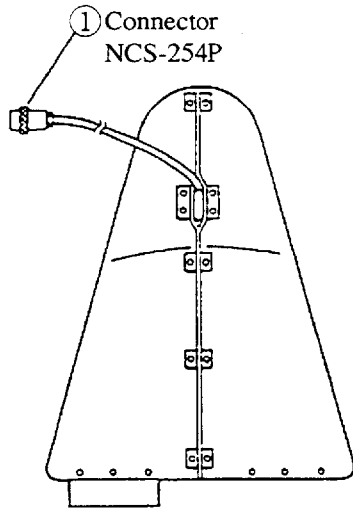

Fig. E-6

1. Disassemble the connector (①) and unsolder the cable leads.
2. Take out the split pin (② x 2) and release the thimble.
3. Loosen four fixing screws (③) to dismount the transducer case.
4. Take out the transducer assembly through the hole (A).
5. Fit a new transducer assembly on the paravane by doing steps 1-4 in reverse order.

## Remarks on assembling new transducer

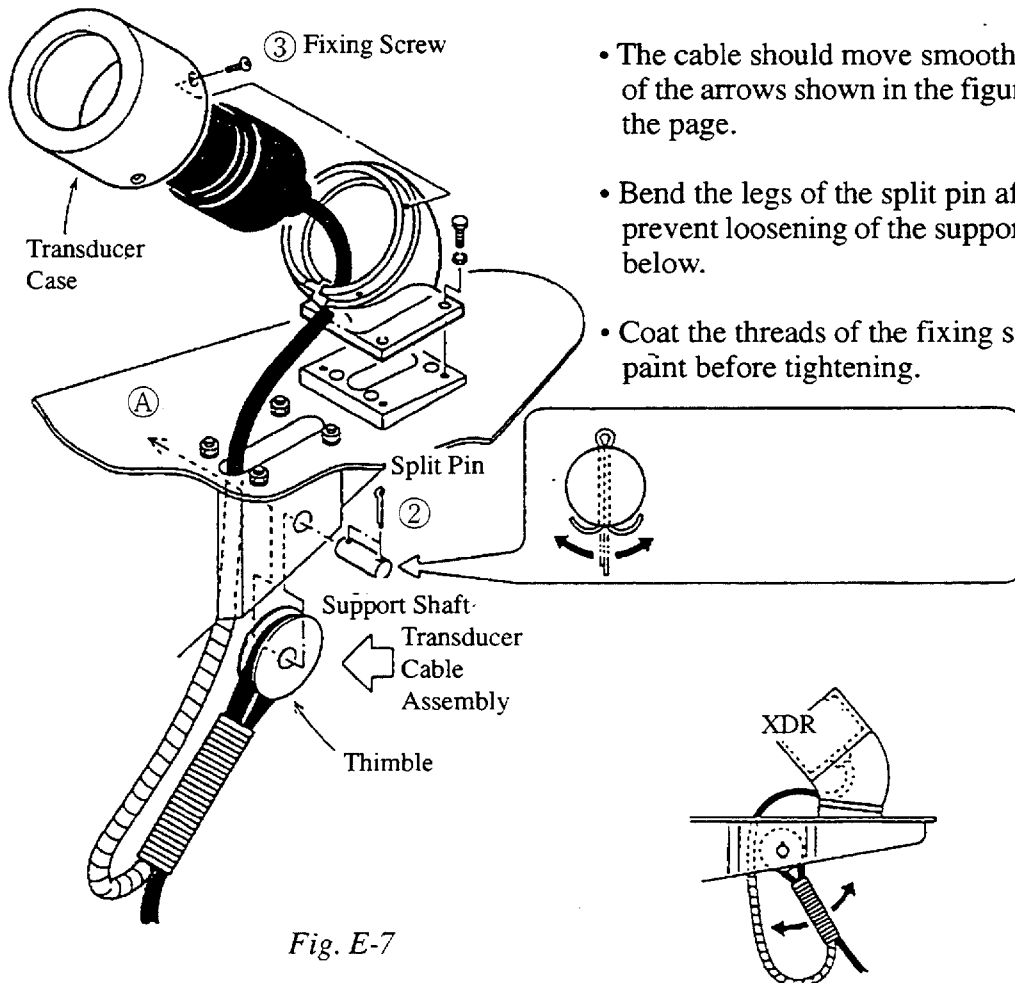
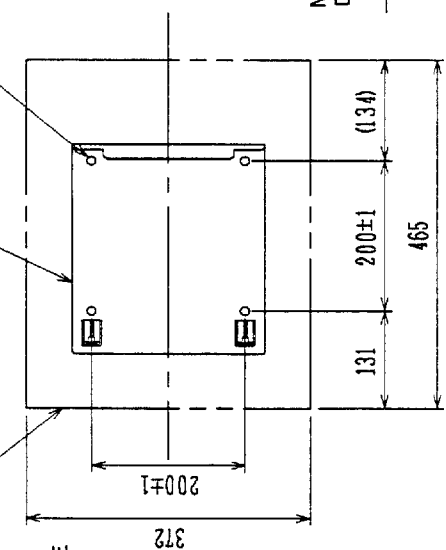

Fig. E-7

- Be sure the cable is not twisted.
- The cable should move smoothly in the direction of the arrows shown in the figure at the bottom of the page.
- Bend the legs of the split pin after inserting it, to prevent loosening of the support shaft. See figure below.
- Coat the threads of the fixing screw with lock paint before tightening.

FRONT PANEL 前面パネル側  
PEDESTAL 取付台  
FIXING HOLES 4-φ12 取付穴



注 記 NOTE

- 1) 接続ケーブルはサービスタブ、指示部を前方に充分引き出せるよう余裕を持たせること。
  - 2) 取付用ボルトはM10ボルトまたはコーチボルト呼び径φ9を使用のこと。
  - 3) #印寸法は最小サービスタブ空間寸法とする。
- 1) KEEP ENOUGH CABLE LENGTH BEHIND DISPLAY
  - 2) USE M10 BOLTS OR φ9 COACH BOLTS FOR FIXING DISPLAY UNIT.
  - 3) DIMENSIONS WITH "#" INDICATES RECOMMENDED SERVICE CLEARANCE

MOUNTING DIMENSIONS 取付穴寸法図



表 1 TABLE 1

| 範囲 DIMENSIONS   | 公差 TOL  |
|-----------------|---------|
| L ≤ 50          | ± 1 mm  |
| 50 < L ≤ 100    | ± 2 mm  |
| 100 < L ≤ 500   | ± 3 mm  |
| 500 < L ≤ 1000  | ± 4 mm  |
| 1000 < L ≤ 2000 | ± 5 mm  |
| 2000 < L ≤ 4000 | ± 7 mm  |
| 4000 < L ≤ 8000 | ± 10 mm |
| 8000 < L        | ± 15 mm |

|                                  |                         |
|----------------------------------|-------------------------|
| DRAWN 1996.8.9<br>Y. EBISU       | TITLE CN-24             |
| CHECKED 1996.8.16<br>K. Kusunoki | 名称 カラーネットレコーダ           |
| APPROVED 1996.9.6<br>K. Ueta     | 外 寸 図                   |
| SCALE 1/10<br>MASS 22±2kg        | NAME COLOR NET RECORDER |
| DWG No. C1301-G01-A              | OUTLINE DRAWING         |
|                                  | 01-022-1000-G0          |

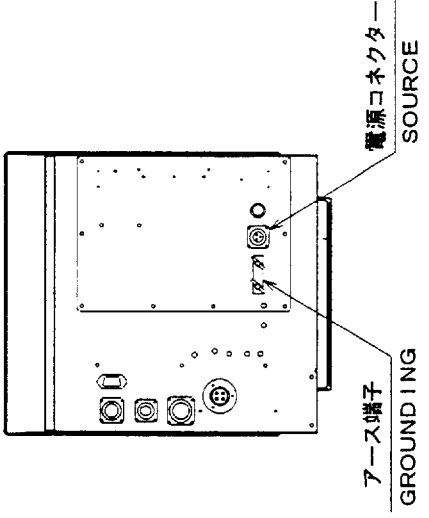
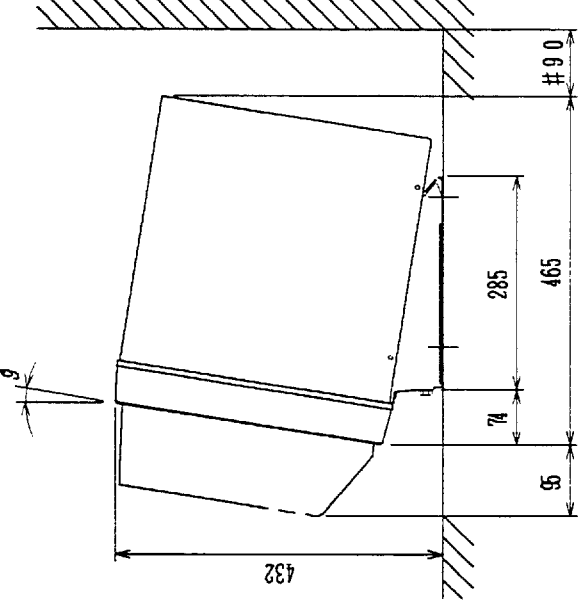
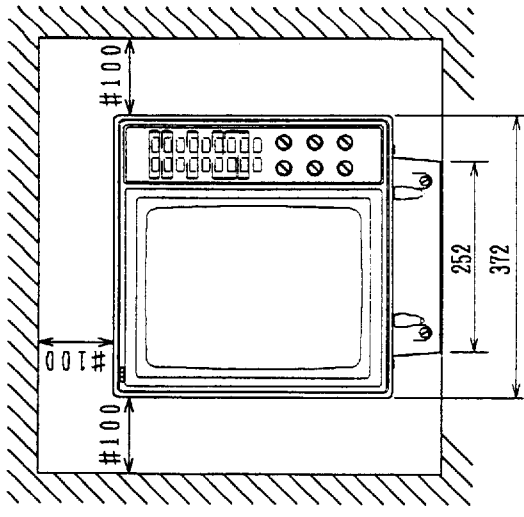
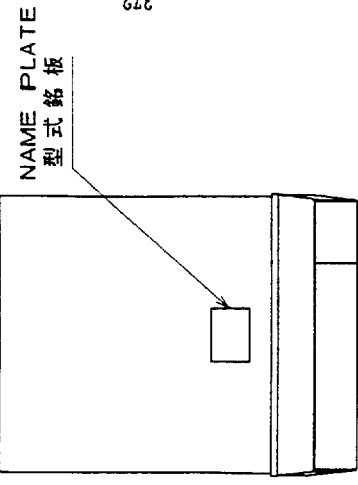
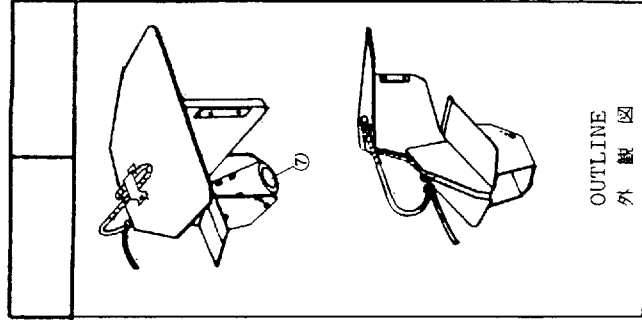

型式の見方  
TYPE IDENTIFICATION

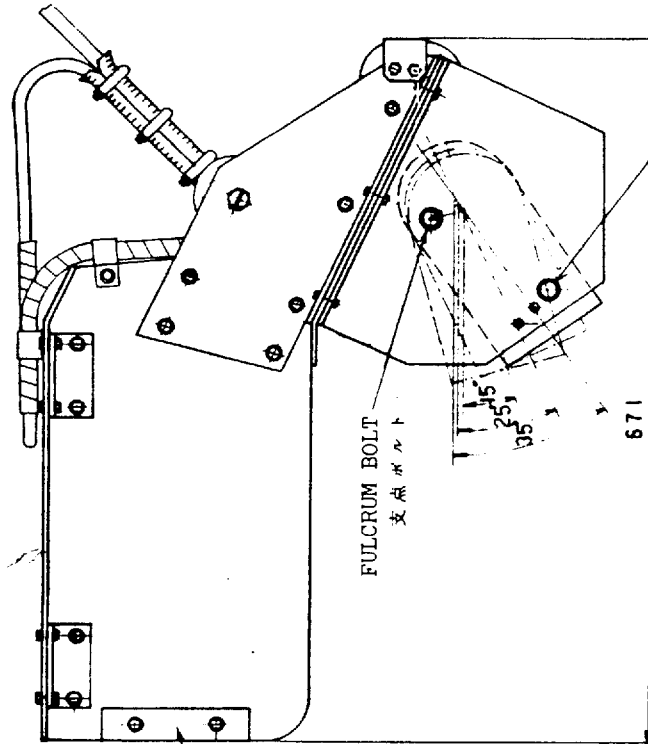
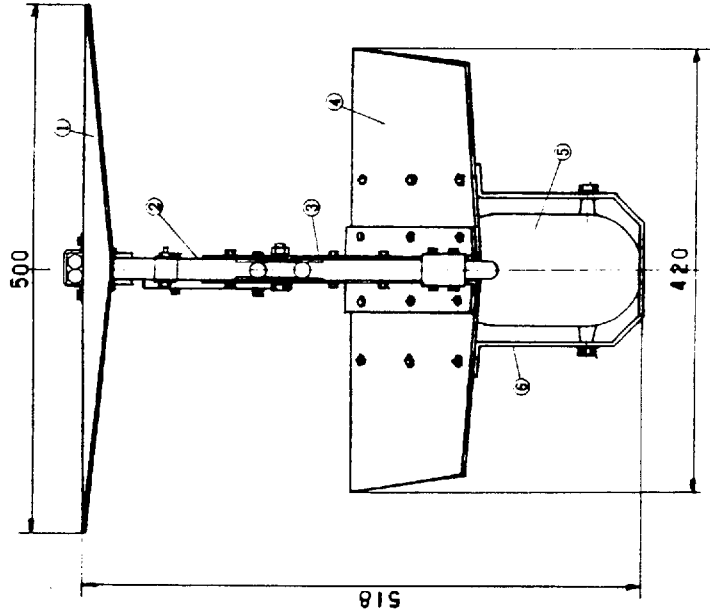
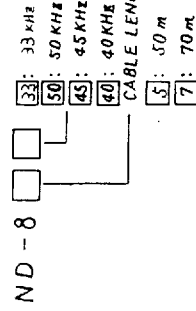

TILT ADJUSTING BOLT. SEE NOTE 2.  
俯角調整ボルト 注2参照。

NOTE:

1. THE BALANCING BLOCK CAN BE BOLTED ON EITHER SIDE TO OFFSET THE TOW COURSE OF THE PARAVANE. THE CORRECT POSITION FOR THE BLOCK IS THE OPPOSITE TO THE SHIP.
2. THE TRANSDUCER TILT ANGLE CAN BE ADJUSTED IN THREE STEPS, I.E., 15, 25 AND 35 DEGS. FROM HORIZONTAL PLANE, BY SETTING THE TILT ADJUSTING BOLTS AT ONE OF THREE POSITIONS.

注:

1. デブレッサカーを船体から離して曳航するため方向制御板の取付位置を船体と反対側に変更すること。
2. 受波器の俯角は15度、25度、35度のうちの適切な角度に設定すること。

|         |                       |           |                   |
|---------|-----------------------|-----------|-------------------|
| 7       | TRANSDUCER            | 受波器       | 1                 |
| 6       | XDR CASE FIXING PLATE | 受波器ケース取付板 | 1                 |
| 5       | TRANSDUCER CASE       | 受波器ケース    | 1                 |
| 4       | DESCENDING WING       | 斜翼        | 1                 |
| 3       | SUPPORTING PLATE      | 支持金具      | 1                 |
| 2       | VERTICAL STABILIZER   | 主本体       | 1                 |
| 1       | HORIZONTAL STABILIZER | 水平翼       | 1                 |
| No.     | ITEM                  | MATERIAL  | Q'ty              |
| Scale   | TITLE                 |           |                   |
| Date    | 1981-11               | ND-8      | PARAVANE RECEIVER |
| Checked | デブレッサカー (曳航式受波器)      |           |                   |
| Ref.    | 重量 35kg               | DWG. No.  | C1240-005-B       |

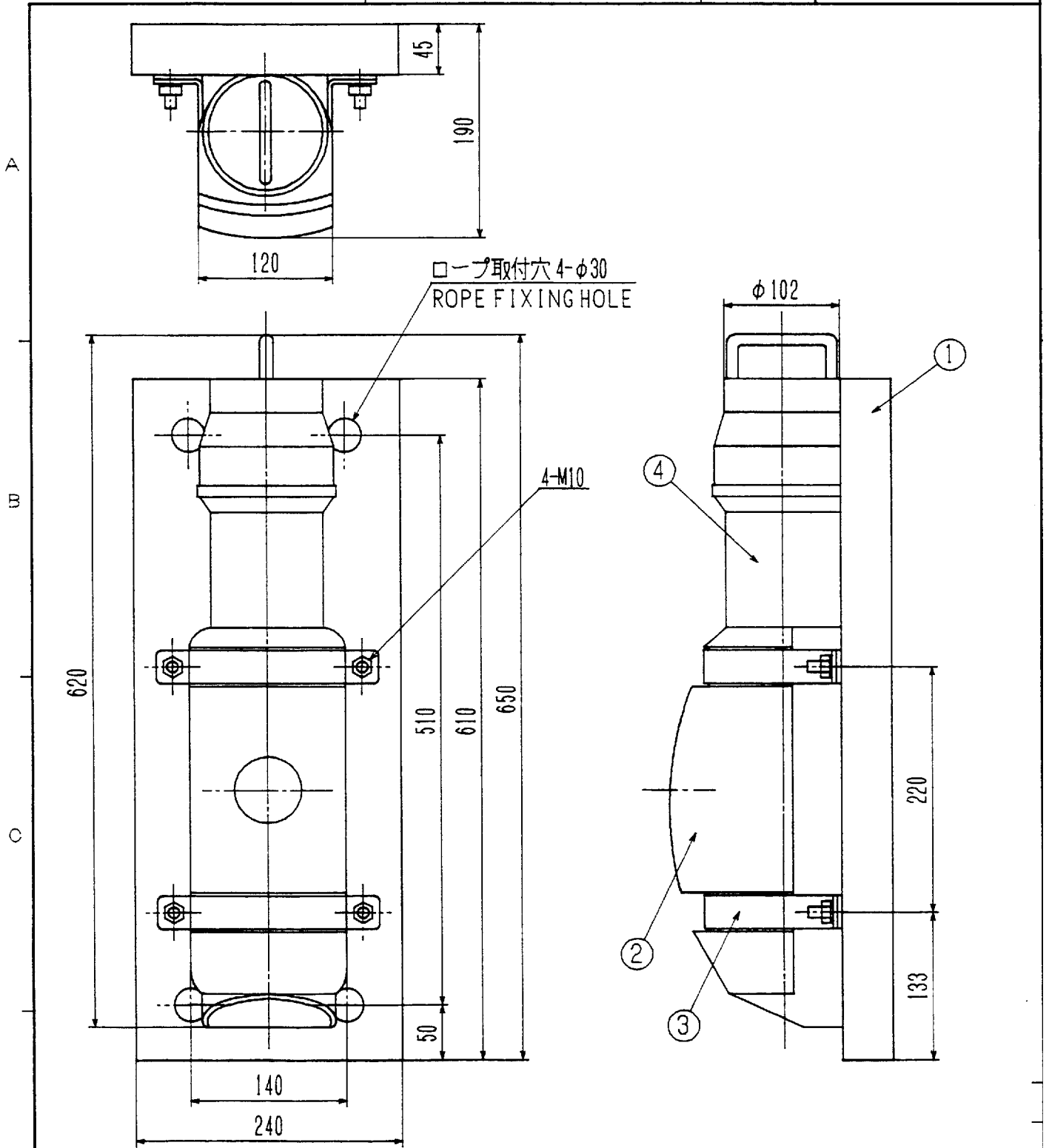

CN-22

| 4          | 発信器組立品<br>TRANSMITTER ASSY   |                | 1         |                |               |
|------------|------------------------------|----------------|-----------|----------------|---------------|
| 3          | 締付バンド<br>FASTENER            | SUS 304        | 2         | NPC-0002-2     |               |
| 2          | 上部電動子カバー<br>PROTECTION COVER | CR             | 1         | NPC-0001-1     |               |
| 1          | 安定板組立品<br>FIXING BOARD       |                | 1         |                |               |
| 品番<br>ITEM | 品名<br>NAME                   | 材質<br>MATERIAL | 数量<br>QTY | 図番<br>DWG. NO. | 摘要<br>REMARKS |

|                |                           |                               |       |                          |             |
|----------------|---------------------------|-------------------------------|-------|--------------------------|-------------|
| 承認<br>APPROVED | SEP. 9. '91<br>T. OKAZAKI | 三角法<br>THIRD ANGLE PROJECTION |       | 名称<br>TITLE              | 発信器         |
| 検図<br>CHECKED  | SEP. 9. '91<br>T. OKAZAKI | 尺度<br>SCALE                   | 1/5   | CN-2220 TRANSMITTER UNIT |             |
| 製図<br>DRAWN    | SEP. 9. '91<br>T. OKAZAKI | 重量<br>WEIGHT                  | 25 kg | 図番<br>DWG. NO.           | C1284-G01-A |

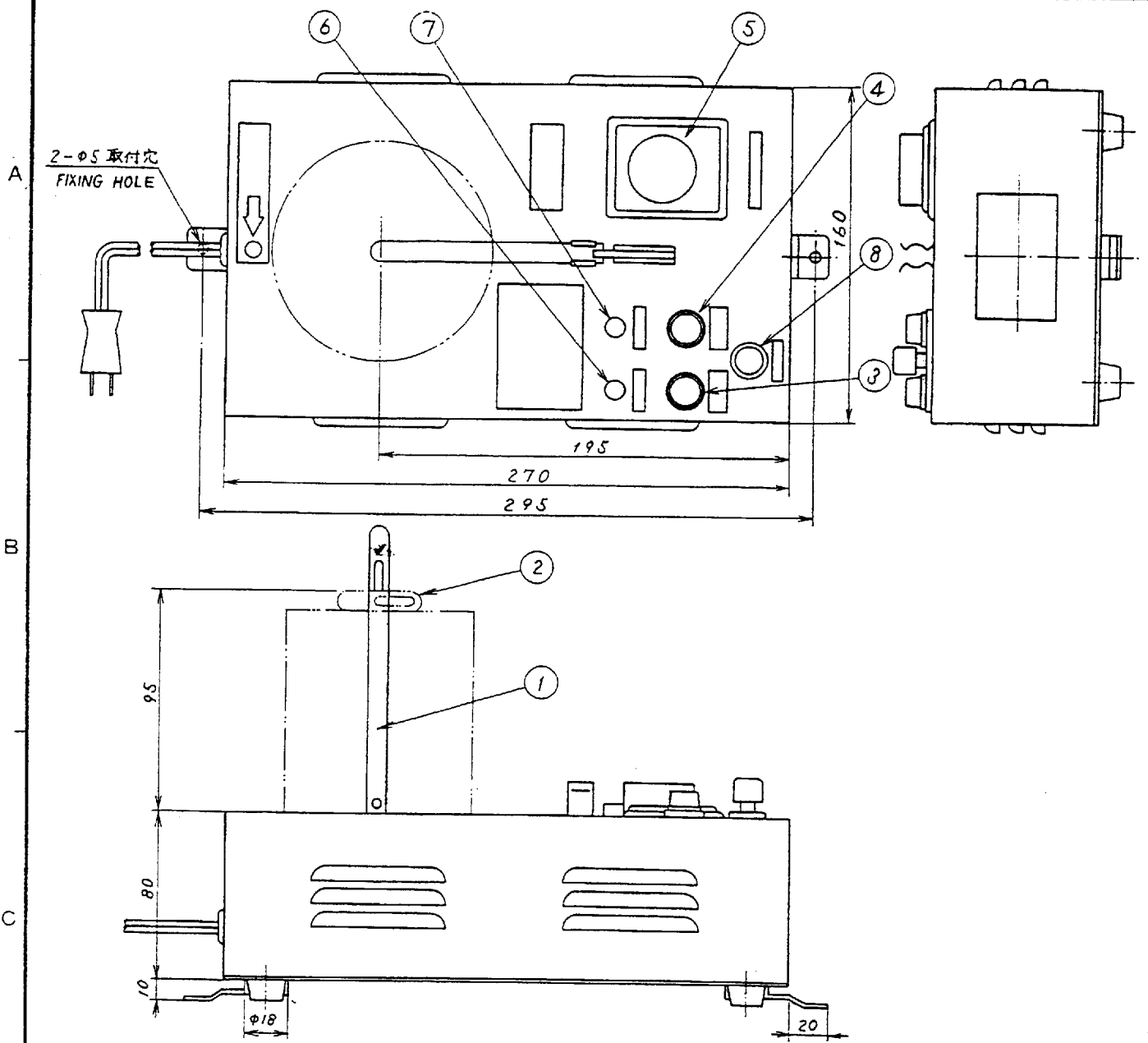

|   |                                    |  |   |  |      |
|---|------------------------------------|--|---|--|------|
| 8 | タイマーリセット押釦<br>TIMER RESET BUTTON   |  | 1 |  |      |
| 7 | 充電表示灯<br>CHARGING INDICATOR        |  | 1 |  |      |
| 6 | 電源表示灯<br>PILOT LAMP                |  | 1 |  |      |
| 5 | タイマー<br>TIMER                      |  | 1 |  |      |
| 4 | 充電ヒューズ<br>FUSE (OUT)               |  | 1 |  | 1A   |
| 3 | 電源ヒューズ<br>FUSE (IN)                |  | 1 |  | 0.5A |
| 2 | 電池ケース押え金具<br>BATTERY CASE RETAINER |  | 1 |  |      |
| 1 | 支持棒<br>SUPPORT BAR                 |  | 1 |  |      |

FNR-80

| 品番<br>ITEM | 品名<br>NAME | 材質<br>MATERIAL | 数量<br>Q'TY | 図番<br>DWG.NO. | 摘要<br>REMARKS |
|------------|------------|----------------|------------|---------------|---------------|
|------------|------------|----------------|------------|---------------|---------------|

|                |                                  |                               |      |                           |  |
|----------------|----------------------------------|-------------------------------|------|---------------------------|--|
| 承認<br>APPROVED | JUN. 9 '83<br><i>[Signature]</i> | 三角法<br>THIRD ANGLE PROJECTION |      | 名称<br>TITLE               |  |
| 検図<br>CHECKED  | MAY. 4 '81<br><i>[Signature]</i> | 尺度<br>SCALE                   | 1/3  | BC-8 充電器<br>CHARGER       |  |
| 製図<br>DRAWN    | OCT. 6 '81<br><i>[Signature]</i> | 重量<br>WEIGHT                  | 3 kg | 図番<br>DWG.NO. C1215-004-A |  |



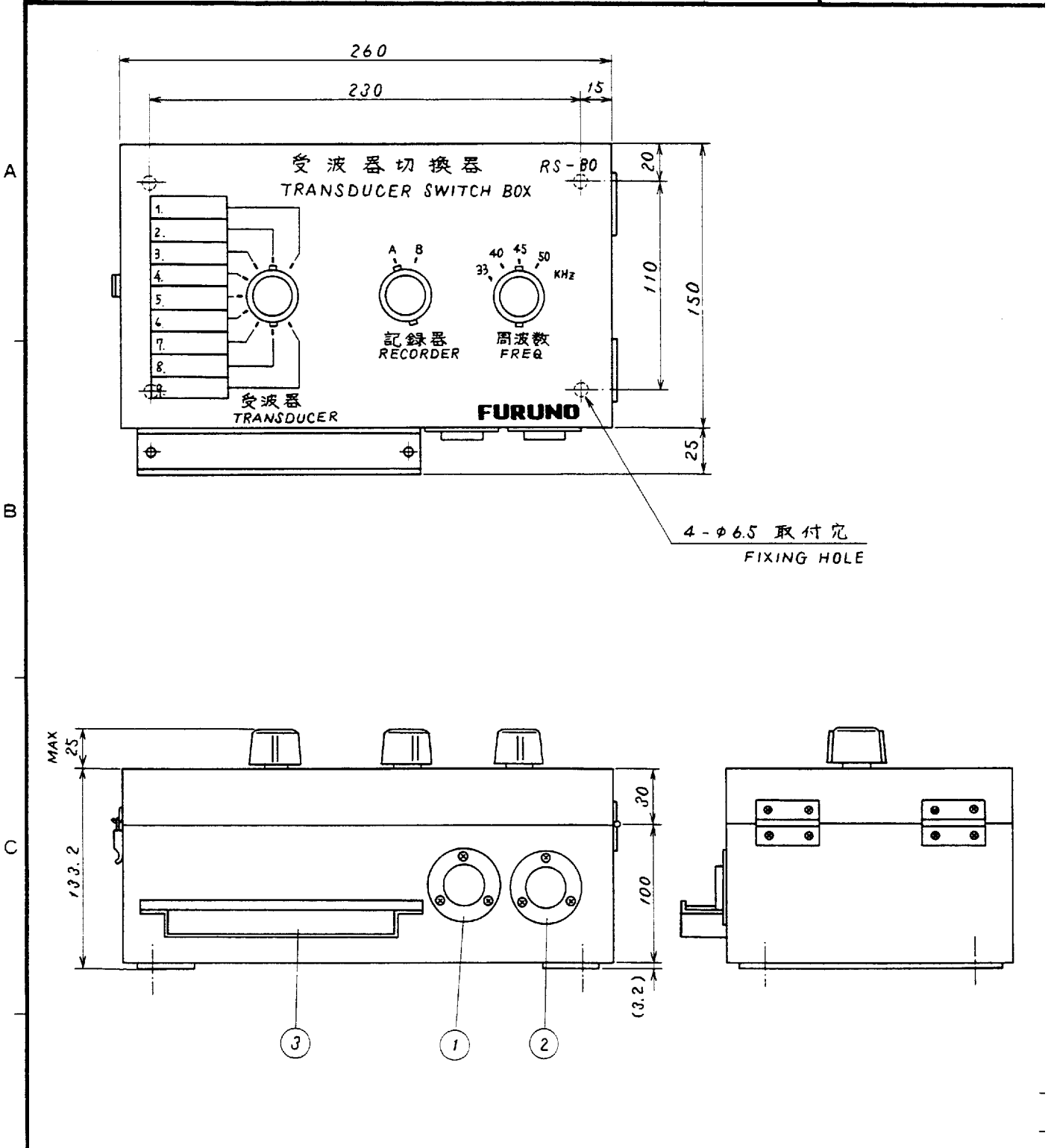

|   |                                          |  |  |  |  |
|---|------------------------------------------|--|--|--|--|
| 3 | 船底受波ケーブル導入口<br>CABLE ENTRY FOR HULL XDR  |  |  |  |  |
| 2 | 記録器B用レセプタクル<br>RECEPTACLE FOR RECORDER B |  |  |  |  |
| 1 | 記録器A用レセプタクル<br>RECEPTACLE FOR RECORDER A |  |  |  |  |

| 品番<br>ITEM | 品名<br>NAME | 材質<br>MATERIAL | 数量<br>Q'TY | 図番<br>DWG. NO. | 摘要<br>REMARKS |
|------------|------------|----------------|------------|----------------|---------------|
|------------|------------|----------------|------------|----------------|---------------|

|                |                                   |                               |                |                                         |
|----------------|-----------------------------------|-------------------------------|----------------|-----------------------------------------|
| 承認<br>APPROVED | JUN. 9 '83<br><i>[Signature]</i>  | 三角法<br>THIRD ANGLE PROJECTION | 名称<br>TITLE    | RS-80<br>受波器切換器<br>TRANSUDER SWITCH BOX |
| 検閲<br>CHECKED  | SEP. 27 '81<br><i>[Signature]</i> | 尺度<br>SCALE                   |                |                                         |
| 製図<br>DRAWN    | SEP. 22 '81<br><i>[Signature]</i> | 重量<br>WEIGHT                  |                |                                         |
|                |                                   | 2.7 kg                        | 図番<br>DWG. NO. | C1240-002-B                             |

Tank No. T-228

80W

40KHZ

45/50KHZ

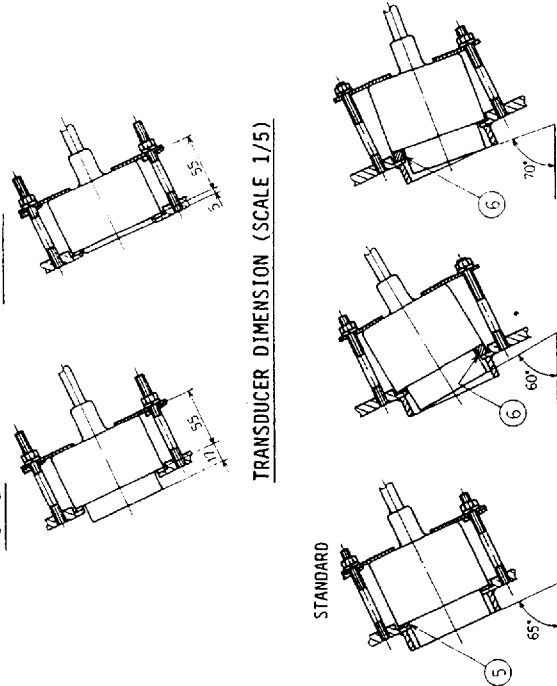
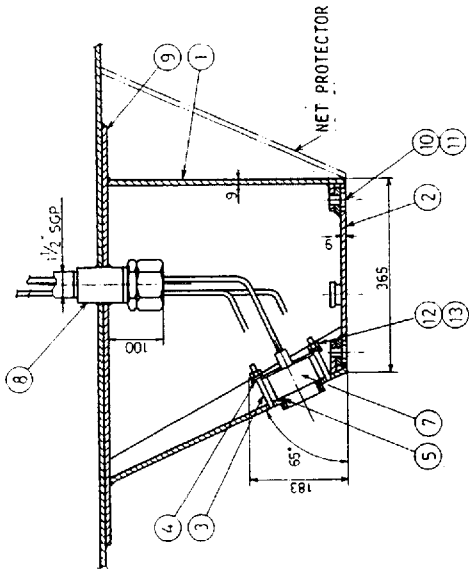
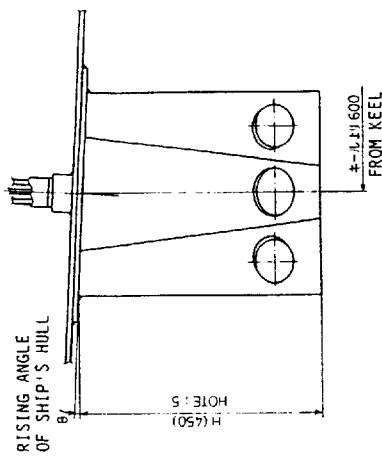

TRANSUDER DIMENSION (SCALE 1/5)

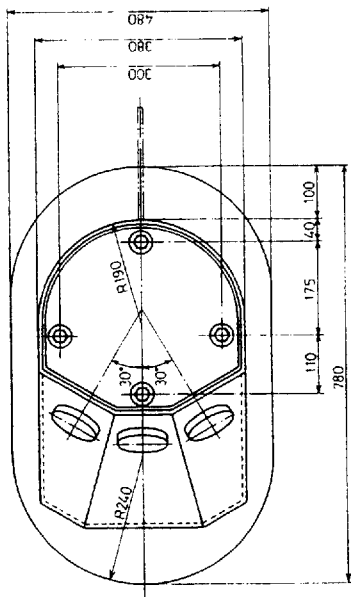

|   |   |                        |         |    |          |                      |
|---|---|------------------------|---------|----|----------|----------------------|
| 1 | 3 | SPRING WASHER          | SUS304  | 6  |          |                      |
| 1 | 2 | HEX NUT (M6)           | SUS304  | 12 |          |                      |
| 1 | 1 | SPRING WASHER          | SUS304  | 4  |          |                      |
| 1 | 0 | HEX BOLT (M12)         | SUS304  | 4  |          | SHIPYARD SUPPLY      |
| 9 |   | DOUBLING               |         | 1  |          |                      |
| 8 |   | THRU-HULL PIPE No. 7   |         | 1  | TFB-7000 |                      |
| 7 |   | 50KHZ TRANSUDER        |         | 3  |          | 50B-6 WITH LSM CABLE |
| 6 |   | ANGLE ADJUSTING PLATE  | SS 41   | 13 | T-207-06 |                      |
| 5 |   | ANGLE ADJUSTING PLATE  | SS 41   | 3  | T-207-05 |                      |
| 4 |   | TRANSUDER FIXING PLATE | SS 41   | 3  | T-207-04 |                      |
| 3 |   | TRANSUDER FIXING BOLT  | SUS304  | 6  | T-207-03 |                      |
| 2 |   | BOTTOM FLANGE          | SS 41   | 1  | T-228-02 |                      |
| 1 |   | TRANSUDER TANK         | SM 41 A | 1  | T-228-01 |                      |

|                                 |          |                                                   |          |                                 |          |
|---------------------------------|----------|---------------------------------------------------|----------|---------------------------------|----------|
| 承認<br>APPROVED                  | MA/12.87 | 承認<br>CHECKED                                     | MA/12.87 | 製<br>DRAWN                      | MA/12.87 |
| 承 認<br>APPROVED                 |          | 後 認<br>CHECKED                                    |          | 製 認<br>DRAWN                    |          |
| T. TAKAKI                       |          | T. Koda                                           |          | T. Koda                         |          |
| MAY. 12. 87                     |          | MAY. 12. 87                                       |          | MAY. 12. 87                     |          |
| 70 kg                           |          | 70 kg                                             |          | 70 kg                           |          |
| F2001-137-D                     |          | F2001-137-D                                       |          | F2001-137-D                     |          |
| 名 稱<br>TITLE                    |          | HULL BOTTOM INSTALLATION OF NET-RECORDER RECEIVER |          |                                 |          |
| 材 質<br>MATERIAL                 |          | 材 質<br>MATERIAL                                   |          | 材 質<br>MATERIAL                 |          |
| 品 名<br>NAME                     |          | 品 名<br>NAME                                       |          | 品 名<br>NAME                     |          |
| 品 番<br>ITEM                     |          | 品 番<br>ITEM                                       |          | 品 番<br>ITEM                     |          |
| 三 角 法<br>THIRD ANGLE PROJECTION |          | 三 角 法<br>THIRD ANGLE PROJECTION                   |          | 三 角 法<br>THIRD ANGLE PROJECTION |          |
| R 度<br>SCALE                    |          | R 度<br>SCALE                                      |          | R 度<br>SCALE                    |          |
| 備 註<br>REMARKS                  |          | 備 註<br>REMARKS                                    |          | 備 註<br>REMARKS                  |          |

- NOTE:
- Decide principal items after discussing with ship owner or dockyard.
  - If necessary net protector and/or protection tank should be made by shipyard.
  - The position of thru-hull pipe should be specified so that it gives some clearance from hull frames to facilitate cap-nut fastening job. Also ensure that pipe does not hit or contact the transducers.
  - Transducer tilt angle can be changed from 65 degrees (standard) to 60 or 70 degrees by use of angle adjusting plates.
  - The tank height "H" should be adjusted so that the transducer beam may not be obstructed with keel and air bubbles. If height of supplied tank is insufficient, add it locally.

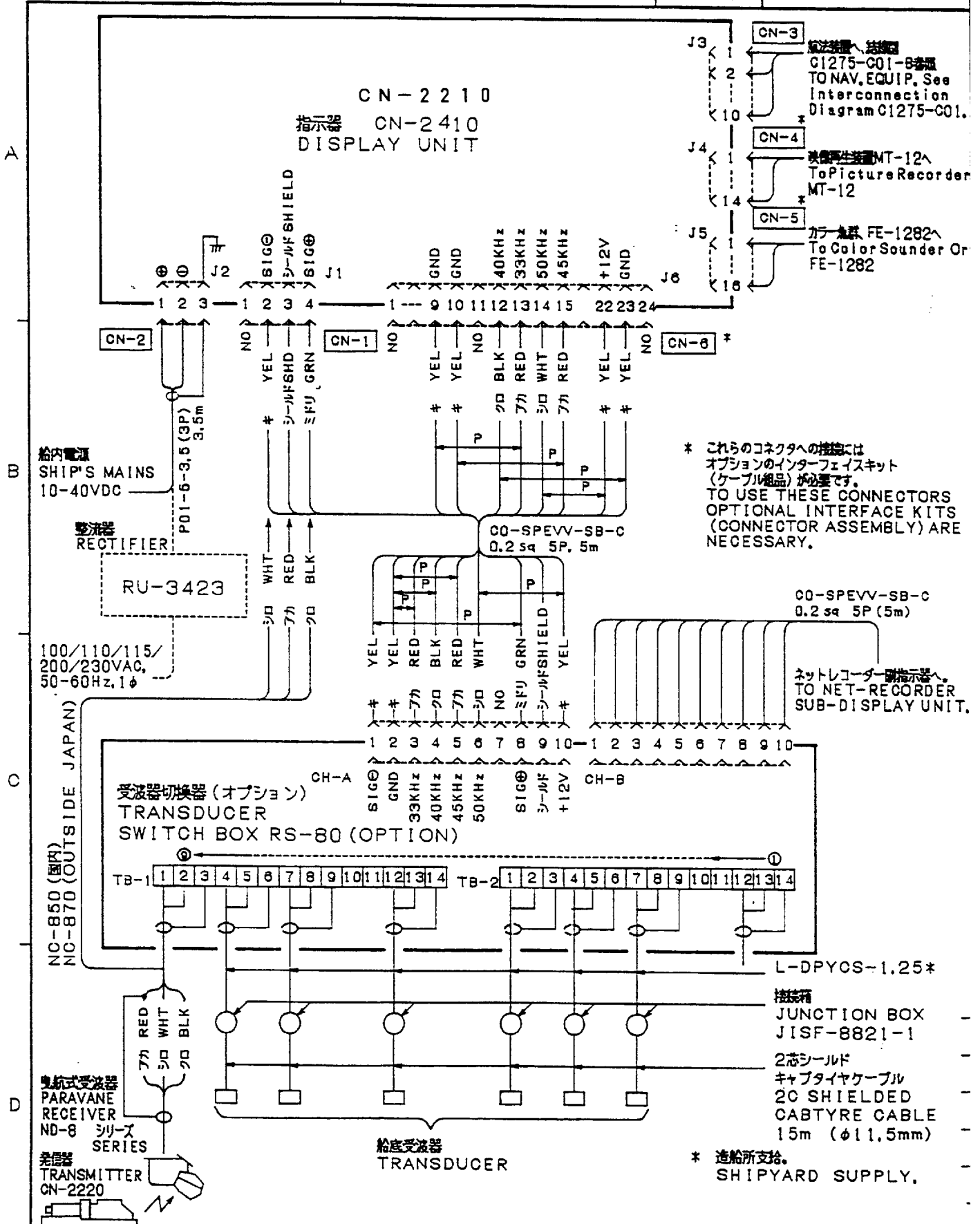

|                                      |              |                            |
|--------------------------------------|--------------|----------------------------|
| DRAWN<br>Aug. 1 '76<br>Y. EBISU      |              | TYPE<br>CN-22/24           |
| CHECKED<br>Aug. 1 '76<br>K. Kusunoki |              | 名称<br>カラーネットレコーダー          |
| APPROVED<br>Aug. 2 '76<br>K. Ota     | CN-22/24     | 相互結線図                      |
| SCALE<br>X                           | MASS<br>- kg | APPLICABLE TO:<br>(MODEL)  |
| DWG NO.<br>C1284-C01-C               | BLOCK NO.    | NAME<br>COLOR NET RECORDER |
| INTERCONNECTION DIAGRAM              |              |                            |

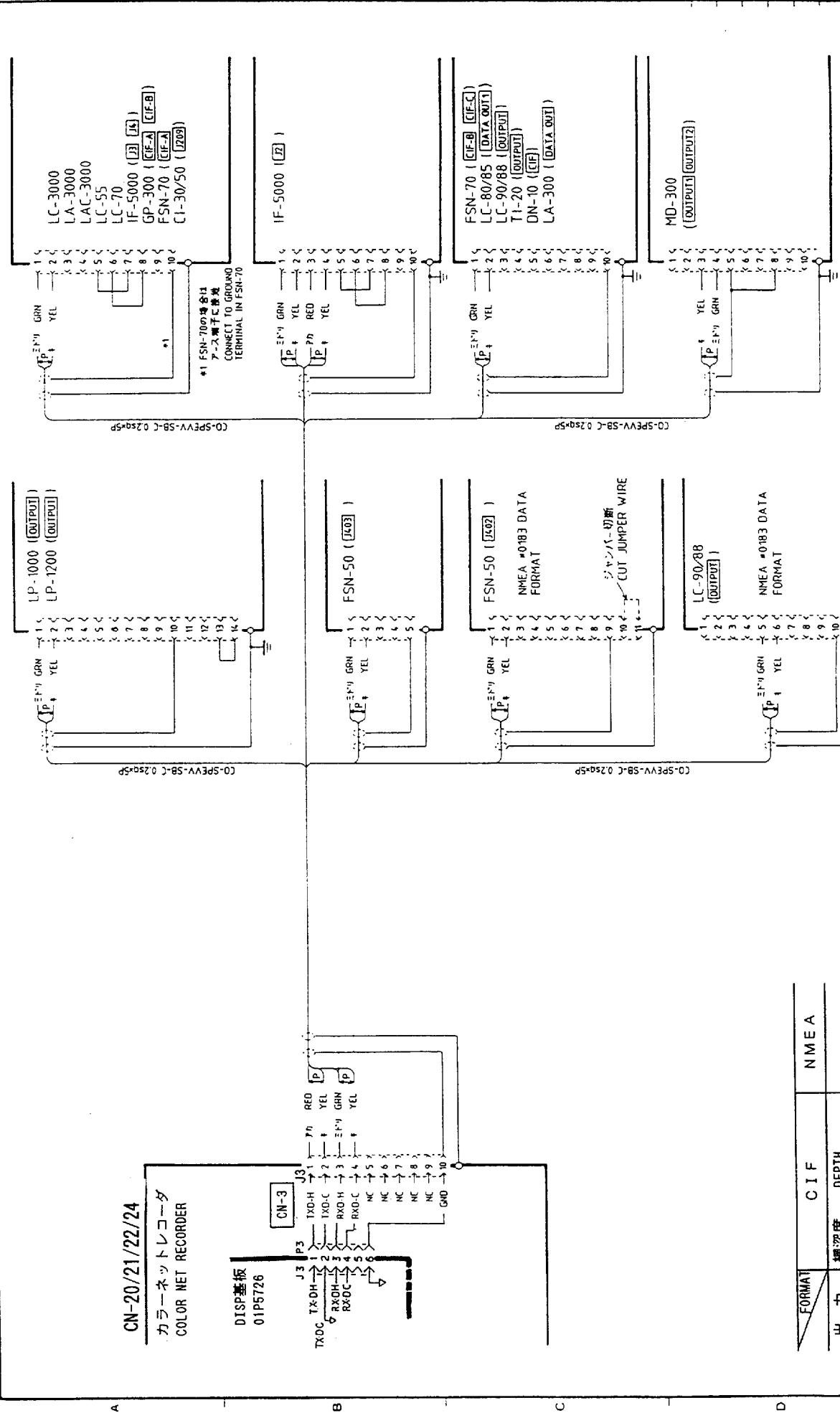

CN-20/21/22/24  
カラーネットレコーダ  
COLOR NET RECORDER

DISP基板  
01P5726

|                |                            |                                           |                                |
|----------------|----------------------------|-------------------------------------------|--------------------------------|
| 承認<br>APPROVED | MAR. 30. '96<br>T. NAKAZUO | 名称<br>TITLE                               | CN-20/21/22/24 - 航法装置<br>相互結線図 |
| 検閲<br>CHECKED  | MAR. 30. '96<br>H. USUDA   | 色別<br>COLOR NET RECORDER - NAV. EQUIPMENT | INTERCONNECTION DIAGRAM        |
| 図面<br>DRAWN    | MAR. 30. '96<br>T. MIYOSH  | 図番<br>DWG. NO.                            | C1275-C01-D                    |

| 出力<br>OUTPUT          | C I F | NMEA                  |
|-----------------------|-------|-----------------------|
| 網深度<br>DEPTH          |       |                       |
| 網口水温<br>NET. TEMP     |       |                       |
| 緯度・経度<br>L/L          |       | 左に同じ<br>Same as left. |
| 船速<br>Ship's speed    |       |                       |
| コース<br>Ship's bearing |       |                       |
| 時刻<br>Time            |       |                       |

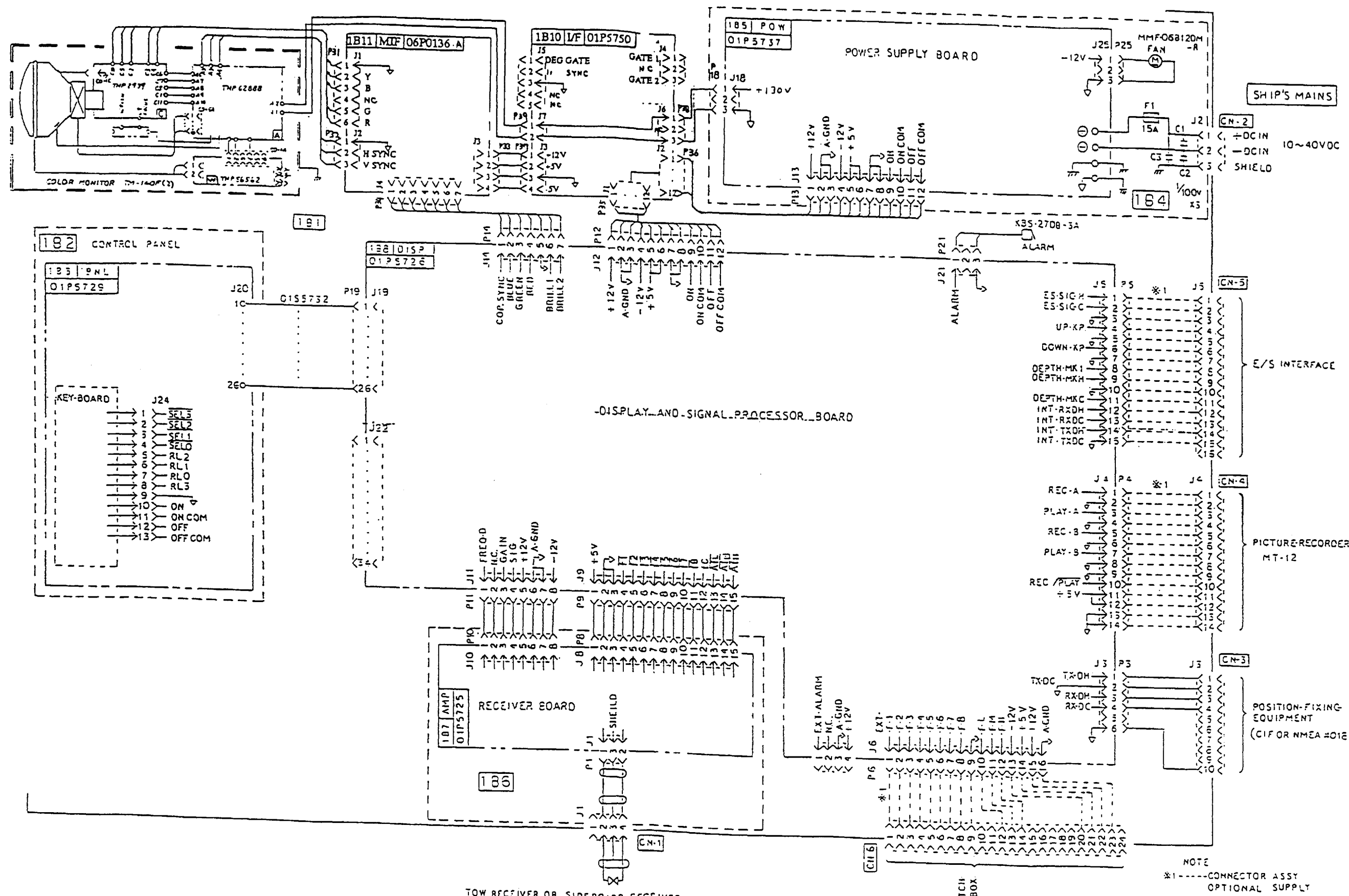

A

B

C

|         |    |       |      |
|---------|----|-------|------|
| 変更通知書番号 | 符号 | 訂正年月日 | 訂正内容 |
|         | △  |       |      |
|         | △  |       |      |
|         | △  |       |      |
|         | △  |       |      |

|                                                                                            |                               |
|--------------------------------------------------------------------------------------------|-------------------------------|
| DRAWN JULY 30 '96<br>CHECKED<br>July 30 '96 K Okamoto<br>APPROVED<br>July 30 '96 K Okamoto | TYPE<br>名称<br>指示器接合<br>回路図    |
| SCALE / MASS                                                                               | APPLICABLE TO: BLOCK NO. NAME |

TOW RECEIVER OR SIDEBOARD RECEIVER

NOTE  
\*1 --- CONNECTOR ASSY  
OPTIONAL SUPPLY

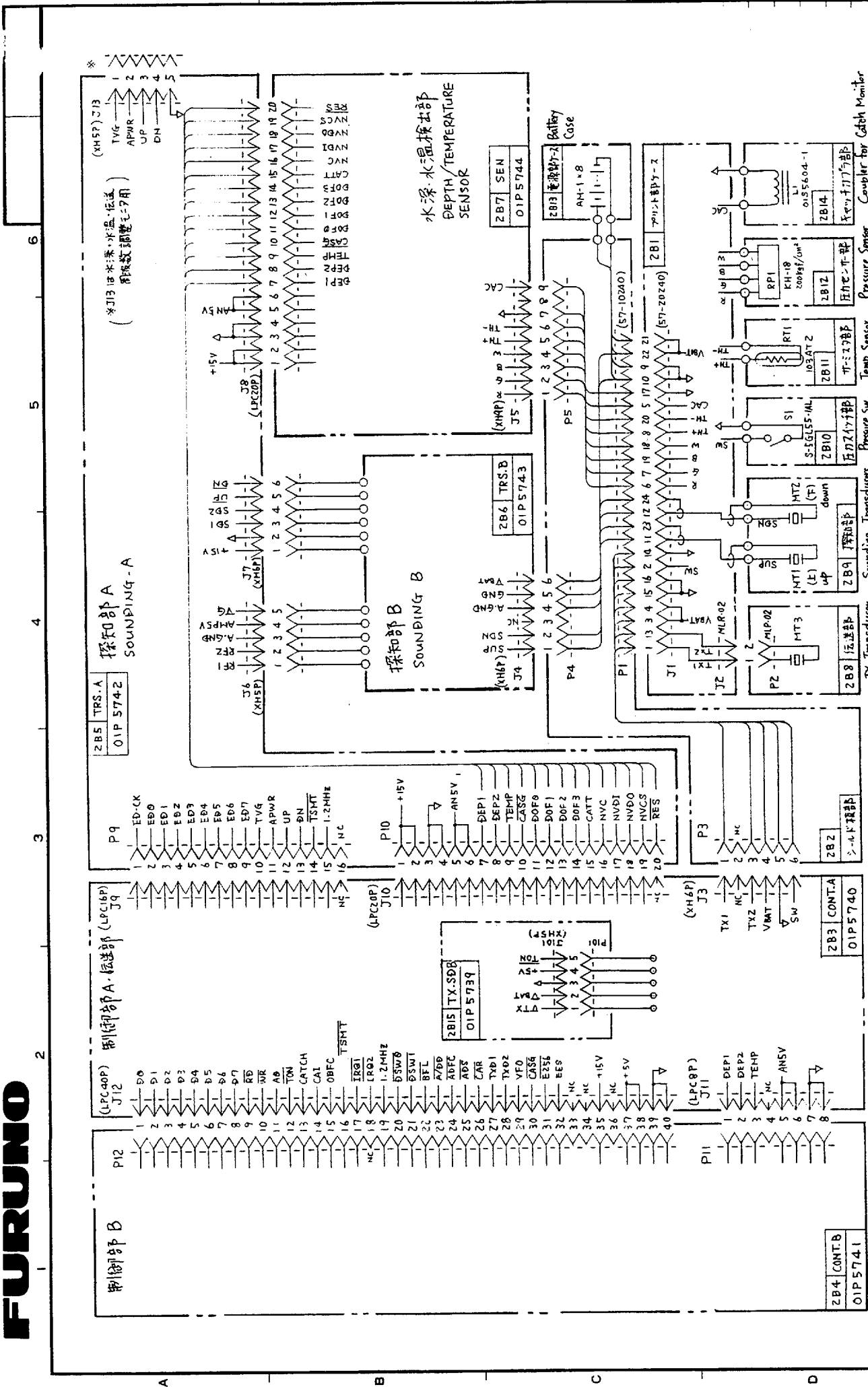

|                |                          |                 |                                             |
|----------------|--------------------------|-----------------|---------------------------------------------|
| 承認<br>APPROVED | SEP. 7. 91<br>T. NAKAJIO | 名 称<br>TITLE    | 発信器総回路図<br>TRANSMITTER<br>SCHEMATIC DIAGRAM |
| 検閲<br>CHECKED  | SEP. 9. 91<br>H. USUDA   | 図 番<br>DWG. NO. | CN-22/24                                    |
| 製 図<br>DRAWN   | SEP. 5. 91<br>T. MIYOSHI |                 | C1284-K01-C                                 |