

FURUNO

OPERATOR'S MANUAL

NAVTEX RECEIVER

MODEL NX-500

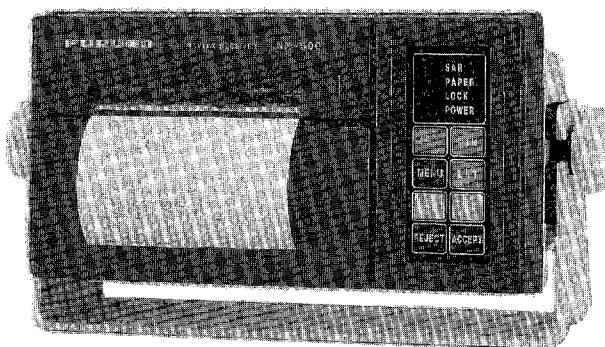

FURUNO ELECTRIC CO., LTD.
NISHINOMIYA, JAPAN

©FURUNO ELECTRIC CO., LTD.

9-52, Ashihara-cho,
Nishinomiya, Japan 662

Telephone: 0798-65-2111
Telefax: 0798-65-4200

•Your Local Agent/Dealer

All rights reserved. Printed in Japan

FIRST EDITION : JUN 1989
T : NOV. 5, 1999

(TATA)

PUB. No. OME-55090
NX-500



86%



SAFETY INSTRUCTIONS

"**DANGER**", "**WARNING**" and "**CAUTION**" notices appear throughout this manual. It is the responsibility of the operator and installer of the equipment to read, understand and follow these notices. If you have any questions regarding these safety instructions, please contact a FURUNO agent or dealer.



DANGER

This notice indicates a potentially hazardous situation which, if not avoided, will result in death or serious injury.



WARNING

This notice indicates a potentially hazardous situation which, if not avoided, could result in death or serious injury.



CAUTION

This notice indicates a potentially hazardous situation which, if not avoided, could result in minor or moderate injury, or property damage.



SAFETY INFORMATION FOR THE OPERATOR

WARNING



Do not open the cover of the equipment.

This equipment uses high voltage electricity which can shock, burn. Only qualified personnel should work inside the equipment.

Do not disassemble or modify the equipment.

Fire, electrical shock or serious injury can result.

Immediately turn off the power at the ship's mains switchboard if water or foreign object falls into the equipment or the equipment is emitting smoke or fire.

Continued use of the equipment can cause fire, electrical shock or serious injury.

CAUTION

Do not place liquid-filled containers on the top of the equipment.

Fire or electrical shock can result if a liquid spills into the equipment.

Do not place heater near the equipment.

Heat can melt the power cord, which can result in fire or electrical shock.

Do not operate the unit with wet hands.

Electrical shock can result.

Use the correct fuse.

Use of the wrong fuse can cause fire or equipment damage.

SAFETY INFORMATION FOR THE INSTALLER

⚠ WARNING

 Only qualified personnel should work inside the equipment.

This equipment uses high voltage electricity which can shock, burn, or cause death.

Turn off the power at the ship's mains switchboard before beginning the installation. Post a warning sign near the switchboard to ensure that the power will not be applied while the equipment is being installed.

Serious injury or death can result if the power is not turned off, or is applied while the equipment is being installed.

⚠ CAUTION

 **Ground the equipment.**

Ungrounded equipment can give off or receive electro-magnetic interference or cause electrical shock.

Confirm that the power supply voltage is compatible with the voltage rating of the equipment.

Connection to the wrong power supply can cause fire or equipment damage. The voltage rating appears on the label at the rear of the equipment.

Observe the compass safe distances to prevent deviation of a magnetic compass.

Unit	Standard compass	steering compass
NX-500	0.8 m	0.6 m

A WORD TO NX-500 OWNERS

Congratulations on your choice of the FURUNO NX-500 NAVTEX Receiver. We are confident that you will enjoy many years of operation with this fine piece of equipment.

For over 40 years Furuno Electric Company has enjoyed an enviable reputation for quality and reliability throughout the world. This dedication to excellence is furthered by our extensive global network of agents and dealers.

The NX-500 is just one of the many Furuno developments in the field of marine radio communication. Employing many of the features of our best selling NAVTEX Receiver-equipped Facsimile Receiver models FAX-208A/288 and FAX-214, the NX-500 provides cost-effective price, high sensitivity and simple operation in one compact and light-weight unit, making it the perfect match for any class of vessel. In addition to its fundamental function of receiving NAVTEX broadcasts, this unit can also function as a data logger (navigation aid and interface kit required), printing out navigation data on command.

This unit is designed and constructed to ensure the user of many years of trouble-free operation. To obtain full performance from the equipment, however, you should carefully read and follow the recommended procedures for installation, operation and maintenance. No machine can perform its intended functions unless it is installed and maintained properly.

Thank you for considering and purchasing FURUNO equipment.

TABLE OF CONTENTS

	<u>PAGE</u>
SAFETY INSTRUCTION	i
INTRODUCTION	viii
1. PRINCIPLE OF NAVTEX SYSTEM	1-1 thru 1-6
Navtex Station Map	1-4
Navtex Station List	1-5
2. OPERATION	2-1 thru 2-18
Command Hierarchy	2-1
Front Panel	2-2
Reception of Navtex Broadcast	2-4
User Setting	2-7 thru 2-13
Menu-A: Set station	2-8
Menu-B: Set message	2-8
Menu-C: Set function	2-10
Menu-D: Print received ID	2-11
Menu-E: Print status	2-12
Menu-F: Print NMEA(or CIF) data	2-13
User Setting for Printout of Navigation Data	2-14 thru 2-18
Selection of navigation data to be printed	2-14
Selection of talker for each navigation data	2-14
Set position talker	2-15
Set speed talker	2-16
Set bearing talker	2-16
Set print interval	2-17
Set print start time	2-17
3. REPLACEMENT OF THERMAL PAPER	3-1
4. MAINTENANCE	4-1
Periodic Inspection	4-1
Fuse Replacement	4-1
5. TROUBLESHOOTING	5-1 thru 5-3
Operator Troubleshooting	5-1
System Diagnosis	5-2

6. INSTALLATION	6-1 thru 6-12
General Mounting Considerations	6-1
Main Unit Installation	6-2
Tabletop/Bulkhead Mount	6-2
Flush Mount	6-3
Antenna Installation	6-4
Passive Antenna	6-4
Active Antenna	6-5
Cable Connections	6-6
Power Cable	6-6
Antenna Cable	6-6
Grounding Wire	6-8
Initial Setting	6-8
External Connections	6-9
External Input/Output	6-9
SAR Alarm	6-9
AF Out/Input	6-10
Navigation Data	6-10
List of Furuno Equipment to be connected	6-12
7. SPECIFICATIONS	7-1 thru 7-5
Specifications	7-1
Complete Set	7-3
At-sea Maintenance Parts	7-5
System Diagram	D-1
Outline Drawings	D-1 thru D-4
Main Unit (NX-500)	D-2
Preamp Unit (NX-5)	D-3
1.2m Whip Antenna	D-4
Exploded View and Parts List	D-5
Block Diagram	D-6
Schematic Diagrams	S-1 thru S-3
Main Unit, General	S-1
Power Board	S-2
TB Board	S-3
APPENDIX A. COMMAND HIERARCHY	APA-1
APPENDIX B. SUMMERY OF USER SETTING	APB-1
APPENDIX C. IMPROVEMENT OF RECEIVER S/N RATIO	APC-1
Declaration of conformity to type	

INTRODUCTION

NAVTEX (Navigational Telex) is a worldwide coastal telex broadcasting system. Coastal NAVTEX broadcasting stations with specific ID's transmit Navigational warnings, Meteorological warnings, Search and Rescue (SAR) information and other navigational information for NAVTEX receiver-equipped vessels sailing in coastal waters.

The FURUNO NX-500 NAVTEX receiver receives NAVTEX messages and automatically prints them out together with station ID and message category information.

The service range of a NAVTEX station is typically 200-400 nautical miles and normally it broadcasts every 4 hours.

The NAVTEX message is relevant for all types and sizes of vessels. The NX-500 is shipped from the factory equipped to receive all types of NAVTEX messages from all NAVTEX stations. However, if the vessel operates within a specific area only, unnecessary stations can be rejected by the "manual station selection" facility.

If ship's position data is fed from navigation equipment (optional connector kit required), the NX-500 automatically decides in which NAVAREA (Geographical zones defined by International Maritime Organization. Refer to page 1-1.) the vessel is navigating, and selects only stations belonging to the relevant NAVAREA.

In addition to NAVTEX message reception, the NX-500 can function as a "data logger" for navigation equipment without interrupting the NAVTEX reception. Navigation data such as position, speed and heading can be printed automatically at a specified time interval or manually on command.

FEATURES

- Meets SOLAS requirements (SOLAS Convention ship are required to carry a NAVTEX receiver not later than Aug. 1, 1993.)
- Advanced thermal printer provides noiseless, dust-free, odor-free operation.
- Crisp, clean printout on high quality thermal paper.
- Optionally available preamp unit w/1.2m whip antenna is perfect for installation where antenna space is limited.
- Unattended operation once required data are entered.
- Printing is stopped automatically when the percentage of printing error exceeds 33%.
- Universal power supply from 10.8V-40V, drawing less than 15W (at 24V.)
- Memory of up to 64 ID's for last 66 hours.
- Navigation data can be fed through external input (connection with navigation aid required) and printed out when required.

1. PRINCIPLE OF NAVTEX SYSTEM

HOW NAVTEX WORKS

There are many types of navigational and meteorological information available on radio, such as NAVAREA, HYDROPAC, etc. However, these systems rely heavily upon the operator's experience and skill in tuning the radio and interpreting messages. In addition, constant monitoring to pick up wanted information among a vast volume of messages is not practical with a limited radio staff.

To provide all mariners with up-to-the minute information automatically, the Navtex system was developed.

NAVTEX is an acronym meaning Navigational Telex, and as its name shows, it is a kind of narrow band radio teletype system for sending (by frequency shift keying) text messages expressed in a 7-unit code. The difference is that a Navtex transmitter transmits nine control characters (header code) ahead of the main message, so that the receiver can identify the station, message type and serial number automatically.

NAVTEX SYSTEM OPERATION

For navigation purposes, the world is divided into 16 areas as shown in the figure below. Each Navtex station has an identification code, from "A" to "Z." The frequency assigned to Navtex is only one (518kHz), and many stations exist in the same service coverage.

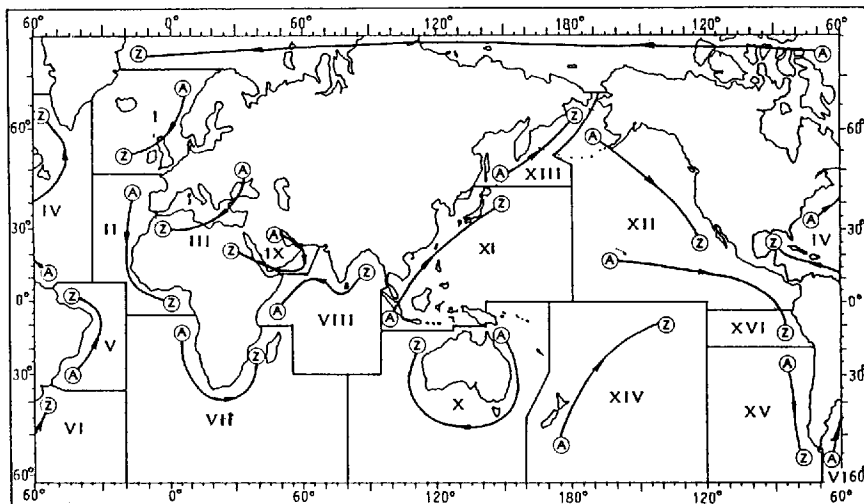

If the stations were to transmit without any rule, the system would collapse due to mutual interference. To avoid this problem, the following rules apply.

- The transmission schedule is determined so that two or more stations having a common service area may not overlap in time.
- Each station transmits with minimum required power to cover its service area (200 nautical miles nominal).

The table shows the transmission time schedule in Navarea I.

Reykjavik (R)		0318		0718		1118		1518		1918		2318
Scheveningen (P)			0348		0748		1148		1548		1948	2348
Stockholm (J)			0330		0730		1130		1530		1930	2330
Oostend (T)			0248		0648			1248			1848	2248
Rogoland (L)			0148		0548		0948		1348		1748	2148
Brest le C. (F)			0118		0518		0918		1318		1718	2118
Cullercoast (G)			0048		0448		0848			1648		2048
Tallin (U)			0030		0430		0830		1230		1630	2030
Haernoensand (H)			0000		0400		0800		1200		1600	2000
Bodo (B)			0018		0418		0818		1218		1618	2018

MESSAGE FORMAT

For automatic identification of messages, each message starts with nine control characters, called "Header codes."

The first five characters are always "ZCZC--" and common to all messages. This part is used for message synchronization. The latter four characters are designated as b1, b2, b3 and b4 indicate origin, category and serial number of the message.

Character b1 is the identification letter of the Navtex station; "A" thru "Z." Character b2 indicates the type of message, "A" thru "Z," as listed in the following page. Character b3 and b4 indicate the serial number of the message. The serial numbers are counted up from "01" to "99," and starts from "01" again. Number "00" is specially reserved for important emergency messages, such as a search and rescue (SAR) message.

The end of each message is indicated by "NNNN" (four successive N's).

General message format is summarized below.

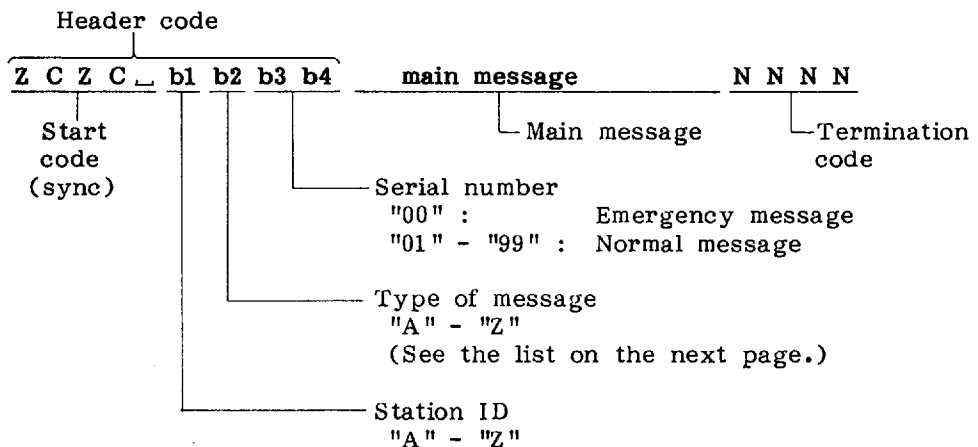

[Type of message (category)]

A:	Navigational warnings	I:	OMEGA messages
B:	Meteorological warnings	J:	SATNAV messages
C:	Ice reports	K:	Other electronic navaid messages (Messages concerning radio- navigation services)
D:	Search and Rescue information	L:	Navigational warnings-additional to letter A
E:	Meteorological forecasts	M thru Y:	No category assigned
F:	Pilot service messages	V thru Y:	Special services-allocation by IMO
G:	DECCA messages	Z:	No message on hand
H:	LORAN messages		

MESSAGE HANDLING IN NAVTEX RECEIVER

The NAVTEX RECEIVER acquires, stores and prints Navtex messages according to the following rules.

1. Selectively acquires stations and types of messages specified by the operator. Message types A, B and D can not be switched off by the operator.
2. Message type D (search and rescue information) is an "SAR" message and will be printed immediately. To call this to the operator's attention, the alarm buzzer sounds and the "SAR" warning LED lights.
3. When an abnormal character is received due to noise interference, it will be printed as "*" (asterisk).
4. Message type D (search and rescue information) will be reprinted.
(Reprinting can be inhibited by presetting.)
5. Message having serial no. 00 (emergency message) will be reprinted.
6. Message types A,B, D&L or serial no. 00 from rejected stations will be printed.
(Printing of message type A from rejected stations can be inhibited by presetting.)
7. Message type D will be printed up to 2000 characters regardless of character error rate.
(The NX-500 can be preset to stop printing when the error rate is over 33%.)

NAVTEX STATION MAP

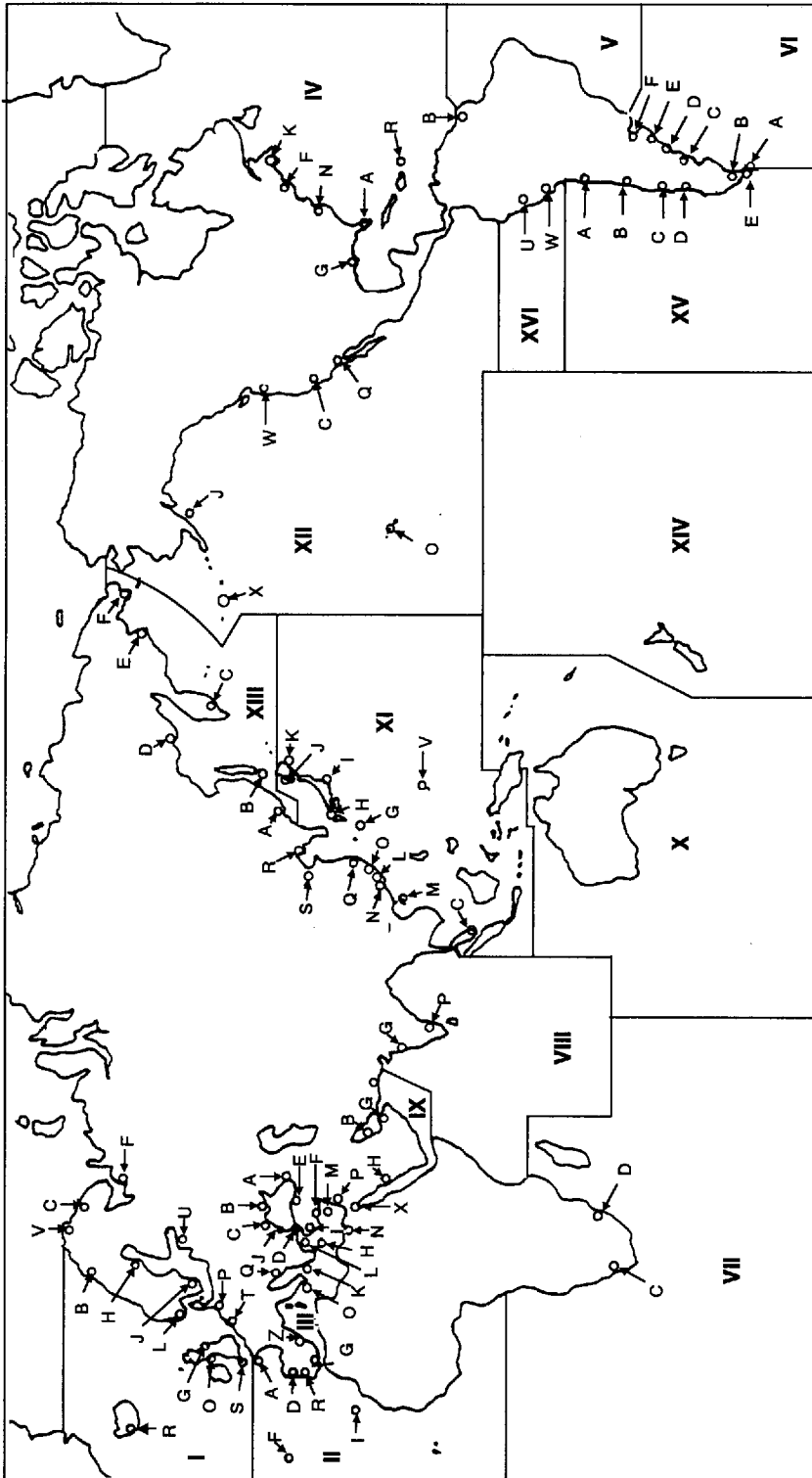

NAVTEX STATION LIST

Nav-area	Stn ID	Country	City	Time Schedule (UTC)	Remarks
I	B	NORWAY	Bodo	0018, 0418, 0900, 1218, 1618, 2100	Pre-operational
	C	RUSSIA	Murmansk	0120, 0520, 0920, 1320, 1720, 2120	
	F	RUSSIA	Arkhangelsk	0200, 0600, 1000, 1400, 1800, 2200	
	G	U.K.	Cullercoats	0048, 0448, 0848, 1248, 1648, 2048	
	H	SWEDEN	Haernoessand	0000, 0400, 0800, 1200, 1600, 2000	
	J	SWEDEN	Stockholm	0300, 0730, 1130, 1530, 1930, 2330	
	L	NORWAY	Rogaland	0148, 0548, 0948, 1348, 1748, 2148	
	O	U.K.	Portpatrick	0130, 0530, 0930, 1330, 1730, 2130	
	P	NETH. L	Scheveningen	0348, 0748, 1148, 1548, 1948, 2348	
	R	ICELAND	Reykjavik	0318, 0718, 1118, 1518, 1918, 2318	
	S	U.K.	Niton	0018, 0418, 0900, 1218, 1618, 2100	
	T	BELGIUM	Oostende	0248, 0648, 1048, 1448, 1848, 2248	
U	RUSSIA	Tallin	0030, 0430, 0830, 1230, 1630, 2030		
V	NORWAY	Vardoe	0300, 0700, 1100, 1500, 1900, 2300		
II	A	FRANCE	Brest-Le conq	0030, 0430, 0830, 1230, 1630, 2030	Planned
	D	SPAIN	Finisterre		
	F	PORTUGAL	Azores		0050, 0450, 0850, 1250, 1650, 2050
	I	SPAIN	Canary Islands		0100, 0500, 0900, 1300, 1700, 2100
R	PORTUGAL	Lisbon	0250, 0650, 1050, 1450, 1850, 2250	Planned	
		CAMEROON	Douala		
III	A	RUSSIA	Novorossiysk	0300, 0700, 1100, 1500, 1900, 2300	Planned
	B	RUSSIA	Mariupol	0100, 0500, 0900, 1300, 1700, 2100	
	C	RUSSIA	Odessa	0230, 0630, 1030, 1430, 1830, 2230	
	D	TURKEY	Istanbul	0030, 0430, 0830, 1230, 1630, 2030	
	E	TURKEY	Samsun	0040, 0440, 0840, 1240, 1640, 2040	
	F	TURKEY	Antalya	0050, 0450, 0850, 1250, 1650, 2050	
	G	SPAIN	Tarifa	0100, 0500, 0900, 1300, 1700, 2100	
	H	GREECE	Iraklion	0110, 0510, 0910, 1310, 1710, 2110	
	I	TURKEY	Izmir	0120, 0520, 0920, 1320, 1720, 2120	Planned
	J	BULGARIA	Varna	0130, 0530, 0930, 1330, 1730, 2130	
	K	GREECE	Kerkyra	0140, 0540, 0940, 1340, 1740, 2140	
	L	GREECE	Limnos	0150, 0550, 0950, 1350, 1750, 2150	
	M	CYPRUS	Troodos	0200, 0600, 1000, 1400, 1800, 2200	
	N	EGYPT	Alexandria	0210, 0610, 1010, 1410, 1810, 2210	
	O	MALTA	Malta	0220, 0620, 1020, 1420, 1820, 2220	
	P	ISRAEL	Haifa	0020, 0420, 0820, 1220, 1620, 2020	
Q	YUGO.	Split	0250, 0650, 1050, 1450, 1850, 2250	Planned	
Z	SPAIN	Cabo La Nao			
		FRANCE	La Garde		
IV	A	USA	Miami	0000, 0600, 1200, 1800	Pre-operational
	B	BERMUDA	St. Georges	0100, 0700, 1300, 1900	
	F	USA	Boston	0445, 1045, 1645, 2245	
	G	USA	New Orleans	0300, 0900, 1500, 2100	Under trials
	K	CANADA	Sydney	0040, 0540, 0940, 1340, 1740, 2140	
	N	USA	Portsmouth	0130, 0730, 1330, 1930	
R	USA	San Juan	0415, 1015, 1615, 2215	Pre-operational	

Nav-area	Stn ID	Country	City	Time Schedule (UTC)	Remarks
V		URUGUAY URUGUAY URUGUAY URUGUAY URUGUAY	Colonia Laguna D Sauce La Paloma Montevideo Punta de Este Salto		Planned Planned Planned Planned Planned
VI	A B C D E F G	ARGENTINA ARGENTINA ARGENTINA ARGENTINA ARGENTINA ARGENTINA ARGENTINA	Ushuaia Rio Gallegos Rivadavia Bahia Blanca Mar Del Plata Buenos Aires Rosario	0240, 0840, 1440, 2040 0140, 0740, 1340, 1940 0040, 0640, 1240, 1840 0210, 0810, 1410, 2010 0110, 0710, 1310, 1910 0510, 1110, 1710, 2310 0110, 0610, 1210, 1810	planned
VII	C D	S. AFRICA S. AFRICA	CAPETOWN DURBAN	0020, 0420, 0820, 1220, 1620, 2020 0120, 0520, 0920, 1320, 1720, 2120	
VIII	G P	INDIA INDIA	Bombay Madras	0100, 0500, 0900, 1300, 1700, 2100 0230, 0630, 1030, 1430, 1830, 2230	
IX	H G X B	S. ARABIA S. ARABIA EGYPT BAHRAIN	Jeddah Dammam Ismailia Hamala	0010, 0410, 0810, 1210, 1610, 2010	Planned Planned Planned Planned
XI	V C G H I J K L M N O R Q S	USA SINGAPORE JAPAN JAPAN JAPAN JAPAN JAPAN HONG KONG CHINA CHINA CHINA CHINA CHINA CHINA	Guam Jurong Naha Moji Yokohama Otaru Kushiro Hong Kong Zhanjiang Guangzhou Fuzhou Dalian Shanghai Tianjin Hainan	0100, 0700, 1300, 1900 0020, 0420, 0820, 1220, 1620, 2020 0100, 0500, 0900, 1300, 1700, 2100 0110, 0510, 0910, 1310, 1710, 2110 0120, 0520, 0920, 1320, 1720, 2120 0130, 0530, 0930, 1330, 1730, 2130 0140, 0540, 0940, 1340, 1740, 2140 0200, 0600, 1000, 1400, 1800, 2200 0210, 0610, 1010, 1410, 2210 0250, 0650, 1050, 1450, 2250 0240, 0640, 1040, 1440, 2240	
XII	C W Q J O X	USA USA USA USA USA USA	San Francisco Astoria Cambria Kodiak Honolulu Adak	0400, 1000, 1600, 2200 0130, 0730, 1330, 1930 0445, 1045, 1645, 2245 0300, 0900, 1500, 2100 0040, 0640, 1240, 1840 0000, 0600, 1200, 1745	Pre-operational Pre-operational Pre-operational Pre-operational Planned
XIII	A B C D E F	RUSSIA RUSSIA RUSSIA RUSSIA RUSSIA RUSSIA	Vladivostok Kholmsk Petropavlovsk Magadan Beringovskiy Providenya	0000, 0400, 0800, 1200, 1600, 2000 0010, 0410, 0810, 1210, 1610, 2010 0050, 0450, 0850 0030, 0430, 0830, 1230, 1630, 2030 0040, 0440, 0840, 1240, 1640, 2040 0050, 0450, 0850, 1250, 1650, 2050	

Nav-area	Stn ID	Country	City	Time Schedule (UTC)	Remarks
XV	A	CHILE	Antofagasta	0010, 0410, 0810, 1210, 1610, 2010	
	B	CHILE	Valparaiso		
	C	CHILE	Talcahuano		
	D	CHILE	Puerto Montt		
	E	CHILE	Magallanes		
XVI	S	PERU	Païta	0300, 0700, 1100, 1500, 1900, 2300	Planned
	U	PERU	Callao	0320, 0720, 1120, 1520, 1920, 2320	Planned
	W	PERU	Mollendo	0340, 0740, 1140, 1540, 1940, 2340	Planned

NOTE: The list above shows the stations registered with the International Frequency Registration Board (IFRB) for transmission of 518 kHz (as of Jan. 1994). Note that not all stations are operational.

2. OPERATION

COMMAND HIERARCHY

The flow chart below shows configuration of commands provided in the NX-500. It is useful if you forget at which command level you are, or if you would like to move to another user setting. Most command levels selected at Main Menu revert to the Main Menu after selecting ESCape.

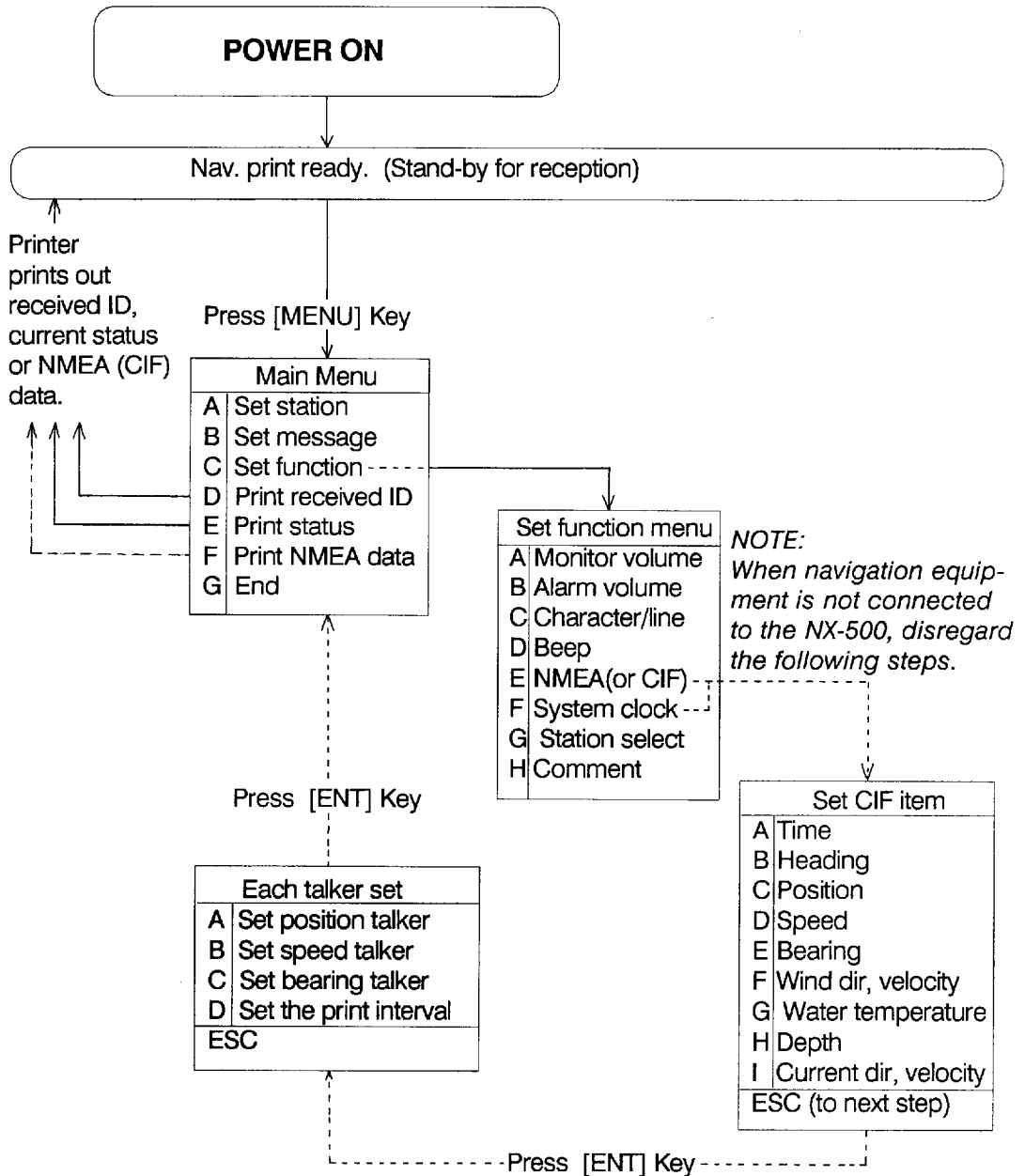

FRONT PANEL

Fig. 2-1 shows the front panel of the NX-500. All functions are controlled by eight tactile touchpad keys and one power switch, which is hidden behind the front panel to avoid accidental power cut-off. Operational status is confirmed by four LED lamps.

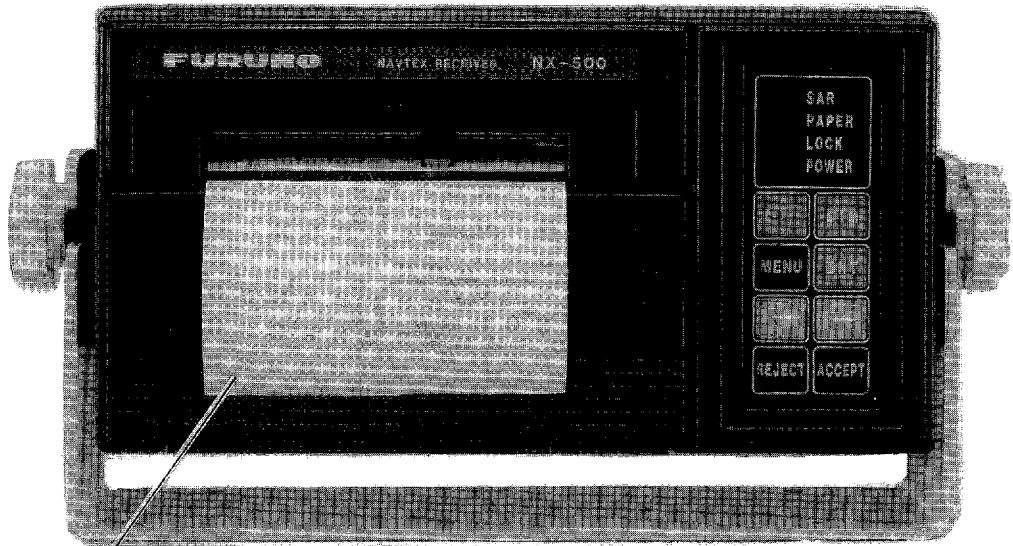

Thermal Paper

Type: TP0340
(112mm × 40m)

Code No: 000-801-765

Fig. 2-1 NX-500 Front Panel

NOTE

Before turning the power on, set the thermal paper referring to the instructions on page 3-1.

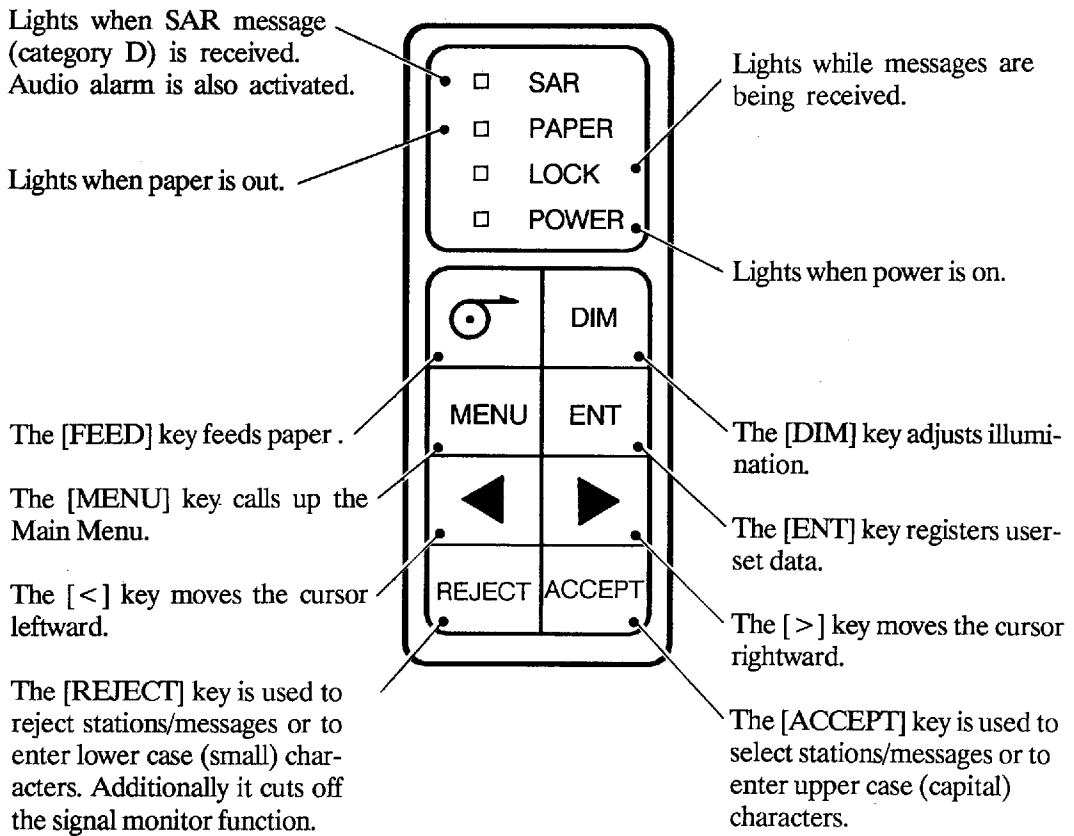

Fig. 2-2 NX-500 Control Panel

RECEPTION OF NAVTEX BROADCAST

GENERAL

Reception is simple; all you have to do is to switch on the NX-500. The NX-500 receives the NAVTEX signal and identifies station and message category.

The NX-500 rejects multiple printout of once-received messages by referring to station ID, message category and message serial number. The following messages, however, will be printed regardless of the number of times received;

- 1) Warning (categories A and B) and SAR (category D) messages.
- 2) Messages carrying serial number "00."
- 3) Messages whose rate of character error exceeds 4%.
(Refer to page 2-6 for "error rate.")

TURNING THE NX-500 ON AND OFF

Flip down the panel and turn on the power switch.

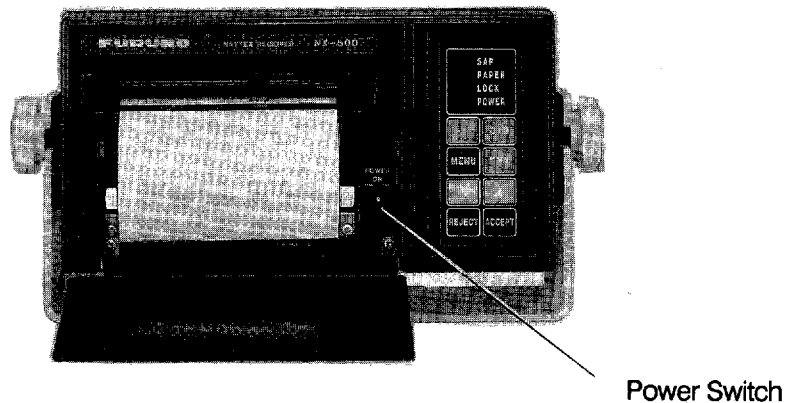

Fig. 2-3 NX-500, Panel opened to show Power Switch

As soon as the NX-500 is turned on, the message "Nav. print ready." is printed, indicating it is in stand-by, ready to receive the NAVTEX signal.

Nav. print ready.

This is the receiving mode.

NOTE: The NX-500 should be turned on for the duration of a voyage so that important warning messages will be not missed .

ADJUSTING ILLUMINATION BACKLIGHTING AND BRIGHTNESS

Paper illumination, touchpad panel backlighting and LED brightness can be adjusted concurrently with the [DIM] key. Each time the key is pressed illumination, backlighting and brightness are changed in the sequence of BRIGHT-DIM-OFF.

FEEDING THE PAPER

The [FEED] key is used to feed the paper. Each press of the key advances the paper by one line. Press and hold down the key to advance the paper more quickly. Note that the key is inoperative while a message is being printed.

SIGNAL MONITOR

The "raw" NAVTEX signal (518kHz) can be monitored through the monitor speaker. This function is useful when tuning the long-wire antenna. To monitor the NAVTEX signal, confirm that the unit is in the receiving mode, then press the [ACCEPT] key. Signal monitoring is automatically cut off after one minute, or may be cut off manually by pressing the [REJECT] key.

PRINTOUT

A NAVTEX message, an example of which is shown below, is printed once it is completely received.

```
                                (Error Rate= 0.0%)
ZCZC GA45
WZ884
DOVER STRAIT
CABLE LAYING OPERATIONS IN PROGRESS BETWEEN FOLKSTONE AND SANGATTE
CABLE VESSELS LOCATED IN ENGLISH AND FRENCH IN SHORE TRAFFIC ZONES
DETAILS IN REGULAR BROADCASTS BY CHANNEL NAVIGATION SERVICE.
NNNN
```

Printout by 70
characters/line
(default setting)

```
                                (Error Rate= 0.0%)
ZCZC GA45
WZ884
DOVER STRAIT
CABL LAYING OPERATIONS IN PROGRESS
BETWEEN FOLKSTONE AND SANGATTE
CABLE VESSELS LOCATED IN ENGLISH A-
ND FRENCH IN SHORE TRAFFIC ZONES
DETAILS IN REGULAR BROADCASTS BY
CHANNEL NAVIGATION SERVICE
NNNN
```

Printout by 35
characters/line
(Change the user
setting if this type
of print is pre-
ferred. See page 2-
10.)

ZCZC----- Message header
 GA45----- G: Station ID
 A: Message category
 45: Serial number 00 thru 99;
 NNNN----- Message terminator

Error Rate means character error rate and is calculated as follows:

$$\text{Error Rate} = \frac{\text{number of erroneous characters}}{\text{total number of characters received}} \times 100 (\%)$$

(Total number of characters includes space, line feed, carriage return, etc.)

After printing is completed, control is returned to the receiving mode. Messages carrying the same station ID and message category of ones already received less than 66 hours earlier will not be printed, to avoid redundancy and paper waste. SAR messages (message category D) and messages carrying serial number 00, however, will be printed even if they are received repeatedly.

Error rate and message reception status may be added to each message. A "comment" can be added to messages by entering "H" on the Main Menu-C: Set function. The comments printed out are tabulated below;

LIST OF COMMENTS

Comment	Meanings
(Error Rate = 0.0%)	No error is found in the received messages.
(Error Rate = 33% Over)	When the character error rate exceeds 33%, NX-500 prints this comment and suspends printing. (See NOTE 2)
Corrupt Message	When the character error rate in one message exceeds 33%, the NX-500 suspends printing and the message "Corrupt Message" is printed. (See NOTE 2)

NOTE 1. When a character could not be received due to noise interference, for example, an asterisk () is printed in its place.*

2. Messages carrying message type "D" or serial number "00", are printed regardless of character error rate.

ALARM

When the NX-500 receives a message carrying type D, it generates an audible alarm. To silence the alarm, press any key.

USER SETTING

The user setting mode allows you to custom tailor the NX-500 according to your needs. You can select which category of message you wish to receive, set monitor speaker volume, specify which data are to be printed, etc.

All user settings are contained in the Main Menu. To get into the Main Menu press the [MENU] key. The printout should look something like the figure shown below.

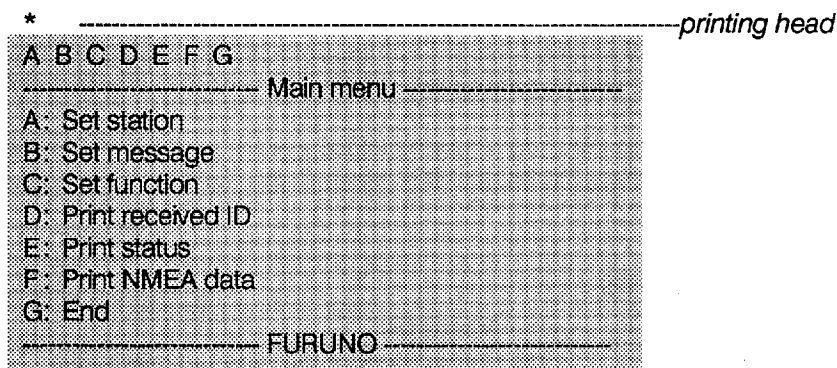

The printing head is above "A" of "A B C D E F G." Each character corresponds to a Main Menu, which is listed below them on the printout. To call up a menu, place the printing head above the letter corresponding to the menu desired by operating the arrow keys ([<], [>]) and press the [ENT] key or [ACCEPT] key.

Most functions are selected or deselected by designating upper (capital) or lower (small) case characters by pressing the [ACCEPT] key or [REJECT] key at relevant characters, respectively.

The [>] and [<] keys move the printing head rightward or leftward to skip over functions or items which you do not wish to change.

To escape from the user setting mode (at this stage), place the printing head above "G" and press either the [ENT] key or the [ACCEPT] key. The message "Nav. print ready." is displayed, indicating control is returned to the receiving mode.

The image shows a rectangular box containing the text "Nav. print ready." in a monospaced font.

- NOTE:**
1. Menus D,E and F are not for parameter setting but for activating the printer for use as a data logger.
 2. Any message received during user setting (LOCK lamp lights) is stored in the memory and will be printed out immediately after "Nav. print ready." is printed.

Menu- A: Set station

This menu allows you to select what stations you wish to receive. In order to select stations, you have to switch the reception mode to "Manual" in Menu-C: Set function. If you attempt to proceed the "Set station" menu while in the "Auto" station selection mode, the NX-500 will print the following alert message.

```
Change to manual selection mode and
try again.
```

To change the station selection mode, go to "Set function Menu-C" and switch it to "Manual" selection mode.

Procedure

- 1) Move the printing head to "A," then press either the [ENT] key or the [ACCEPT] key. The following is printed ;

```
* -----printing head
A b C D e f G H I j K L M ESC -----current setting
-----
                Set station
Selected station = capital letter
-----
ESC: ESCAPE
-----
                FURUNO -----
```

- 2) The characters in the top line of the menu represent station ID's, and may be in upper or lower case depending on prior setting. In the example, stations A, C, D, G, H, I, K, L and M are selected for reception, and stations b, e, f and j are eliminated from reception.
- 3) To select or deselect a station, place the printing head above the letter (station ID) and press [ACCEPT] or [REJECT] depending on whether you want to select or deselect the station.

If you enter the wrong character case, place the printing head above the character once again and press [ACCEPT] (or [REJECT]) key. The incorrect character case is overwritten. After all changes are made, press the [ENT] key. If the current setting is not to be changed, press [ENT] key once, or select "ESC" and press [ENT] to escape. Then, the second page of the menu, showing the status of stations N-Z, is printed out along with the status of stations A-M.

Make changes as necessary followed by pressing the [ENT] key, or select "ESC" and press [ENT] to escape. The Main Menu is reprinted.

NOTE: If any selection for stations A through M is found to be incorrect after the [ENT] key is pressed or "ESC" is selected, you have to start over from the Main Menu to make any corrections.

Menu-B: Set message

This menu allows you to specify which category of message you wish to receive. The category of messages is shown at the top of the next page.

LIST OF CATEGORIES

A	-----	Navigational warnings
B	-----	Meteorological warnings
C	-----	Ice reports
D	-----	Search and Rescue information
E	-----	Meteorological forecasts
F	-----	Pilot service messages
G	-----	DECCA messages
H	-----	LORAN messages
I	-----	OMEGA messages
J	-----	SATNAV messages
K	-----	Other electronic navaid messages (Messages concerning radio- navigation services)
L	-----	Navigational warnings-additional to letter A
M thru U	--	Not specified
V thru Y	--	Special services-allocation by IMO
Z	-----	No message on hand

NOTE: Categories A, B, and D cannot be rejected from printout, in accordance with international regulations.

Procedure

- 1) Get into the Main Menu, place the printing head above "B" and press either the [ENT] key or [ACCEPT] key. The following is printed out.

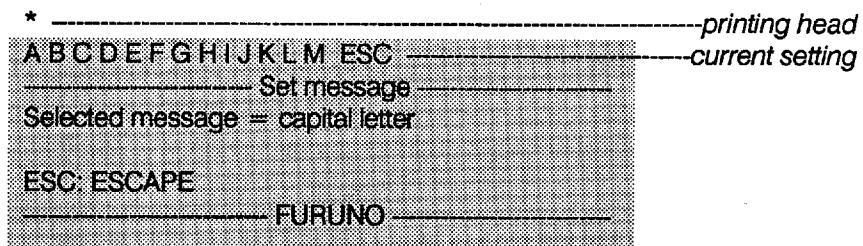

- 2) In accordance with the procedure for "station selection/rejection", select or reject each message category by pressing [ACCEPT] key to enter upper case character or [REJECT] key to enter lower case character. [<] and [>] keys may be used to skip over characters.

Message categories are identified by letters A, B, ..., Z, and they are divided into two groups just like station selection: A through M and N through Z.

- 3) As soon as selection/rejection for messages N through Z is completed, the Main Menu is printed.
- 4) To change an incorrect selection, move the cursor to that incorrect character and press either [ACCEPT] or [REJECT] key accordingly. The incorrect character is overprinted.

Menu-C: Set function

The items settable on this menu include automatic or manual (as registered) station selection, number of characters/line, navigation data to be printed out (connection kit: option), talker priority (if several navigation receivers are connected), printout interval, etc.

Procedure

1) Select "C" on the Main Menu, and the printout should look something like the one below.

Letter	Set function	Small	Capital
A	Monitor volume	Minimum	Maximum
B	Alarm volume	Minimum	Maximum
C	Character/Line	70	35
D	Beep	Off	On
E	NMEA (or CIF)	On	Off
F	System clock	On	Off
G	Station select	Auto *1	Manual
H	Comment	Off	On
ESC: ESCAPE			
----- FURUNO -----			

* -----printing head
-----current setting

*1 "AUTO" is available for Europe, USA, Japan, China, Hong Kong and Singapore area.

The meaning of each function is as follows;

- A ---- Signal monitor volume minimum/maximum
- B ---- Alarm volume minimum/maximum
- C ---- Number of character/line (Message print out only. For user setting 35 characters/line is always used.)
- D ---- Key press confirmation beep on/off
- E ---- Navigation data input on/off (See NOTE 1)
- NMEA ---- National Marine Electronics Association
- CIF ---- Furuno Communication InterFace
- F ---- Time from connected navigation equipment on/off
- G ---- Automatic or manual station selection
- H ---- Printing of character error rate on/off

2) Make necessary changes with the [ACCEPT] and [REJECT] keys. After making selections, press the [ENT] key.

NOTE: 1. When entry of "NMEA-0183" or "CIF" data is accepted, the NX-500 provides: time, heading, position, speed, bearing, wind direction and speed, water temperature, depth and ocean current direction and speed, as available, will be printed automatically at a preset time interval.

2. In order to activate the manual station selection, "G" should be entered in this C: Set function mode.
3. Error rate, message reception status (duplicate reception, etc.) may be added to each message received. You may activate the comment printout to check signal quality by entering "H." To delete it, enter "h."

Menu-D: Print received ID

1) Select "D" on the Main Menu. The NX-500 prints out station ID's and message categories, preceded by time information by hour, for messages received within the last 66 hours. An example print out is shown below.

```

Nav. print ready.
----- End of print ID -----
( Passed time . Received ID code )
00:AF00      00:BB01      01:LL01
02:CD01      02:ED00      04:DD01
----- Print ID -----

```

After printing out ID's, control is returned to the receiving mode.

Menu-E: Print status

Select "E" on Main Menu, and the NX-500 prints out the following:

```
Nav. print ready.
----- End of print setup data -----
Time          (UTC/SMT/LOCAL TIME)
Heading
Position      (Talker name)
Speed         (GRD/WATER) (Talker name)
Bearing       (Talker name)
Wind          Dir. (N/H) Vel. (True/Rel.)
Water temp
Depth
Current       Dir. Vel.
Print interval          2 Hours
Print start time       1 o'clock
----- Print NMEA setup data -----

----- End of print status -----
Selected station = capital letter
ABCdEfgHIJKLMnOPqRstUVWxyz

Selected message
ABCDEFGHIJKLMNopqrstuvwxyz

Selected status
Monitor volume      Maximum
Alarm volume        Minimum
Character/Line      70
Beep                Off
Data format         NMEA
System clock        On
Station select      Manual
Comment             Off
----- Print status -----
( Station, Message, Function )
```

] These items do not appear
when "System clock"
is off.

If "NMEA (or CIF)" is off in Menu-C, above "setup data" is not printed.

After printing out setup data, control is returned to the receiving mode.

Menu- F: Print NMEA (or CIF) data (Option)

The NX-500 can print out navigation data if interfaced with navigation equipment. To commence printout, select "F": Print NMEA (or CIF) data on Main Menu.

Nav. print ready		End of print NMEA data	
Date		SEPTEMBER 01 1992	
Time		09:56 53 UTC	
Heading		GYRO	157.5 DEG
Longitude		GPS	W101 52.60 MIN
Latitude		GPS	N 34 18.77 MIN
Speed	GRD	GPS	10.6 KT
Bearing	TRUE	GPS	155 DEG
Wind dir.		RELATIVE	L 145.5 DEG
Wind vel.		RELATIVE	11.0 KT
Water temp		CENTIGRADE	17.4 DEG
Depth	BELOW	SURFACE	205.6 M
Curr dir.	MAG		104.2 DEG
Curr vel			10.2 KT
		Manual print NMEA data	

Nav. print ready		End of print CIF data	
Date		SEPTEMBER 01 1992	
Time		09:56 53 UTC	
Heading		GYRO	157.5 DEG
Longitude		GPS	W101 52.60 MIN
Latitude		GPS	N 34 18.77 MIN
Speed	GRD	GPS	10.6 KT
Bearing	TRUE	GPS	155 DEG
Wind dir.		N UP	145.5 DEG
Wind vel.		RELATIVE	11.0 M/S
Water temp		CENTIGRADE	17.4 DEG
Depth			205.6 M
Curr dir.			104.2 DEG
Curr vel			10.2 KT
		Manual print CIF data	

NOTE: 1. The printout shows talker as follows.

<u>Talker device</u>	<u>Talken ID</u>	<u>Indication</u>
GPS	GP	GPS
Loran A	LA	LA
Loran C	LC	LC
Decca	DE	DC
Integrated Instruments	II	DR
Omega	OM	OMEGA

2. For periodical printout of navigation data, "Auto print ---" will be printed instead of "Manual print ---." Refer to page 2-14.

3. If navigation data is not available, the following is printed;

Nav. print ready	
----- End of print NMEA data -----	
----- Manual print NMEA data -----	

USER SETTING FOR PRINTOUT OF NAVIGATION DATA

When navigation data is fed to the NX-500 it may be used as a data logger, or a peripheral printer for navigation equipment.

- NOTE:*
1. To feed navigation data, a connector assembly (optional supply) is required.
 2. When no navigation equipment is connected, the following descriptions can be disregarded.

Selection of navigation data to be printed.

- 1) Select "C" on the Main Menu.
- 2) Set "NMEA (or CIF)" to ON by entering lower case character "e," then press [ENT] key. The NX-500 prints out the following ;

```
* ----- printing head
A B C D E F G H I ESC ----- current setting
----- Set NMEA item -----
Capital = Selected Small = Deselected
A: Time
B: Heading
C: Position
D: Speed
E: Bearing
F: Wind direction, velocity
G: Water temperature
H: Depth
I: Current direction, velocity

ESC: ESCAPE
----- FURUNO -----
```

Note: "CIF" may be printed instead of "NMEA" depending on internal setting.
Refer to APPENDIX B.

- 3) Enter upper or lower case characters to select or deselect navigation data, respectively. Press the [ENT] key to register selections.

Selection of talker for each navigation data

After the [ENT] key is pressed to register navigation data to be printed, the menu is printed as shown at the top of the next page.

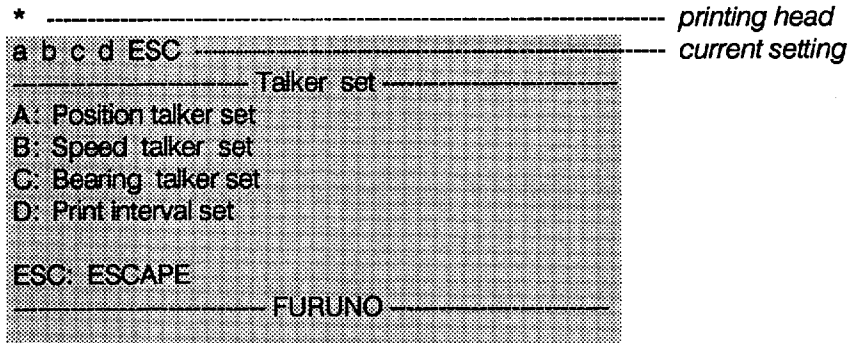

NOTE: In the default setting, A, B, C, and D are printed in lower case characters.

Assuming that this is the first time you are setting talker and print interval, you would press the [ACCEPT] key four times to change all characters on the top line to upper case characters, then press the [ENT] key.

Set position talker

After the [ENT] key is pressed, the position talker menu is printed out.

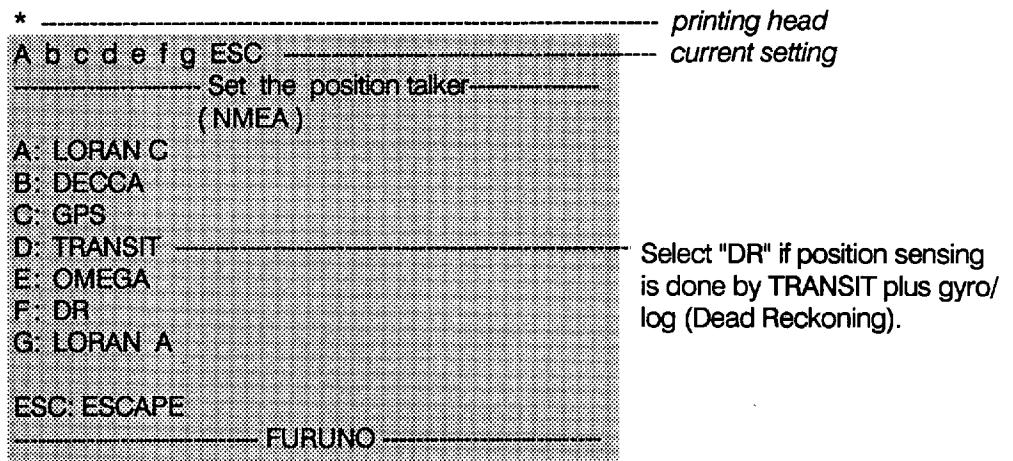

This menu is used to set talker the NX-500 is to "listen" to position data. The currently selected talker is shown in upper case character on the top line and the talker (navigation equipment) connectable to this unit are printed below.

To change the talker, you would press the [ACCEPT] key at characters representing a navigator. Supposing that, you want to switch the talker from LORAN C to GPS, you would place the printing head above c and press the [ACCEPT] key.

If you select wrong talker, select ESC and press the [ENT] key to return to the position talker sub menu. If you do not wish to change the talker, simply press the [ENT] key.

The speed talker menu is printed out.

Set speed talker

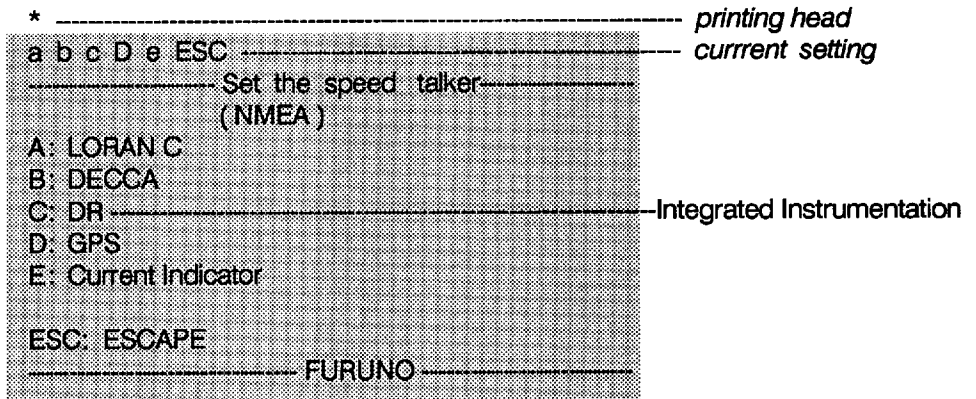

Similar to the manner in which positioning talker selection is done, set your desired talker equipment for ship's speed data, and then press the [ENT] key. The bearing talker menu is printed.

Set bearing talker

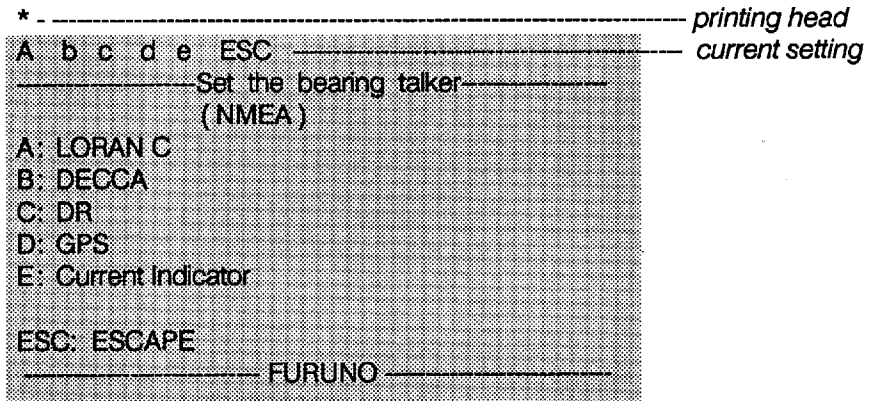

Set the talker for bearing data followed by the [ENT] key. Then the print interval menu is printed out.

Set print interval

This menu appears when "System clock" is on in the menu-C.

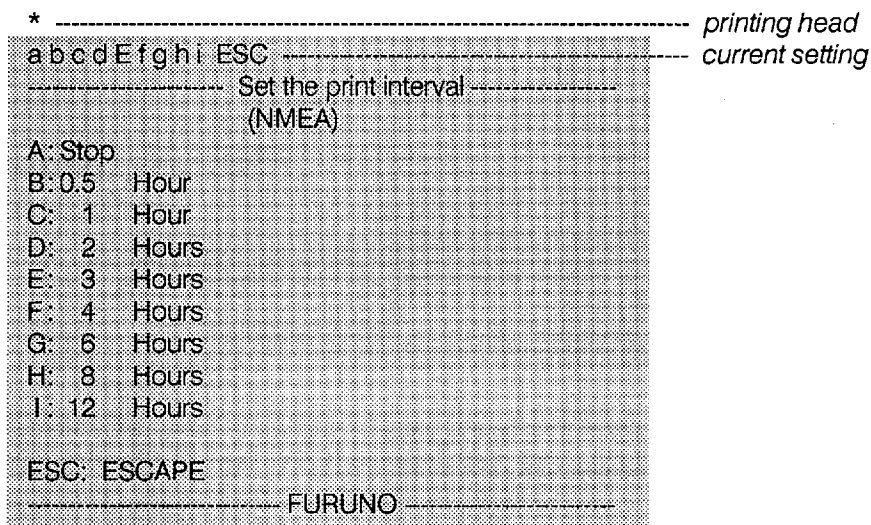

In the example, the current print interval setting is "E" (three hours), i.e., selected navigation data is printed every three hours. Select a print interval by placing the printing head above the character designating the interval desired followed by pressing the [ACCEPT] key. If you do not want automatic printout of navigation data, select A (stop).

After selecting a print interval, press [ENT]. Then, "print start time menu" is printed. (If A, B or C is selected, "print start time menu" is not printed.)

Set print start time

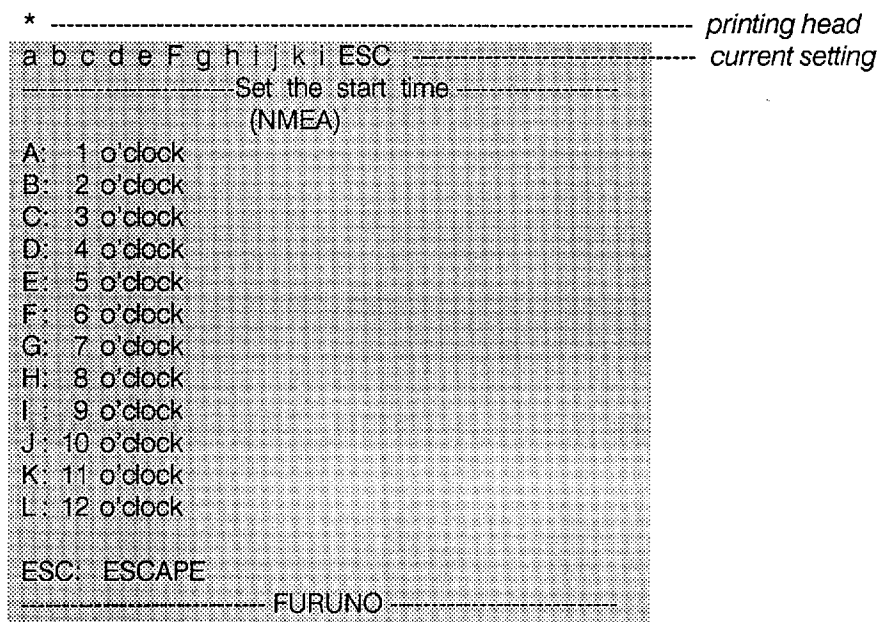

- 1) Move the cursor to the desired time and press [ACCEPT] key. The selected upper case character will be printed.
- 2) After making the selection, press the [ENT] key. Then, "Each talker set menu" is printed again.

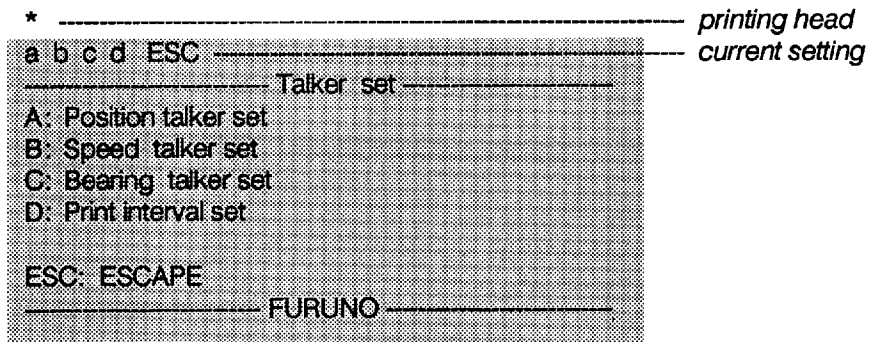

- 3) Press the [ENT] key to return to Main Menu.

NOTE: The NX-500 refers to clock data sent from navigation equipment to define print interval.

3. REPLACEMENT OF THERMAL PAPER

When the thermal paper runs out completely, the PAPER lamp lights and printing stops automatically.

When 1m of paper remains, a red paper end mark appears. Then replace the paper as follows.

REQUIRED THERMAL PAPER

Type: TP0340 (112mm×40m)
Code No.: 000-801-765
(one roll supplied.)

1. Press [FEED] key to draw out the remaining thermal paper.
2. Pull the paper container cover forward and take out the paper spool.
3. Curve the leading edge of the roll paper, to ensure smooth feeding, and set the paper spool to the new roll paper.

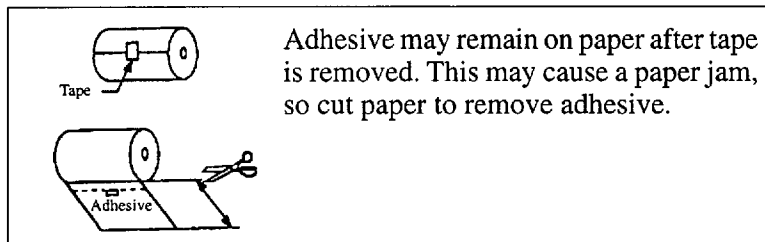
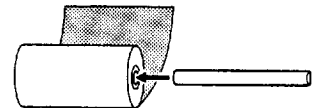
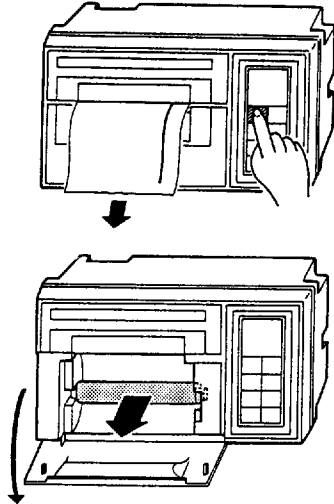

4. Insert the paper into the paper insertion slot just above the paper container and press [FEED] key to feed out the paper .

5. Set the paper in the paper container.

6. Press [FEED] key to confirm that the paper is properly aligned. If the paper comes out with the edges wrinkled, continue to press [FEED] key. Correct alignment will be made automatically.

7. Replace the paper container cover.

8. Press [ENT] key to complete the replacement of thermal paper.(PAPER lamp goes off .)
If the NX-500 receives messages with no paper, it prints out them after replacing the thermal paper.

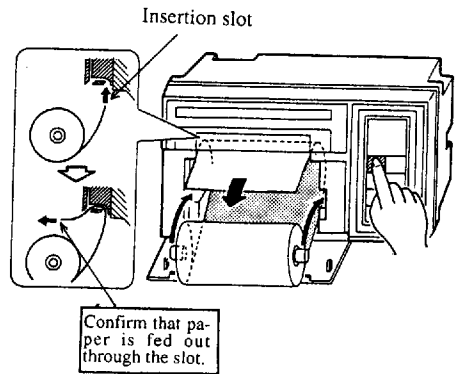

Remedy for paper jam

If the paper is jammed cut it off at the front panel and rewind it into the paper container.

4. MAINTENANCE

PERIODIC INSPECTION

This unit is aligned at the factory to deliver maximum performance. However, continued performance can not be expected without periodic inspection and maintenance. Important points to be checked regularly are tabulated below.

Check Item	Action
whip antenna	If cracked or broken, replace it.
junction of 2.6m whip antenna and preamp unit	If corroded, clean and waterproof with sealing compound.
coaxial cable	If sheath is cracked, seal with vinyl tape. If immersed with water, install new coaxial cable.
coaxial plug connection	If loosened, reconnect. If corroded, clean contacts.
power plug connection	If loosened, reconnect. If corroded, clean contacts.
battery connection	If corroded, clean power terminals.
grounding terminal	If corroded, clean terminal.

FUSE REPLACEMENT

To protect the equipment from serious damage, a fuse is provided on the rear cabinet of main unit. The fuse protects against overvoltage/reverse polarity of the ship's mains or internal fault of the equipment. If the fuse has blown, first find out the cause of the trouble before replacing it. A fuse rated for more than 3A should not be used, since it may permanently damage the equipment. Damage due to overfusing is not covered by the warranty.

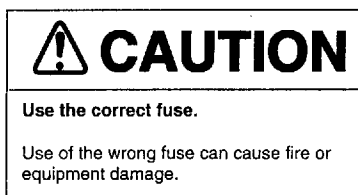

5. TROUBLESHOOTING

OPERATOR TROUBLESHOOTING

Equipment operating problems may be caused not only by a faulty circuit but also by poor signal condition, inadequate installation, or even operator error.

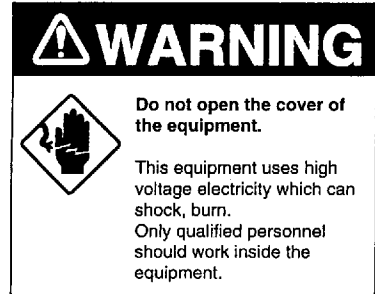

The list below shows the typical troubles which may be mistaken as equipment error.

SYMPTOM	POSSIBLE CAUSE	REMEDY
Power won't come on.	<ol style="list-style-type: none"> 1. Switch at main switch board is turned off. 2. Power connector is loose or disconnected. 3. Power fuse (3A) has blown. 4. Battery is dead. 	<ol style="list-style-type: none"> 1. Turn on the main switch. 2. Plug connector firmly. 3. Check mains voltage and polarity first, then replace fuse. If it blows after replacement, call for service. When driven from AC mains, check rectifier as well. 4. Charge or replace battery.
Paper won't advance.	<ol style="list-style-type: none"> 1. Paper is jammed. 2. Paper roll has slipped out of supporting catches. 	<ol style="list-style-type: none"> 1. Clean paper feed path. 2. Load paper correctly.
Paper feeds but no recording.	<ol style="list-style-type: none"> 1. Paper is loaded incorrectly (front-side-back). 2. Ordinary paper (non-thermal) is used. 3. Navtex signal is not received. 4. Navigation data is not fed to printer section. 	<ol style="list-style-type: none"> 1. Load paper correctly. 2. Use specified thermal paper. 3. Check if LOCK lamp (reception indicator) lights occasionally (at least once every 4 hours). While LOCK lamp lights, monitor Navtex signal. 4. Check if EXT "connector jack" (option) is loose. (NX-500 does not print Navtex message without "link wire" in the [EXT] connector plug.)
LOCK lamp does not light. (Navtex signal can not be heard from monitor speaker.)	<ol style="list-style-type: none"> 1. No Navtex signal at this time. 2. Antenna connector is loose or disconnected. 3. Preset switch (S2) in the "Set window" is incorrectly set. 4. Internal fault. 	<ol style="list-style-type: none"> 1. Attempt to receive signal, considering the transmission schedule. 2. Check antenna connection. 3. Select "PRE (50 Ω)" only when the NX-500 Preamp Unit is used. * When "PRE" is selected, +12V is applied to coaxial cable. 4. Conduct system-diagnosis. (The RF stage should also be checked.)

--- continued ---

SYMPTOM	POSSIBLE CAUSE	REMEDY
Inaudible or insufficient monitor/alarm volume.	1. Inadequate setting in Menu-C.	1. Check setting in Menu-C: Set function.
Unnecessary stations can not be rejected.	1. "Manual" is not selected in Main Menu-C: Set function.	1. Confirm selected parameters by selecting Menu-E: Print status.
"Automatic station select" can not be done.	1. Navigation data is not fed.	1. Check whether any navigation equipment is connected to EXT connector on the rear cabinet.
Same messages are repeatedly printed.	1. The NX-500 is turned on/off frequently.	1. It is requested that the NX-500 is kept on during an entire voyage.
Printing of message is suspended.	1. Character error rate exceeds 33%.	1. Check antenna connection. * Signal strength decreases markedly if the distance to the Navtex station exceeds 200 nm.
Paper turned black.	1. Paper has been stored in hot environment or exposed to active chemical gas.	1. Store paper in dry and cool place.

SYSTEM DIAGNOSIS

The NX-500 is provided with a system diagnosis program, which checks the unit for proper performance.

- 1) To run the system diagnosis program, turn the power switch on while pressing and holding the [ACCEPT] key while tuning the power on.
After heard a beep, release the [ACCEPT] key.

```

Push the keys in following sequence
DIMMER ENTER > ACCEPT
FEED MENU < REJECT
-----KEY TEST-----
fghijklmnopqrstuvwxyz[ ]~+
CDEFGHIJKLMNOPQRSTUVWXYZ[ Y] ^ _ 'abcde
!#$%&'()*+,-./0123456789;<=>?@AB
Test print
EEPROM test ----- OK
RAM test ----- OK
ROM test ----- OK
-----PRINTER CPU SELF TEST-----

FURUNO ELECTRIC CO., LTD.
NAVTEX RECEIVER NX-500
MAIN CPU Ver. 3.00-----
NAV CPU Ver. 3.06-----

```

version no. may
be different

2)The results of the ROM/RAM test are indication. If any malfunction of ROM/RAM is detected, "NG(No good)" will be printed instead of "OK". Should this occur, switch off the NX-500 and ask your dealer for servicing. After all characters and symbols used by the NX-500 are printed, you are requested to press each key once in the sequence of;

[DIM] [ENT] [>] [ACCEPT] [FEED] [MENU] [<] [REJECT]

3)If the key is functioning properly, a beep is generated.

If you press a key out of the prescribed sequence, recontinue with the correct key.

4)After the key test is completed, the NX-500 advances to the second step of the diagnosis program and prints out;

```
Send data
ZCZC TE01
ABC12345
NNNN
NAVTEX signal send and receive test
External RAM test ----- OK
RAM test ----- OK
ROM test ----- OK
----- NAVTEX CPU SELF TEST -----
Key test ----- OK ----- key test result
```

5)When the last line "Send data" is printed, the NX-500 signal simulator is activated. Simulated signal (ZCZC TE01, ABC12345, NNNN) is output from the speaker. After 5 seconds, the following will be printed.

```
Turn off the power SW
Self test is completed

Received data
ZCZC TE01
ABC12345
NNNN
```

6)Confirm that the received data (ZCZC TE01, ABC12345, NNNN) is identical to the simulated signal.

7)At this stage all keys except [DIM] key and [FEED] key are inoperative. To return to the receiving mode, you have to switch the power off and on again.

6. INSTALLATION

GENERAL MOUNTING CONSIDERATIONS

This equipment can perform its intended functions only if it is installed properly. Keep in mind the following when selecting a mounting location.

WATER SPRAY

The NX-500 is designed and constructed to be able to withstand the humidity and corrosive atmosphere common in small boats, but it is not designed to be used outside, directly exposed to the environment! Salt water spray will most assuredly cause damage to the sensitive components inside.

FURUNO will assume no responsibility for the damage caused by exposure to water spray.

MECHANICAL SHOCK AND VIBRATION

The NX-500 itself is constructed to withstand minor shocks and engine vibrations, but excessive and continued shock can shorten the life of the precision printer mechanism. Shock may also degrade the print quality due to uneven contact between the printer head and the thermal paper.

HEAT ACCUMULATION

The NX-500 consumes very little power, so there is no need for forced air ventilation. However, it is recommended to provide at least some space around the unit to allow circulation of cooling air.

The unit should be kept out of direct sunlight or at least shaded because of heat that can build up inside the cabinet. Excessive heat can darken the thermal paper.

ONBOARD NOISE

The NX-500 contains a very sensitive receiver. To avoid mutual interference with other radio equipment, do not install this unit near an SSB/VHF/CB radiotelephone.

MAIN UNIT INSTALLATION

The main unit can be mounted on either a tabletop, bulkhead or in a panel. Make sure the selected location is strong enough to support the main unit against possible vibration and shock. If necessary, appropriate reinforcement measures should be made on the mounting area.

TABLETOP/BULKHEAD MOUNT

1. Drill four fixing holes for the hanger.
2. Fix the hanger with the tapping screws ($\phi 5 \times 20$) supplied.
3. Place the unit in the hanger and tighten knobs.

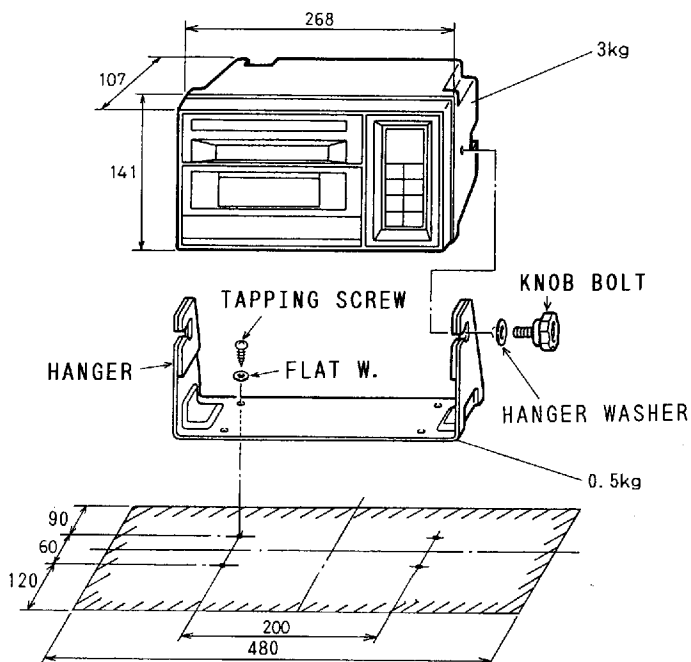

NOTE: When the unit is installed on a bulkhead, fix the hanger as shown right.

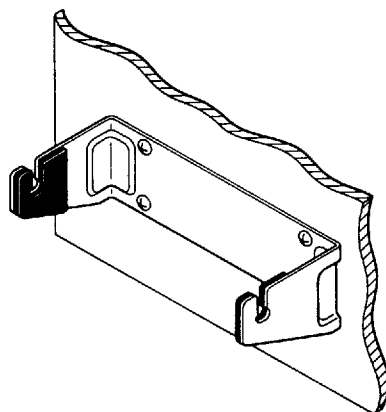

FLUSH MOUNT

NOTE: Flush mount panel kit is optionally supplied.

1. Prepare a cutout in the mounting area and drill four fixing holes for the flush mount angles.
2. Fix the flush mount angles to the main unit, and connect the cables.
3. Fix the main unit to the panel cutout.
4. Fix the flush mount panel to the flush mount angles with the screws and washers supplied.

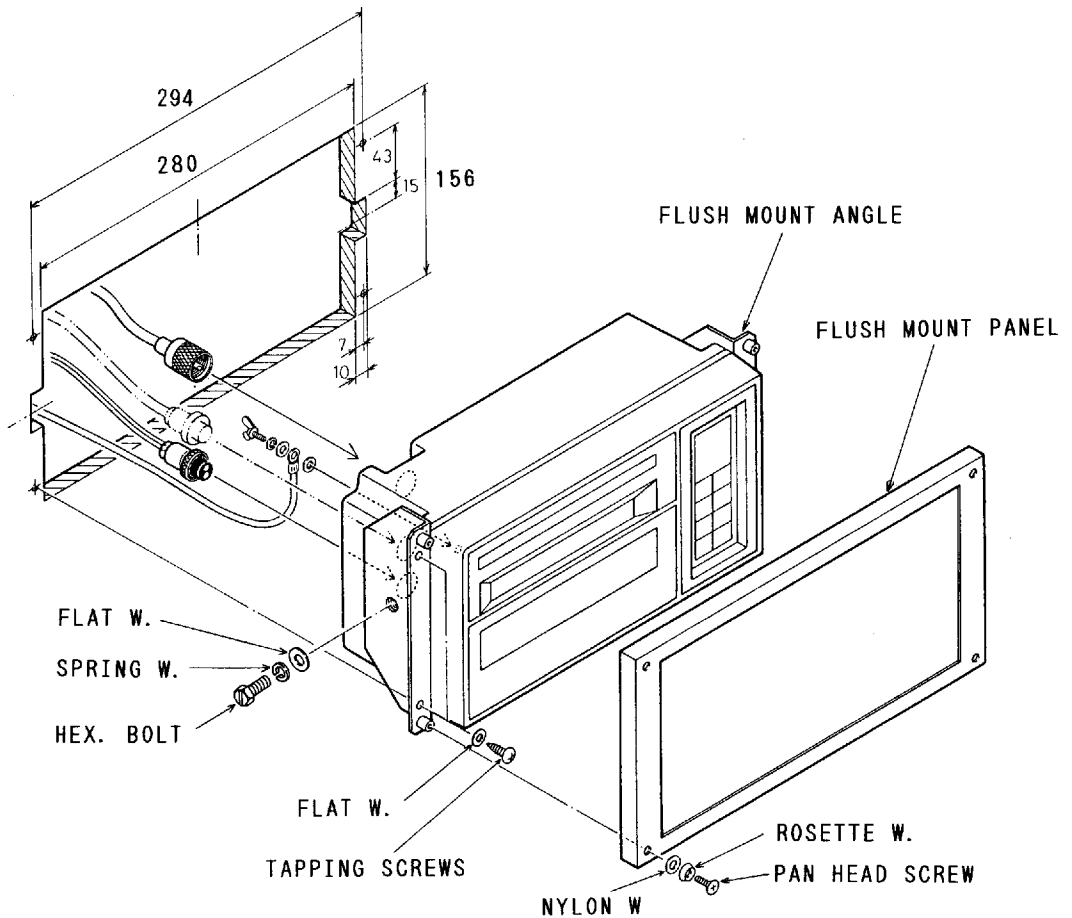

ANTENNA INSTALLATION

Performance of the NX-500, especially in weak signal areas, is directly related to the antenna installation. In general, the antenna should be installed as high as possible on the boat, free from the influence of nearby antennas, rigging and masts.

The antenna commonly used for the navtex receiver is a long wire or 6 to 7m whip with slanted wire of approx. 10 meter long. In order to receive signals in every situation, the total antenna length should be at least 15 meters.

To allow antenna installation on smaller boats where the long wire antenna can not be stretched, the NX-500 is designed to be connected to an active antenna (Preamp Unit with 1.2m whip antenna).

If the NX-500 is installed on a boat equipped with a 410 to 535kHz MF transmitter or an HF transceiver (frequency higher than 1.6MHz, 200W of power or more), it is requested to install the optional Preamp Unit to protect the unit from damage by induction. The Preamp Unit is designed to withstand a 30Vrms antenna input for at least 15 minutes.

PASSIVE ANTENNA

If your boat is large enough, install a long wire and/or whip with slanted wire antenna. When a long wire antenna is used, it should be dedicated to this receiver only. The antenna should never be shared with a receiver/transmitter by means of an antenna switch box, to ensure that signals can be received always.

In the case of a sailboat, the backstay itself can be used as the antenna provided both ends are properly insulated and it is not shared with an HF transceiver.

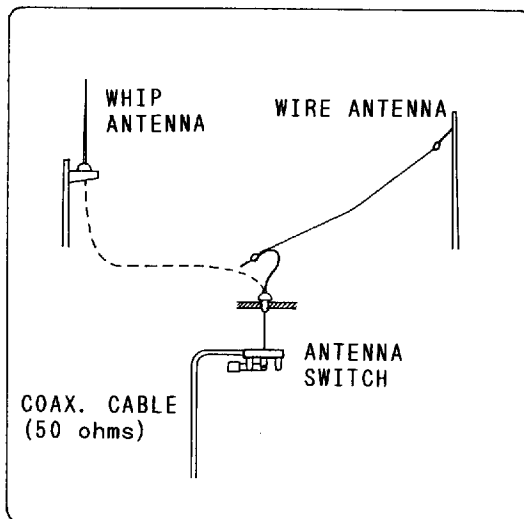

Indoor Wiring

To minimize interference from onboard electronic equipment, a 50 ohm coaxial cable (RG-8/U, RG-5/U, etc.) should be used for indoor wiring. (Connect the center conductor of the coaxial cable to the antenna wire and insulate the outer conductor with vinyl tape.)

ACTIVE ANTENNA (Preamp Unit; option)

If your boat is small and you can not provide space for such a long antenna, it is recommended to install the optional Preamp Unit and 1.2m Whip Antenna.

The body of the Preamp Unit can be mounted in two ways;

1. The bottom of the Preamp Unit is designed to accept a threaded extension mast of 1 inch diameter. The pitch of the thread should be 14 threads per inch. To prevent undue flexing of the mast in heavy winds, the mast should not be longer than 2 meter (7 feet).
2. The side of the Preamp Unit has a molded channel so that it may be mounted directly to a stub mast with two stainless steel hose clamps. Hose clamps must be arranged locally.

Screw the 1.2m Whip Antenna tightly onto the Preamp Unit and waterproof the junction and other exposed metallic parts with sealing compound (silicone rubber, putty, etc.).

Instead of using the 1.2m Whip Antenna, an antenna wire of 3 to 6 meter long may be connected as shown right.

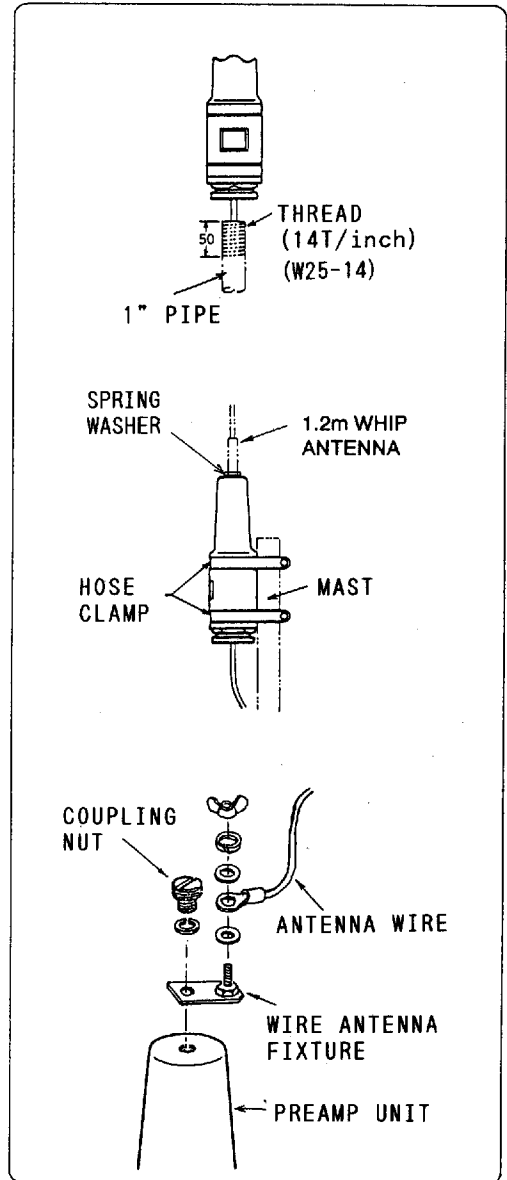

NOTE 1: If the Preamp Unit is installed, the preset switch (S2) inside the main unit must be set to the "ACT(50 Ω)" side to supply 9Vdc to the Preamp Unit. Refer to page 6-8.

2. If receiver sensitivity is insufficient on preamp unit-equipped sets produced in February 1990 and after, ground the preamp unit referring to page APC-1.

CABLE CONNECTIONS

Three cables must be connected to the main unit: power, antenna and ground.

The power and antenna cables are to be connected to their respective connectors at the rear of the main unit, and the ground wire directly to the rear panel terminal. General connecting instruction is illustrated on the next page.

POWER CABLE

The NX-500 is designed to operate normally at any voltage between 10.8 and 40Vdc, and thus it can be connected directly to a 12V, 24V or 32V power system without any presetting inside the unit

For power connection, a 3m cable is provided. Connect its end leads to a distribution box, breaker panel, battery or rectifier; the red lead to positive (+) terminal and the black lead to negative (-) terminal.

CAUTION: To protect the equipment from transient voltage change and accidental reversal of the polarity of the power supply a fuse is provided in the main unit. Should the fuse blow, first suspect wrong polarity or short circuit. Locate and remove the cause on replacement of the fuse.

If it is necessary to extend the power line, use an appropriate size cable, taking into account the supply voltage and extension length (thicker wire for lower supply voltage and longer extension distance). A 2mm square cable (US gauge 14, British gauge 16) will be sufficient for a 10m extension in the 12V system. Do not make the connection by twist wrapping but by soldering.

ANTENNA CABLE

If the Preamp Unit with 0.6m coaxial cable is installed, an extension coaxial cable (10/20/30/40/50m) is supplied for connection between the preamp unit and the main unit. Tape the joint of the cables with a self-vulcanizing tape and a vinyl tape. Refer to the figure on page 6-7.

If a wire and/or whip antenna is installed, run a 50 ohm coaxial cable between the antenna base (lead-in)/antenna switch and the main unit, and fabricate the cable end as shown below. Depending on the cable size, use an appropriate reducer, provided as standard supply. **If you do not know how to solder, leave this job a qualified technician, since most radio troubles are caused by improper antenna connections.**

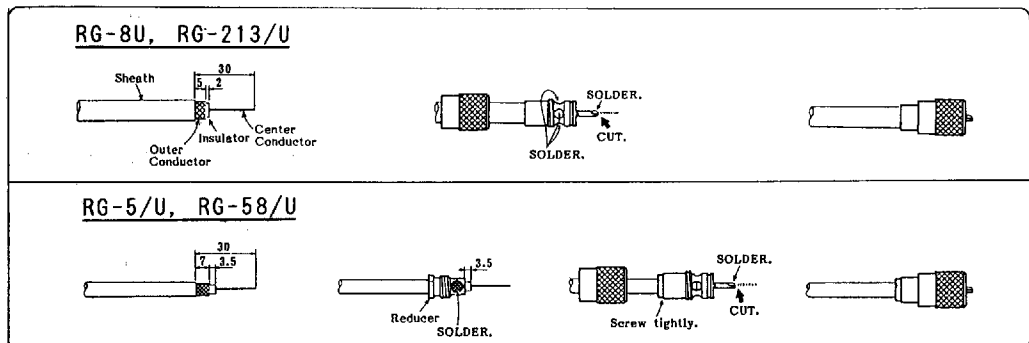

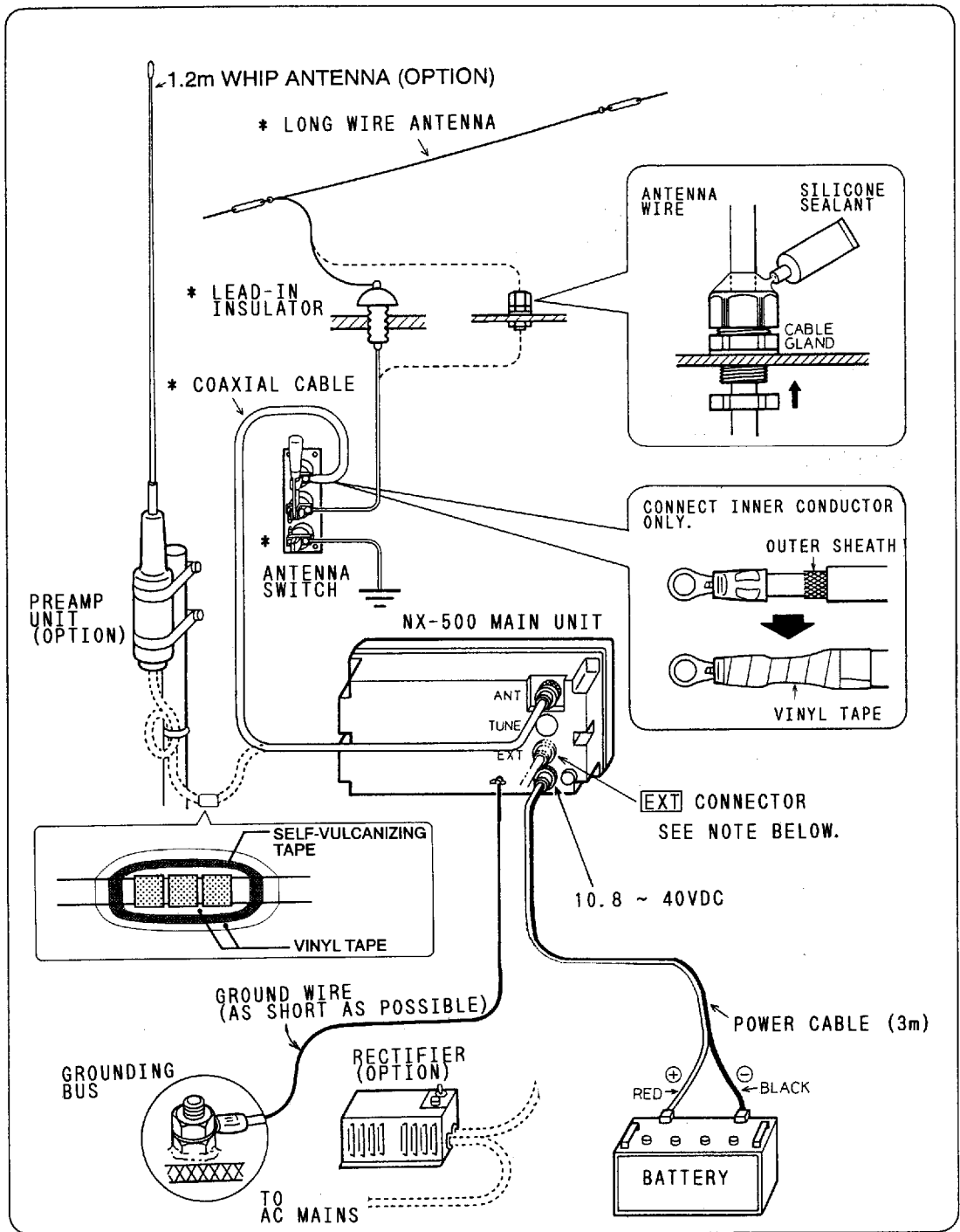

NOTE : 1. asterisks (*) indicate local preparation.

2. For connection of navigation equipment to the [EXT] connector(option), refer to page 6-9.

GROUNDING WIRE

In order to minimize interference from onboard equipment, it is important to ground the unit to the boat's grounding bus.

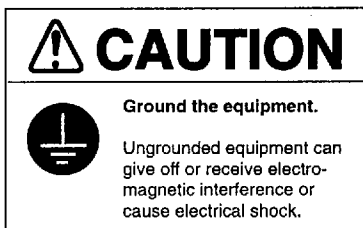

Fasten the ground wire to the ground terminal at the rear panel of the main unit, and connect the other end to the nearest efficient ground spot on the boat.

INITIAL SETTING (Antenna Selection)

Slide switch S2, inside the main unit, should be set according to the type of antenna used. Take the rubber cap "TUNE" off at the rear of the main unit and locate slide switch S2.

1. When Preamp Unit is not used;

Set S2 to "WIRE (High Impedance)." If interference is a problem, adjust the matching coil while monitoring the receiving signal. See NOTE 2.

2. When Preamp Unit is used;

Set S2 to "ACT (50Ω)."

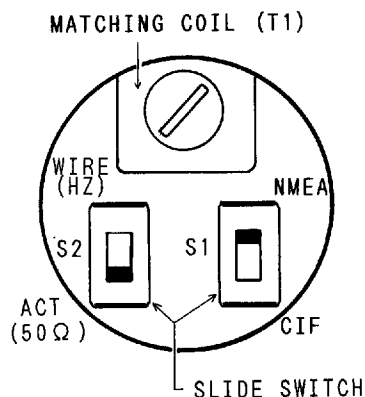

Factory setting is "WIRE."

NOTE 1. For the function of S1, refer to page 6-10.

2. When S2 is set for "WIRE," matching coil T1 is inserted to enable tuning of the telex signal. To tune the telex signal, press [ACCEPT] key (in the receiving mode) to monitor raw NAVTEX signal and slowly rotate the core of T1 until telex signal is heard clearly. It should be noted that the core can be rotated only 2.5 turns between fully counterclockwise and fully clockwise positions. Rotation beyond this limit may damage the ferrite core.

CAUTION

When "ACT" is selected, never make a short circuit between the center and outer conductors of the antenna connector. 12Vdc for the Preamp Unit is overlaid on the connector.

EXTERNAL CONNECTIONS

EXTERNAL INPUT/OUTPUT

At the rear of the unit a mounting hole for a 10P connector receptacle is provided. By fitting the optional "connector assembly" to this receptacle, the following data/signal can be fed or taken out from the NX-500.

Pin No.	DATA/SIGNAL	ITEM	EQUIPMENT TO BE CONNECTED
1 2	Navigation data in NMEA-0183 or Furuno CIF format	1) L/L data input for automatic station selection. 2) data logger	LORAN/GPS/NNSS, Temperature Indicator, Current Indicator, Wind Indicator, Echo Sounder, Interface Unit. (Furuno IF-5000 etc.)
3-5	Not used		
6 7	SAR Alarm (contact closure signal)	Alert for SAR message.	Buzzer/Bell, Alarm lamp, etc.
8	AF Out	Navtex signal output. (1700± 85Hz, 0dBm)	Accurate audio tape recoder (MT-12), Headphone, etc.
9	AF Input	Navtex signal input.	Tape recorder, All wave receiver, etc.
10	GND	Shielding of AF out/input signal cables.	---

SAR ALARM

Pins No. 6 and 7 have contact closure type output, and thus can be used to alert that a SAR (Search And Rescue) message is being received. If it is necessary to signal the situation in a louder sound level than the built-in speaker or by some other means, such as a flashing light, use this contact signal. The relay contact is capable of handling a 1A/20W load.

To maintain good receiving condition, the device connected to the alarm terminal should not generate radio noise. (A poor quality electric buzzer may cause heavy radio noise due to arcing at its contact.)

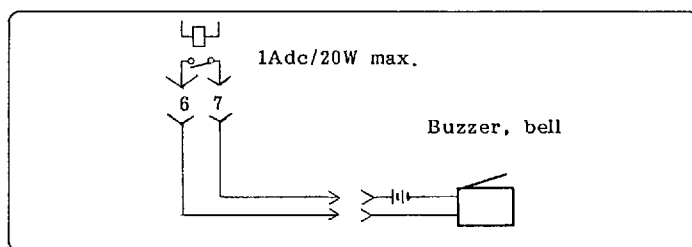

AF OUT/INPUT

The receiver and the printer sections are electrically independent of each other. That is, the audio signal (frequency shift tone = $1700 \pm 85\text{Hz}$) from the internal receiver is fed to the printer section through the jumper link J23 on the NAV RCV board. If a NAVTEX signal is available from an external all-wave receiver, its audio output may be connected to the printer input of this unit. The AF output signal may also be used for tape recording and playback of Navtex messages, by accurate audio tape recorder, for the demonstration purposes, etc.

NAVIGATION DATA

When navigation data in Furuno CIF (Communication InterFace) or NMEA-0183 (National Marine Electronics Association) format is fed to the NX-500, the NX-500 can function as a peripheral printer for navigation equipment. Automatic station selection is also done if L/L data are fed.

Connection between navigation equipment and NX-500 should be done using a twisted-pair cable (0.2 sq. or bigger) having a shield. The shield of the cable should be grounded to the chassis of the navigation equipment.

To connect more than one navigation device, use of Furuno Interface Unit IF-5000 may be required. However, note that only one type of data format (either CIF or NMEA) can be fed to the NX-500.

The FURUNO equipment which can transmit data in NMEA (or CIF) format are listed on page 6-12.

For the connection between navigational equipment and the NX-500, refer to page 6-13 .

Setting for Furuno CIF data

When navigation data in Furuno CIF format is applied, the DIP switch S1 in the set window on the rear of the unit should be set to "CIF."

After setting, **turn off the power and then turn on the power again** to read the DIP switch setting.

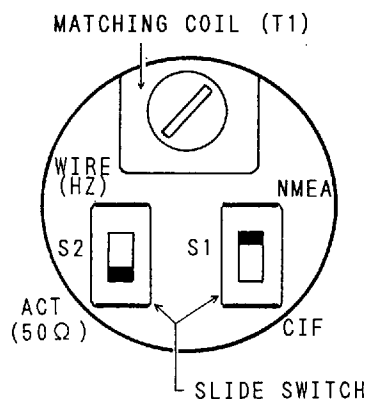

Fixing optional "Connector Assembly" and connection to "[EXT] Connector Plug"

CAUTION

1. The following modification should be done with the power and coaxial cables disconnected.
2. Don't remove "jumper plug" on the NAV RCV board when no external equipment is connected, otherwise normal printing will not be available.

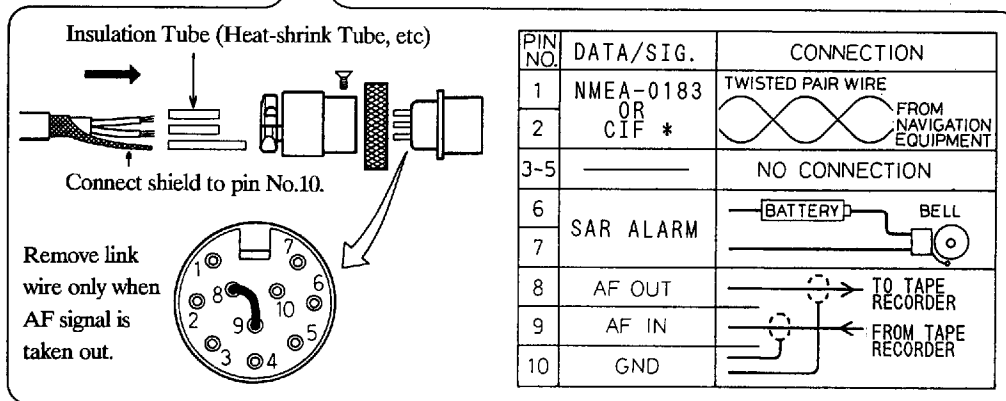
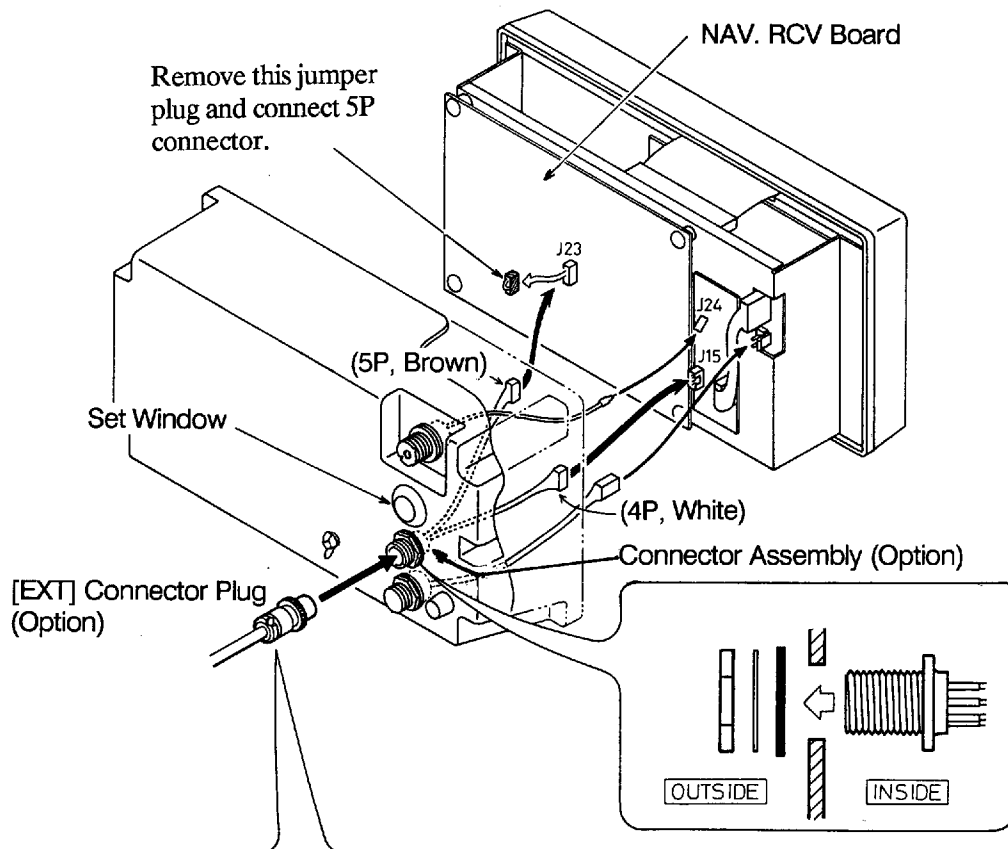

*: Select "NMEA" or "CIF" with the switch located in the "Set Window."

LIST OF FURUNO EQUIPMENT TO BE CONNECTED

MODEL	DATA												
	NMEA-0183	Format CIF	Time	Heading	Position	Speed	Bearing	Wind direction, velocity	Water temperature	Depth	Current direction, velocity	Remarks	
NAVIGATION EQUIP.													
LC-90MkII	o	o	o		o	o	o						
GP-500Mk2	o	o	o	o	o	o	o						
GP-70Mk2	o	o	o	o	o	o	o						
GP-50	o	o	o	o	o	o	o						
FSN-70	-	o	o	o	o		o						
TEMP. INDICATOR													
TI-20	o	o							o				
CURRENT INDICATOR													
CI-30	-	o		o		o	o				o		
WIND INDICATOR													
FW-200	-	o						o					
ECHO SOUNDER													
FCV-10	o	o								o			
FCV-140	o	o								o			
FCV-271	o	o								o			
FCV-360 series	o	o								o			
FCV-381/382	o	o								o			
FCV-522/552	o	o								o			
FCV-581/582	o	o								o			
FCV-663/665	o	o								o			
FCV-781/782	o	o								o			
FMV-601/602	o	o								o			
FMV-603	o	o								o			
INTERFACE UNIT													
IF-5000		o											

7.SPECIFICATIONS

RECEIVER SECTION

- | | |
|---------------------------|---|
| 1. Receiving Frequency: | 518kHz |
| 2. Receiving System: | Straight amplifier |
| 3. Calling Sensitivity: | 2 μ V emf (50 ohms, at 4% error) |
| 4. Input Protection: | Withstands 30V rms, 15 min. or more (w/preamp unit) |
| 5. Spurious Emission: | 1nW or less |
| 6. Output Level: | 1700 \pm 85Hz, 0dBm/ 600ohms |
| 7. Set ID Storage Period: | More than 1 year after power off. (No back-up battery required due to EEPROM) |
| 8. Memory Capacity: | 64 ID codes, Approx. 4000 characters, storage hour—66 hours |
| 9. Alarm: | Built-in audible and visual alarm |

PRINTER SECTION

- | | |
|----------------------------|--|
| 1. Printing System: | Serial thermal head printing system |
| 2. Printing Paper: | Thermal paper TP-0340 (112mm \times 40m) |
| 3. Character Construction: | 9 \times 7 dot |
| 4. Dot Pitch: | 0.28mm |
| 5. Number of Characters: | Max. 35 or 70 characters/line, programmable (35 characters/line for parameter setting) |
| 6. Print Speed: | 31 characters/sec. |

GENERAL

- | | |
|----------------------------------|--|
| 1. Power Supply: | 10.8 to 40VDC |
| 2. Power Consumption: | 15W or less for printing, 9W for stand-by (at 24V) |
| 3. External Input/Output Signal: | |
| AF Signal (Input/Output): | 0dBm/600ohms, 1700 \pm 85Hz |
| Alarm Signal (Output): | Contact closure signal (max.1A, 12W) |
| Navigation Data (Input): | Furuno CIF or NMEA-0183 format |
| 4. Environmental Conditions: | -15 $^{\circ}$ C to +55 $^{\circ}$ C, Relative humidity 0 to 95% |
| 5. Dimensions and Weight: | Main Unit 268(W) \times 141(H) \times 107(D)mm (10.6 \times 5.6 \times 4.2 in) 3kg (6.6 lbs)
w/Hanger 322(W) \times 167(H) \times 107(D)mm, 3.5kg |



PREAMP UNIT(NX-5, Option)

- | | |
|------------------------------|--|
| 1. Frequency Range: | 518± 6kHz |
| 2. Gain: | 0dB (50ohms) |
| 3. Power Supply: | 9 to 12VDC, supplied from NX-500 via coaxial cable |
| 4. Environmental Conditions: | - 25°C to 70° C , Relative humidity 95% |
| 5. Dimensions and Weight: | 66(Dia.)×220(H)mm, 0.6kg |
| 6. Coating Color: | White |

Complete Set

No.	Name	Type	Code No.	Q'ty	Remarks
1	Main Unit	NX-500	000-040-142	1 set	Refer to lists below.
2	Accessories	FP08-00500	000-040-145	1 set	
3	Installation Materials	SP08-00900	000-040-144	1 set	
4	Spare Parts	SP08-01000	000-040-143	1 set	
5	Option				

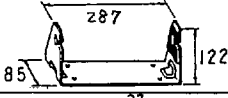
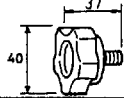
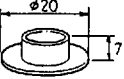
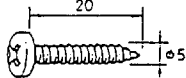
Accessories

Name	Outline	Type	Code No.	Q'ty
Hanger Assembly		FP08-00510	004-511-550	1
Knob Bolt		XG-B2 M8×20 SUS	000-800-418	2
Hanger Washer		05-029-0132-1	100-087-911	2
Tapping Screw		5×20 SUS304	000-800-488	1
Flat Washer		M5 SUS304	000-864-128	1

Installation Materials

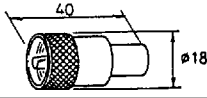
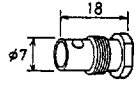
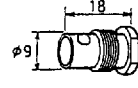
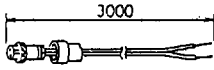
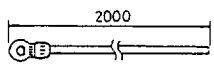
Name	Outline	Type	Code No.	Q'ty
Coaxial Plug		FM-MP-7	000-108-859	1
Reducer		MP-M3A	000-108-860	1
Reducer		MP-M5A	000-108-861	1
Cable Assembly		08S0157-0	000-116-030	1
Ground Wire		08S0087-0	000-108-138	1

Spare Parts

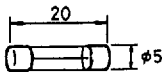
Name	Outline	Type	Code No.	Q'ty
Fuse		FGMB 3A 125V	000-104-909	2

Option

No.	Name	Type	Code No.	Q'ty	Remarks
1	Preamp Unit	NX-5-N-0	000-040-248	1 set	no extention cable
		NX-5-N-10	000-040-241		w/10m cable, wire ant. fixture
		NX-5-N-20	000-040-242		w/20m cable, wire ant. fixture
		NX-5-N-30	000-040-243		w/30m cable, wire ant. fixture
		NX-5-N-40	000-040-244		w/40m cable, wire ant. fixture
		NX-5-N-50	000-040-245		w/50m cable, wire ant. fixture
2	Whip Antenna	08S0256	000-130-046	1	1.2m whip
3	Rectifier	PR-62 100VAC	000-013-484	1	For AC ship's mains
		PR-62 110VAC	000-013-485		
		PR-62 120VAC	000-013-486		
		PR-62 230VAC	000-013-487		
4	Coaxial Cable Assembly	OP04-2 10m	000-286-010	1	For extending coaxial cable
		OP04-2 20m	000-286-020		
		OP04-2 30m	000-286-030		
		OP04-2 40m	000-286-040		
		OP04-2 50m	000-286-050		
5	External Connector Kit	OP08-6	004-511-790	1 set	[EXT] connetor and wire assy. for internal connection
6	Flush Mount Kit	OP08-4	004-511-330	1 set	

Contents of Flush Mount Kit (option)

No.	Name	Type	Code No.	Q'ty	Remarks
1	Flush Mount Panel Assy.	OP08-4	004-511-630	1	
2	Hex. Bolt	M8×16 SUS304	000-862-145	2	For fixing main unit
3	Spring Washer	M8 SUS304	000-864-262	2	
4	Flat Washer	M8 SUS304	000-864-130	2	
5	Tapping Screw	5×20 SUS304	000-800-488	4	For fixing flush mount angles
6	Flat Washer	M5 SUS304	000-864-128	4	
7	Panhead Screw	M3×8	000-861-495	4	For fixing flush mount panel
8	Rosette Screw	M3 C2700W	000-864-900	4	
9	Nylon Washer	2.8×7×0.5	000-800-728	4	

- Note: One roll of recording paper (thermal paper, type TP0340, 112mm×40m, Code No. 000-801-765, is supplied with the roll fixed in the paper container of the main unit.)

At-sea Electronic Maintenance Parts (option)

No.	Name	Type	Code No.	Quantity	
				per set	spare
1	Power Board	08P3154	004-511-530	1	1
2	Relay	G2VN-234P-DC12V	000-108-984	2	1
3	Lamp	AXT 4.2/30 5V 115MA	000-111-662	1	1
4	Fuse	FGMB 3A 125V	000-104-909	1	1



表 1 TABLE 1

箱 体 DIMENSIONS	公 差 TOL.
L ≤ 50	± 1 mm
50 < L ≤ 100	± 2 mm
100 < L ≤ 500	± 3 mm
500 < L ≤ 1000	± 4 mm

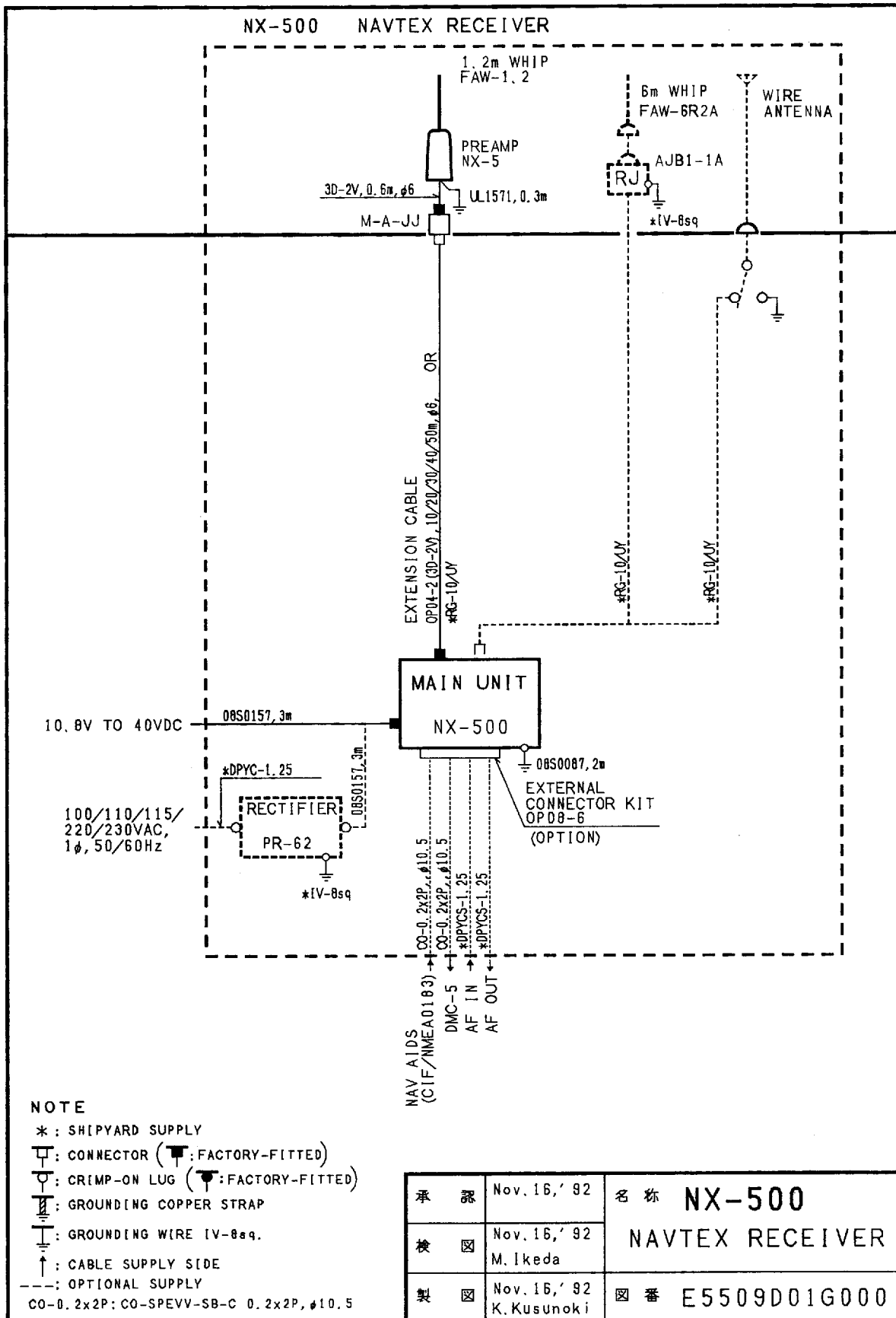
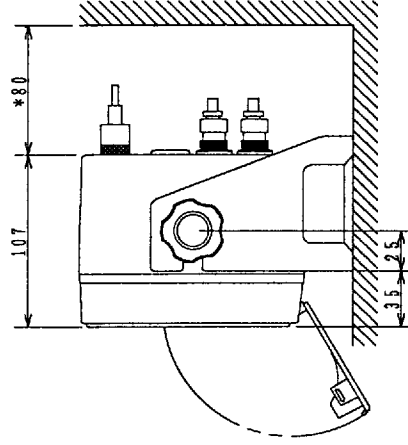
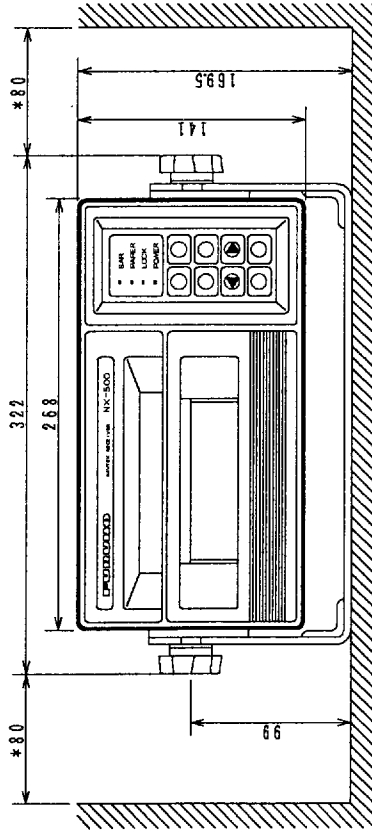
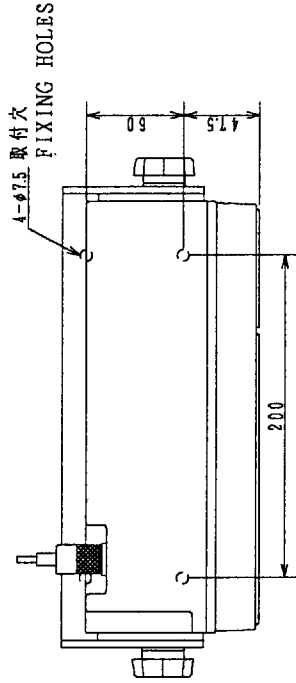

注 記
 1) 指定外の寸法公差は表1による。
 2) * : 推奨する最小サービス空間寸法。

NOTE

1. TABLE 1 INDICATES TOLERANCE OF DIMENSIONS.
2. * : RECOMMENDED SERVICE CLEARANCE.

DRAWN	Oct. 16 '72 T. YAMAZAKI
CHECKED	Oct. 16 '72 K. KAWAKUCHI
APPROVED	Oct. 20 '72 at Sanguchi
SCALE	1 / 4 MASS 2.7 kg
WORKING	C5509-G01-B

TITLE	NX-500
名 称	ナビテックス受信機
外 寸 図	
NAME	NAVTEX RECEIVER
OUTLINE DRAWING	

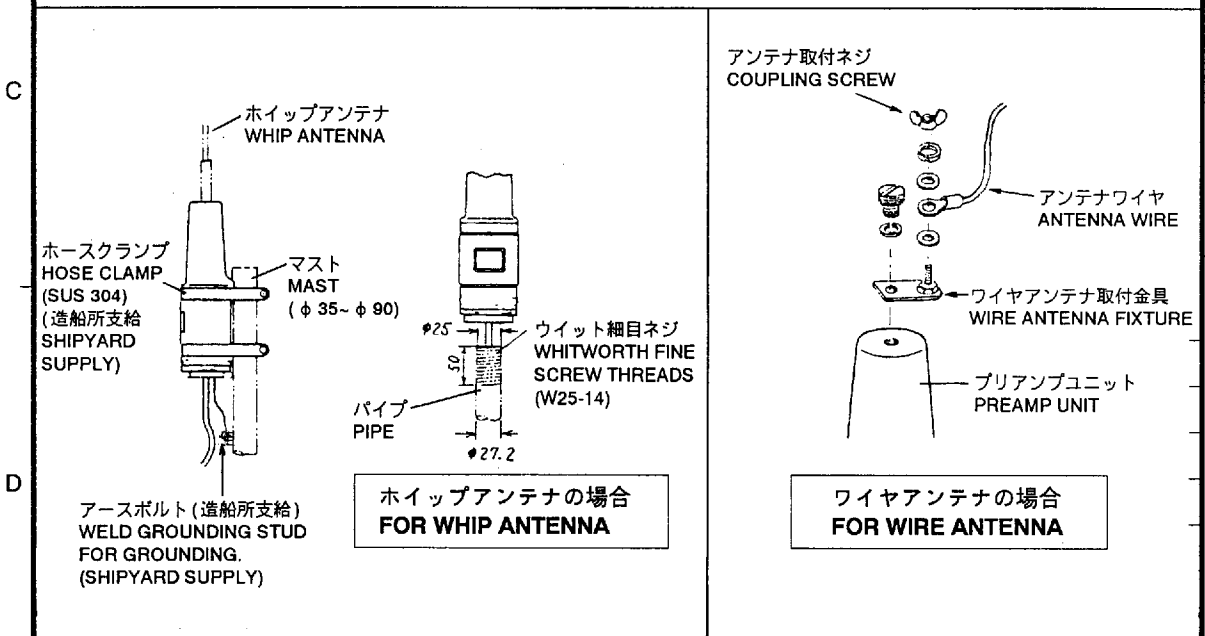
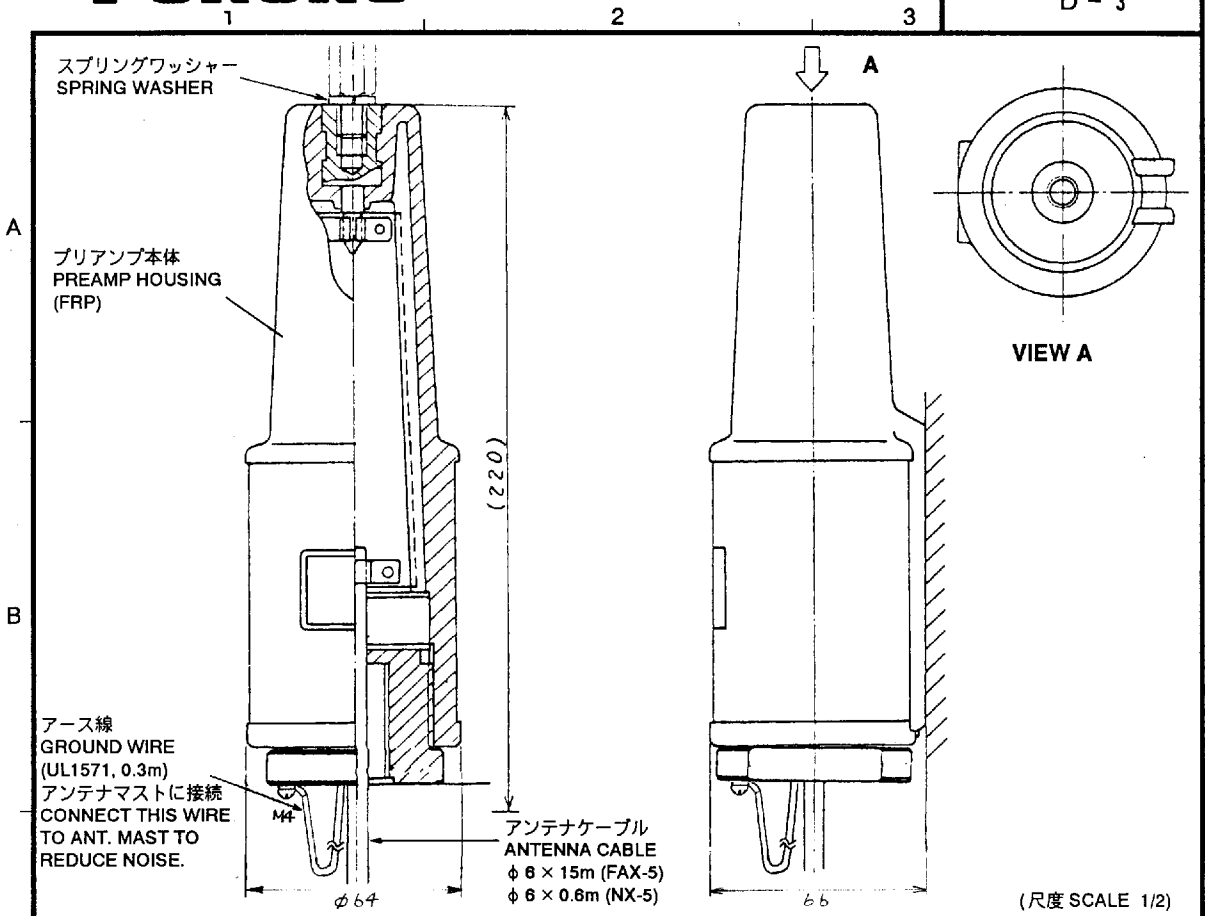

REMARKS				TYPE	FAX5 NX5
				名称	プリアンプユニット
DRAWN	APPROVED	NX-500		NAME	PREAMP UNIT
T.Y.	11/26/84	FAX-*		DWG NO.	C6244-003- H
SCALE	MASS	APPLICABLE TO;	BLOCK NO.		
X	0.6 kg	(MODEL)			

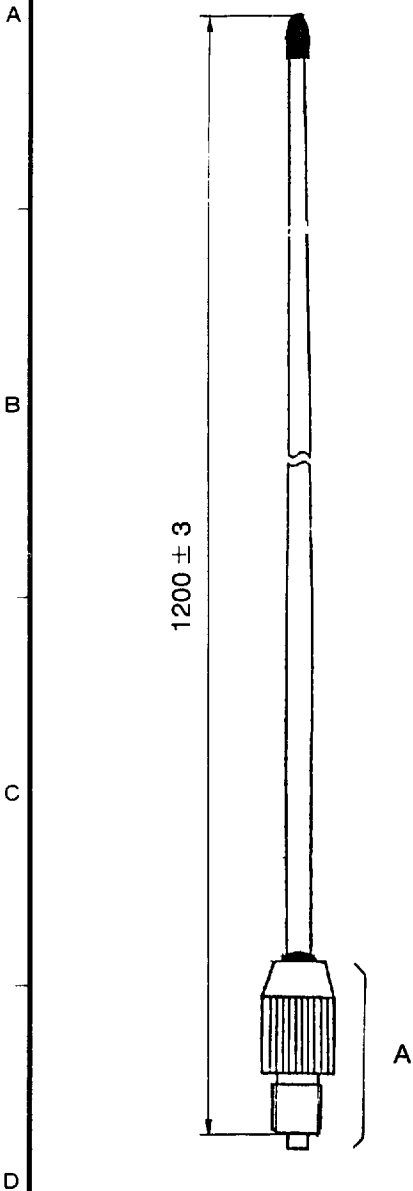

A部詳細 DETAIL A

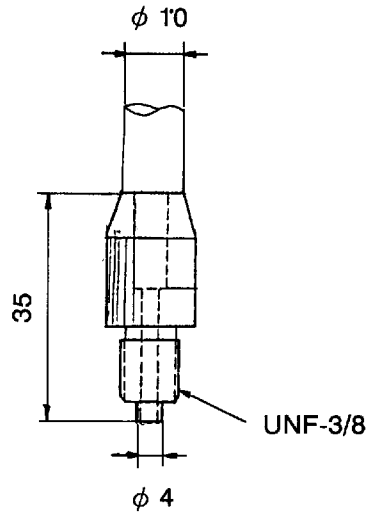

REMARKS			TYPE	FAW-1.2
			名称	1.2m ホイップアンテナ
DRAWN	APPROVED	NX-600	NAME	1.2M WHIP ANTENNA
T.Y	SEPT 14 1994 IKEBA	NX-500	DWG NO.	C5509-G03-
SCALE	MASS	APPLICABLE TO:	BLOCK NO.	B
X	0.5 kg	(MODEL)		

NO.	NAME	TYPE	CODE NO.
1	PANEL ASSY.	NX - 500	004 - 511 - 360
2	PRINTER	STP411G - 320	000 - 115 - 744
3	POWER BOARD	08P3154	004 - 511 - 530
4	MAIN BOARD	08P3151	004 - 511 - 510
5	TB BOARD	08P3152	004 - 511 - 520
6	NAV RCV BOARD	08P3119A	004 - 511 - 500
7	GASKET	22 - 008 - 0104	100 - 103 - 131
8	RUBBER BUSH	07 - 005 - 0068	700 - 500 - 680

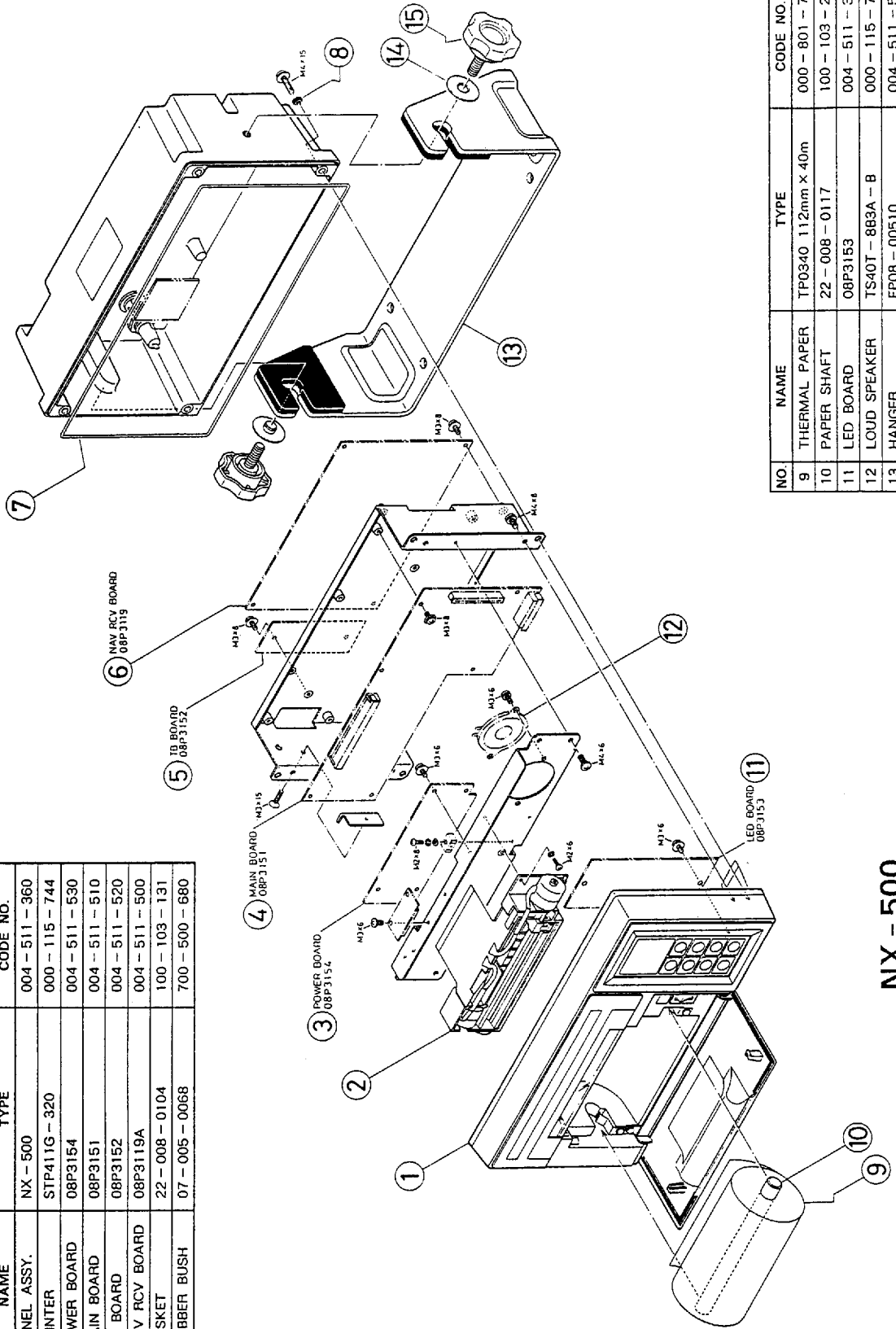

NO.	NAME	TYPE	CODE NO.
9	THERMAL PAPER	TP0340 112mm x 40m	000 - 801 - 765
10	PAPER SHAFT	22 - 008 - 0117	100 - 103 - 270
11	LED BOARD	08P3153	004 - 511 - 360
12	LOUD SPEAKER	TS40T - 883A - B	000 - 115 - 757
13	HANGER	FF08 - 00510	004 - 511 - 550
14	HANGER WASHER	05 - 029 - 0132 - 1	100 - 087 - 911
15	KNOB BOLT	KG - B2 M8 x 20 SUS	000 - 800 - 418

NX - 500
EXPLODED VIEW

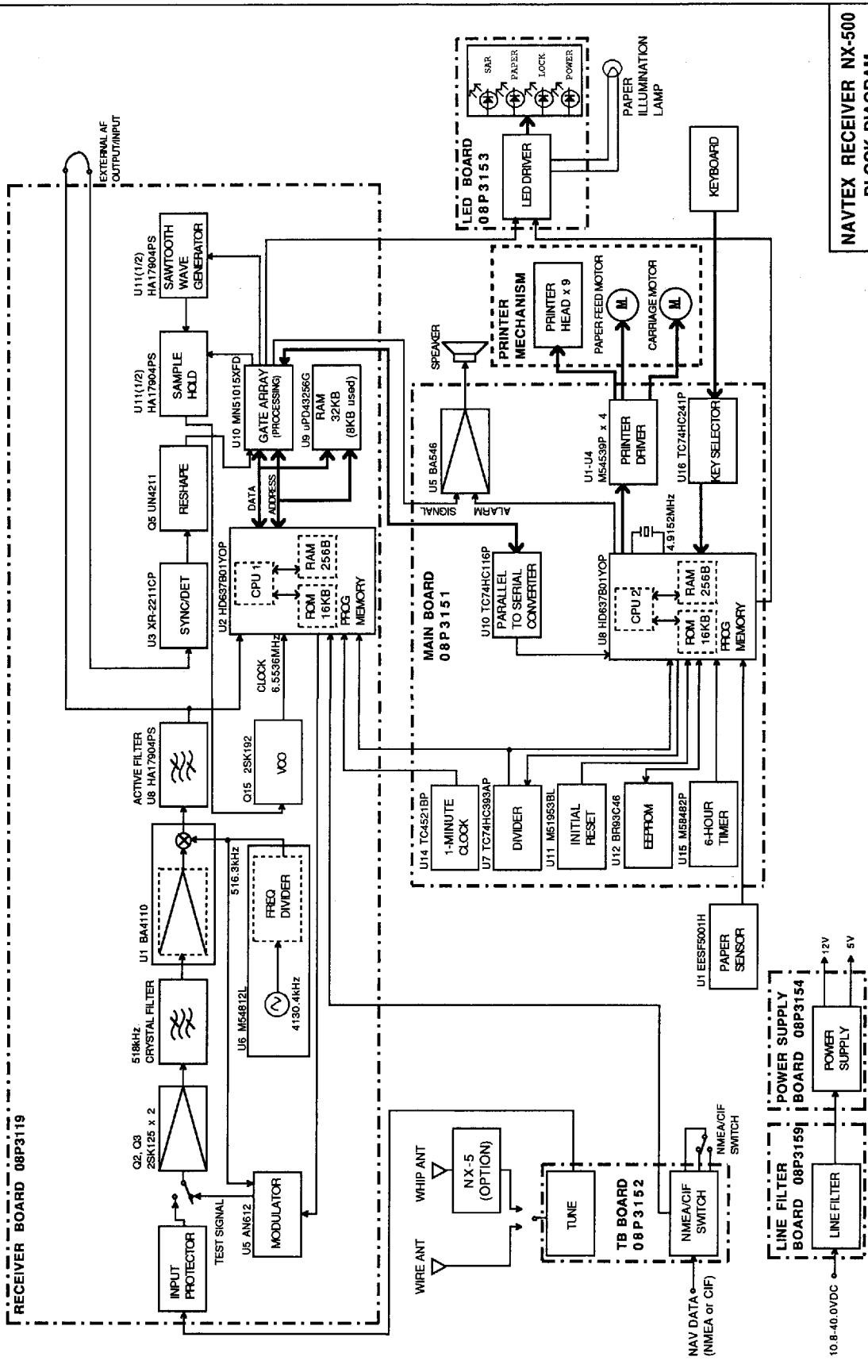

NAVTEX RECEIVER NX-500
BLOCK DIAGRAM

DWGNO. C 5 5 0 9 - B 0 1 - B

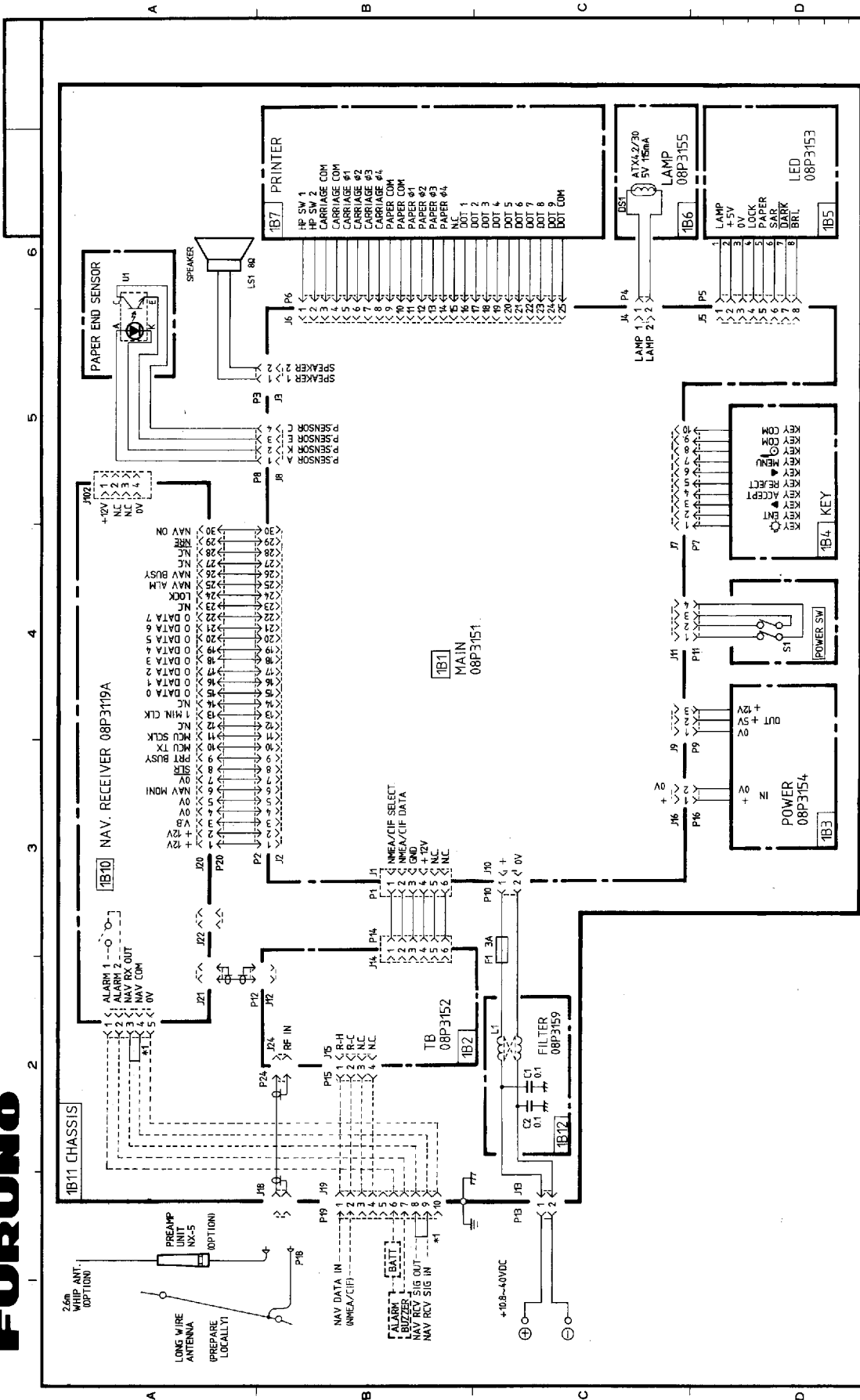

承認 APR-25-79	名 称 TITLE
検 査 APR-25-79	検査 CHECKED
製 図 M. KEDA	製 図 DRAWN
	国 番 DWG. NO.

NX-500 ナブテックス受信機
NAVTEX RECEIVER

C5509-K03-B

NX-500

*1 PUT LINK FOR NORMAL RECEPTION. "NAV RCV SIG IN/OUT" ARE PREPARED FOR CONNECTION WITH DIGITAL AUDIO TAPE RECORDER, ETC.

A
B
C
D

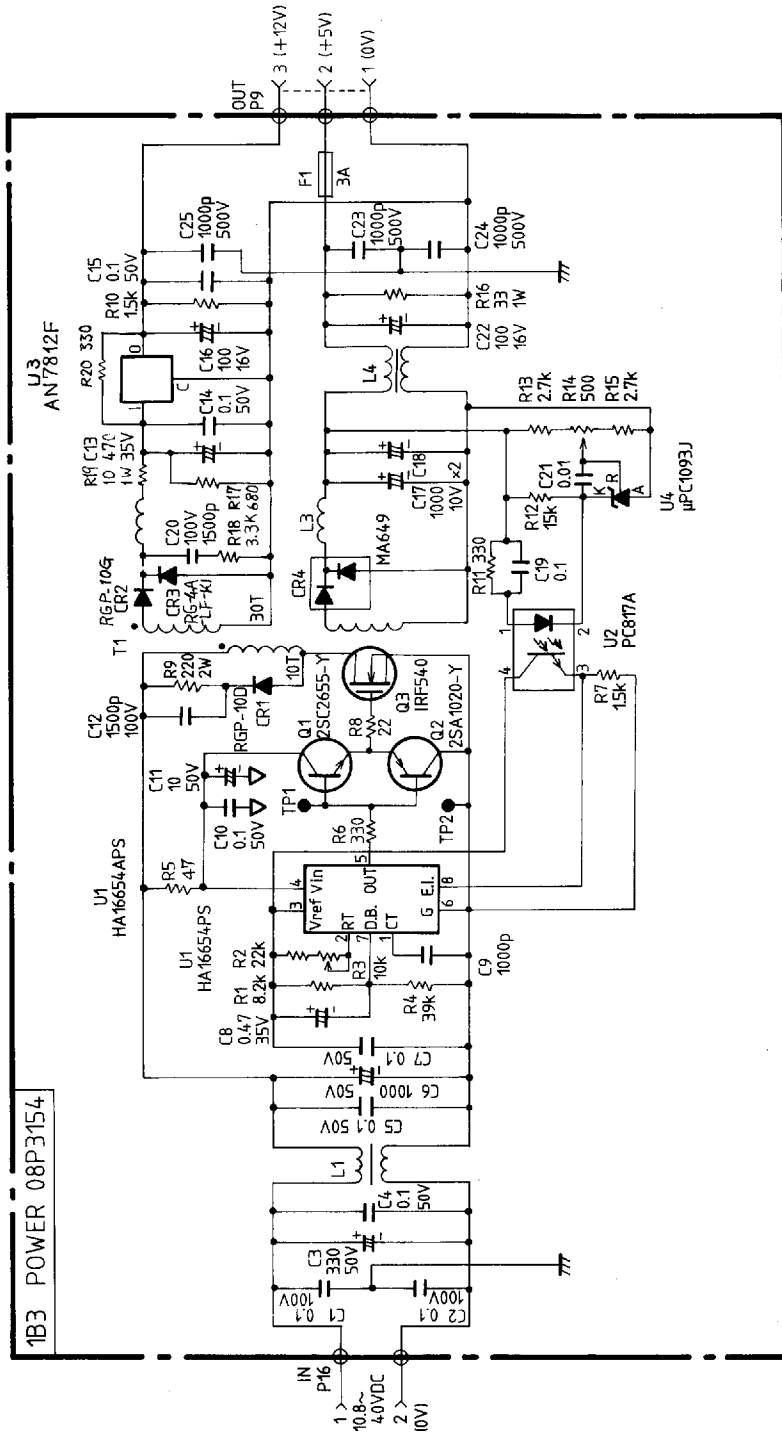

NX-500		品番 ITEM	品名 NAME	材質 MATERIAL	数量 Q'TY	図番 DWG.NO.	摘要 REMARKS
承認 APPROVED	APR. 25. '89 T. NAKAGO		三角法 THIRD ANGLE PROJECTION	名称 TITLE			
検 CHECKED	APR. 25. '89 M. IKEDA		尺度 SCALE			08P3154 電源基板 POWER BOARD	
製 DRAWN	APR. 25. '89 M. IKEDA		重量 WEIGHT	kg	図番 DWG.NO.	C5509-K05-D	

A
B
C
D

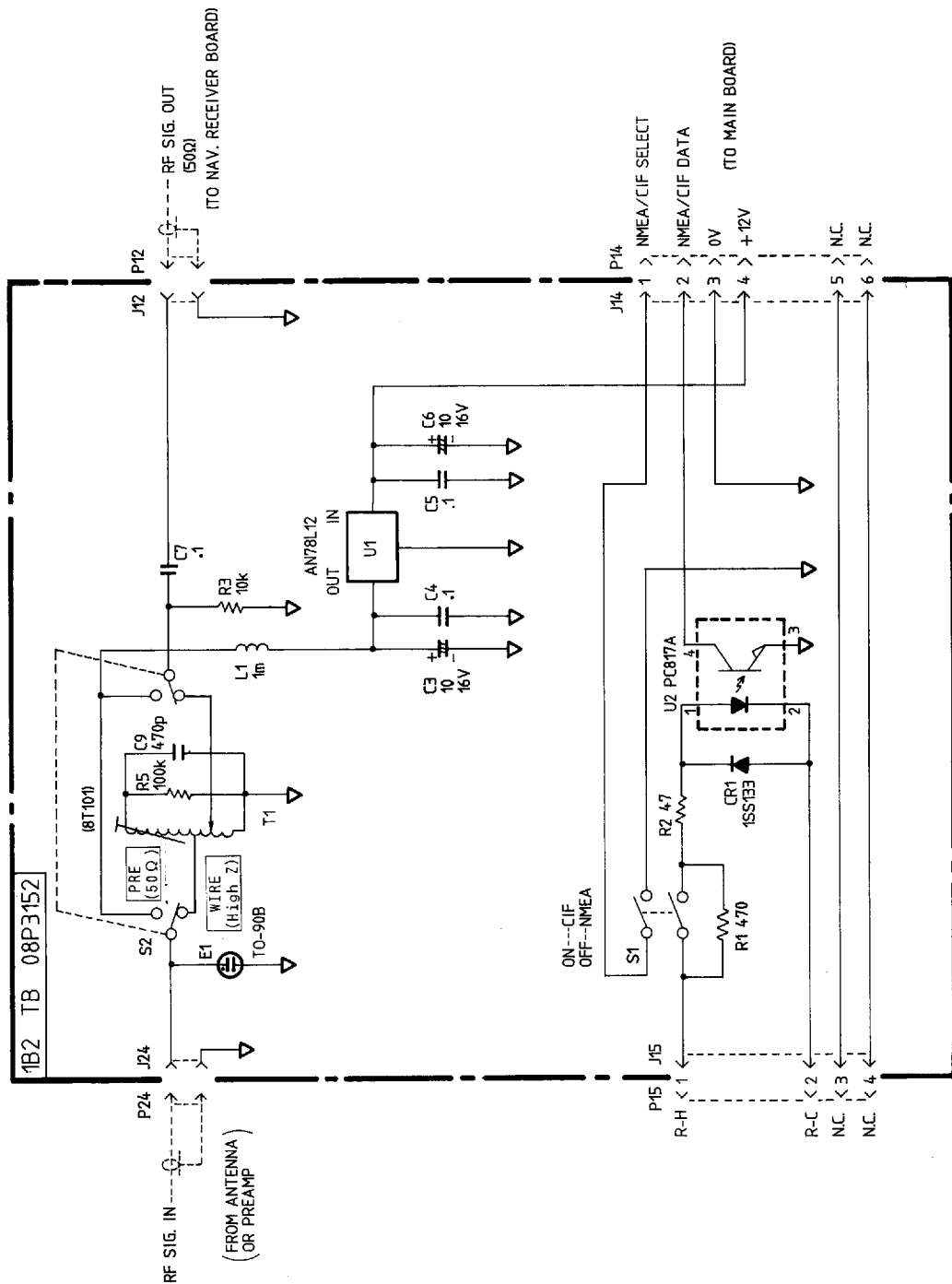

NX-500

品番 ITEM	品名 NAME	材質 MATERIAL	数量 Q'TY	図番 DWG.NO.	摘要 REMARKS
------------	------------	----------------	------------	---------------	---------------

承認 APPROVED	APR. 25. 89 T. WAKAHO	三角法 THIRD ANGLE PROJECTION	名称 TITLE	08P3152 TB 基板 BOARD	
検図 CHECKED	APR. 25. 89 M. IKEDA	尺度 SCALE			
製図 DRAWN	APR. 25. 89 M. CSAKO	重量 WEIGHT	kg	図番 DWG.NO.	C5509-K04-C

COMMAND HIERARCHY

The flow chart below shows configuration of commands provided in the NX-500. It is useful if you forget at which command level you are, or if you would like to move to another user setting. Most command levels selected at Main Menu revert to the Main Menu after selecting ESCape.

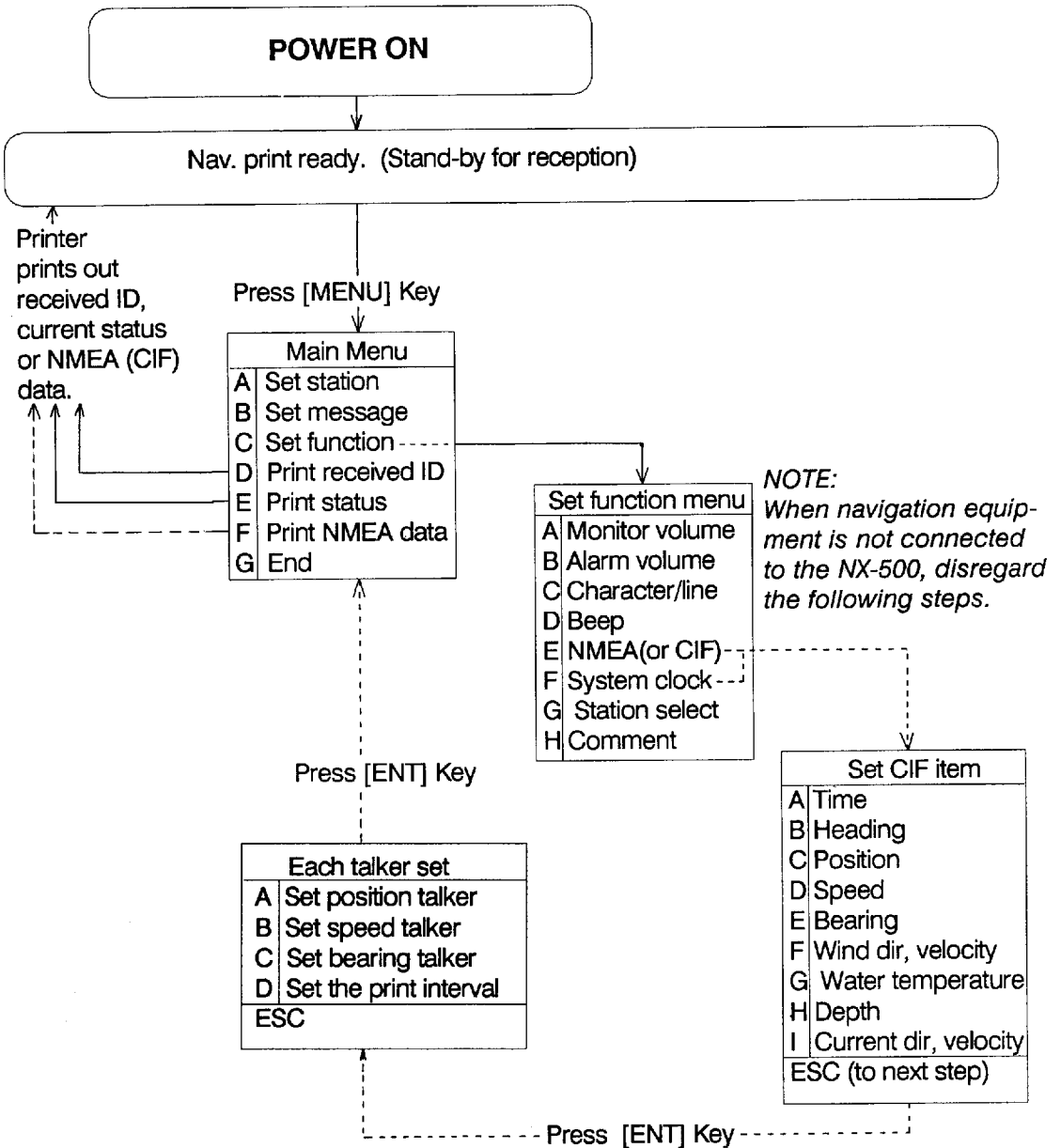

SUMMARY OF USER SETTING

IF YOU WANT TO;	STEP OF OPERATION			REFER TO PAGE
	Menu to be selected	Required setting	Then press	
select station manually.	A	Change the letters of desired stations to upper case ones.	ENT	2-8
	C	g → G (manual)	ENT	
select station automatically. (*1)	C	G → g (auto)	ENT	2-10
select message.	B	Change the letters of desired messages to upper case ones.	ENT	2-8
make louder the monitor volume.	C	a → A	ENT	2-10
make louder the SAR alarm.	C	C → c	ENT	2-10
change number of character from 70 to 35.	C	c → C	ENT	2-10
turn off the beep of key stroke.	C	D → d	ENT	2-10
print the "comment."	C	h → H	ENT	2-10
print ID Nos. of received station and message.	D	—	ENT	2-11
print set data.	E	—	ENT	2-12
print NAV data. (*1, *2)	F	—	ENT	2-13

**1: Own position data should be fed from navigation equipment.*

**2: To print NAV data, select "e (data)" and "f (clock)" in Main Menu-C.*

IMPROVEMENT OF RECEIVER S/N RATIO (Remedy for RFI)

PROBLEM

NX-500 may experience a decrease in receiver sensitivity. This may occur if the coaxial cable connected between the optional preamp unit and the main unit is extended by the use of an extension cable.

CAUSE

The outer conductor of the coaxial cable picks up unwanted signal/noise.

OUTLINE OF FIELD MODIFICATION

Connect a vinyl ground wire between the shield of the coaxial cable at the base of the preamp unit and the mast. Figures 1 and 2 on the next page illustrate how to do this modification.

NOTE: The coaxial cable should not be laid close to or bound with power cables or control cables.

MODIFICATION REQUIRED/NOT REQUIRED

Required

- 1) If most of the original supply coaxial cable is outside of the mast.
- 2) Extension cable is used.
- 3) Where RFI/noise is a problem.

Not Required

- 1) Coaxial cable runs inside a steel mast or conduit.
- 2) Where the original supply coaxial cable has been replaced (or can be replaced) with one having an armor.
- 3) For FRP ships and non-metallic masts where a good ground cannot be made at the base of the preamp unit.
- 4) If the coaxial cable can be shortened.

FACTORY-MODIFIED SETS

This modification will be made on the corresponding sets produced from February 1990. If the factory-added ground wire is not long enough, run an additional ground wire between the ground terminal and the mast. See the figure below.

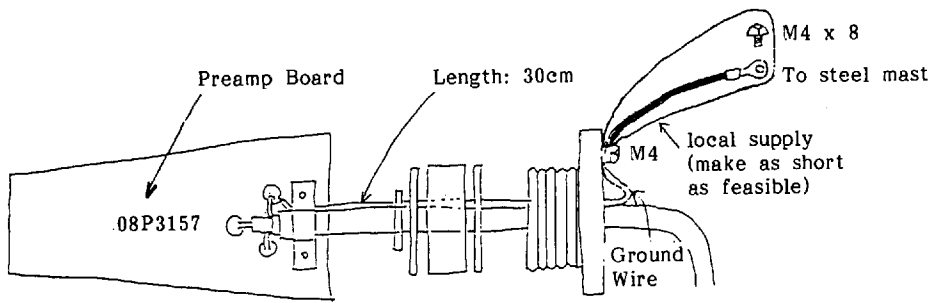

Fig. 1

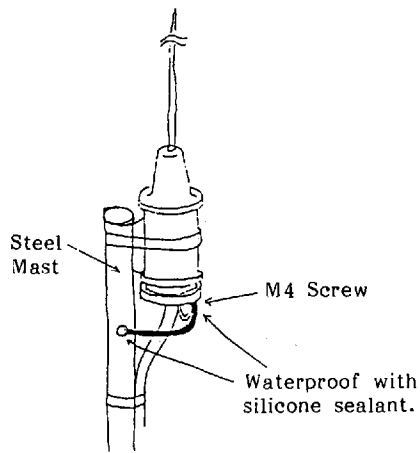

Fig. 2

FURUNO®**FURUNO ELECTRIC CO., LTD.**

9-52 Ashihara-Cho, Nishinomiya City, 662-8580, Hyogo, Japan

Tel: +81 798-65-2111 Fax: +81 798-65-4200

Pub NO. DOC-241

Declaration of conformity to type

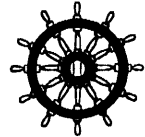
We **FURUNO ELECTRIC CO., LTD.**-----
(Manufacturer)

9-52 Ashihara-Cho, Nishinomiya City, 662-8580, Hyogo, Japan

(Address)

hereby declare under our sole responsibility that the product

NAVTEX receiver model NX-500 consisting of NAVTEX receiver NX-500, Active antenna (pre-amplifier built-in) NX-5 and AC power supply unit (Rectifier) PR-62

(Model names, type numbers)

to which this declaration relates conforms to the following standard(s) or normative document(s)

ETS 300 .65: September 1998 Amendment 1
EN 60945: January 1997 (IEC 60945 Third edition: 1996-11)
EN 301 011: September 1998-----
(title and/or number and date of issue of the standard(s) or other normative document(s))

For assessment, see EC type-examination certificate N° KCS/99212010/AA/00 of 10 August 1999 issued by KCS Certification, The Netherlands

This declaration is issued according to the provisions of European Council Directive 96/98/EC on marine equipment modified by Commission Directive 98/85/EC.

On behalf of Furuno Electric Co., Ltd.

Hiroaki Komatsu
Manager,
International Rules and RegulationsNishinomiya City, Japan
August 17, 1999-----
(Place and date of issue)-----
(name and signature or equivalent marking of authorized person)