

# FURUNO

## OPERATOR'S MANUAL

ECHO SOUNDER

MODEL FE-606



**FURUNO ELECTRIC CO., LTD.**  
NISHINOMIYA, JAPAN

©FURUNO ELECTRIC CO., LTD.

9-52, Ashihara-cho,  
Nishinomiya, Japan 662

Telephone: 0798-65-2111  
Telefax: 0798-65-4200

•Your Local Agent/Dealer

All rights reserved.

Printed in Japan

FIRST EDITION : AUG 1982  
M : AUG. 21, 1998

(TATA)

PUB. No. OME-22790  
FE-606



\*00080666800\*



# SAFETY INSTRUCTIONS

"**DANGER**", "**WARNING**" and "**CAUTION**" notices appear throughout this manual. It is the responsibility of the operator and installer of the equipment to read, understand and follow these notices. If you have any questions regarding these safety instructions, please contact a FURUNO agent or dealer.



**DANGER**

This notice indicates a potentially hazardous situation which, if not avoided, will result in death or serious injury.



**WARNING**

This notice indicates a potentially hazardous situation which, if not avoided, could result in death or serious injury.



**CAUTION**

This notice indicates a potentially hazardous situation which, if not avoided, could result in minor or moderate injury, or property damage.



# SAFETY INFORMATION FOR THE OPERATOR

---

## **WARNING**



**Do not open the cover of the equipment.**

This equipment uses high voltage electricity which can shock, burn, or cause death. Only qualified personnel should work inside the equipment.

**Do not disassemble or modify the equipment.**

Fire, electrical shock or serious injury can result.

**Immediately turn off the power at the ship's mains switchboard if water or foreign object falls into the equipment or the equipment is emitting smoke or fire.**

Continued use of the equipment can cause fire, electrical shock or serious injury.

## **CAUTION**

**Do not place liquid-filled containers on the top of the equipment.**

Fire or electrical shock can result if a liquid spills into the equipment.

**Do not place heater near the equipment.**

Heat can melt the power cord, which can result in fire or electrical shock.

**Do not operate the unit with wet hands.**

Electrical shock can result.

**Use the correct fuse.**

Use of the wrong fuse can cause fire or equipment damage.



# SAFETY INFORMATION FOR THE INSTALLER

## **WARNING**



**Only qualified personnel should work inside the equipment.**

This equipment uses high voltage electricity which can shock, burn, or cause death.

**Turn off the power at the ship's mains switchboard before beginning the installation. Post a warning sign near the switchboard to ensure that the power will not be applied while the equipment is being installed.**

Serious injury or death can result if the power is not turned off, or is applied while the equipment is being installed.

## **CAUTION**



**Ground the equipment to prevent electrical shock and mutual interference.**

Ungrounded equipment can give off or receive electromagnetic interference or cause electrical shock.

**Confirm that the power supply voltage is compatible with the voltage rating of the equipment.**

Connection to the wrong power supply can cause fire or equipment damage. The voltage rating appears on the label at the rear of the equipment.

**C O N T E N T S**  
\* \* \* \* \*

	<u>Page</u>
FEATURES OF FE-606	0-1
OPERATION	1-1 to 1-6
1. Operating Controls and Switches	1-1
2. Paper Loading	1-5
HOW TO INTERPRET ECHOGRAM	2-1 to 2-9
What is provided on echogram	2-1
Variety of echogram with echosounder characteristics	2-2
To read more from echogram	2-5
MAINTENANCE	3-1 to 3-2
1. Stylus Replacement and Adjustment	3-1
2. Fuse Replacement	3-2
3. Cleaning	3-2
TROUBLESHOOTING	4-1 to 4-2
Appendix 1. Specifications	AP1-1 to AP1-2
Appendix 2. Installation	AP2-1 to AP2-6
Appendix 3. How to change calibration unit	AP3-1
SCHEMATIC DIAGRAMS	S-1 to S-2

## FEATURES OF FE-606

\*\*\*\*\*

The FE-606, with FURUNO's years of experience in commercial echosounders, adds many advantageous features to conventional less costly echosounders.

Thanks to new electronic devices and advanced digital signal processing technique, it provides fine and distinct recording of underwater objects. Aside its high quality recording, remarkable features of FE-606 are follows.

- \* Expanded bottom-lock recording, which is extremely useful in bottom trawling or in shell fish finding, is available together with normal recording.
- \* A bright digital display provides seabed depth at a glance.
- \* Extremely effective noise limiter without any effect on wanted echoes.

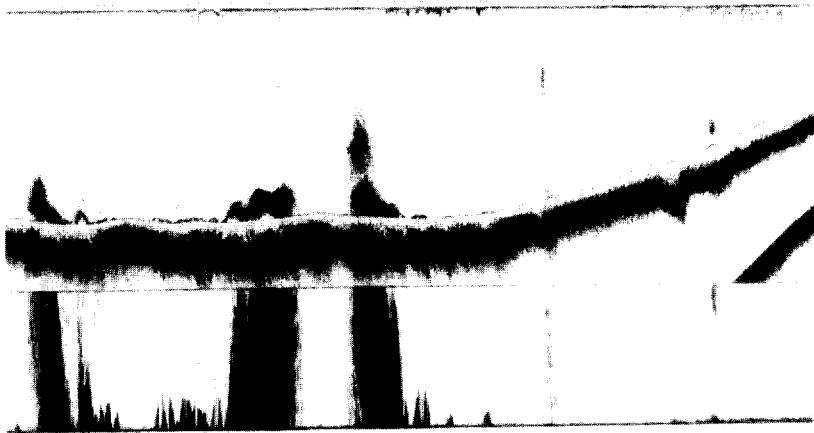
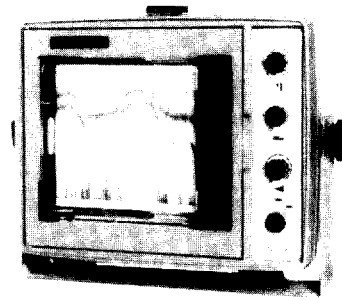

We hope you will read the following instructions and make best use of your FE-606.

(By adding slight modification, signals detected by the FE-606 can be displayed on FURUNO's FCV-200/201 Color Video Sounder and even recorded into MT-11/12 Picture Recorder.)

## OPERATION

\*\*\*\*\*

### 1. Operating Controls and Switches

Prior to reading the instructions, see the layout of the controls of the FE-606 echosounder on page 1-6.

#### [FRONT PANEL CONTROLS]

#### FUNCTION Switch

This switch has two functions: power on-off and selection of the two chart presentation modes.

The position "O" shuts off the power of the set. Use this position to stop recording or to load new paper.

Turning this switch to "■" (normal) provides normal recording over the full paper width.

Turning this to "▣" (bottom-lock) provides compressed normal recording on the upper 2/3 of paper width and an expanded bottom-lock recording on the rest. The **SHADOW LINE** control must be adjusted properly to ensure accurate bottom-lock recording. The bottom-lock range is always 5m (15ft or 2.5fam/braza/passi) irrespective of the depth range setting.

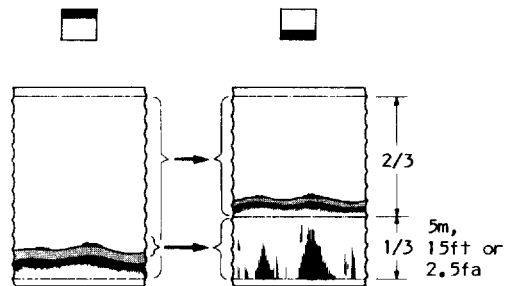
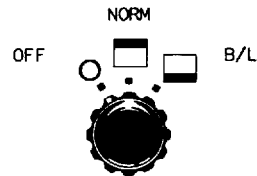

#### RANGE Switch

This selects the depth range to be recorded on the paper. The basic range is doubled step-by-step by turning it from 1 to 6. The "b" position on each range is a 50%-phased range with respect to the basic "a" range. Refer to table below.

BASIC PHASED	1		2		3		4		5		6	
	a	b	a	b	a	b	a	b	a	b	a	b
Meters	0   10	5   15	0   20	10   30	0   40	20   60	0   100	50   150	0   200	100   300	0   400	200   600
Feet	0   30	15   45	0   60	30   90	0   120	60   180	0   300	150   450	0   600	300   900	0   1200	600   1800
Fathoms Brazas Passis	0   5	2.5   7.5	0   10	5   15	0   20	10   30	0   50	25   75	0   100	50   150	0   200	100   300

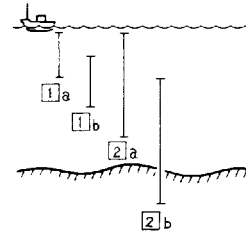
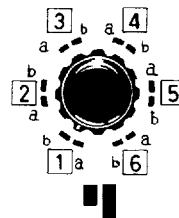



## GAIN Control

Turning this clockwise increases the sensitivity of the receiver. Use higher gain for deep sea operations, and lower gain in shallow waters.

The table at right gives general guidelines for gain settings on range chosen and frequency of operation.

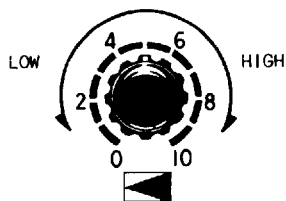

RANGE	GAIN	
	50kHz	200kHz
1	2 to 3	2 to 4
2	3 to 4	3 to 5
3	4 to 5	4 to 6
4-6	5 to 10	

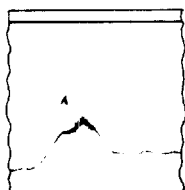

GAIN too low



GAIN optimum



GAIN too high

## SHADOW LINE Control

This control is used for discriminating fish or other targets just above the seabed. (This function is also known as "whiteline" or "grayline" in other machines.)

After the GAIN control has been adjusted (with the SHADOW LINE off) for a good bottom recording, turn the SHADOW LINE control slowly clockwise to give a gray "shadow" just under the top of the seabed echo. Now fish will show distinctly above the seabed even if they close to the bottom.

Too far a clockwise setting of this control can blank fish echoes, and the correct depth reading or bottom-lock operation may be affected.

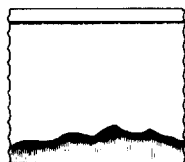
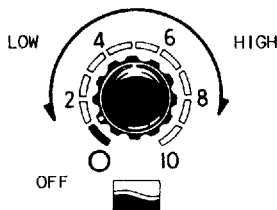

SHADOW LINE "OFF"

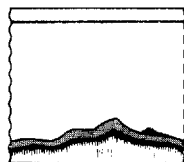

SHADOW LINE optimum

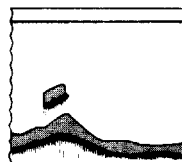

SHADOW LINE too high

## Upper & Lower Readouts

With the SHADOW LINE control at "O" (off) position, the upper and lower readouts show the start and end depths of the recording range selected by the RANGE selector.

With the SHADOW LINE control turned clockwise, the lower readout is changed to show the seabed depth.

However, if there is strong interference from other echosounders nearby or if a very dense fish school is encountered, the depth reading may become unstable momentarily. This condition may mean that excessive Shadow Line/Gain is used.

Some of the decimal points on the lower readout are used as alarm indicators.

The one on the left is an "overflow" indicator that lights when the reading has gone over "999". This may happen in deep water operation when using the foot-scale calibration.

The one on the right is a "low signal" indicator that flickers when the signal is too weak to allow proper shadow line operation. This is to alert the operator that the seabed depth shown on the lower readout may not be reliable.

The one in the center is merely a decimal point.

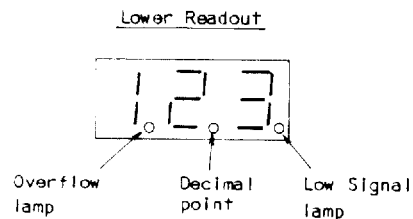
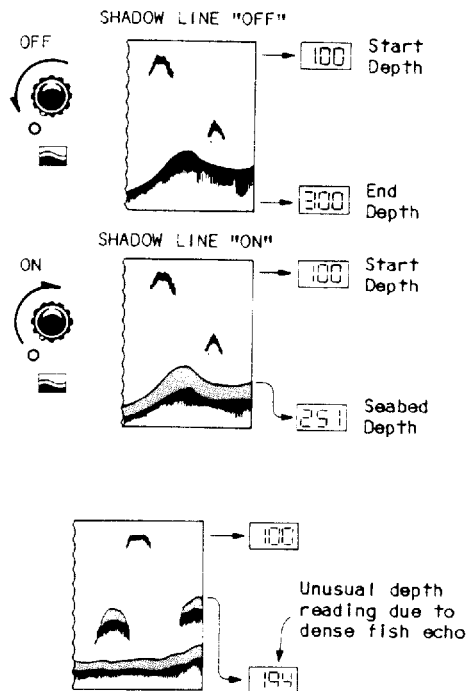

Ex. "1.23" ---- 1123(feet)

Ex. "123." ---- Reading not reliable.

**[PRESET CONTROLS]**  
- inside the cabinet -

**DRAFT Control**

This adjusts the position of zero line on the paper. The primary purpose of this control is to read the true depth from sea surface, taking the ship's draft into account.

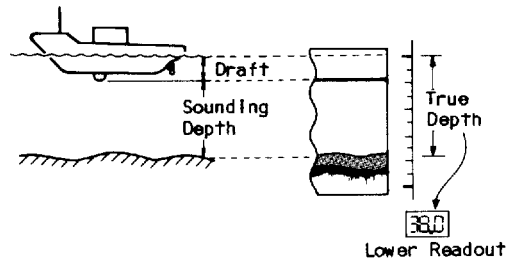

This may also be used to shift the recording area downward to use the paper twice or more times. However, the following points should be noted.

- a. This method does not work on the phased ("b") ranges.
- b. Multiple recordings may be confusing to read.

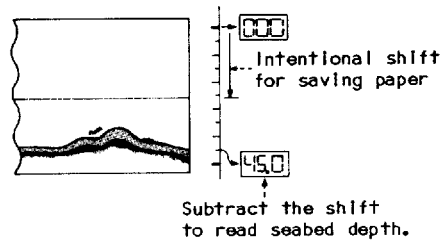

**TVG control**

The TVG control is used to compensate for the effect of propagation loss of sound energy in water, suppressed gain just after transmission and increasing gain as time (range) increases. Too far a clockwise setting will miss weak targets in shallow/mid water.

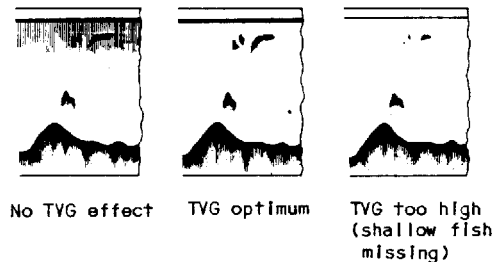

**NOISE LIMITER Switch**

With this switch turned "ON", random interference or noise can be minimized.

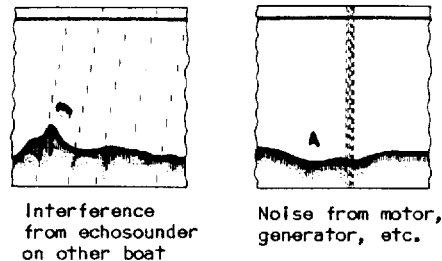

**PAPER SPEED Switch**

This selects the paper sending speed, at 3, 6 or 10mm/sec. Select the optimum speed, taking depth range and ship's speed into account. A guideline for paper speed setting is shown at right.

SPEED	RANGE
Fast	1a to 4b
Medium	5a to 6a
Slow	6b

**POWER REDUCTION Switch**

This selects the output power of the sounding pulse. Use high power "⌋" for normal use. Occasionally low power "⌋" position is needed in extremely shallow water, or on congested fishing grounds to minimize interference to other boats.

## SCALE PLATE CALIBRATIONS

### [ METERS ]

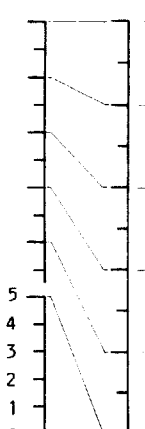

	1a	1b	2a	2b	3a	3b	4a	4b	5a	5b	6a	6b
0	0	5	0	10	0	20	0	50	0	100	0	200
1	1	6	2	12	4	24	10	60	20	120	40	240
2	2	7	4	14	8	28	20	70	40	140	80	280
3	3	8	6	16	12	32	30	80	60	160	120	320
4	4	9	8	18	16	36	40	90	80	180	160	360
5	5	10	10	20	20	40	50	100	100	200	200	400
6	6	11	12	22	24	44	60	110	120	220	240	440
7	7	12	14	24	28	48	70	120	140	240	280	480
8	8	13	16	26	32	52	80	130	160	260	320	520
9	9	14	18	28	36	56	90	140	180	280	360	560
10	10	15	20	30	40	60	100	150	200	300	400	600

### [ FEET ]

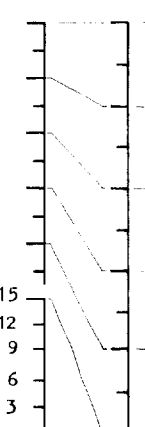

	1a	1b	2a	2b	3a	3b	4a	4b	5a	5b	6a	6b
0	0	15	0	30	0	60	0	150	0	300	0	600
3	3	18	6	36	12	72	30	180	60	360	120	720
6	6	21	12	42	24	84	60	210	120	420	240	840
9	9	24	18	48	36	96	90	240	180	480	360	960
12	12	27	24	54	48	108	120	270	240	540	480	1080
15	15	30	30	60	60	120	150	300	300	600	600	1200
18	18	33	36	66	72	132	180	330	360	660	720	1320
21	21	36	42	72	84	144	210	360	420	720	840	1440
24	24	39	48	78	96	156	240	390	480	780	960	1560
27	27	42	54	84	108	168	270	420	540	840	1080	1680
30	30	45	60	90	120	180	300	450	600	900	1200	1800

### [ FATHOMS/BRAZAS/PASSIS ]

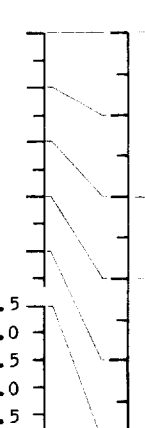

	1a	1b	2a	2b	3a	3b	4a	4b	5a	5b	6a	6b
0	0	2.5	0	5	0	10	0	25	0	50	0	100
0.5	0.5	3.0	1	6	2	12	5	30	10	60	20	120
1.0	1.0	3.5	2	7	4	14	10	35	20	70	40	140
1.5	1.5	4.0	3	8	6	16	15	40	30	80	60	160
2.0	2.0	4.5	4	9	8	18	20	45	40	90	80	180
2.5	2.5	5.0	5	10	10	20	25	50	50	100	100	200
3.0	3.0	5.5	6	11	12	22	30	55	60	110	120	220
3.5	3.5	6.0	7	12	14	24	35	60	70	120	140	240
4.0	4.0	6.5	8	13	16	26	40	65	80	130	160	260
4.5	4.5	7.0	9	14	18	28	45	70	90	140	180	280
5.0	5.0	7.5	10	15	20	30	50	75	100	150	200	300

## 2. Paper Loading

During operation, an end mark will eventually appear on the bottom of the paper. This is to warn that the paper is running out, and you will need a new roll of paper soon.

Change the paper roll, following the procedure below.

1. Turn the FUNCTION switch to "O" (off).

2. Open the front door.

3. Move the stylus behind the recording plate, if it is in front, and swing the recorder assembly down.

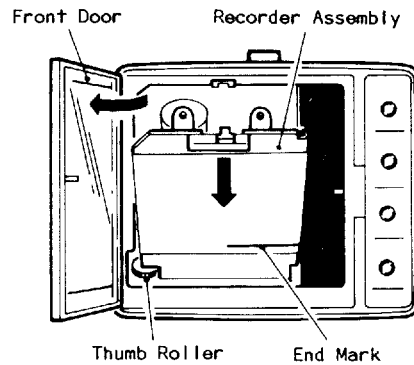

4. Pull down the paper holder flaps and remove the used paper and spools.

5. Put a new roll of paper into the feed holder and an empty spool into the take-up holder. Then pass the paper over the recording plate and insert the end into the spool slot, or tape the end squarely to the spool.

Roll the paper 3 to 4 turns so that it will not come loose.

6. Carefully push the recorder assembly backwards until you feel it engage fully.

7. Turn the thumb roller to smooth out the paper over the recording plate.

8. Close the front door again.

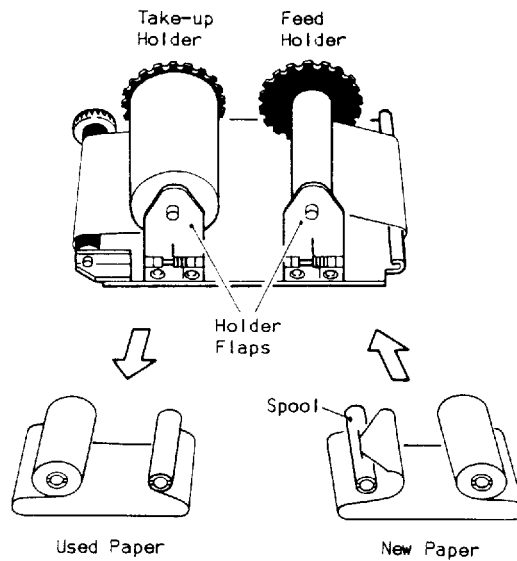

## Front Panel Controls

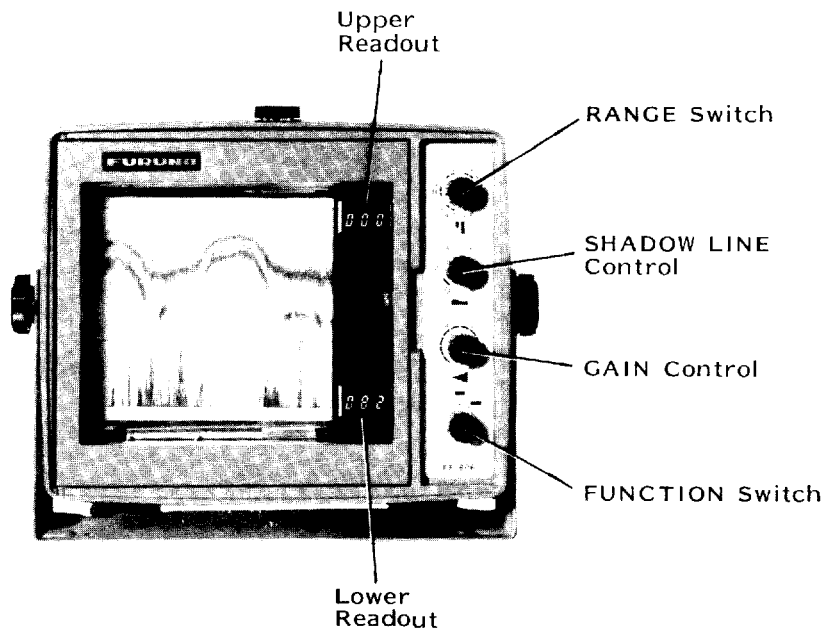

## Preset Controls

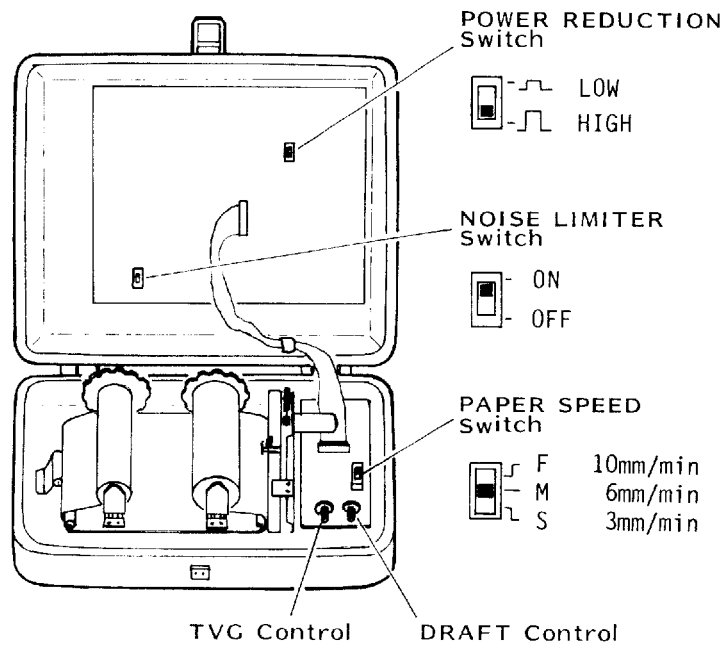

**HOW TO INTERPRET ECHOGRAM**

\*\*\*\*\*

[ What is provided on echogram ]

**Transmission Line**

The transmission line is a trace of ultrasonic wave emitted into the water. We often call this line as "Zero Line", however, it indicates not the sea surface but the ship's hull bottom where the transducer is mounted. To know the depth of a target, the ship's draft must be added to the sounding depth. In small boats, this line may be taken as sea surface.

The transmission line can not be seen in a phased range.

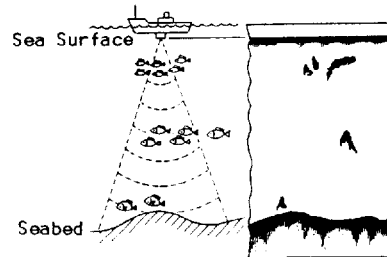

**Seabed**

The seabed is recorded as comparatively dark trace with some width. Its intensity and width vary with the nature of seabed and characteristics of the echosounder (frequency, pulselength and receiver characteristics).

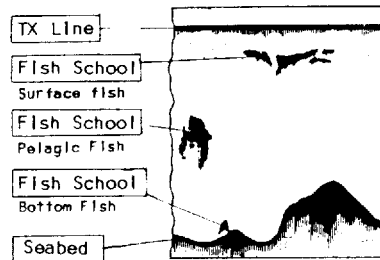

**Fish School**

The fish school is recorded between the transmission line and seabed (the transmission line is invisible in phased ranges). The shape and size of the fish school trace largely depends on the characteristics of echosounder and habits of fish species.

In the "bottom-lock" mode, echoes just above the seabed are expanded in the lower part of paper.

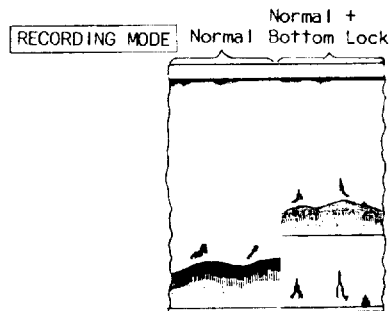

[ Variety of echogram with echosounder characteristics ]

Feature of echogram is affected to a great extent by the characteristics of the echosounder.

### Frequency

Characteristics of ultrasonic pulse vary as tabulated below with its frequency, and provides a different type of echogram.

Frequency	Low Frequency	High Frequency
Characteristics, Application		
Beamwidth*	Wide**	Narrow
Sounding Depth	Deep	Shallow
Resolution***	Poor	Good
Affection of Air Bubbles and Water Noise	Large	Little
Suitable Application	<ul style="list-style-type: none"> <li>•Wide area searching</li> <li>•Bottom discrimination</li> </ul>	<ul style="list-style-type: none"> <li>•Identification of fish school density</li> <li>•Discrimination of bottom fish</li> </ul>

\*Sound pressure of ultrasonic wave is strongest at the center of the beam and goes weaker gradually in the outer part. The beamwidth is the angle of conical beam measured at half pressure points of ultrasonic wave. (Echoes outside the beam can also be recorded if the reflection is strong)

\*\*The beamwidth is, strictly speaking, determined by the size of transducer face. Even in low frequency, it becomes narrower if two or more transducers are placed side by side.

\*\*\*Ability to distinguish two fish schools closely located at the same depth.

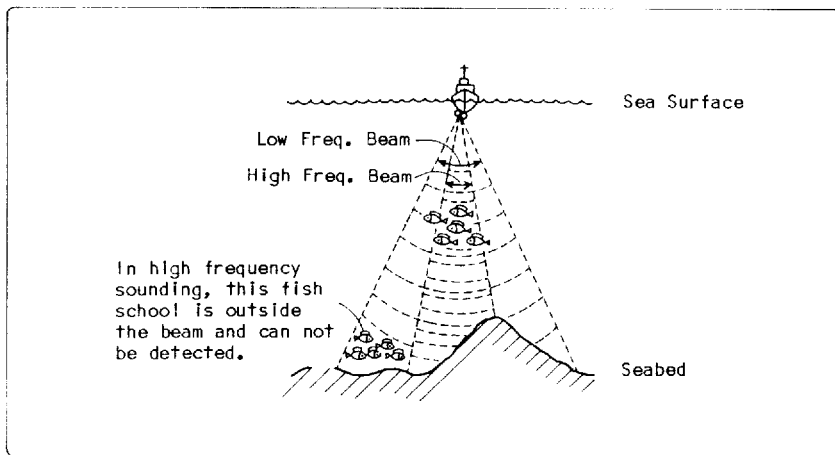



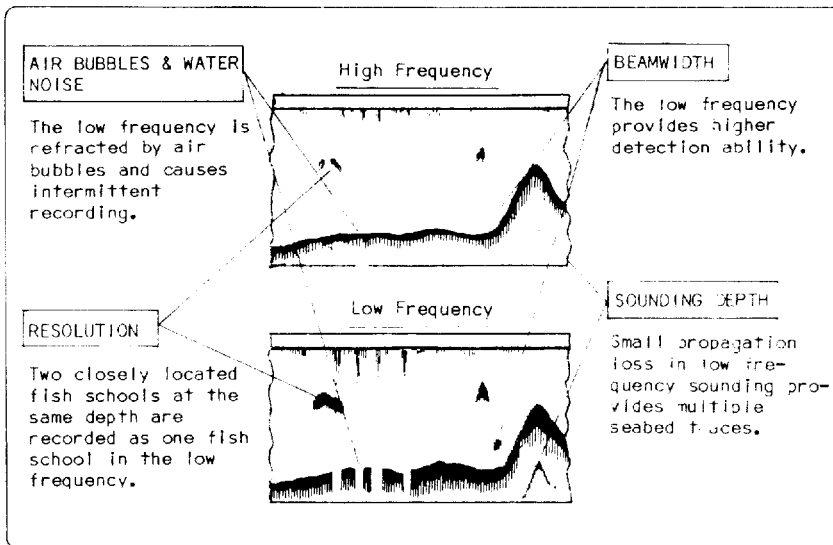

**Pulselength**

Characteristics of echogram change with pulselength as follows.

Pulselength	Short	Long
Feature, Application		
Range Resolution*	Good	Poor
Sounding Ability**	Poor	Good
Suitable Application	<ul style="list-style-type: none"> <li>Discrimination of fish distribution</li> <li>Identification of bottom fish</li> </ul>	<ul style="list-style-type: none"> <li>Deep sounding</li> <li>Detection of small fish school</li> </ul>

\*Ability to distinguish two fish schools closely located at different depths.

\*\*Sounding depth and ability to detect small target.

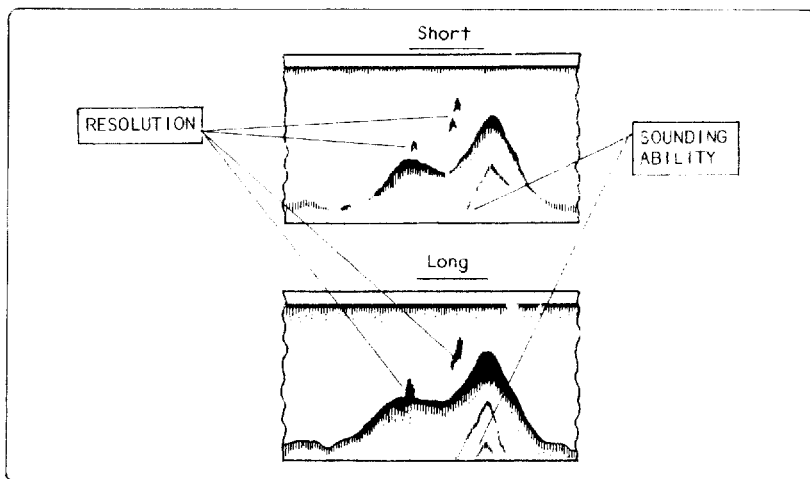

**Sounding Rate and Paper Speed**

Paper speed and sounding rate are closely related to the density of recordings. The slower paper speed and higher sounding rate make the recording higher in density.

Since characteristics of fish school trace or seabed trace on the echogram change with paper speed and ship's speed as shown below, they should be taken into account for interpretation of the echogram.

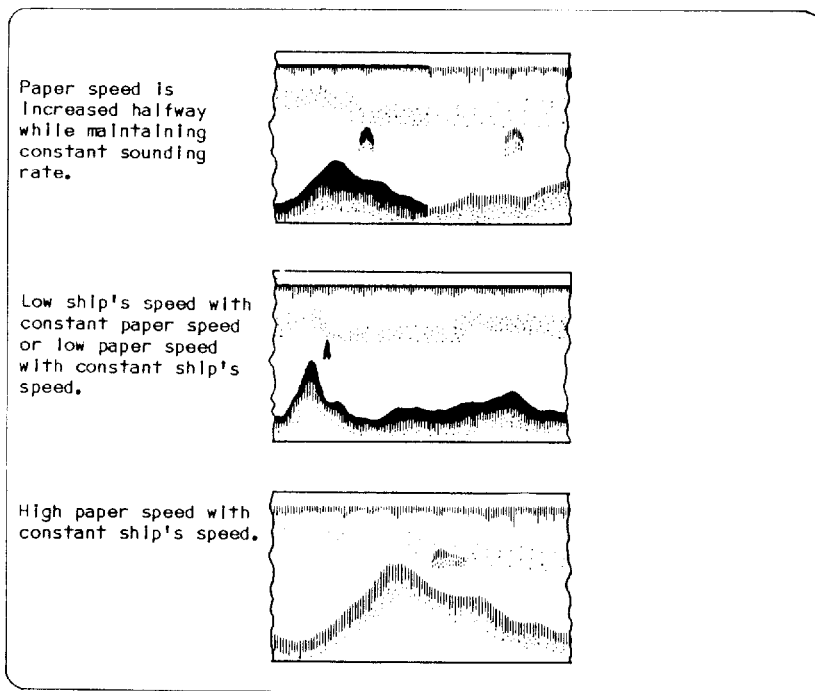

[ To read more from echogram ]

## Fish quantity/Fish School Density

Quantity of fish can be estimated to a certain extent from the trace of fish school. Estimation is based on the following two factors.

### \* Size of fish school trace

Since size of fish school trace is proportional to the size of actual fish school, it can be used as a basis. However, it should be taken into account that if two traces appear at different depths with the same size, the fish school at shallower depth is actually bigger than that at deeper depth.

The sounding beam of an echosounder is conical. This indicates that a fish school in a deeper water is hit by the beam for an extended period of time and leaves a wider trace, that is, the trace becomes bigger than the actual size of fish school.

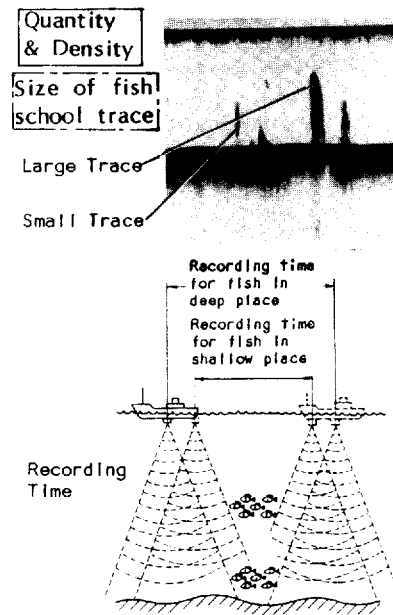

### \* Intensity of fish trace

Intensity of echo trace is the other basis to estimate fish quantity. In two fish schools of the same size, densely concentrated fish school returns stronger echoes and provides darker trace. However, it should also be kept in mind that if two traces are recorded at different depths with the same intensity, the fish school at deeper place is more densely concentrated.

Since the ultrasonic wave attenuates as it propagates, the trace of a fish school in a deep place becomes weaker than that in shallow place even if they reflect the same amount of wave.

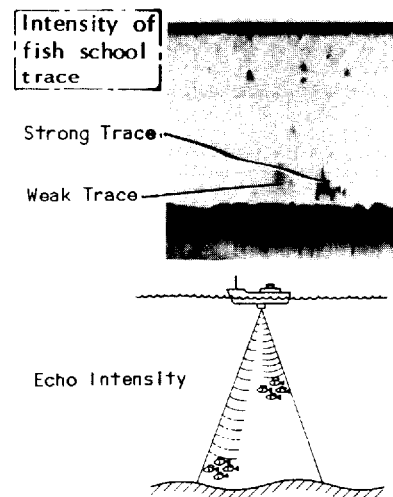

**Plankton Layer (DSL)**

Cloud-like layer is sometimes registered between the transmission line and seabed. This is a mass of micro organism called plankton. Since fish gather to feed on it as bait, fishing operation of some species of fish is conducted by just observing this trace rather than the trace of aiming fish. Usually the plankton layer lies in deep water by day and rises to shallow water at night.

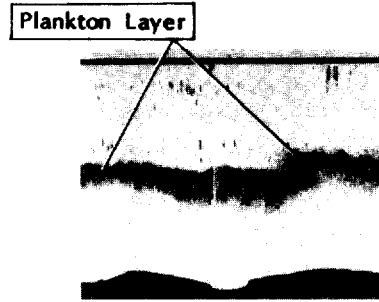

**Current Rip**

Trace which can be mistaken apparently as noise is plotted in the place called current rip, where two ocean currents meet with different speeds, direction and water temperatures each other. This noise-like trace is either air bubbles or plankton layer. Since fish gather there in search for bait, discrimination of current rip is an important means for finding out a fish school.

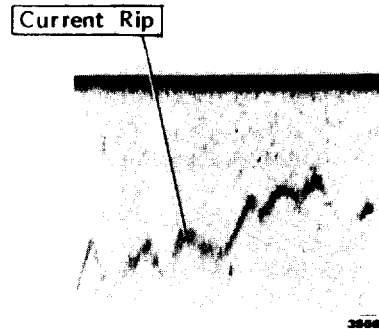

**Seabed Condition**

It is well known that abundant information useful for fishing is obtained from seabed trace on the echogram. For example, rock piles and wrecks are the places where fish gather.

**Seabed Condition**

**Profile**

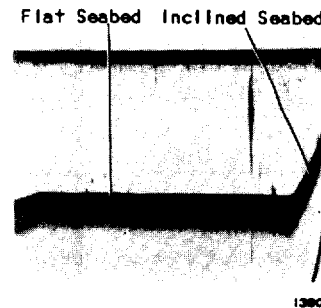

(Seabed Profile)

- \* Flat seabed with uniform nature --- Recorded as a trace of constant width.
- \* Inclined seabed/Slope of rock piles --- Recorded as a trace with long trail because ultrasonic wave is reflected in different depths.

Note: The trail becomes longer but since the seabed is inclined, apparent width of the seabed trace is narrower.

- \* Rough Seabed --- Since echo returns from various directions, they overlap each other and leaves perspective trace.

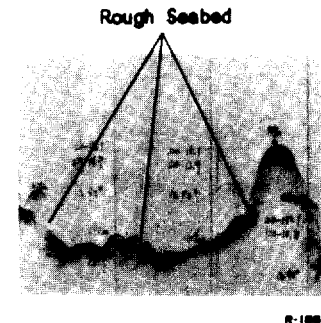

## (Nature of Seabed)

- \* Hard } Dense trace with long trail
- \* Craggy } Dense trace with long trail
- \* Mud, sand, alga — Faint trace with short trail

\* Bottom of sediment may give a long tail if a low sounding frequency is used.

For bottom discrimination, wide beamwidth (low frequency) and long pulse length are suitable. Further, since the discrimination is done by relative comparison of traces, the gain setting should be kept unchanged.

### Nature

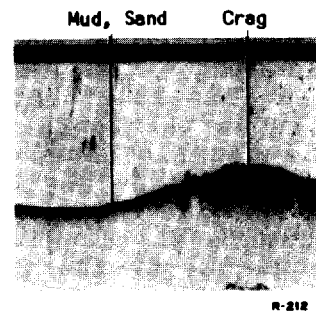

## Multiple Reflection

In a comparatively shallow water with hard seabed, the second or further multiple seabed traces are recorded. These are caused by multiple reflections of the sounding pulses at the seabed and sea surface; the echoes coming back from the seabed are reflected by the sea surface and go down again to the seabed and then return.

The true depth of water is the interval from zero line to the first seabed trace.

The multiple reflection is useable for rough check of transmission power and amplifier sensitivity.

### Multiple Reflection

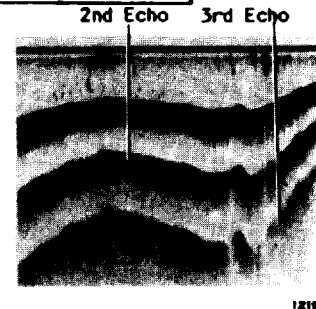

## Sea Surface Noise

Sea surface noise is plotted near the transmission line when the sea is rough or when crossing over the wake. The cause of noise is mainly air bubbles.

Proper setting of the TVG control serves to minimize the sea surface noise, allowing distinct echogram.

### Sea Surface Noise

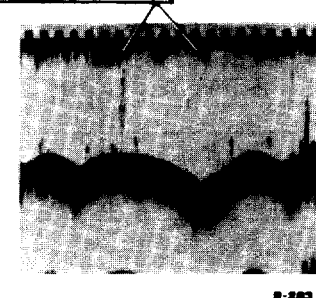

**Interruption of Recording by Air Bubbles**

In a rough sea, there is a case that the echogram is occasionally interrupted due to thick air bubbles just below the transducer, blocking the sounding path. This blanks out the recording except the zero line. It also occurs by the wake when the ship makes quick turn or backward movement.

It is quite difficult to eliminate the interruption, especially in low sounding frequency.  
 Reconsideration on installation site of the transducer is needed if the interruption occurs frequently.

Interruption of Recording by Air Bubbles

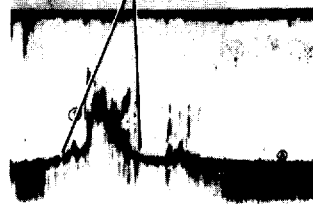

R-104

**Zig-zag Seabed Trace**

The seabed is recorded zig-zag like the teeth of a saw in a rough sea. This is caused by rolling or pitching of the ship, thereby the sounding direction fluctuates and distance to the seabed varies.

Zig-zagged Bottom Trace



R-01

**False Seabed Trace**

In the seabed with sharp gradient or high unduration, blurred trace will sometimes appear above the seabed contour, while in flat seabed, it is recorded below the contour. They are false echoes caused by side-lobe of ultrasonic beam.

So far, it is explained that ultrasonic wave is radiated only in the vertical direction as a beam (main-lobe), but in practice, there are some beams outside the main beam that are called "side-lobe". Energy of the side-lobe is fairly weak but it still can provide trace if the reflection is strong.

False Seabed Trace

Undulated Seabed



307B

Flat Seabed



Side-lobe

1944

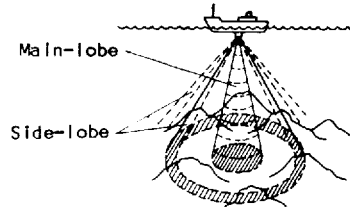

## Interference/Noise

There is a case where the echogram is disturbed by interference which appears occasionally or periodically. This is usually caused by such noises as induction from other electronic equipments on board, engine noise, ship's vibrations and interference from an echosounder of other boats operating in the vicinity in the same frequency band.

The built in Noise Limiter cancels out the random noise by comparing the echoes of last and present soundings.

### Interference/ Noise

Interference  
from motor,  
generator, etc.



Interference  
from other echo-  
sounder on own  
ship.



Interference  
from echosounder  
on other boat



## MAINTENANCE

\* \* \* \* \*

### 1. Stylus Replacement and Adjustment

Poor or intermittent recording is caused mainly by wear of the stylus nib or collector brush. Check their condition from time to time, and readjust or replace them if necessary.

1. Turn the FUNCTION switch to " O " (off) position.
2. Release the clasp at the top of the recorder and swing down the cabinet door. Release the string hooked on the cabinet door to allow it to open fully.
3. If only the stylus nib is worn, pull it out from the sleeve, using a pair of tweezers or long-nosed pliers, until it is approx. 8mm long.

Too long a nib may cause erratic recordings due to bouncing on the paper.

4. If the collector brush is worn, remove the whole stylus assembly from the recording belt by pressing the holding tang (see drawing), and replace it with new one.
5. Reconnect the retaining string and refasten the clasp.
6. To smooth the end of the stylus nib, place a piece of sandpaper (supplied) over the recording paper and turn the power on for several belt revolutions, being careful to keep your fingers away from the moving stylus.
7. If necessary, readjust the setting position of the scale plate to place its zero point at the transmission line. (Make sure that the Draft control is turned fully counterclockwise!)

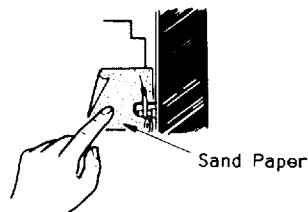
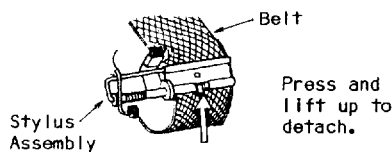
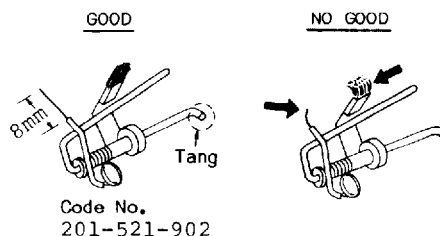
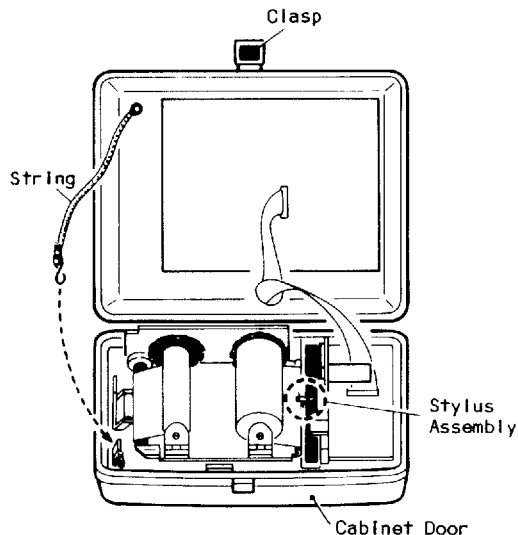



## 2. Fuse Replacement

A 3A fuse is provided inside the recorder. It may be blown by improper mains voltage/polarity, mechanical overloading or by accidental shortcircuit. If it is blown, first find out the cause of the trouble, and then replace the fuse. Never use a larger fuse to avoid serious damage to the circuitry. When replacing the fuse, disconnect the power plug at the back to avoid accidental short-circuiting.

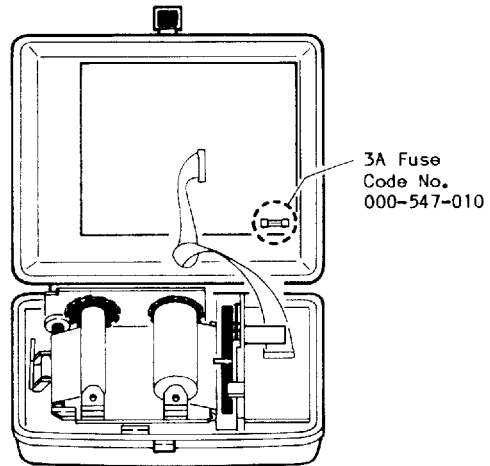

## 3. Cleaning

**CAUTION**

Keep recorder clean using a clean moistened cloth rag. Put vinyl cover on when it is not used.

Do not use plastic solvent or active chemicals for cleaning.

---

**Dry recording paper inherently creates power dust. Clean the recorder interior using the brush supplied.**

---

**Keep transducer face clean.**

Oysters or seaweed on the transducer face will result in degraded detecting performance. Gently remove them when drydocked. Do not paint on the face.

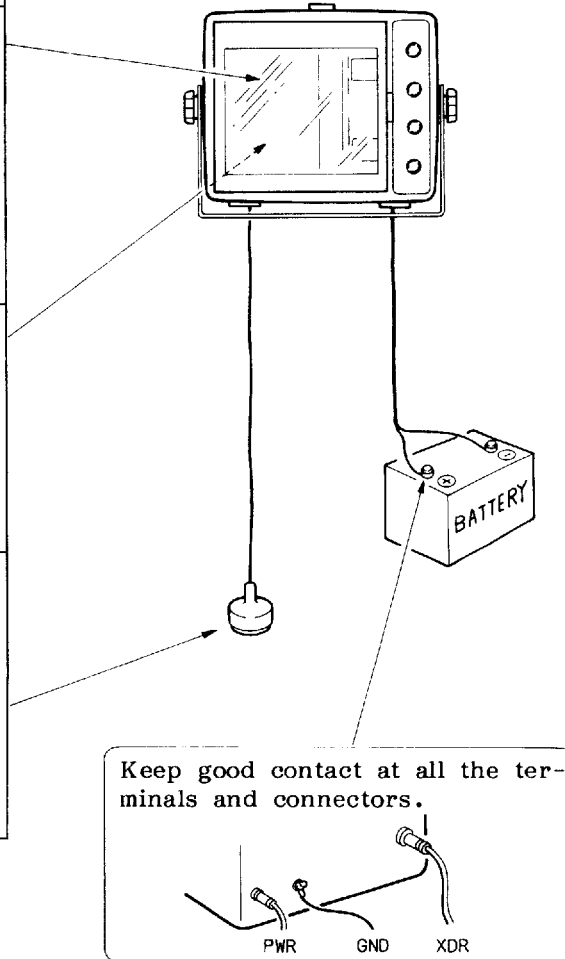

## TROUBLESHOOTING

\* \* \* \* \*

The following table shows simple troubleshooting that can be done by the operator himself. Problems not covered here are best referred to a qualified electronics technician.

Symptom	Possible Cause	Remedy
Not working at all	<ol style="list-style-type: none"> <li>1. Switch at main switch board is turned off.</li> <li>2. Power connector is loose or out.</li> <li>3. Too low input voltage (Battery is flat.)</li> <li>4. Fuse on transceiver board is blown.</li> </ol>	<ol style="list-style-type: none"> <li>1. Turn on the main switch.</li> <li>2. Secure connector firmly.</li> <li>3. Check mains voltage is within 11 to 40VDC.</li> <li>4. If blown, check mains voltage first, and then replace 3A fuse.</li> </ol>
Lamp/LED lit, but motor is not rotating.	<ol style="list-style-type: none"> <li>1. Poor connection inside</li> </ol>	<ol style="list-style-type: none"> <li>1. Check that connectors on the boards are firmly plugged in.</li> </ol>
Motor rotating, but no recording	<ol style="list-style-type: none"> <li>1. Stylus nib or collector brush is worn.</li> <li>2. Poor connection inside</li> <li>3. DRAFT control is set too deep while using shallow ranges.</li> </ol>	<ol style="list-style-type: none"> <li>1. Readjust or replace it.</li> <li>2. Check that connectors on the boards are firmly plugged in.</li> <li>3. Readjust DRAFT control.</li> </ol>
Zero line but no echo trace	<ol style="list-style-type: none"> <li>1. GAIN control is set too low.</li> <li>2. Transducer connector is loose or out.</li> <li>3. Transducer is not in contact with water.</li> </ol>	<ol style="list-style-type: none"> <li>1. Increase the GAIN.</li> <li>2. Secure connector firmly.</li> <li>3. Put transducer in water.</li> </ol>
Recording is faint and dim.	<ol style="list-style-type: none"> <li>1. Stylus nib is formed improperly.</li> <li>2. Thick dirt on front window</li> </ol>	<ol style="list-style-type: none"> <li>1. Readjust stylus nib.</li> <li>2. Clean up window.</li> </ol>
Recording is too dark and heavy.	<ol style="list-style-type: none"> <li>1. Gain is set too high.</li> <li>2. Stylus is bent to tear paper.</li> </ol>	<ol style="list-style-type: none"> <li>1. Decrease the GAIN.</li> <li>2. Readjust stylus nib.</li> </ol>
Uneven intensity in recording	<ol style="list-style-type: none"> <li>1. Stain on collector rail</li> </ol>	<ol style="list-style-type: none"> <li>1. Polish up rail.</li> </ol>

Symptom	Possible Cause	Remedy
Irregular paper advance	<ol style="list-style-type: none"><li>1. Recorder assembly is not fully snapped in. (Pinch roller not engaged)</li><li>2. Reduction gear of take-up motor jammed.</li></ol>	<ol style="list-style-type: none"><li>1. Push in the recorder assembly.</li><li>2. Remove paper dust on the gears.</li></ol>
Chart recording OK but digital display abnormal (unreadable)	<ol style="list-style-type: none"><li>1. Loose connection inside</li></ol>	<ol style="list-style-type: none"><li>1. Check plug connections on the boards.</li></ol>
Seabed depth reading is incorrect or unstable.	<ol style="list-style-type: none"><li>1. SHADOW LINE control is not adjusted for seabed.</li><li>2. Strong interference or dense fish school exist.</li><li>3. Seabed is out of recording range.</li></ol>	<ol style="list-style-type: none"><li>1,2. Readjust GAIN and/or SHADOW LINE control.</li><li>3. Select a depth range to see seabed echo.</li></ol>

## SPECIFICATIONS OF FE-606 ECHOSOUNDER

\*\*\*\*\*

### 1. DEPTH RANGE, SOUNDING RATE & PULSELENGTH:

RANGE		FE-606M (meter)	FE-606FT (foot)	FE-606FA/PA (fathom,passi)	SOUNDING RATE(/min)	PULSELENGTH (msec)	
N O R M A L	1	a	0- 10	0- 30	0- 5.0	172	0.4
		b	5- 15	15- 45	2.5- 7.5		
	2	a	0- 20	0- 60	0- 10		
		b	10- 30	30- 90	5- 15		
	3	a	0- 40	0- 120	0- 20		
		b	20- 60	60- 180	10- 30		
	4	a	0-100	0- 300	0- 50	86	1.0
		b	50-150	150- 450	25- 75		
	5	a	0-200	0- 600	0- 100	86	2.0
		b	100-300	300- 900	50- 150		
	6	a	0-400	0-1200	0- 200	57	2.0
		b	200-600	600-1800	100- 300		
BOTTOM LOCK		5.0	15	2.5			

2. RECORDING SYSTEM: Straight line recording
3. PRESENTATION MODE: a) Normal(full paper width)  
b) Normal(upper 2/3) plus Bottom Lock(lower 1/3)
4. RECORDING PAPER: Dry electrosensitive paper  
Type; PD-1520NW (150mmx20m)
5. PAPER SPEED: 3, 6 or 10mm/min
6. INTENSITY GRADATION: Light-gray, gray and black
7. FREQUENCY & TRANSDUCER: 50kHz: 50B-6  
200kHz: 200B-5S
8. OUTPUT POWER: 300W nominal
9. CONTROLS: Front Panel: a) Range b) Gain  
c) Shadow Line  
d) Function (OFF/ON/BL)  
Internal: a) Noise Limiter  
b) Paper Speed  
c) TVG (Time Varied Gain)  
d) Draft (zero line shift)  
e) Power Reduction
10. DIGITAL READOUT: a) Start depth and end depth  
[Shadow Line OFF]  
b) Start depth and seabed depth  
[Shadow Line ON]
11. POWER SUPPLY: 11 to 40VDC universal, 20W approx.

[ EQUIPMENT LIST ]

No.	Name	Type	Q'ty	Remarks
1	Recorder Unit	FE-606	1	
2	Transducer		1	
3	Installation Materials		1 set	See separate list.
4	Spare Parts		1 set	See separate list.

[ STANDARD SPARE PARTS ]

No.	Name	Type	Code No.	Q'ty	Remarks
1	Fuse	FGEO-A, 3A, AC125V	000-549-063	1	
2	Recording Stylus	02-015-2190-2	201-521-902	1	
3	Sand Paper	#240 90x90mm	000-835-008	1	
4	Recording Paper	PD-1520NW	000-878-455	1	
5	Brush		000-831-516	1	
6	Paper Spool	FDX-2112	211-921-122	2	

[ INSTALLATION MATERIALS ]

No.	Name	Type	Code No.	Q'ty	Remarks
1	4P Connector	NCS-254P	000-506-505	1	for XDR connection
2	Power Cable	VCTFK0.75X2C	002-475-800	3.5m	with 2P plug
3	Hanger Bracket	02-019-0002	002-475-810	1	
4	Knob Bolt	KG-B2 M8x20mm	000-861-934	2	
5	Gasket (1)	02-019-0003	201-900-031	2	ø30
6	Gasket (2)	02-019-0005	201-900-050	2	ø25

[ TRANSDUCER/TANK/THRU-HULL PIPE ]

FREQUENCY	TRANSDUCER	TANK	THRU-HULL PIPE	USE	
50kHz	50B-6 (000-015-042)	T-605 (000-015-515)	TFB-5000 (000-015-206)	Steel Hull	
		T-605-W (000-015-517)	TFB-1000 (000-015-201)	Wooden Hull	
		T-605-F (000-015-516)	TRB-1000 (000-015-215)	Plastic Hull	
	50B-6G (000-015-016)	T-27 (000-015-313)	—	—	Sideboard
		T-27A (000-015-558)	—	—	—
		50B-5NR (000-015-014)	—	—	Wooden Hull (Direct Mount)
200kHz	200B-5S (000-015-029)	T-605 (000-015-515)	TFB-5000 (000-015-206)	Steel Hull	
		T-605-W (000-015-517)	TFB-1000 (000-015-201)	Wooden Hull	
		T-605-F (000-015-516)	TRB-1000 (000-015-215)	Plastic Hull	
	200B-5NR (000-015-028)	T-27 (000-015-313)	—	—	Sideboard
		—	—	—	—
		—	—	—	Wooden Hull (Direct Mount)

## INSTALLATION

\* \* \* \* \*

### 1. Selection of Installation Site

#### Transducer

The performance of the echosounder depends greatly upon the transducer position. The following points should be taken into account:

- \* Select a place not effected by air bubbles.

It is known that bubbles are at minimum at the place where the first bow wave falls and the next wave rises at general cruising speed. In small boats with slow speed, midship position is usually a good place. In high speed boats, select a place where the transducer is always in contact with the water.

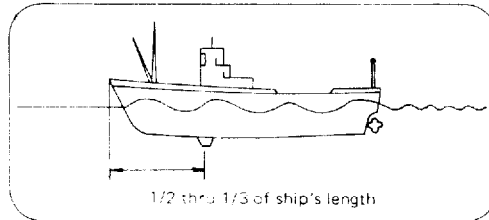

- \* If it is possible, put the transducer flush on the keel line.
- \* To further reduce the effect of air bubbles, it is recommended to project the transducer by approx. 250mm from the hull plate, but not below the keel level.
- \* The face of the transducer must be facing the sea bottom in normal cruising trim of the vessel.
- \* Select a place as far from engine, generator, motor or other electric equipments.

A fairing block will be necessary both to prevent turbulence related problems and to protect the transducer from damage due to debris in the water. The fairing block should be fabricated locally by a shipyard skilled in such specialized work.

The transducer can also be installed on the sideboard using pipe and clamps, but note that the boat has to be small in size and slow of speed due to limited strength of the transducer pipe.

#### Recorder Unit

The recorder unit can be installed in any convenient place in the steering bridge. To expect extended performance, however, the following points should also be taken into consideration:

- \* Select a well ventilated place not exposed to direct sunbeam and water splash.
- \* Select a place sufficiently far apart from noise generating equipment, radio equipment and antenna feeders.
- \* Select a place convenient for operation, observation, maintenance and future service.

## 2. Mounting

### Transducer

Refer to the drawings on pages AP2-3 and AP2-4 for typical transducer installations.

### Recorder Unit

The recorder unit can be mounted on table-top, ceiling or bulkhead. Using appropriate bolts or woodscrews, fix the mounting bracket in the planned position. As necessary, reinforce the mounting location by doubling plate or lining blocks.

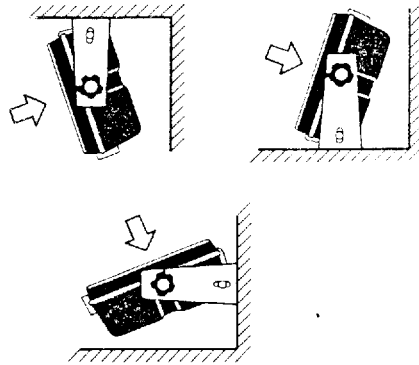

Mount the recorder unit into the mounting bracket and fasten the knob screws considering the best viewing angle. As necessary, adjust the positions of bottom rubber pads to minimize vibration.

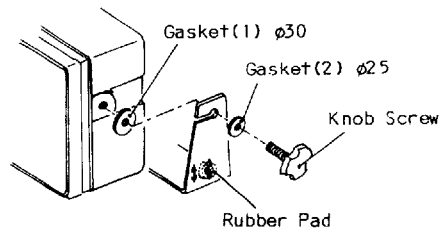

## 3. Cable Connections

Three cables are connected to the recorder unit: power cable, transducer cable and grounding wire. (Refer to page AP2-5 for connection diagram.)

### Power Cable

The recorder side of the power cable is factory-wired with a 2P plug. Connect the other side of the cable to the battery or to a rectifier. (white: positive, black: negative)

### Transducer Cable

Run the transducer cable to the recorder and connect the 4P plug (supplied) to the end of the cable. If optional transducer (50B-5NR/200B-5NR) is used, cut off the 3P plug on its cable end and put the 4P one instead.

### Grounding Wire

The recorder unit is provided with the grounding terminal on its back. Using wire of around 5mm<sup>2</sup>, connect it to the recorder terminal and to ship's main ground.

EXAMPLES OF TRANSDUCER INSTALLATION

[ HULL BOTTOM MOUNT ]

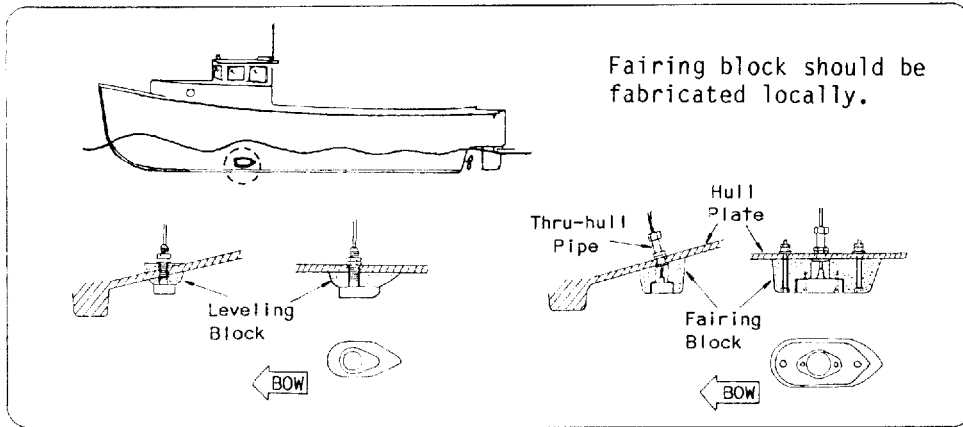

[ SIDEBORD MOUNT ]

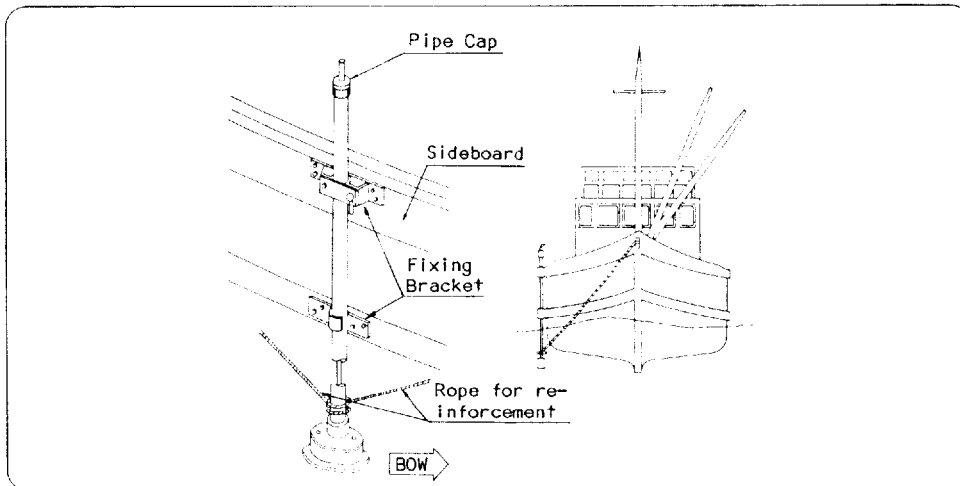

[ TRANSOM MOUNT ]

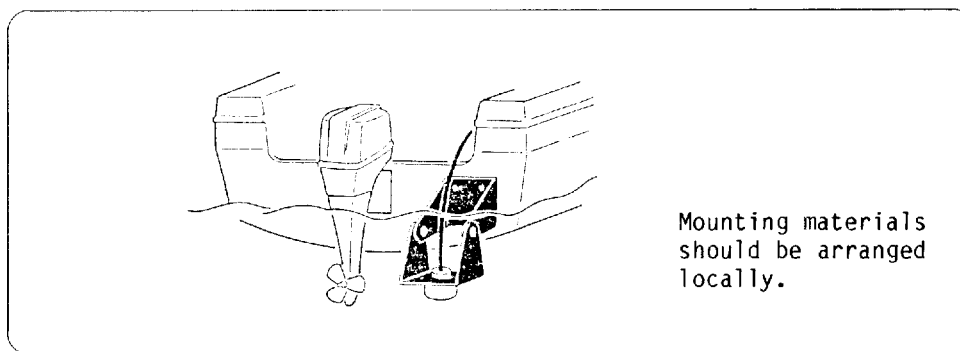



## [ TRANSDUCER TANK ]

### STEEL HULL

T-605

TRANSDUCER: 50B-6(6B),  
200B-5S

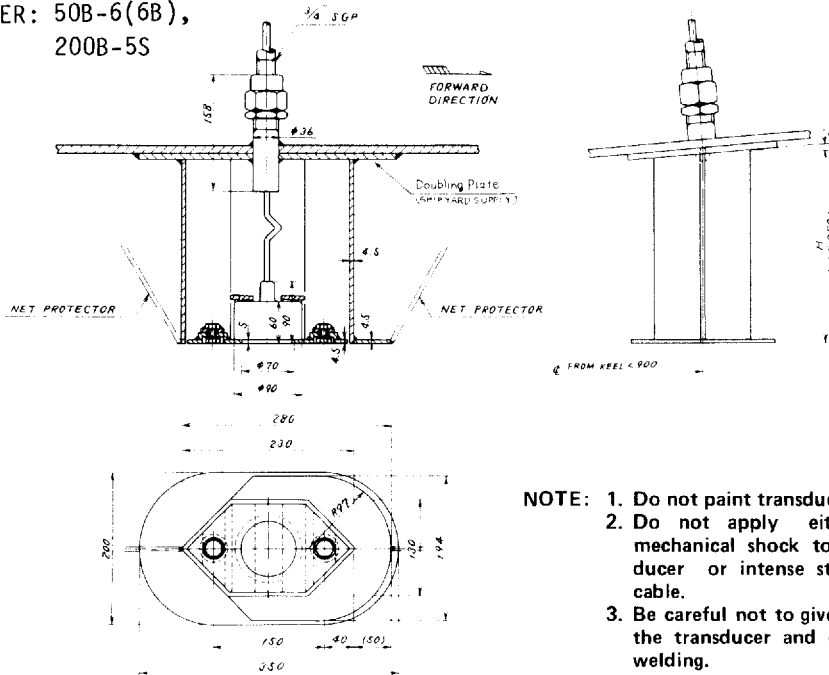

- NOTE: 1. Do not paint transducer face.  
2. Do not apply either strong mechanical shock to the transducer or intense stress to the cable.  
3. Be careful not to give damage to the transducer and cable while welding.

### WOODEN HULL

T-605-W

TRANSDUCER: 50B-6(6B), 200B-5S

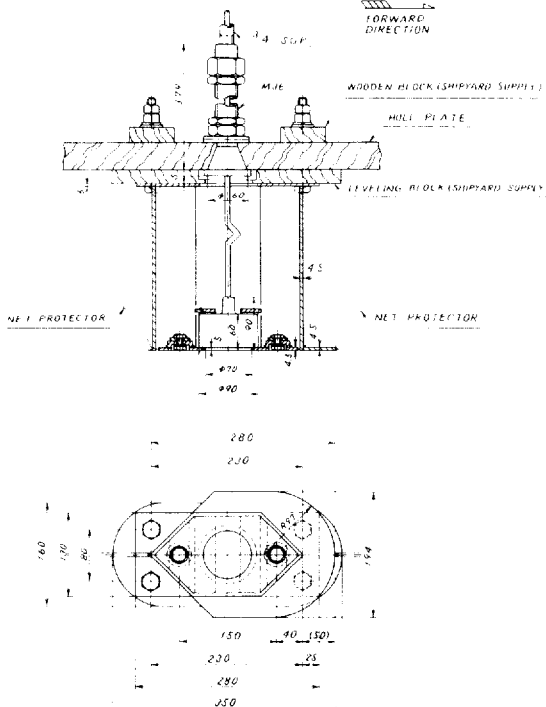

### PLASTIC HULL

T-605-F

TRANSDUCER: 50B-6(6B), 200B-5S

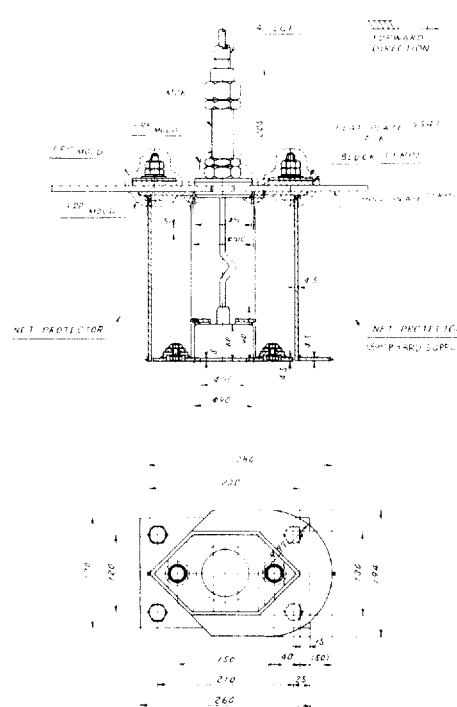

A  
B  
C  
D



2C SHIELDED  
CABTYRE CABLE  
2芯シールド  
キャブタイヤケーブル  
10m, φ12

2C VINYL SHEATHED CABLE  
2芯ビニール線  
02S4108  
(VVSB 0.75X2C, 3.5m)

SHIP'S MAINS  
船内電源

11 - 40VDC  
(UNIVERSAL)

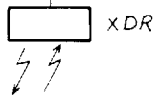

TRANSDUCER PLUG  
送受波器プラグ

POWER PLUG  
電源プラグ

SOLDERING SIDE  
半田面

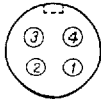

- ① N.C.
- ② CONDUCTOR 芯線
- ③ SHIELD シールド
- ④ CONDUCTOR 芯線

- ① BLK クロ (-)
- ② WHT シロ (+)

承認 APPROVED	品番 ITEM	品名 NAME	材質 MATERIAL	数量 QTY	図番 DWG. NO.	摘要 REMARKS
NOV. 26. 82 <i>[Signature]</i>		三角法 THIRD ANGLE PROJECTION				
検査 CHECKED	NOV. 26. 82 <i>[Signature]</i>	尺度 SCALE				名称 TITLE FE-606 CONNECTION DIAGRAM 結線図
製 DRAWN	NOV. 24. 82 <i>[Signature]</i>	重量 WEIGHT	kg			番 DWG. NO. C2279-005-B

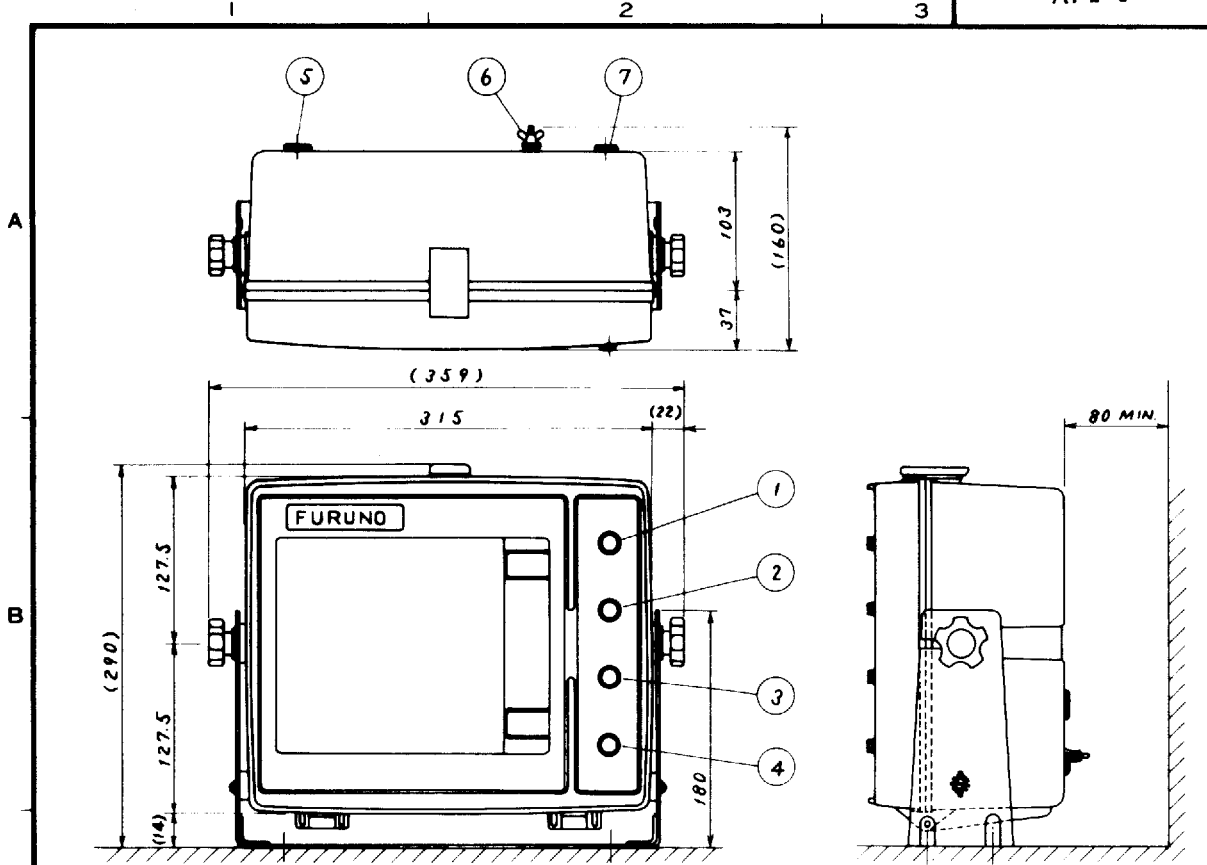

ハンガー取付寸法  
MOUNTING DIMENSION

取付穴  
4-φ7 FIXING HOLE

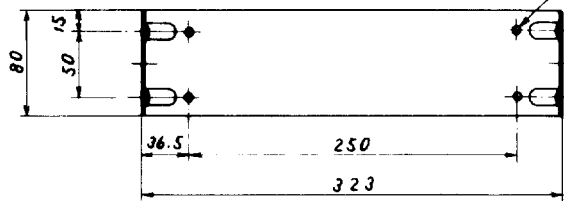

コンパス安全距離  
COMPASS SAFE DISTANCE

スタンダード STANDARD	1.0M
ステアリング STEERING	0.75M

7	電源コネクタ POWER CONNECTOR		1		
6	アース端子 EARTH TERMINAL		1		
5	速度波器コネクタ XDR CONNECTOR		1		
4	電源・表示切換スイッチ FUNCTION SWITCH		1		
3	感度つまみ GAIN CONTROL		1		
2	海底判別つまみ SHADOW LINE CONTROL		1		
1	深度範囲スイッチ RANGE SWITCH		1		
品番 ITEM	品名 NAME	材質 MATERIAL	数量 QTY	図番 DWG. NO.	摘要 REMARKS

承認 APPROVED	NOV. 29 '82 <i>[Signature]</i>	三角法 THIRD ANGLE PROJECTION	名称 TITLE	RECORDER UNIT
検 CHECKED	NOV. 29 '82 <i>[Signature]</i>	尺度 SCALE	FE-606 616	記録器外觀図
製 DRAWN	NOV. 29 '82 <i>[Signature]</i>	重量 WEIGHT	5 kg	図番 DWG. NO. C2279-004-C

## HOW TO CHANGE CALIBRATION UNIT

\*\*\*\*\*

The FE-606 can provide depth readout in one of four units; meters, feet, fathoms or brazas/passis.

If necessary, change calibration unit following the procedure below. Note that the alteration involves three jumper plugs and one trim pot.

### [ Procedure ]

1. Change the positions of three jumper plugs depending on your desired calibration unit. See right figure and table below.

2. Operate the recorder with the front panel controls set as follows.

RANGE: Max. ("6b")  
 SHADOW LINE: Off ("○")  
 FUNCTION: Normal ("■")

3. Adjust trim pot R7 on the display board so that the lower readout shows the exact end depth of the range.

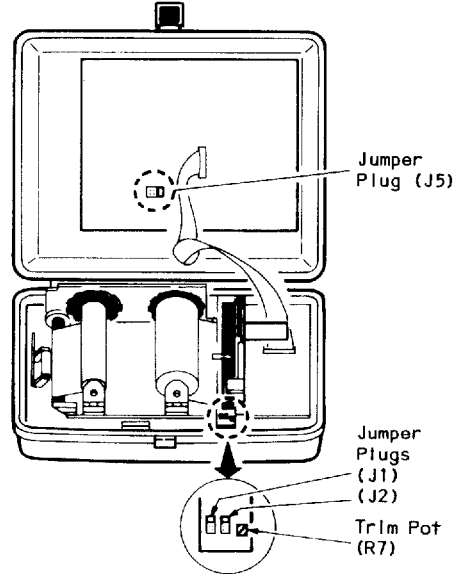

Unit	Lower Reading (End Depth)
Meters	6 0 0
Feet	8.0 0 (1 8 0 0)
Fathoms Brazas Passis	3 0 0

Unit	Jumper Plugs		
	J5	J1	J2
Meters			
Feet			
Fathoms			
Brazas Passis			

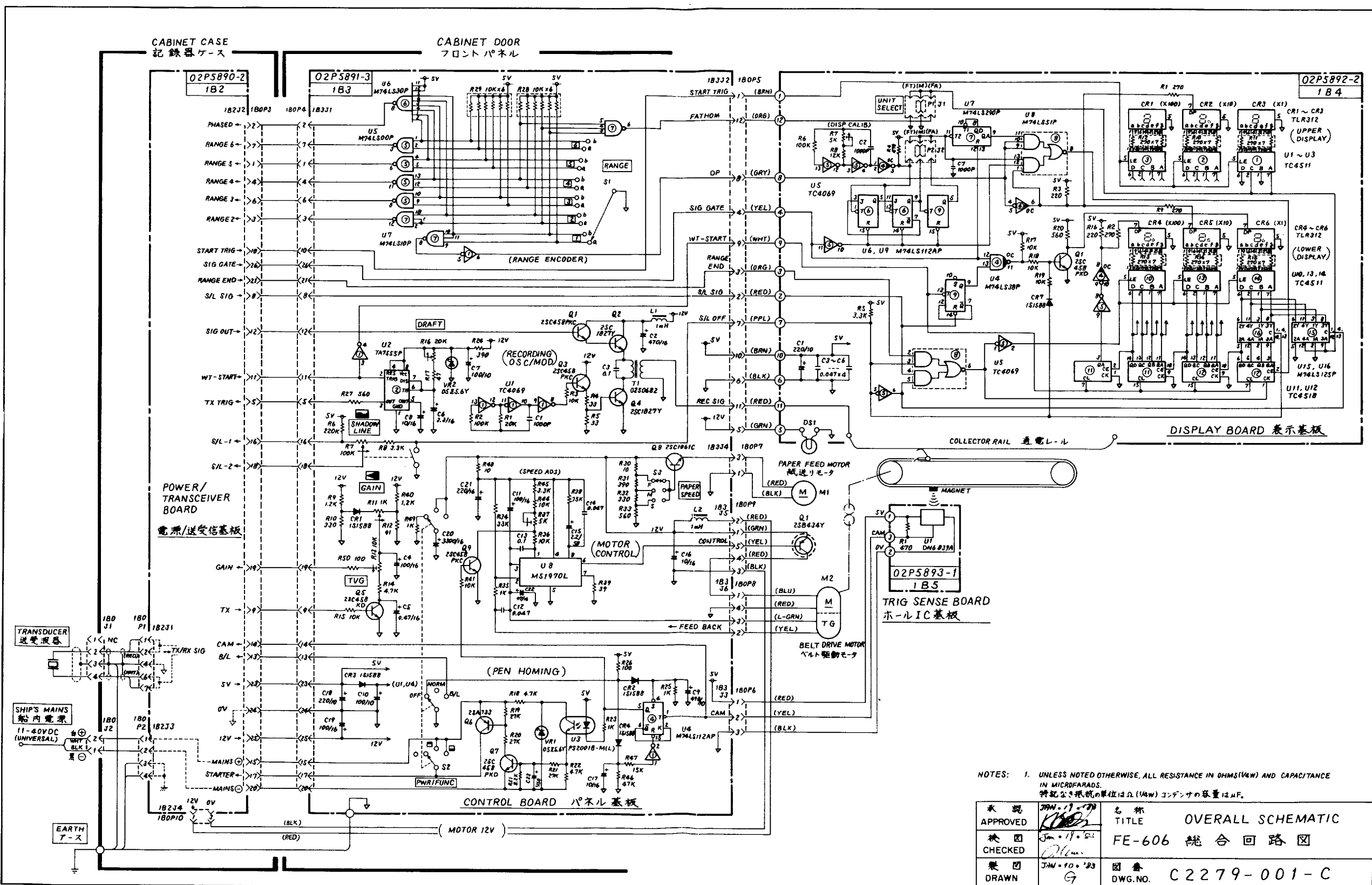

NOTES: 1. UNLESS NOTED OTHERWISE, ALL RESISTANCE IN OHMS(Ω) AND CAPACITANCE IN MICROFARADS.  
 特記なき抵抗の単位はΩ(Ω) コンデンサの容量はμF.

承認 APPROVED	JMW-10-23 <i>[Signature]</i>	名称 TITLE	OVERALL SCHEMATIC
検回 CHECKED	JMW-10-23 <i>[Signature]</i>	図番 DWG. NO.	FE-606 総合回路図
製図 DRAWN	JMW-10-23 G		C2279-001-C

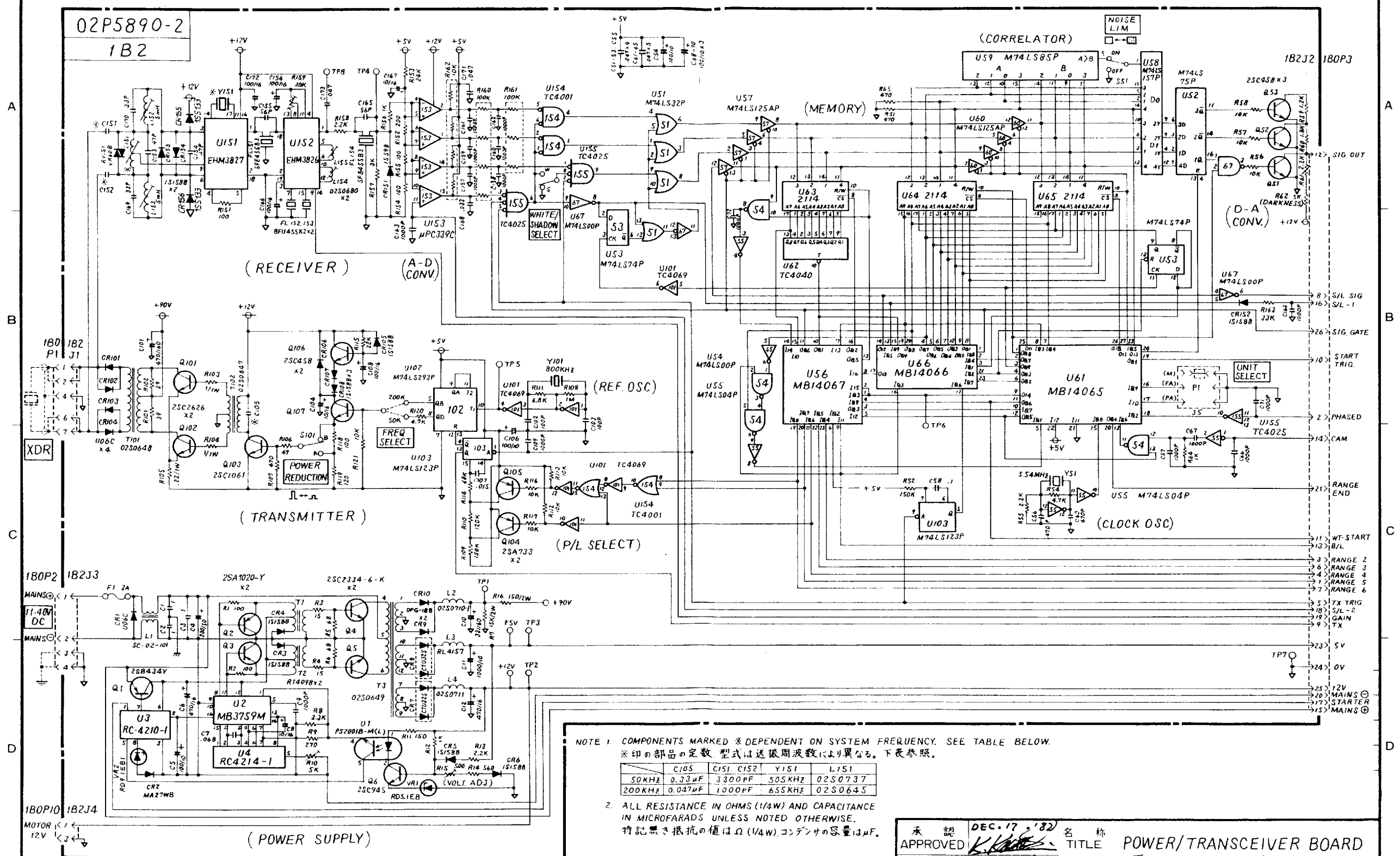

NOTE 1. COMPONENTS MARKED \* DEPENDENT ON SYSTEM FREQUENCY. SEE TABLE BELOW.  
\*印の部品の定数、型式は送振周波数により異なる。下表参照。

	C105	C151	C152	Y151	L151
50KHZ	0.33 $\mu$ F	3300PF	505KHZ	02S0737	
200KHZ	0.047 $\mu$ F	1000PF	655KHZ	02S0645	

NOTE 2. ALL RESISTANCE IN OHMS (1/4W) AND CAPACITANCE IN MICROFARADS UNLESS NOTED OTHERWISE.  
特記なき抵抗の値は $\Omega$  (1/4W)、コンデンサの容量は $\mu$ F.

承認 APPROVED	DEC. 17 '82	名称 TITLE	POWER/TRANSCIVER BOARD
検 CHECKED			FE-606 電源/送受信基板
製 DRAWN		番 DWG. NO.	C2279-002-D