

FURUNO

OPERATOR'S MANUAL

SATELLITE COMPASS

Model

SC-50

ECF

(Elemental Chlorine Free)

The paper used in this manual
is elemental chlorine free.

FURUNO ELECTRIC CO., LTD.

9-52 Ashihara-cho,
Nishinomiya, 662-8580, JAPAN

• FURUNO Authorized Distributor/Dealer

All rights reserved. Printed in Japan

Pub. No. OME-72510-G2

(ETMI) SC-50

A : FEB. 2004

G2 : DEC. 19, 2017



0 0 0 1 4 8 5 4 8 1 6

IMPORTANT NOTICES

General

- The operator of this equipment must read and follow the descriptions in this manual. Wrong operation or maintenance can cancel the warranty or cause injury.
- Do not copy any part of this manual without written permission from FURUNO.
- If this manual is lost or worn, contact your dealer about replacement.
- The contents of this manual and equipment specifications can change without notice.
- The example screens (or illustrations) shown in this manual can be different from the screens you see on your display. The screens you see depend on your system configuration and equipment settings.
- Save this manual for future reference.
- Any modification of the equipment (including software) by persons not authorized by FURUNO will cancel the warranty.
- All brand and product names are trademarks, registered trademarks or service marks of their respective holders.

How to discard this product

Discard this product according to local regulations for the disposal of industrial waste. For disposal in the USA, see the homepage of the Electronics Industries Alliance (<http://www.eiae.org/>) for the correct method of disposal.

How to discard a used battery

Some FURUNO products have a battery(ies). To see if your product has a battery, see the chapter on Maintenance. Follow the instructions below if a battery is used. Tape the + and - terminals of battery before disposal to prevent fire, heat generation caused by short circuit.

In the European Union

The crossed-out trash can symbol indicates that all types of batteries must not be discarded in standard trash, or at a trash site. Take the used batteries to a battery collection site according to your national legislation and the Batteries Directive 2006/66/EU.

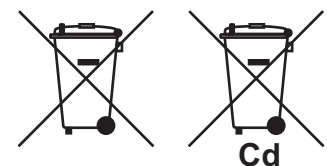

In the USA

The Mobius loop symbol (three chasing arrows) indicates that Ni-Cd and lead-acid rechargeable batteries must be recycled. Take the used batteries to a battery collection site according to local laws.

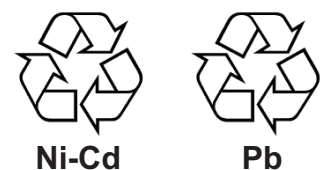



In the other countries

There are no international standards for the battery recycle symbol. The number of symbols can increase when the other countries make their own recycling symbols in the future.









SAFETY INSTRUCTIONS



The operator and installer must read the applicable safety instructions before attempting to install or operate the equipment.

 WARNING	Indicates a potentially hazardous situation which, if not avoided, could result in death or serious injury.
 CAUTION	Indicates a potentially hazardous situation which, if not avoided, can result in minor or moderate injury.



 Warning, Caution	 Prohibitive Action	 Mandatory Action
--	--	---

Safety Instructions for the Operator

 WARNING
 ELECTRICAL SHOCK HAZARD Do not open the equipment. Only qualified personnel should work inside the equipment.
 Do not disassemble or modify the equipment. Fire, electrical shock or serious injury can result.
 Immediately turn off the power at the switchboard if the equipment is emitting smoke or fire. Continued use can cause fatal damage to the equipment. Contact a FURUNO agent for service.
 Do not place liquid-filled containers on the top of the processor unit. Fire or electrical shock may result if the liquid enters the equipment.
 Use the proper fuse. Use of a wrong fuse can damage the equipment and cause fire.

 CAUTION
 No one navigation device should ever be solely relied upon for the navigation of a vessel. Always confirm position against all available aids to navigation (incl. nautical charts), for safety of vessel and crew.





Safety Instructions for the Installer

 WARNING
 Turn off the power at the switchboard before beginning the installation. Fire or electrical shock can result if the power is left on.
 Do not install the equipment where it may get wet from rain or water splash. Water in the equipment can cause fire, electrical shock or damage to the equipment.

NOTICE		
	Observe the following compass safe distances to prevent interference to a magnetic compass:	
	Standard Compass	Steering Compass
Display unit SC-502	0.4 m	0.3 m
Processor unit SC-501	0.9 m	0.55 m
Antenna unit SC-303	0.3 m	0.3 m
Antenna unit SC-603	0.3 m	0.3 m

WARNING LABEL

A warning label is attached to the processor unit. Do not remove the label. If the label is missing or damaged, contact a FURUNO agent or dealer about replacement.

 WARNING 
<small>To avoid electrical shock, do not remove cover. No user-serviceable parts inside.</small>
 

WARNING LABEL

Name: Warning Label (1)
Type: 86-003-1011-1
Code No.: 100-236-231

TABLE OF CONTENTS

FOREWORD.....	v
SYSTEM CONFIGURATION	vi
EQUIPMENT LIST	vii
1 INSTALLATION	1-1
1.1 Mounting Considerations.....	1-1
1.1.1 Antenna unit.....	1-1
1.1.2 Display unit, processor unit.....	1-3
1.2 Installing the Antenna Unit.....	1-4
1.2.1 Antenna unit SC-303	1-4
1.2.2 Antenna unit SC-603	1-7
1.3 Installing the Processor Unit.....	1-12
1.3.1 Bulkhead mount.....	1-12
1.3.2 Deck mount.....	1-13
1.3.3 Installation on the underside of a desk	1-14
1.4 Installing the Display Unit.....	1-15
1.4.1 Desktop, overhead mounting.....	1-15
1.4.2 Flush mount.....	1-15
1.5 Wiring	1-17
1.6 Initial Settings	1-20
1.6.1 Confirming satellite status.....	1-20
1.6.2 Choosing mounting method.....	1-21
1.7 Connection of External Equipment.....	1-22
1.7.1 General wiring.....	1-22
1.7.2 Fabrication of cables.....	1-23
2 OPERATION	2-1
2.1 Controls	2-1
2.2 Turning the Power On/Off.....	2-2
2.3 Panel Illumination, Display Contrast.....	2-2
2.4 Choosing a Display	2-3
2.5 Alarm Setup.....	2-6
2.6 Confirming Satellite Status	2-7
2.7 GPS Setup	2-8
2.7.1 Displaying the GPS setup menu.....	2-8
2.7.2 GPS SETUP menu description.....	2-8
2.8 Output Data	2-9
2.8.1 Heading	2-9
2.8.2 Log pulse	2-13
2.9 System Setup	2-14
2.9.1 Geodetic data	2-14
2.9.2 Units of measurement.....	2-15
2.9.3 Using local time	2-15
2.9.4 Time format.....	2-15
2.9.5 Demonstration mode	2-16
2.10 WAAS/DGPS Setup	2-17
2.11 OTHERS Menu	2-19
2.12 TRIP Menu	2-20
2.13 Resetting Distance Run.....	2-21
2.14 Choosing External Heading Source for Backup.....	2-21

3 MAINTENANCE, TROUBLESHOOTING	3-1
3.1 Preventive Maintenance	3-1
3.2 Troubleshooting	3-2
3.3 Diagnostics	3-3
3.4 Program Number	3-7
3.5 Clearing Data	3-7
3.6 Replacement of Battery	3-8
3.7 Replacement of Fuse.....	3-9
3.8 Error Messages.....	3-9
APPENDIX	AP-1
1. Menu Tree	AP-1
2. Digital Interface.....	AP-2
3. Input/Output Ports.....	AP-8
4. Parts List and Parts Location	AP-10
5. Geodetic Chart Codes	AP-11
6. What is WAAS?	AP-12
7. Terminology, Units of Measurement, Symbols	AP-15
SPECIFICATIONS	SP-1
PACKING LIST	A-1
OUTLINE DRAWINGS	D-1
INTERCONNECTION DIAGRAM	S-1
INDEX.....	IN-1

FOREWORD

A Word to the Owner of the SC-50

FURUNO Electric Company thanks you for purchasing the FURUNO SC-50 THD Satellite Compass. (Hereafter, for sake of brevity, we refer to the SC-50 as Satellite Compass.) We are confident you will discover why the FURUNO name has become synonymous with quality and reliability.

Since 1948, FURUNO Electric Company has enjoyed an enviable reputation for quality and reliability throughout the world. This dedication to excellence is furthered by our extensive global network of agents and dealers.

Your satellite compass is designed and constructed to meet the rigorous demands of the marine environment. However, no machine can perform its intended function unless properly installed and maintained. Please carefully read and follow the operation, installation and maintenance procedures set forth in this manual.

We would appreciate feedback from you, the end-user, about whether we are achieving our purposes.

Thank you for considering and purchasing FURUNO.

Features

The SC-50 is a new satellite compass designed with FURUNO advanced GPS kinematic technology. This compass finds a wide range of applications for any type of ships and mobile units at sea or on land.

The main features are

- Perfect for use as heading sensor for Radar/ARPA, AIS, ECDIS, scanning sonar
- There are no mechanical parts such as gimbals or rotating motor, thus the compass is free from routine maintenance
- The performance is not affected by geomagnetism thus it is suitable for use on any vessel
- No need for speed correction like a gyrocompass
- Short settling time - three minutes
- Meets the following requirements: IMO MSC. 116(73), ISO/FDIS 22090-3, IMO A. 694(17), IEC 60945 (2002-08), IEC 61162-1 3rd Ed.2007-04.

CE declaration

With regards to CE declarations, please refer to our website (www.furuno.com), for further information about RoHS conformity declarations.

SYSTEM CONFIGURATION

The SC-50 consists of an antenna, a display unit and a processor unit. The tri-antenna system accommodates three antennas/receiver units and is available in a low-profile radome type or open type. The tri-antenna system helps reduce the influence of ship's motion (rolling).

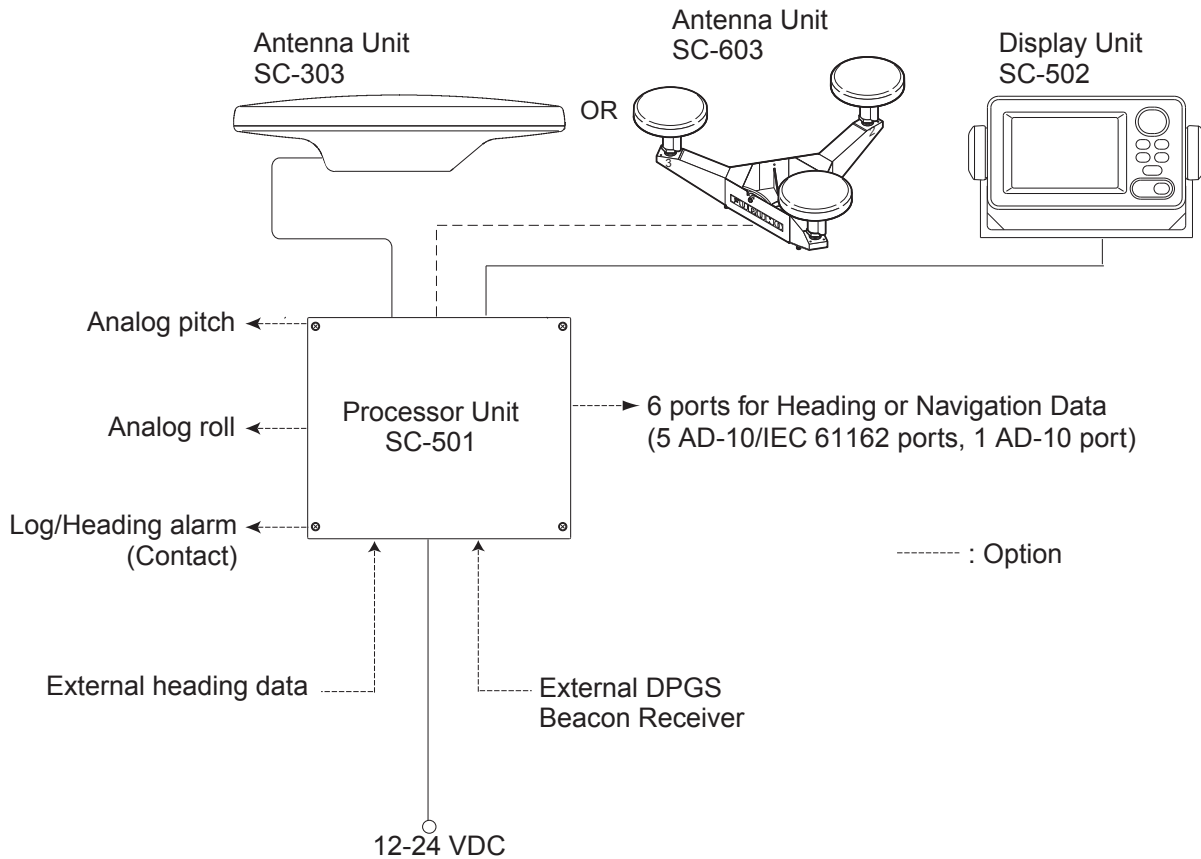

Category of Units

Processor Unit: Protected from weather
 Display Unit: Protected from weather
 Antenna Unit: Exposed to weather

System configuration

This GPS receiver complies with Canadian standard RSS-210 (Low Power License-Exempt Radio communication Devices).
 Operation is subject to the following two conditions:
 (1) this device may not cause interference, and
 (2) this device must accept any interference, including interference that may cause undesired operation of the device.

EQUIPMENT LIST

Standard supply

Name	Type	Code No.	Qty	Remarks
GPS Antenna	SC-303	—	Choose one	Radome type
	SC-603	—		Open type
Display Unit	SC-502	—	1	
Processor Unit	SC-501	—	1	
Installation Materials	CP20-02230*	004-378-110	1	TPPX cable
	CP20-02260*	004-379-660		TNC cable
	CP20-02231*	004-378-050	1	For SC-303
	CP20-02600	000-041-905	1	For processor unit: CP20-02601*, MJ-A7SPF0006-100
	CP20-02203*	004-380-660	1	For display unit: Tapping screw (5X20 4 pcs.)
	CP20-02201*	004-377-570	1	Antenna base for SC-603
	CP20-02202*	004-377-590	1	For SC-603
Spare Parts	SP20-01101*	004-379-720	1	For processor unit

Optional supply

Name	Type	Code No.	Qty	Remarks
Antenna Cable Set	CP20-01700	004-372-110	1	30 m
	CP20-01710	004-372-120		50 m
				3 sets required
Cable Assy.	TPPX6-3D2V-15M	000-143-559-10	1	Antenna cable
Flush Mount F	OP20-29*	000-041-405	1	For display unit
Flush Mount S	OP20-17*	000-040-720	1	For display unit
Bird-repellent fixture	OP20-35	004-380-820	1	For SC-303, 9 pcs.
	OP20-36	004-380-830	1	For SC-603, 4 pcs.
	OP20-37	004-380-840	1	For SC-603, 1 pc.

* See packing list at back of manual.

This page intentionally left blank.

1 INSTALLATION

1.1 Mounting Considerations

1.1.1 Antenna unit

General

- Keep the length of the antenna cable in mind when selecting a mounting location.

Installing the antenna above superstructures

- The antenna must be mounted above all other structures on the vessel to obtain an unobstructed view of the satellites regardless of vessel heading. Failure to do so will cause shadows and multipath reflection problems.

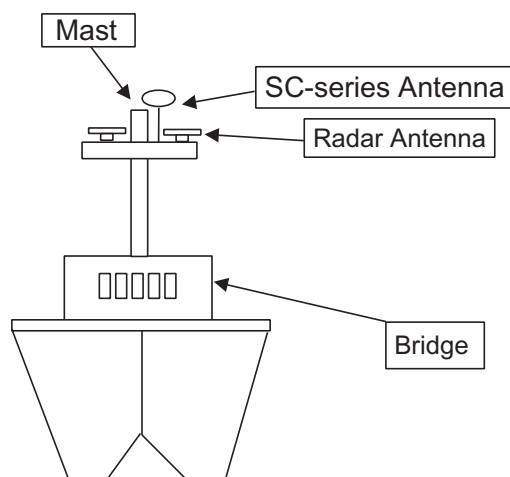

Example of antenna installed above all superstructures

Installing the antenna below superstructures

If it is not possible to mount the antenna above all superstructures on the vessel, as shown in the illustration above, shading and multipath problems may occur on at least one heading, and possibly more. To possibly avoid those problems, observe the guidelines in this section.

NOTICE

If the antenna is installed below any superstructure, the installation must be done over a two-day period, following the procedure in the service manual.

At least 12 hours are required to capture tracking data to measure multipath indexes and locate areas of shading.

1. INSTALLATION

- The horizontal separation between the antenna and masts must be as follows:

Mast diameter	Separation distance (minimum)
10 cm	1.5 m
30 cm	3 m

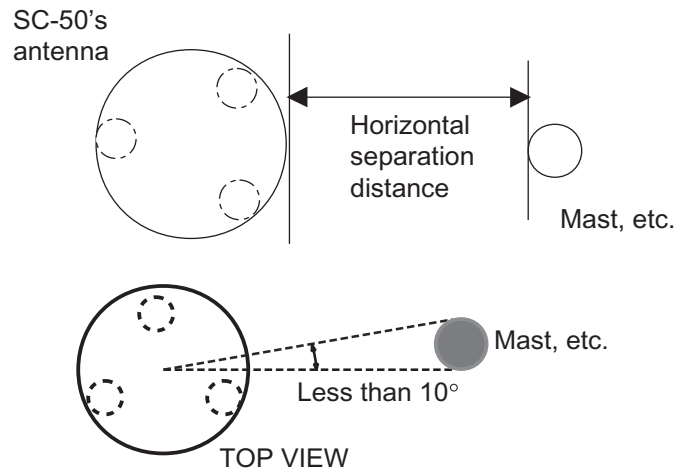

Horizontal separation between antenna and masts

- The field of view above the antenna should be as shown below, $\pm 80^\circ$ against zenith. To avoid reflections from masts and the like, locate the antenna well away from the shadows of the radar mast, etc.

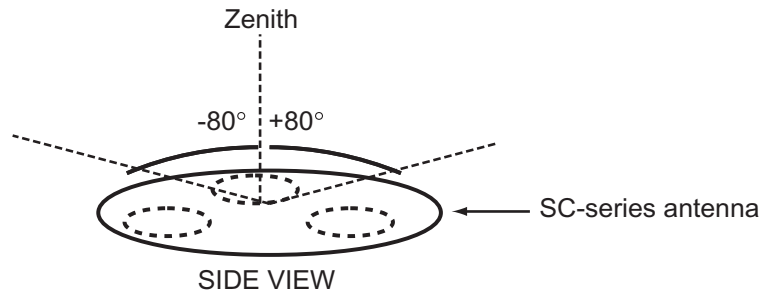

Antenna and field of view

- Locate the antenna unit above the radar antenna, out of the radar beam.

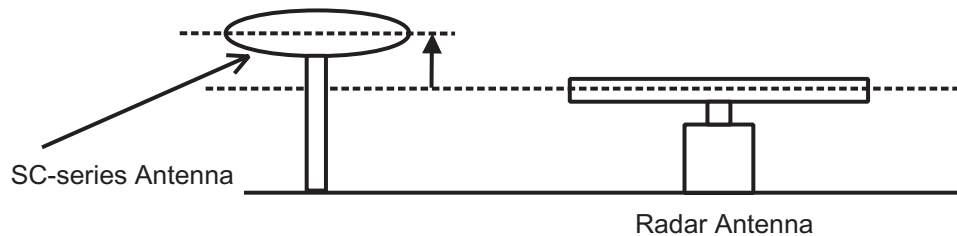

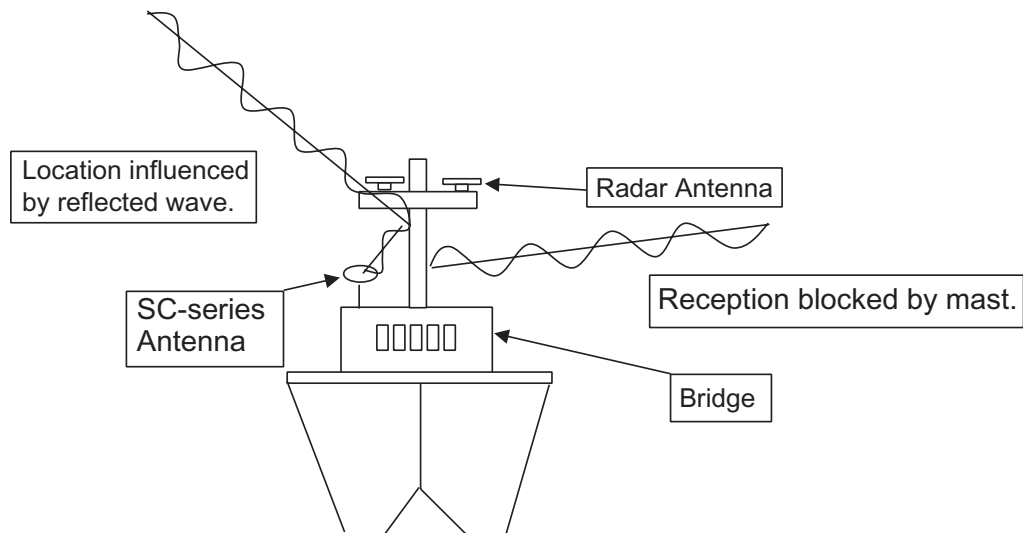

Example of antenna installed below superstructures

1.1.2 Display unit, processor unit

- Choose a location where vibration and shock are minimal.
- Install the units well away from locations subject to rain and water splash.
- Locate the units away from air conditioner vents.
- Keep the units out of direct sunlight because of heat that can build up inside their cabinets.
- Choose a well-ventilated location.
- For the display unit, choose a location where it can be easily operated.
- Leave sufficient space around the units to permit access for maintenance. See the outline drawing for recommended maintenance space.

1.2 Installing the Antenna Unit

1.2.1 Antenna unit SC-303

Note: “Bird-repellent fixtures” (supplied) may be attached to the antenna cover to prevent birds from alighting on the cover. If it is more convenient to attach them before fixing the antenna unit to the mounting location, do step 9 before fixing the antenna unit.

NOTICE

Fasten the antenna to the mounting location lastly if it is more convenient to connect the antenna cable before mounting the antenna unit.

1. Prepare a mounting platform (wood, steel or aluminum) in accordance with the illustration shown below. If corrosive material is used, take necessary anti-corrosion measures.

Note: When drilling holes in the platform, be sure they are parallel with the fore-and-aft line.

2. Orient the unit so the two lines on the base is facing the bow and then fasten the antenna unit to the platform with four sets of M10 hex. bolts, spring washers and flat washers. (The installation error should be within $\pm 2.5^\circ$.) Coat the thread of the hex. bolts with silicone grease and fasten them with the torque of 20 ± 2 Nm.

NOTICE

Do not open the antenna.

This installation does not require removal of the antenna cover.

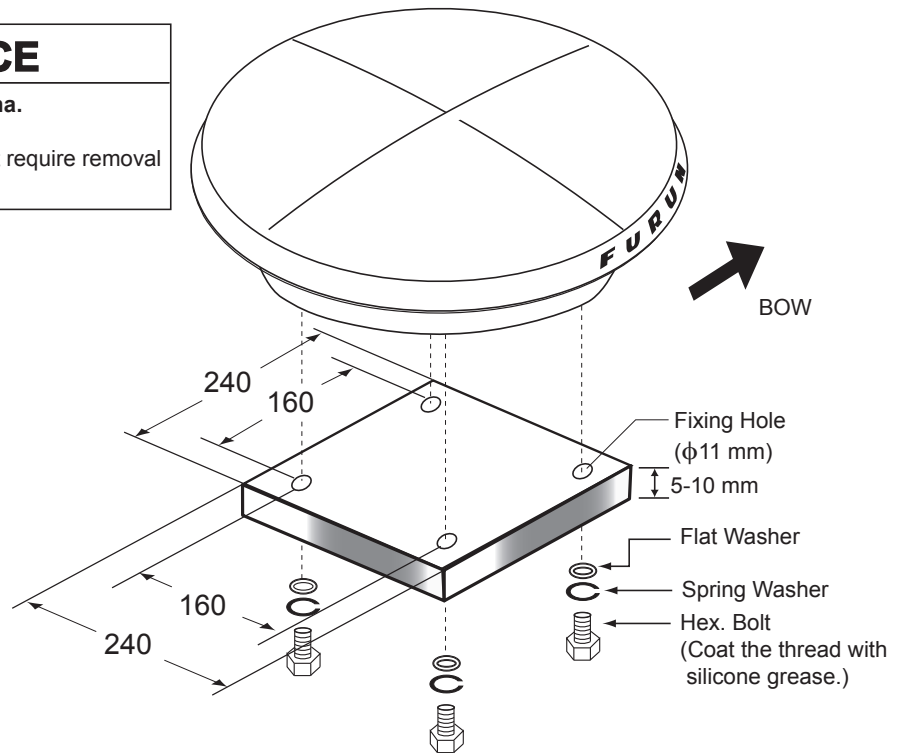

Mounting dimensions for antenna, orienting the antenna

- Coat exposed parts of nuts, bolts and washers with silicone sealant.

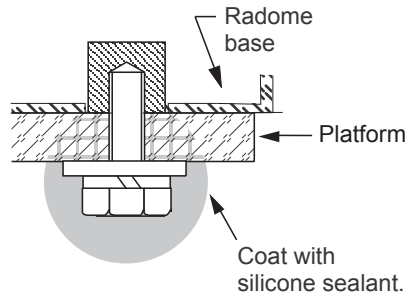

Coating bolt, nut and washers with silicone sealant

- Connect the three coaxial cables coming from the antenna unit to the appropriate coaxial cables on the antenna cable, referring to the table below.

Cable from antenna (no. marked on cable)	Cable TTPX6-3D2V-15M
ANT 1	No color
ANT 2	Yellow
ANT 3	Red

For TNC-PS-3D-15, cable labels are provided from cable 1, 2 and 3 to differentiate between them.

- Cover the antenna connectors with vulcanizing tape and vinyl tape, for waterproofing. Tie tape ends with a cable tie.

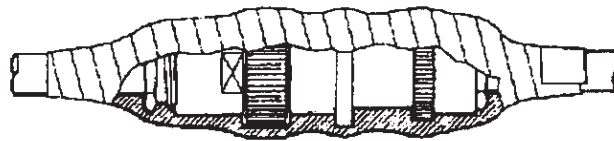

Waterproofing the antenna connector

- Set the joints of the coaxial cables into the cavity in the antenna base.
- Pass two cable ties (long life, temperature resistant type, local supply) through the hole shown in the figure below. Fasten them at the locations shown in the figure below.

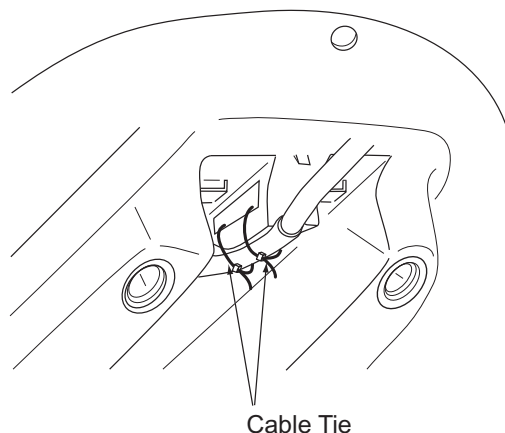

How to fasten the antenna cable

1. INSTALLATION

8. Set the “cable cover” to the antenna base as shown in the figure below.

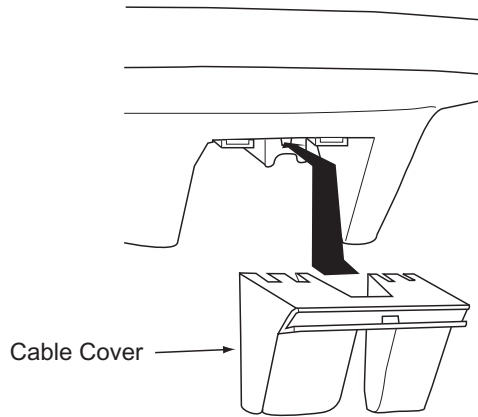

How to insert the cable cover

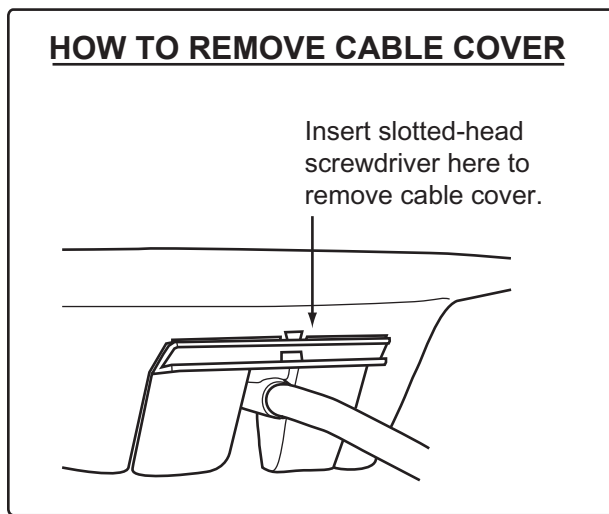

9. If necessary, attach nine “bird-repellent fixtures” (supplied) to the antenna cover as shown below. Use the paper pattern to position the fixtures.

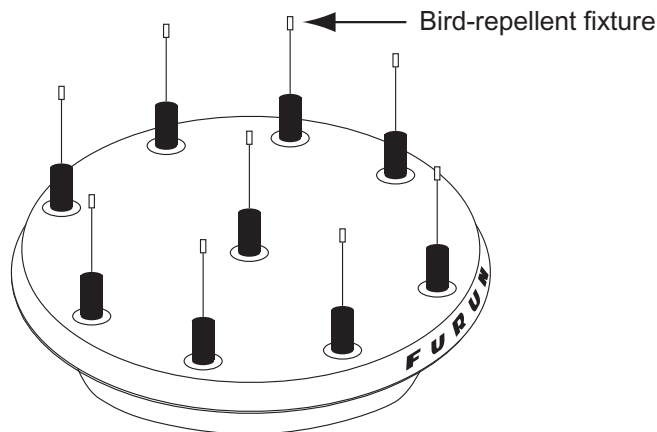

Antenna unit

10. Follow paragraph 1.6 to set up the equipment. If the status display shows “OK” the installation is suitable. If OK is not displayed, relocate the antenna.

1.2.2 Antenna unit SC-603

Note: “Bird-repellent fixtures” (supplied) may be attached to each antenna element and the Antenna Cover to prevent birds from alighting on the antenna. If it is more convenient to attach them before fixing the antenna unit to the mounting location, do step 10 in “Welding the antenna unit” before fixing the antenna unit.

Mounting

1. Screw in three antenna elements in the Antenna Base. Remove Antenna Cover and Arm Cover.

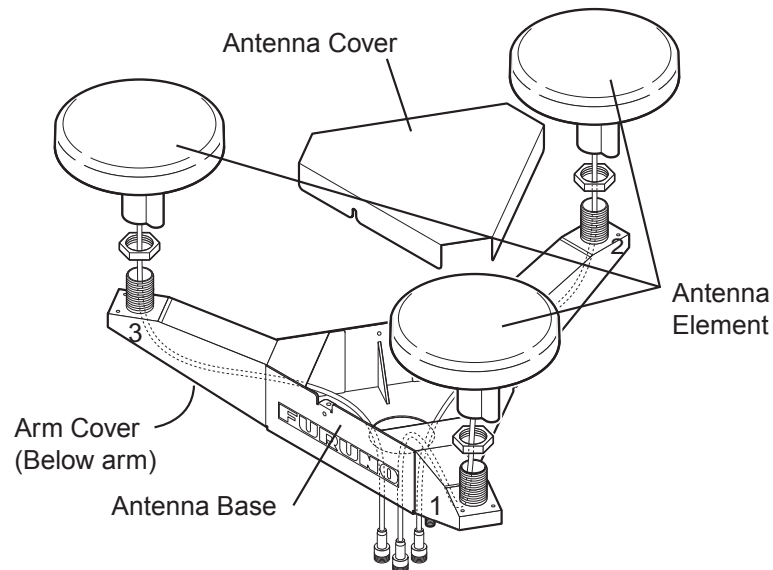

Antenna unit SC-603

2. Pass the coaxial cable from each antenna element through the center of the respective arm and then through the hole at the center of the antenna unit.
3. Orient the three antenna elements so that the protrusion on each faces the bow.

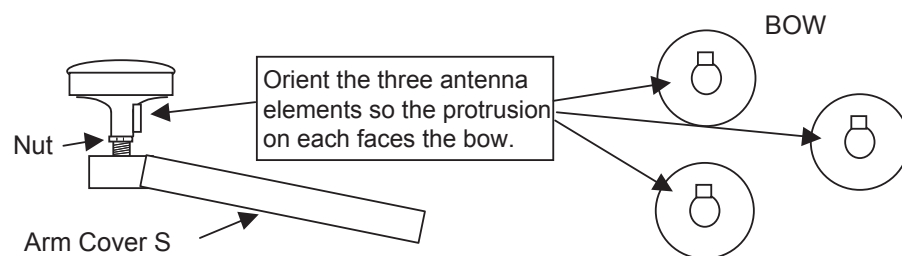

How to orient the antenna elements

1. INSTALLATION

- Making sure each antenna element is correctly oriented, fix each with its nut. Write the corresponding arm number on each coaxial cable, using a magic marker. (When connecting with the coaxial cables from the processor unit it is necessary to match correct antenna element number with coaxial cable color.)

Arm [1]	1
Arm [2]	2
Arm [3]	3

- Temporarily fix the pedestal and support plate to the antenna mast as shown in the illustration below. (The pedestal and support plate will be welded to the antenna mast after confirming that the installation site is suitable, following paragraph 2.6.)

Note: If U-bolts are used to temporarily fix the pedestal and support plate, DO NOT overtighten them – overtightening may deform the pedestal.

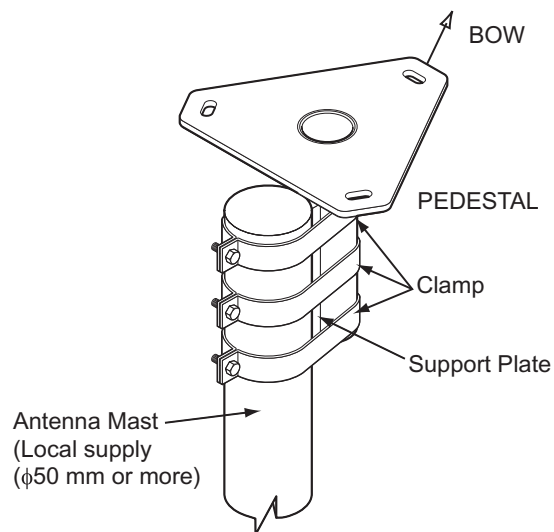

How to temporarily fix the support plate and pedestal to the antenna mast

- Set the antenna unit to the pedestal.

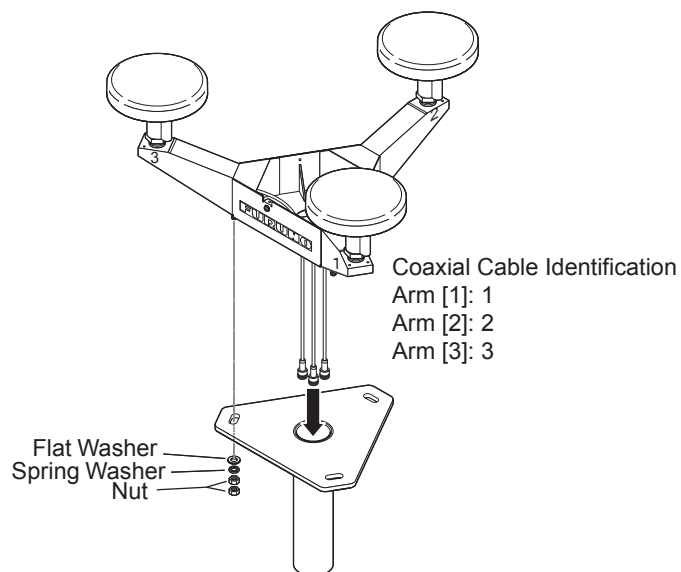

Fixing antenna unit to pedestal

7. Orient the antenna unit as shown in the illustration below.

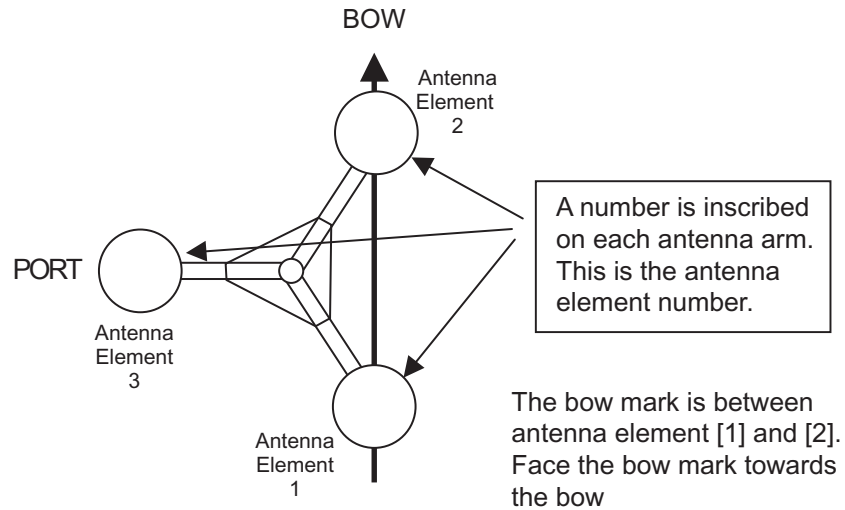

Orienting the antenna unit (top view)

NOTICE
The antenna unit should be positioned within $\pm 2.5^\circ$ of the bow.

8. Fasten the Antenna Cover with three screws.

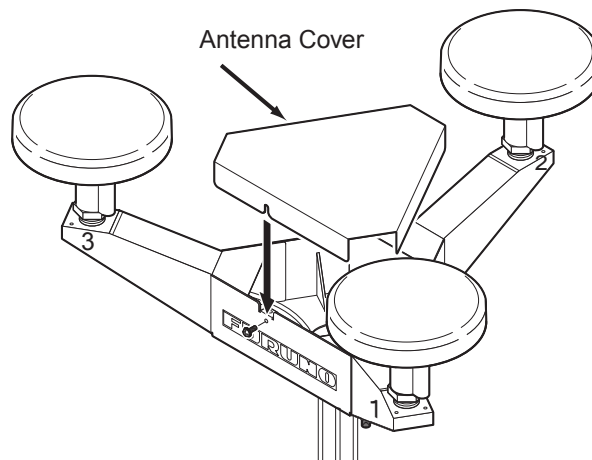

Antenna unit SC-603

9. Follow the instructions in the paragraph 2.6. If the satellite tracking status display shows “OK,” the installation site is suitable. Weld the antenna unit to the antenna mast as shown in the next paragraph.

1. INSTALLATION

Welding the antenna unit

The antenna unit may be welded to the antenna mast if the satellite status display shows "OK."

1. Unfasten the coaxial cables and dismount the antenna unit.
2. Weld the pedestal and support plate to the antenna mast. Remove the clamps used to temporarily fasten the pedestal and support plate.
3. Fasten the coaxial cables and fix the antenna unit.
4. Wrap the antenna connector with self-vulcanizing tape and then vinyl tape for waterproofing as shown in the illustration below. Tie tape ends with cable ties to prevent unraveling.

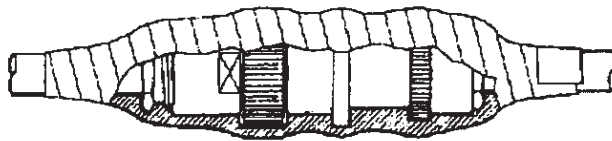

Waterproofing the antenna connector

5. Coat the three screws fixing the Antenna Cover S with Three Bond 1211 (supplied).

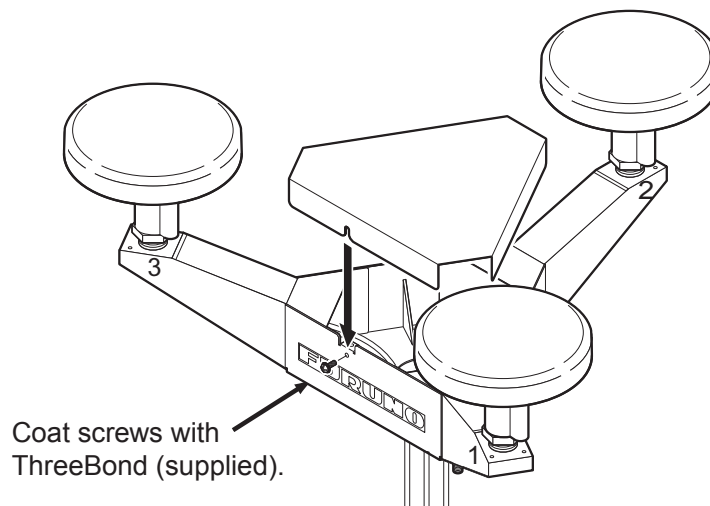

Antenna unit SC-603

6. Look at the heading indication on the display. If the heading error is between 5° and 10° , loosen the nut at the center of the antenna unit and adjust antenna orientation, while watching the heading indication on the display.

7. Make a loop in the antenna cable as shown in the illustration below. Fasten the antenna cable to the antenna mast with cable ties.

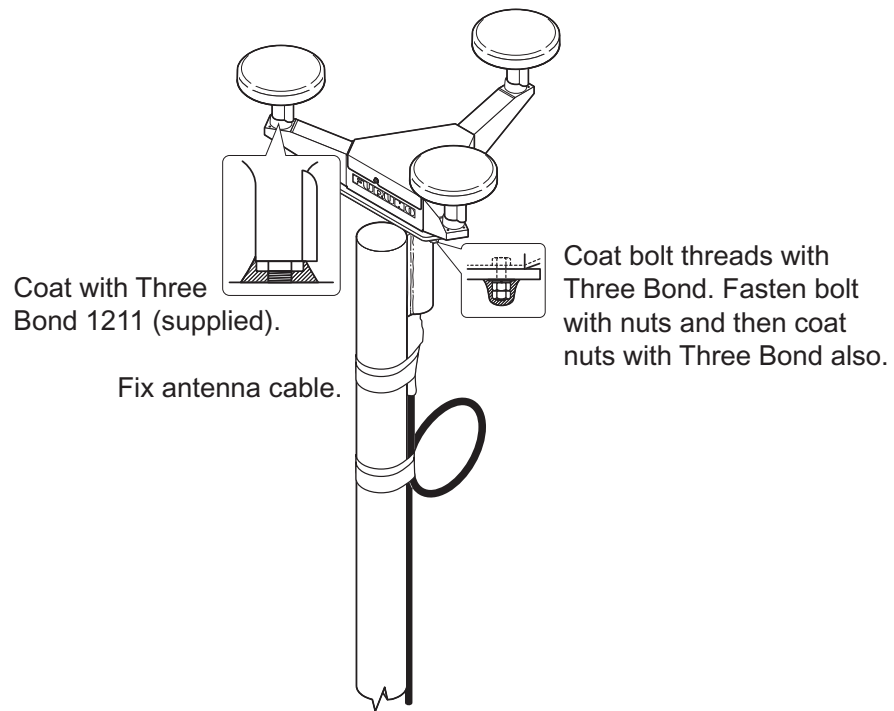

Fastening the antenna cable

8. Coat bolt threads and nuts at the bottom of each antenna element with Three Bond 1211.
9. Paint pedestal and support plate with anti-corrosive paint.
10. If necessary, attach the “bird-repellent fixtures” (supplied) to each antenna element and the Antenna Cover S as shown below.

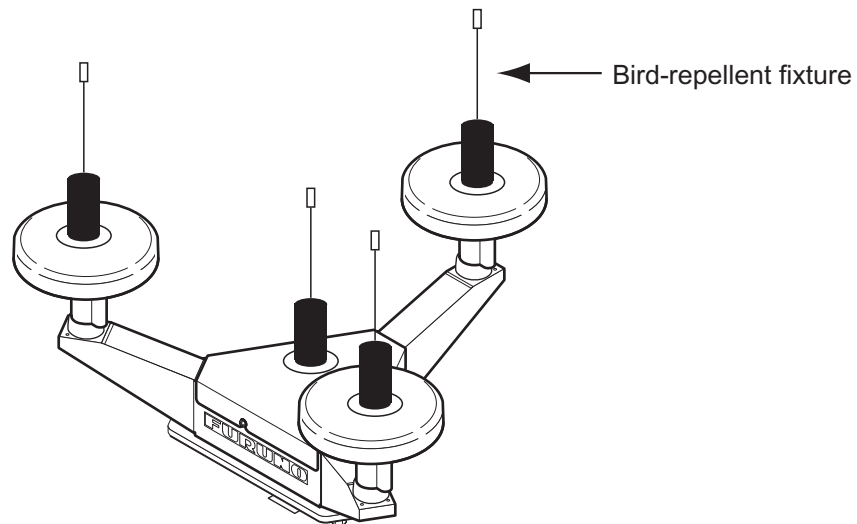

Antenna element

1.3 Installing the Processor Unit

The processor unit should be mounted aligned with the ship's fore-and-aft line. It can be mounted on the deck, bulkhead, or on the underside of a desk. Choose a mounting location which allows you to easily view the power lamp on the top of the unit and which is within $\pm 2.5^\circ$ of the ship's fore-and-aft line.

1.3.1 Bulkhead mount

The processor unit is shipped from the factory ready for bulkhead mounting. Orient the processor unit as shown below and fix it to the mounting location with four tapping screws (M5x20). You will set the orientation later on the menu.

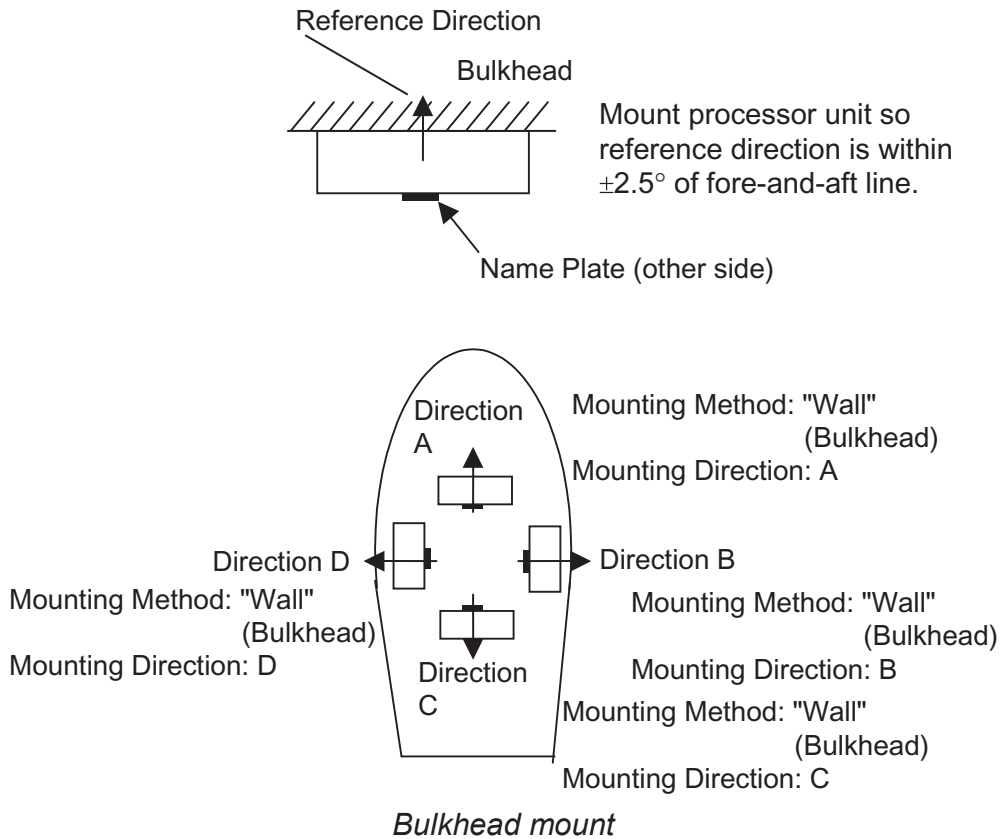

1.3.2 Deck mount

Orient the processor unit as shown below and fix it to the mounting location with four tapping screws (M5x20). You will set the orientation later on the menu.

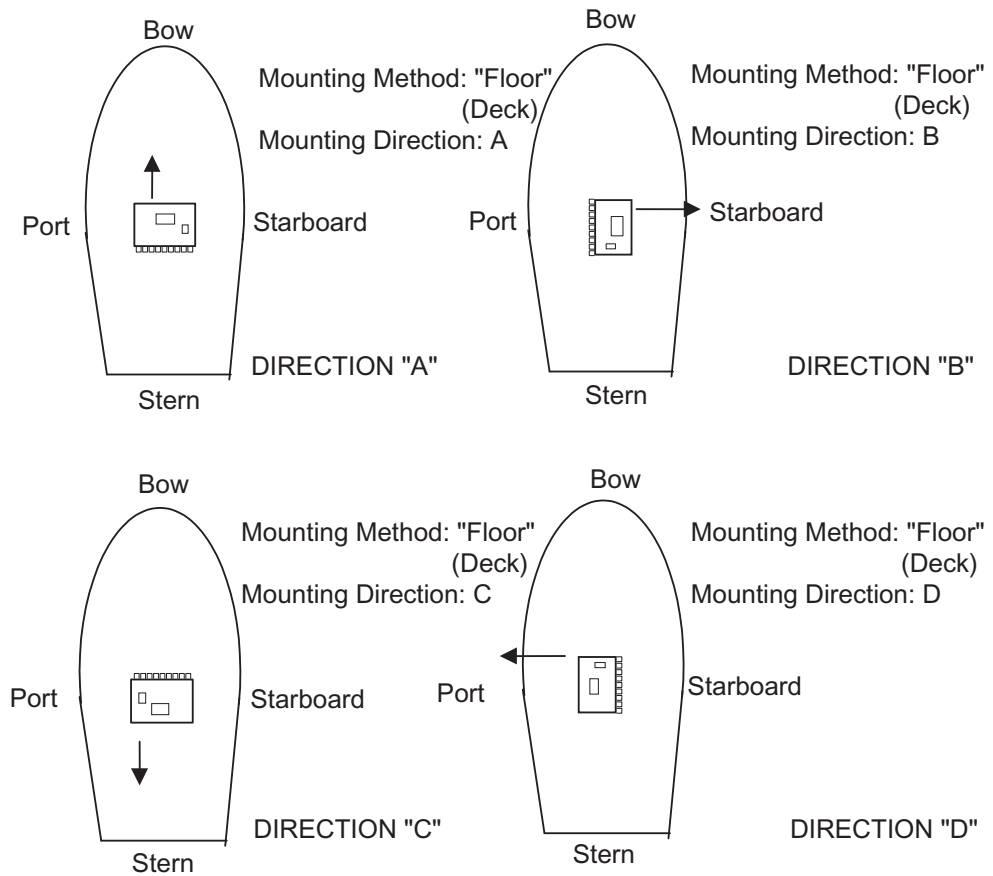
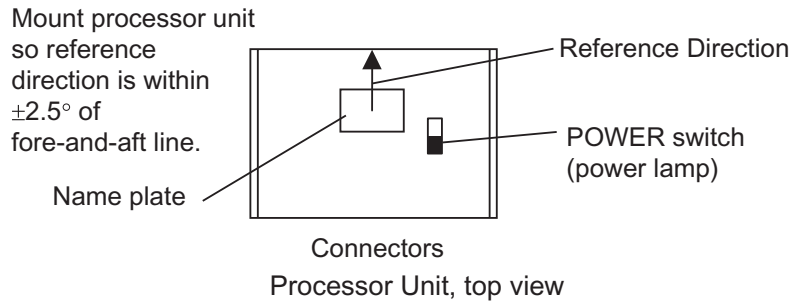

Processor unit orientation, deck mounting

1.3.3 Installation on the underside of a desk

The processor unit may be mounted on the underside of a desk as shown in the figure below. **Do not install it on the overhead.**

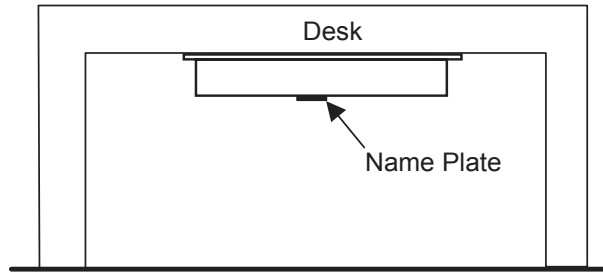

Installation of processor unit on the underside of a desk

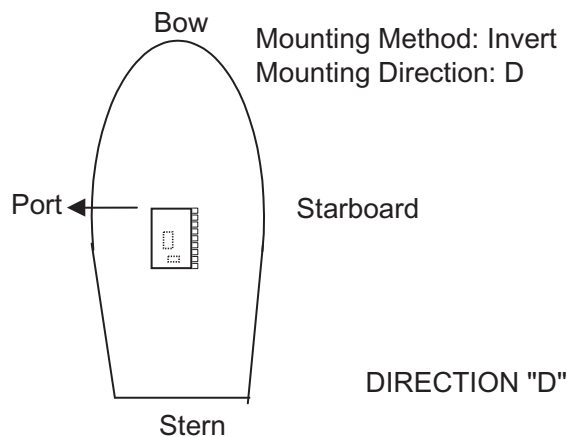
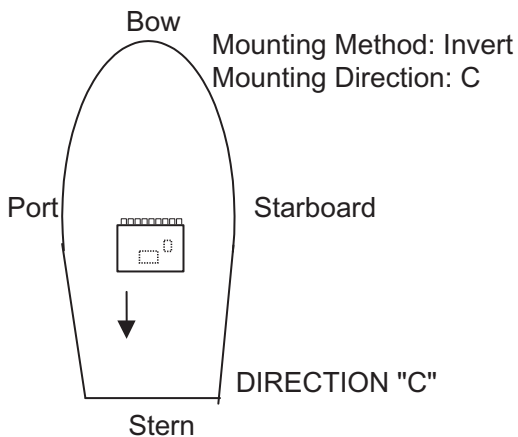
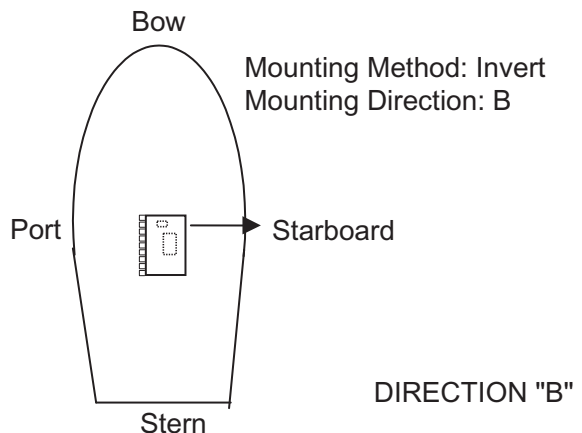
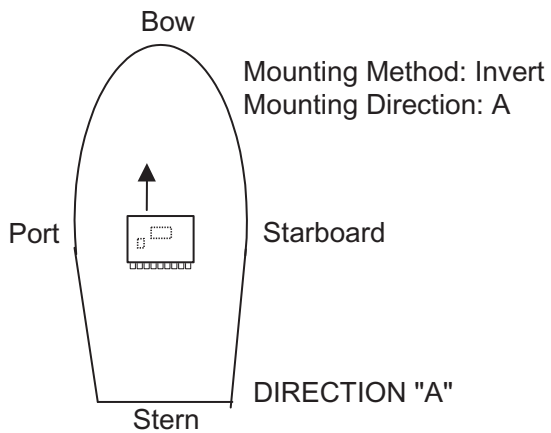
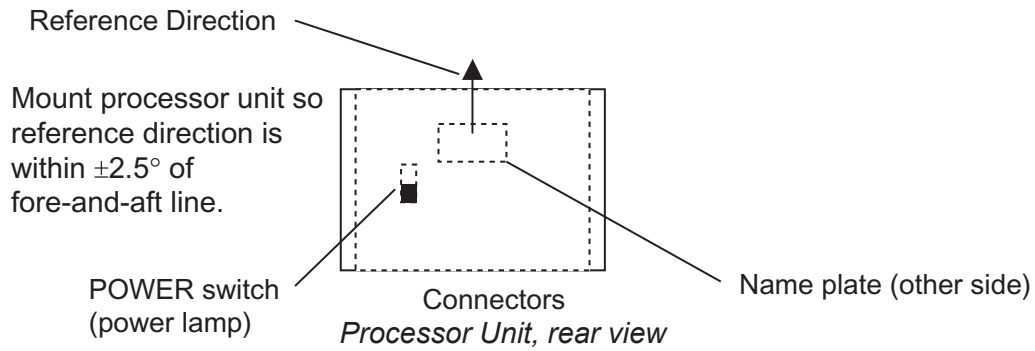

Mounting on underside of desk

1.4 Installing the Display Unit

The display unit can be installed on a desktop, overhead, or flush mounted in a console.

The optimal viewing distance is 0.5 m.

1.4.1 Desktop, overhead mounting

1. Fasten the hanger to the mounting location with four tapping screws (supplied). See the outline drawing for mounting dimensions.
2. Screw the knobs into the display unit.
3. Set display unit to the hanger and tighten the knobs.
4. Run the ground wire between the ground terminal on the display unit and the ship's superstructure.

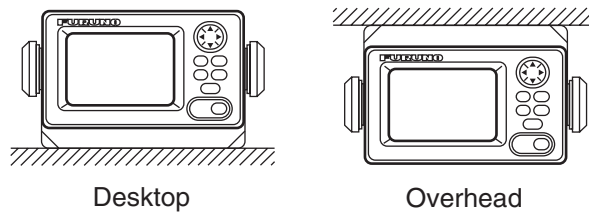

Display unit mounting methods

1.4.2 Flush mount

Two types of flush mounts are available. See the outline drawing at the back of the manual for details.

Flush mount "F"

Flush mount "F" kit Type: OP20-29, Code No: 000-041-405)

Name	Type	Code No.	Qty
Cosmetic Panel	20-016-1051	100-251-370	1
Tapping Screw	5X20	000-802-840	4
Hex Bolt	M6X12	000-862-127	2
Spring Washer	M6	000-864-260	2

1. Make a cutout in the mounting location. The dimensions are 183(W) x 92(H) mm.
2. Fasten the cosmetic panel to the display unit with hex bolts and spring washers.
3. Fasten the display unit to the mounting location with tapping screws.

1. INSTALLATION

Flush mount "S"

Flush mount "S" kit Type: OP20-17, Code No.: 000-040-720)

Name	Type	Code No.	Qty
Flush Mount Fixture	20-007-2401	100-183-190	2
Wing Bolt	M4X30	000-804-799	4
Wing Nut	M4	000-863-306	4
Hex Bolt	M6X12	000-862-127	2
Spring Washer	M6	000-864-260	2

1. Make a cutout in the mounting location. The dimensions are 167(W) x 92(H) mm.
2. Place the display unit in the cutout.
3. Fix the display unit to the two flush mount fixtures with hex bolts and spring washers.
4. Screw the butterfly nut on the butterfly bolt.
5. Fix the display unit with the butterfly bolt and then tighten the butterfly nut.

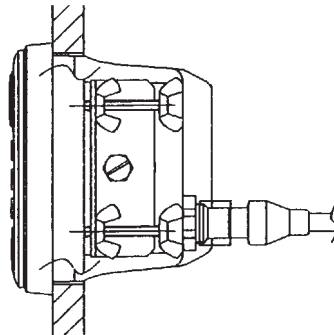

Flush mount "S"

1.5 Wiring

This section covers general wiring. For further details see the interconnection diagram at the back of this manual.

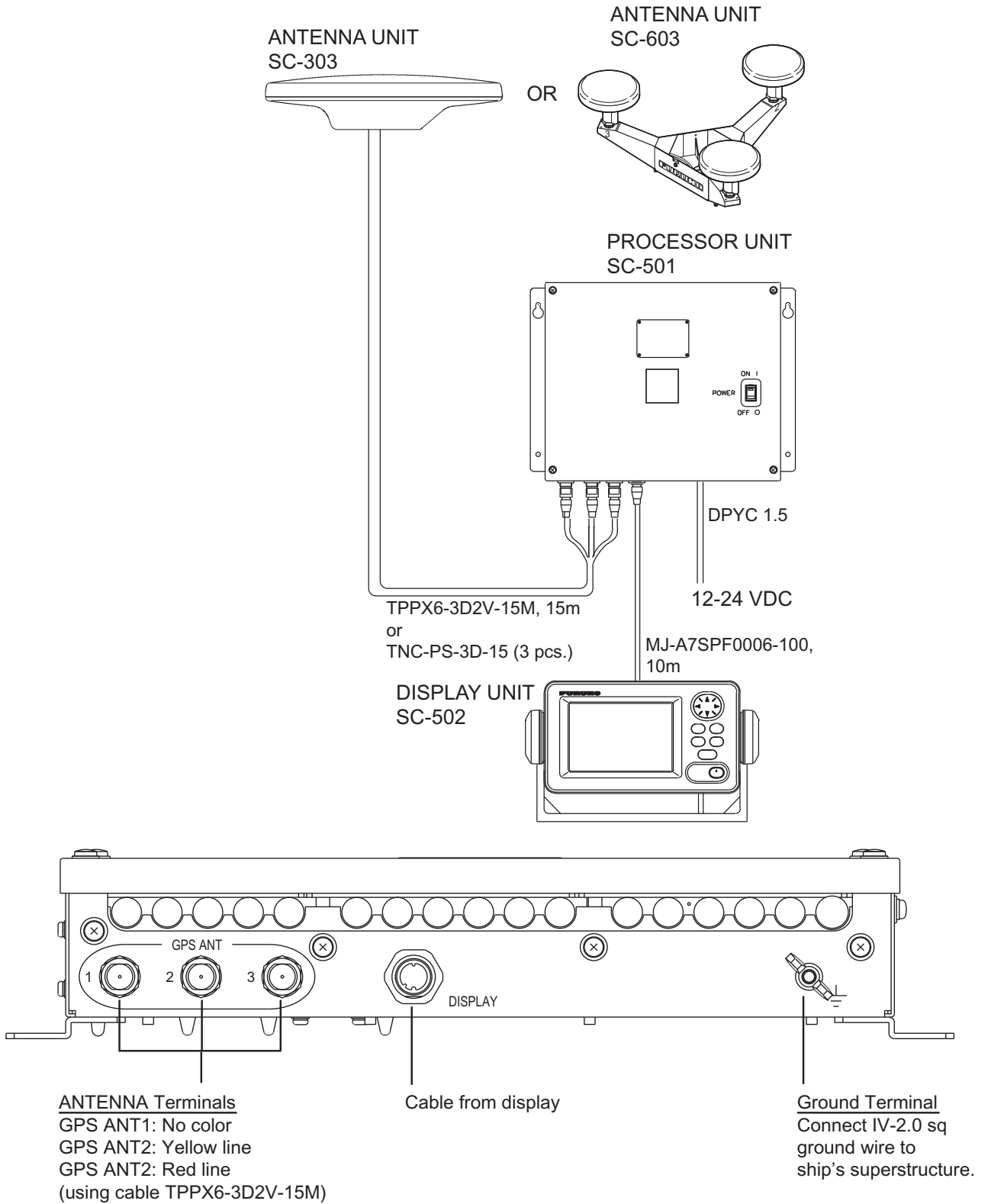

Wiring

1. INSTALLATION

Note 1: Use cable type DPYC-1.5 (or equivalent) for the power cable.

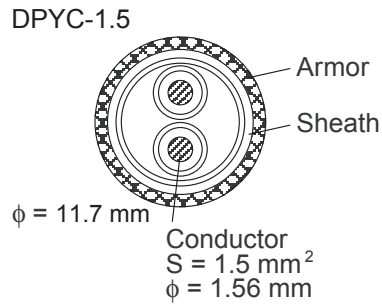

Sectional view of coaxial cable DPYC-1.5

Note 2: The optional antenna cable set (CP20-01700 or CP20-01710) allows you to extend antenna cable length to 30 m (50 m). See next page for how to attach the connector.

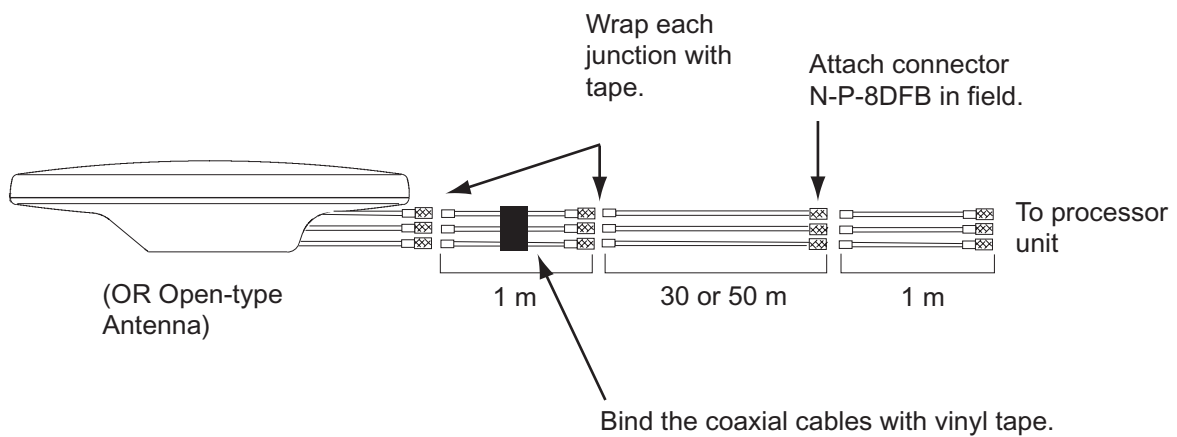

How to install the optional antenna cable set

How to attach connector N-P-8DFB

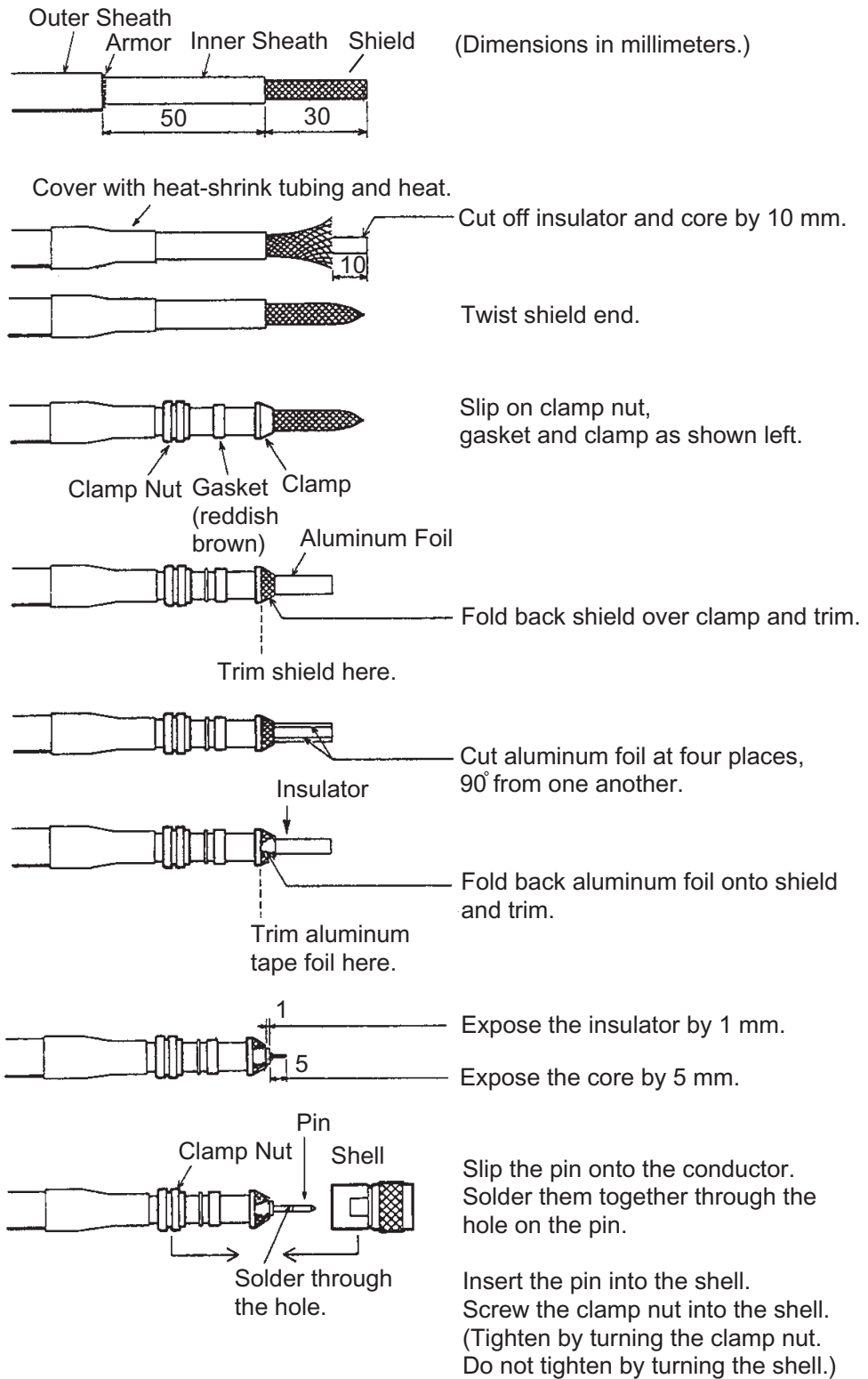

How to attach connector N-P-8DFB

1.6 Initial Settings

Follow the procedures in this section to enter initial settings.

NOTICE
Improper menu settings may stop output of data and display the message "RATE ERROR." Be sure to enter correct data.

1.6.1 Confirming satellite status

Press the [SAT STATUS] key.

Satellites used for measurement

SAT TRACKING STATUS			
TIMER 5 '52"			OK
Satellites being tracked	NO.	GOOD	STATUS
GPS1	8	8	D3D
GPS2	7	7	D3D
GPS3	8	8	D3D

"OK" displayed when the "GOOD" column shows that the number of satellites acquired is five or more.

"3D" shown when no beacon receiver is used. "W3D" shown when receiving WAAS.

Satellite tracking status display

When the system is turned on for the first time it is in the "cold-start" state, which means there is no satellite data (almanac data) stored. In this condition it takes about 12 minutes to find heading. When heading is found the display shows "OK." The timer at the top left corner of the screen shows time since power on. If OK is not displayed within 30 minutes after turning on the power, the antenna mounting location may not be suitable. Suspect that the number of satellites in view is less than five due to signal blockage. (For the open-type antenna, loosen the nut at the center of the antenna unit to adjust antenna orientation.) Resolve the problem and then recheck tracking status.

If the heading error is between 5° and 10°, adjust orientation of the antenna unit, while watching the heading indication on the display.

1.6.2 Choosing mounting method

1. Turn on the processor unit and then press the [MENU] key to show the menu.

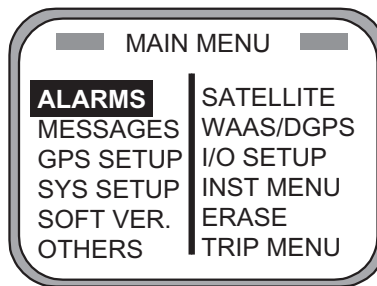

Main menu

2. Use the Omnipad (⊕) to choose "INST MENU" and then press the [ENT] key.

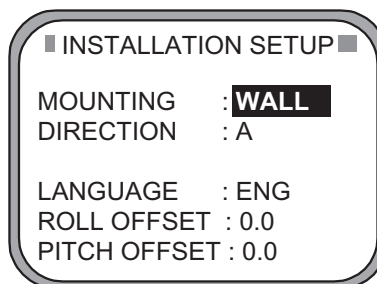

Installation setup menu

3. "MOUNTING" is selected; press the [ENT] key.
4. Use the Omnipad to choose the mounting method: "FLOOR", "WALL" or "INVERT" as appropriate.
5. Press the [ENT] key.
6. "DIRECTION" is selected; press the [ENT] key.
7. Use the Omnipad to choose mounting direction ("A", "B", "C" or "D") as appropriate. Refer to section 1.3.
8. Press the [ENT] key.

1.7 Connection of External Equipment

1.7.1 General wiring

All external equipment are terminated on the MAIN Board inside the processor unit. Turn off the power and unfasten four screws to remove the cover. Connect wiring from external equipment referring to the interconnection diagram. Use the terminal opener supplied to open terminal blocks, referring to the instructions below.

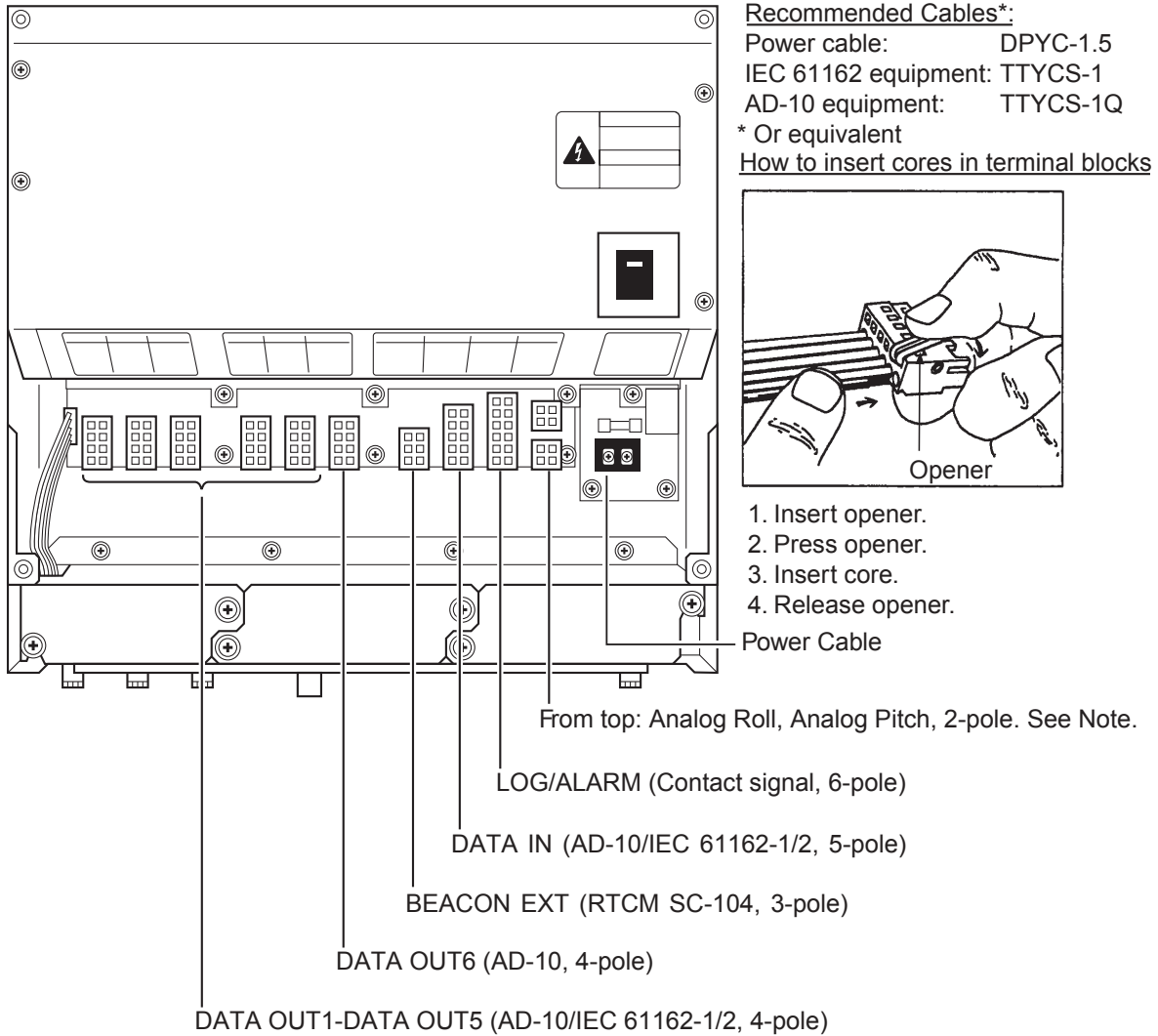

Processor unit, cover opened

Note 1: Attach labels (supplied) to cables to differentiate between them.

Note 2: A plastic sheet is placed across the cable glands of the processor unit to keep out foreign material. Cut out holes in the plastic where cables are to be lead in.

Note 3: Roll, pitch analog out voltage [V] = 0.0785 x θ (deg.) + 3.5 (θ = roll, pitch angle)
Output example

Roll or pitch angle	Analog out voltage
0 [deg]	3.5 [V]
5 [deg]	3.8925 [V]
10 [deg]	4.285 [V]
20 [deg]	5.07 [V]

1.7.2 Fabrication of cables

Cable	Sectional view, fabrication
<p>Power cable DPCY-1.5 (or equivalent)</p>	<p>SECTIONAL VIEW</p> <p>$\phi = 11.7 \text{ mm}$ Conductor $S = 1.5 \text{ mm}^2$ $\phi = 1.56 \text{ mm}$</p> <p>FABRICATION</p> <p>Labels: Armor, Sheath, Sheath, Armor, Cut the sheath., Crimp-on lug FV1.25-5, Vinyl tape, Lay in clamp where paint was removed.</p>
<p>Cable for IEC 61162 format equipment (JIS cable TTYCS-1 or equivalent)</p> <p>Cable for AD-10 format equipment ((JIS cable TTYCS-1Q or equivalent)</p>	<p>SECTIONAL VIEW (TTYCS-1)</p> <p>$\phi = 10.1 \text{ mm}$ Conductor $S = 0.75 \text{ mm}^2$ $\phi = 1.11 \text{ mm}$</p> <p>SECTIONAL VIEW (TTYCS-1Q)</p> <p>$\phi = 11.3 \text{ mm}$ Conductor $S = 0.75 \text{ mm}^2$ $\phi = 1.11 \text{ mm}$</p> <p>FABRICATION</p> <p>Labels: Braided shield, Armor, Twist and cut., Four cores on TTYCS-1Q, Solder, Ground wire (70), Remove paint by 40 mm, clamp this part in cable clamp., Vinyl tape.</p>

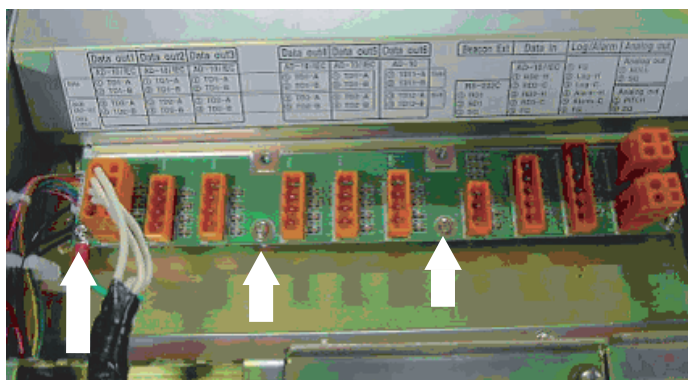

NOTE ON WIRING

1) Ground both this unit and external equipment.

- 2) Fabricate braided shield of external equipment as follows:
- IEC 61162-1 input, AD-10 input (photo coupler): Connect to FG(frame ground).
 - IEC 61162-2 input (RS-422/485): Connect to SG(signal ground).

Note: The power section of this equipment is insulated so the potential of SG and FG are the same. If the shielding is not properly done, the data output IC may be damaged.

1. INSTALLATION

(This page intentionally left blank.)

2 OPERATION

2.1 Controls

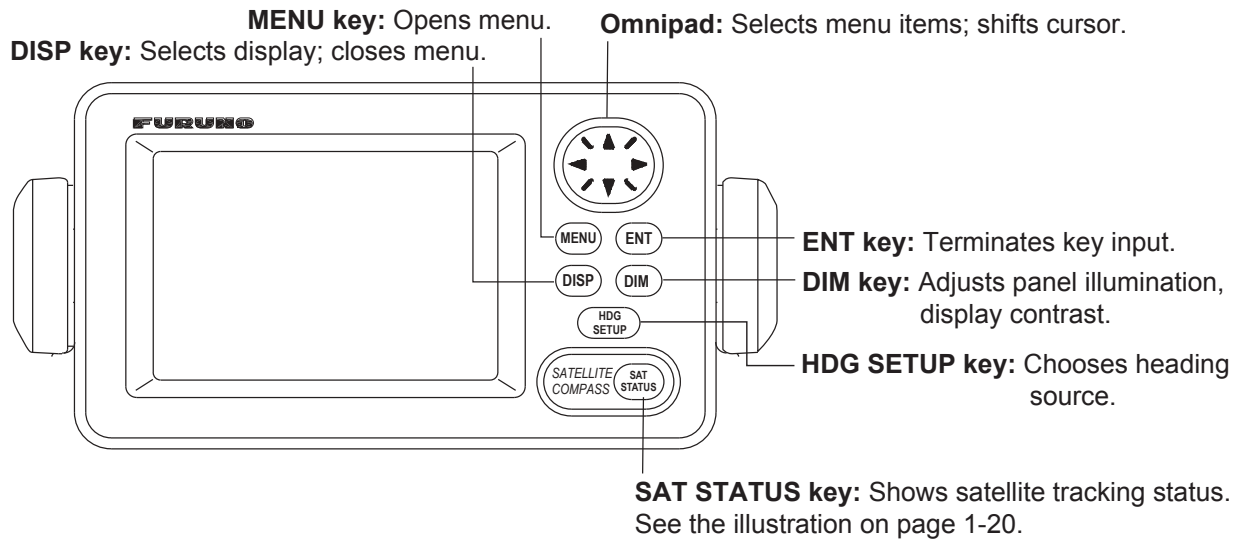

HOW TO REMOVE THE COVER

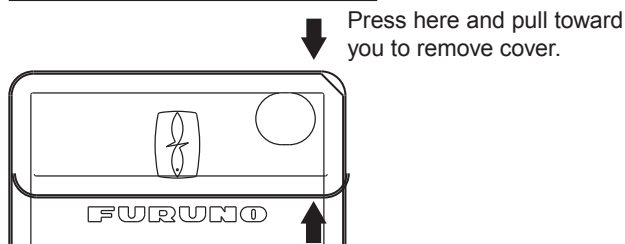

Display unit

NOTICE

Reduced accuracy may occur in case of unfavorable satellite constellation, worsened HDOP, etc.

Always confirm position against other navigation devices to verify reliability.

2.2 Turning the Power On/Off

Use the power switch on the processor unit to turn the power to the display unit on and off.

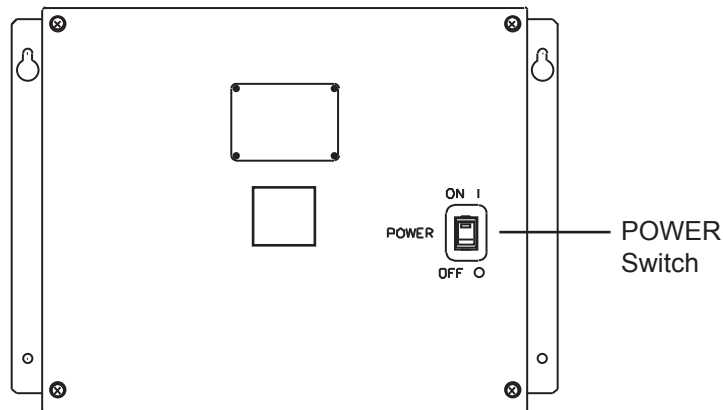

Processor unit

A beep sounds and the display starts up with the last-used display.

Note: If backup heading data is used the heading indication flashes until faithful heading data becomes available.

2.3 Panel Illumination, Display Contrast

Adjust panel illumination and display contrast as shown below. The default values are 4 and 45, respectively.

1. Press the [DIM] key.

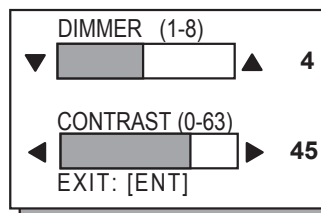

Dialog box for adjustment of panel illumination, display contrast

2. Press ▲ or ▼ to adjust panel illumination (dimmer).
3. Press ◀ or ▶ to adjust display contrast.
4. Press the [ENT] key.

Note 1: Default illumination and contrast settings are restored whenever All backup data is erased. See section 3.5.

Note 2: The contrast is automatically set to 36 if the power is turned with the contrast set below 36.

2.4 Choosing a Display

Use the [DISP] key to show a display desired.

Heading display

The heading display shows heading, course, speed, date, time and position-fixing status. The heading status mark changes in the sequence shown below. The “final calculations” mark disappears after heading becomes reliable, which is approximately 90 seconds after that mark appears.

Position-fixing status indications

2D	2D GPS position fix
3D	3D GPS position fix
D2D	2D DGPS position fix
D3D	3D DGPS position fix
SIM	Simulation mode
W2D	WAAS 2D position fix
W3D	WAAS 3D position fix

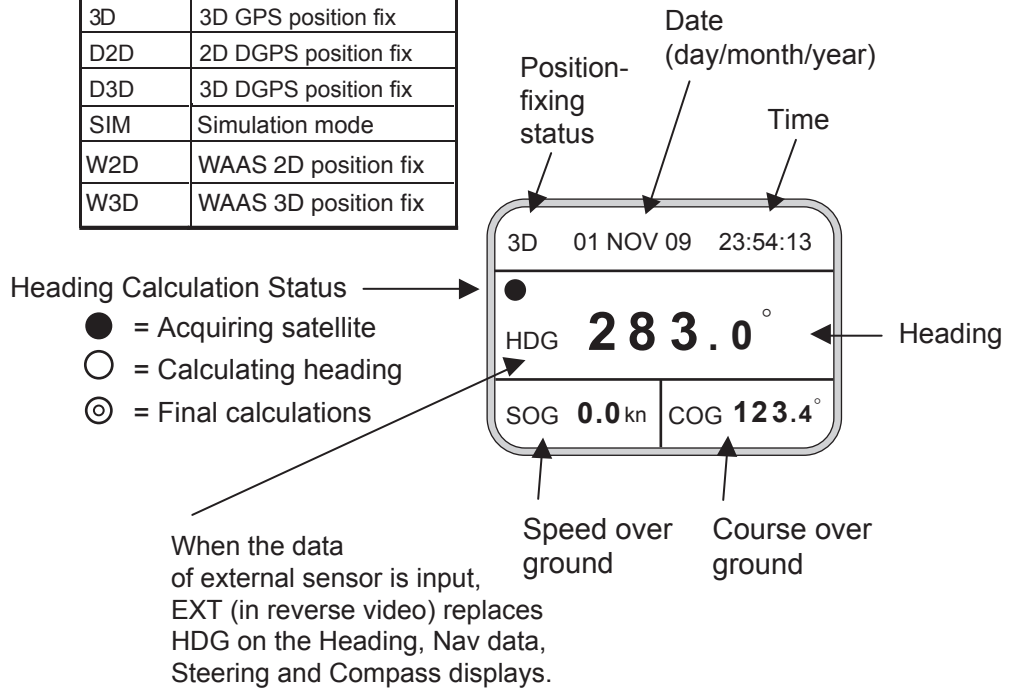

When the heading source is selected to AUTO (see section 2.14), the following mark appears when switching from internal heading to external heading and vice versa.

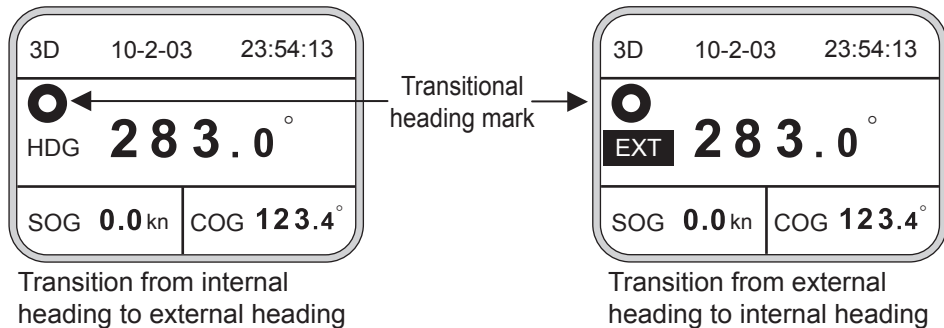

Heading displays when heading source is AUTO

Nav data display

The nav data display shows position in latitude and longitude, speed, heading, date, time and position-fixing status.

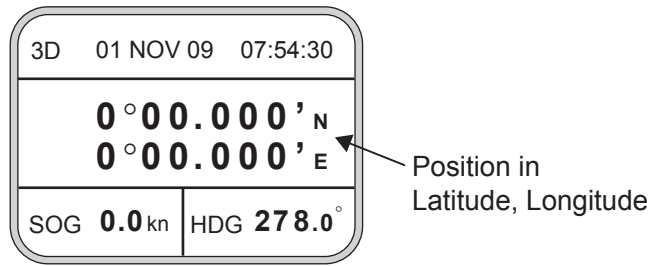

Nav data display

Steering display

The steering display shows heading in digital and analog form. SOG and COG are also indicated. Note that COG accuracy is low when the own ship speed is low. The faster the speed, the more accurate the COG.



Steering display

Compass display

The compass display shows heading by compass direction. Pitch and roll are also indicated. The compass rose rotates with heading.

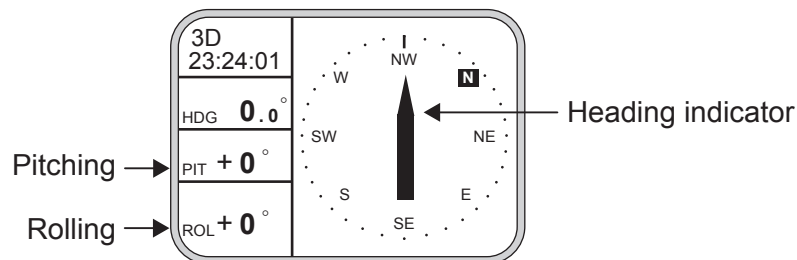

Compass display

ROT (Rate-of-Turn) display

The ROT display provides digital and analog indications of rate of turn.

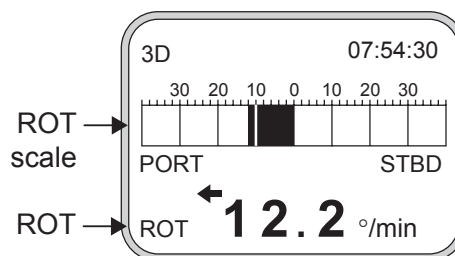

ROT display

Speed display

Depending on the setting of DISTANCE DISP on the TRIP menu, the Set and Drift display or the Distance Run display is shown. The current indication requires a Doppler Speed Log.

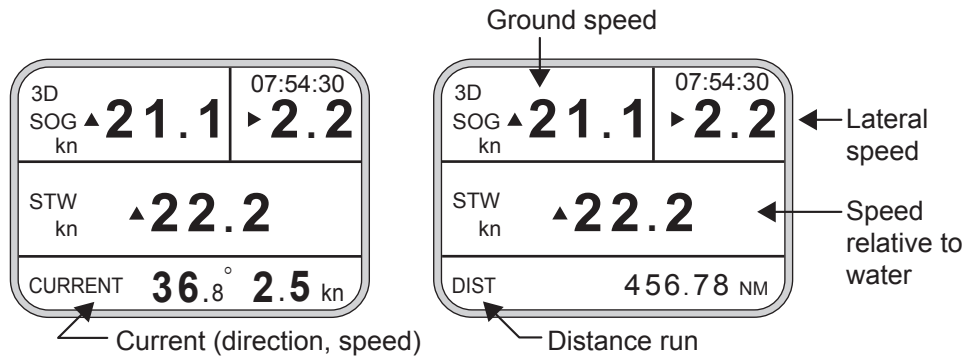

SOG/STW display

2.5 Alarm Setup

The SC-50 can alert you with audible and visual alarms when GPS signal, DPGS signal and WAAS signal are lost. To set the DGPS alarm, do the following:

1. Press the [MENU] key to show the menu.
2. Choose ALARMS and then press the [ENT] key.

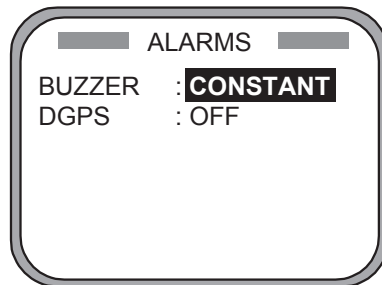

Alarm menu

3. BUZZER is selected; press the [ENT] key.



Buzzer options

4. Use ▲ or ▼ to choose buzzer type desired and then press the [ENT] key.

SHORT: Two short beeps
 LONG: Three long beeps
 CONSTANT: Continuous beep (default setting)

Note: IEC 62288 regulations require that the buzzer sound until a violated alarm is acknowledged. Thus this setting will not take effect immediately if there is an unacknowledged alarm.

5. Press the [ENT] key.
6. DPGS is selected; press the [ENT] key.



DGPS alarm options

7. Use ▲ or ▼ to choose OFF or ON as appropriate.
8. Press the [ENT] key.
9. Press the [DISP] key to close the menu.

2.6 Confirming Satellite Status

You can check the receiving condition of each antenna unit as follows:

1. Press the [MENU] key to open the menu.
2. Choose SATELLITE and then press the [ENT] key.

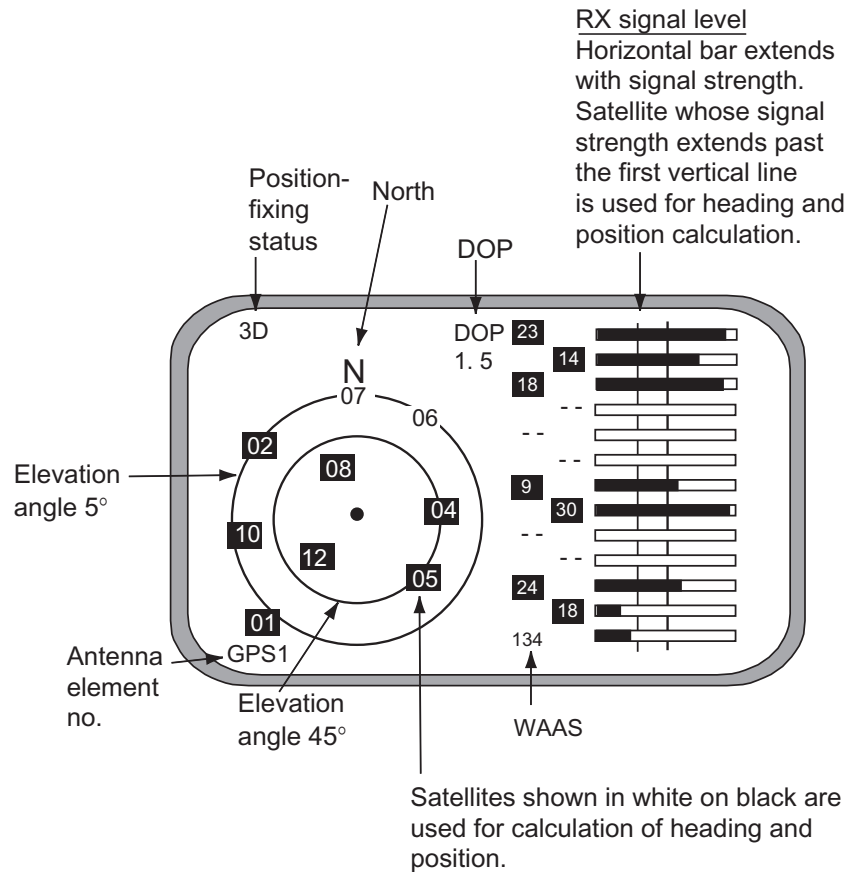

Satellite status display

3. Use ◀ or ▶ to choose antenna element for which to confirm receiving status.
4. Press the [DISP] key to close the menu.

2.7 GPS Setup

The GPS SETUP menu smoothes position and course, averages speed, applies position offset, and deactivates unhealthy satellites.

2.7.1 Displaying the GPS setup menu

1. Press the [MENU] key to open the menu.
2. Choose GPS SETUP and then press the [ENT] key.

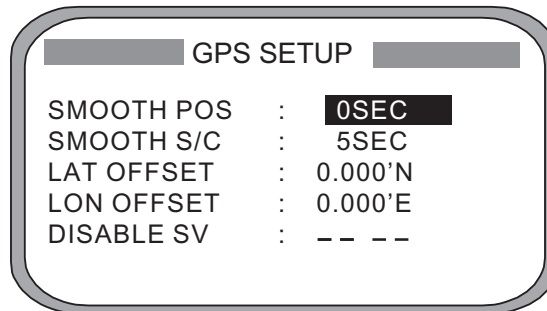

GPS SETUP menu

2.7.2 GPS SETUP menu description

SMOOTH POS (Smoothing position)

When the DOP (Dilution of Precision, the index for position-fixing accuracy) or receiving condition is unfavorable, the GPS fix may change randomly, even if the vessel is at anchor. This change can be smoothed by averaging a number of GPS fixes. The setting range is from 0 (no smoothing) to 999 seconds. The higher the setting, the more smoothing. However, too high a setting slows updating of position.

SMOOTH S/C (Smoothing speed/course)

Ship's speed and course are directly measured by receiving GPS satellite signals, independent of positions. The data varies with receiving conditions and other factors. You can reduce this random variation by increasing the smoothing. The higher the setting, the more that speed and course are smoothed. If the setting is too high, however, the follow-up to actual values gets slower. The setting range is from 0 (no smoothing) to 999 seconds.

LAT/LON OFFSET (L/L position offset)

If GPS fixes are erroneous while at anchor, enter a position offset to compensate for position error. Consult a nautical chart to determine latitude and longitude differences between the chart and GPS display. Enter that value as the offset.

DISABLE SV (Disable satellite)

Every GPS satellite is broadcasting abnormal satellite number(s) in its Almanac, which contains general orbital data about all GPS satellites. Using this information, the GPS receiver automatically eliminates any malfunctioning satellite from the GPS satellite schedule. However, the Almanac sometimes may not contain this information. If you hear of an inoperative satellite you can disable it manually. Enter satellite number in two digits and then press the [ENT] key. To restore a satellite, enter "00".

2.8 Output Data**2.8.1 Heading**

Heading data is output from the DATA OUT port on the processor unit, in IEC 61162-1/2 format.

1. Press the [MENU] key to open the menu.
2. Choose I/O SETUP and then press the [ENT] key.

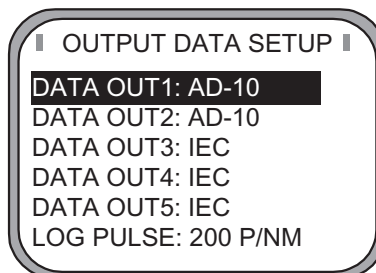

OUTPUT DATA SETUP menu

3. Choose DATA OUT1 and then press the [ENT] key.



Data out options

4. Use the Omnipad to choose AD-10 or IEC as appropriate and then press the [ENT] key. If you choose AD-10, no further operation is required; go to step 18 to finish. For IEC go to the next step.

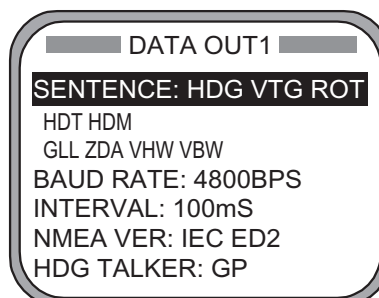

DATA OUT1 menu

2. OPERATION

5. Choose SENTENCE and then press the [ENT] key.

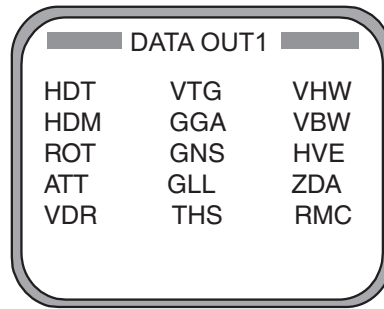

DATA OUT1 menu, sentences

6. Use the Omnipad to choose a sentence and then press the [ENT] key.
 - HDT: True heading (required for radar, AIS, ECDIS, etc.)
 - HDM: Magnetic heading (HDM is obtained in this equipment by adding the magnetic variation to HDT.)
 - THS: True heading and status
 - ROT: Rate-of-turn data
 - ATT: True heading, pitching, rolling (FURUNO's proprietary sentence)
 - VDR: Set and drift
 - VTG: Course over ground and ground speed
 - GGA: Global positioning system (GPS) fix data
 - GNS: GNSS fix data
 - GLL: Geographic position, latitude/longitude
 - VHW: Water speed and heading
 - VBW: Dual ground/water speed
 - HVE: GPS antenna up-down motion amplitude (FURUNO proprietary sentence)
 - ZDA: Time and date
 - RMC: Recommended minimum specific GNSS data



7. Use the Omnipad to choose OFF or ON as appropriate and then press the [ENT] key. Sentences selected for output are marked with an asterisk.
8. Repeat steps 6 and 7 for other items. All sentences cannot be selected. The message "SENTENCE OVERLOAD" appears when too many sentences have been selected. Change settings as appropriate. For further information see page 2-12.
9. Press the [MENU] key to return to the DATA OUT1 menu.
10. Choose BAUD RATE and then press the [ENT] key.

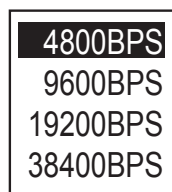

Baud rate options

11. Use the Omnipad to choose the baud rate of the equipment connected and then press the [ENT] key.
12. INTERVAL is selected; press the [ENT] key.

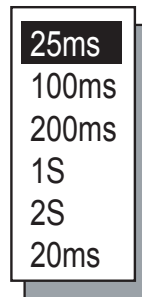

Tx interval options

13. Use the Omnipad to choose appropriate output interval and then press the [ENT] key.
14. Choose IEC VERSION and then press the [ENT] key.

Note: The sentences VTG, GLL, GGA and VBW differ between ED1 and ED2.

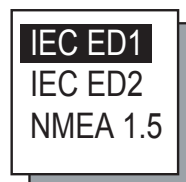

IEC, NMEA version options

15. Choose appropriate IEC (or NMEA) edition and then press the [ENT] key.
16. Choose HDG TALKER and then press the [ENT] key.

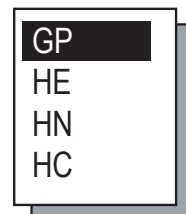

Heading talker options

17. Choose appropriate heading talker and then press the [ENT] key.

GP: GPS navigator talker

HE: North-seeking gyrocompass talker

HN: Non-north seeking gyrocompass talker

HC: Magnetic compass talker

18. Press the [DISP] key to close the menu, or press the [MENU] key to return to the I/O SETUP menu to setup another output port.

2. OPERATION

Output sentence limitation

The number of sentences which can be output depends on baud rate and output interval settings. The maximum number of characters per each data sentences are shown in the table below and the total number of characters must satisfy the formula shown below. The number of characters which can be output “N” is calculated by the following formula

$$N \leq 0.083 \times T \times B$$

T: Interval (s)

B: Baud rate

Sentence and maximum number of characters

Sentence	HDT	HDM	THS	ROT	ATT	HVE	VTG*	GGA*	GNS*	GLL*	ZDA*	VHW*	VBW*	VDR*	RMC*
No. of Characters	19	19	21	21	34	23	46	66	62	47	36	44	45	35	74

*: Output is 1 s if interval set is shorter than 1 s.

For example, the baud rate is 4800 bps, interval is 100 ms (= 0.1 s). Therefore, the number of characters is $N < 0.083 \times 0.1(\text{s}) \times 4800(\text{bps}) = 39.4$.

Then, the number of characters which can be output is 39. For sentences (sentences not having an asterisk in the table) where the output interval is variable the number of characters is as shown in the table, however sentences where the output interval is not smaller than 1 s (asterisk-marked sentences in table) the number of characters which can be output is “number of characters in table” x “setting interval.”

For the above settings the following applies:

- If both HDT and HDM are selected the total number of characters is $19+19 = 38$. Since the count is less than 39 both can be selected.
- If both HDT and VTG are selected the total number of characters is $19+46 \times 0.1 = 23.6$. Since the count is less than 39 both can be selected.
- If HDT, HDM and VTG are selected the total number of characters is $19+19+46 \times 0.1 = 42.6$. In this case, the message “SENTENCE OVERLOAD” appears.

2.8.2 Log pulse

This equipment provides SOG (speed over ground) in high accuracy. It converts an SOG value to a pulse signal and outputs at the rate of 200 or 400 pulses/NM.

1. Press the [MENU] key.
2. Choose I/O SETUP and then press the [ENT] key.
3. Choose LOG PULSE and then press the [ENT] key.



Log pulse options

4. Choose 200p/NM or 400p/NM as appropriate and then press the [ENT] key.
5. Press the [DISP] key to close the menu.

2.9 System Setup

2.9.1 Geodetic data

Your unit is preprogrammed to recognize most of the major chart systems of the world. Although the WGS-84 system (default setting) is the GPS standard, other categories of charts in other datum still exist. Match the GPS datum with the chart system you use.

1. Press the [MENU] key to open the menu.
2. Choose SYS SETUP and then press the [ENT] key.

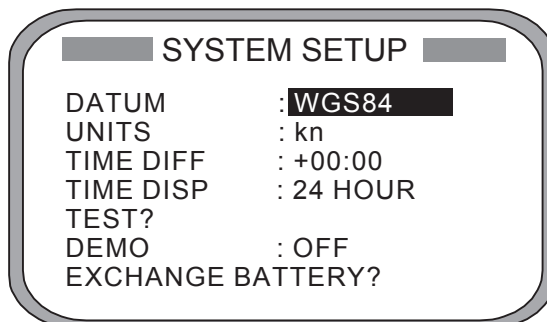

SYSTEM SETUP menu

3. Confirm that the cursor is selecting DATUM and then press the [ENT] key.
4. Choose WGS84 (GPS standard), WGS72 or OTHER according to the nautical chart you use and then press the [ENT] key.
5. If you chose WGS72 or WGS84, press the [DISP] key to finish. For OTHER, go to step 6.
6. Press the [ENT] key.
7. Use the Omnipad to enter chart number, referring to the geodetic chart list on page A-2. Choose location with ◀ or ▶; change value with ▲ or ▼.
8. Press the [ENT] key.
9. Press the [DISP] key to close the menu.

2.9.2 Units of measurement

Distance/speed can be displayed in nautical miles/knots, kilometers/kilometers per hour, or miles/miles per hour.

1. Press the [MENU] key to open the menu.
2. Choose SYS SETUP and then press the [ENT] key.
3. Choose UNITS.
4. Press the [ENT] key.
5. Choose unit of measurement combination desired; kt, km/h, mi/h.
6. Press the [ENT] key.
7. Press the [DISP] key to close the menu.

2.9.3 Using local time

GPS uses UTC time. If you would rather use local time, enter the time difference (range: -13:30 to +13:30) between local time and UTC.

1. Press the [MENU] key to open the menu.
2. Choose SYS SETUP and then press the [ENT] key.
3. Choose TIME DIFF and then press the [ENT] key.
4. Press ▲ or ▼ to display + or – as appropriate.
5. Enter time difference with the Omnipad. Choose digit with ◀ or ▶; change value with ▲ or ▼.
6. Press the [ENT] key.
7. Press the [DISP] key to close the menu.

2.9.4 Time format

Time can be displayed in 12 hour or 24 hour format.

1. Press the [MENU] key to open the menu.
2. Choose SYS SETUP and then press the [ENT] key.
3. Choose TIME DISP and then press the [ENT] key.
4. Choose 12HOUR or 24HOUR as appropriate and then press the [ENT] key.
5. Press the [DISP] key to close the menu.

2.9.5 Demonstration mode

The demonstration mode provides simulated operation of the equipment.

1. Press the [MENU] key to open the menu.
2. Choose SYS SETUP and then press the [ENT] key.
3. Choose DEMO and then press the [ENT] key.
4. Choose ON or OFF as appropriate and then press the [ENT] key.
5. Press the [DISP] key to close the menu.

The indication SIM appears at the top of the screen when the demonstration mode is active. Further, "S" appears on displays which show heading. When the demonstration mode is first made active, SIMULATION MODE appears when the power is turned on and it is erased when any key is pressed.

2.10 WAAS/DGPS Setup

1. Press the [MENU] key to open the menu.
2. Choose WAAS/DGPS and then press the [ENT] key.

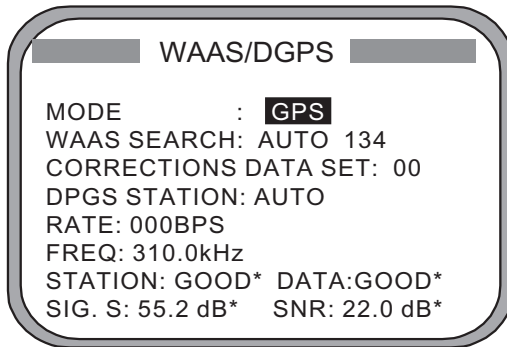

STATION: Shows GOOD or NG.

DATA: Shows GOOD or NG.

SIG. S: Signal Strength. A figure between 0 and 99 is shown. The higher the figure the stronger the beacon signal.

SNR: Signal to Noise Ratio. A figure between 1 and 22 is shown. When your boat is in the service area of a beacon station, SNR should be 21 or 22. If the figure is below 21 the position will be inaccurate. If this happens, check for radar interference, poor ground and generator noise on own ship.

WAAS/DGPS menu

3. MODE is selected; press the [ENT] key.

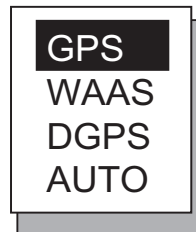

Position fix mode options

4. Choose appropriate mode referring to the description below and then press the [ENT] key.
 - GPS: Position fix by GPS
 - WAAS: Position fix by WAAS
 - DPGS: Position fix by DGPS (external beacon receiver required)
 - AUTO: Position fix in order of DGPS, WAAS and GPS
5. For WAAS or AUTO do as below. For DGPS go to step 6; for GPS go to step 8.
 - 1) WAAS SEARCH is selected; press the [ENT] key.

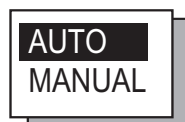

WAAS SEARCH options

2. OPERATION

- 2) Use the Omnipad to choose WAAS satellite search method, AUTO or MANUAL as appropriate. For MANUAL, press the [ENT] key, enter WAAS satellite number, referring to page AP-14 (7. What is WAAS?) and then press the [ENT] key.
- 3) CORRECTIONS DATA SET is selected; press the [ENT] key.
CORRECTIONS DATA SET determines how to use the WAAS signal. Use the default setting "00". Do step 6 and 7 for DGPS.
6. Choose DPGS STATION and press the [ENT] key.



AUTO/MANUAL options

7. Choose MANUAL or AUTO as appropriate and press the [ENT] key. For AUTO got to step 8. For MANUAL do the following:
 - 1) RATE is selected; press the [ENT] key.

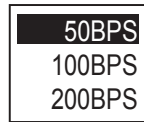

Baud rate options

- 2) Choose appropriate baud rate and press the [ENT] key.
- 3) FREQ is selected; press the [ENT] key.
- 4) The cursor is selecting the hundredths digit so press ▲ or ▼ to display appropriate digit. Press ► to shift the cursor to the tenths place.
- 5) Set other digits appropriately.
8. Press the [DISP] key to close the menu.

2.11 OTHERS Menu

The OTHERS menu contains the following items:

HOLD HDG DATA: Choose whether to display last-used heading data at power on or not. This data is not reliable.

HDG RESTORATION: Choose how to restore GPS signal, automatically or manually, after it is lost. For manual restoration, a key must be pressed to restart heading output. This is done for safety purposes; for example, when an autopilot is used.

HDG BACKUP: Choose how long to display backup data when the GPS signal is lost. (This data is also output to external equipment.)

1. Press the [MENU] key to display the main menu.
2. Choose OTHERS and then press the [ENT] key.

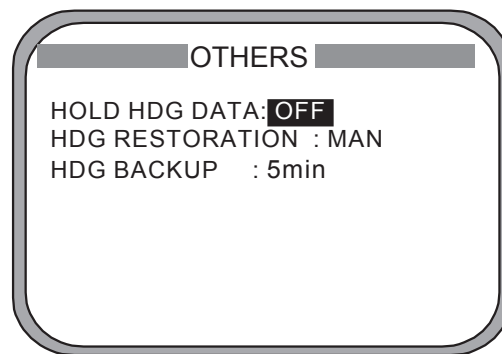

Others menu

3. HOLD HDG DATA is selected; press the [ENT] key.



4. Choose ON or OFF as appropriate. When ON is selected, "BCK" appears on displays that show heading.
5. Press the [ENT] key.
6. HDG RESTORATION is selected; press the [ENT] key.



HDG RESTORATION options

7. Use the Omnipad to choose MAN or AUTO as appropriate and then press the [ENT] key.
8. HDG BACKUP is selected; press the [ENT] key.
9. Choose 1, 2, 3, 4 or 5 minutes as appropriate.
10. Press the [ENT] key followed by the [DISP] key to close the menu.

2.12 TRIP Menu

The TRIP menu functions to

- Choose the indication to show on the SOG/STW display
- Choose source of distance run
- Reset distance run to zero
- Smooth the tide drift indication
- Enter smoothing for rate of turn and display range scale

1. Press the [MENU] key to display the main menu.
2. Choose TRIP MENU and then press the [ENT] key.

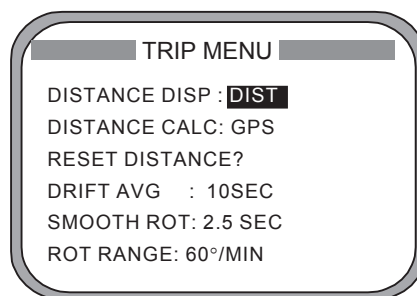

TRIP menu

3. Choose DISTANCE DISP and then press the [ENT] key.
4. Choose what to display on the Speed display; distance run (DIST) or tide direction and speed (DRIFT). Press the [ENT] key.
5. Choose DISTANCE CALC and then press the [ENT] key.
6. Choose the source for distance run; GPS, VLW (distance traveled through water) or VBW (Dual ground/water speed). (VLW requires DS-80 type Doppler speed log and VBW requires Current indicator or Doppler speed log.) Press the [ENT] key.
7. Choose DRIFT AVG. and then press the [ENT] key.
8. If tide current and speed data is unstable, enter a smoothing figure to stabilize the data. The higher the figure the more smoothed the data. A setting between 0 (no smoothing) and 9999 (seconds) is available.
9. Choose SMOOTH ROT and then press the [ENT] key.
10. Use the Omnipad to enter rate of turn smoothing rate. Choose location with ◀ or ▶; change value with ▲ or ▼. The setting range is 0.1 to 30.0 (seconds).
11. Press the [ENT] key.
12. Choose ROT RANGE and then press the [ENT] key.
13. Choose the range of the ROT graph from among 30, 60 and 90 (degree/min.) and then press the [ENT] key.
14. Press the [DISP] key to close the menu.

2.13 Resetting Distance Run

The distance run may be reset to zero as below when the source of distance run is GPS or VBW.

1. Press the [MENU] key to display the main menu.
2. Choose TRIP MENU and then press the [ENT] key.
3. Choose RESET DISTANCE and then press the [ENT] key.

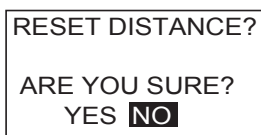

RESET DISTANCE prompt

4. Choose YES and then press the [ENT] key.
5. Press the [DISP] key to close the menu.

2.14 Choosing External Heading Source for Backup

Choose the source of heading data as below.

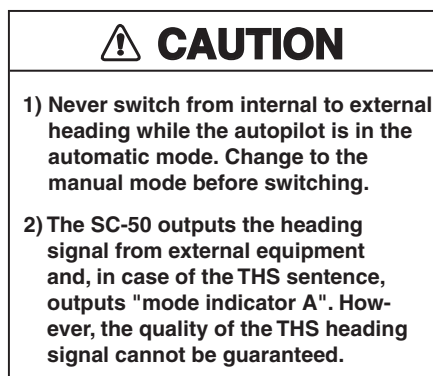

1. Press the [HDG SETUP] key.

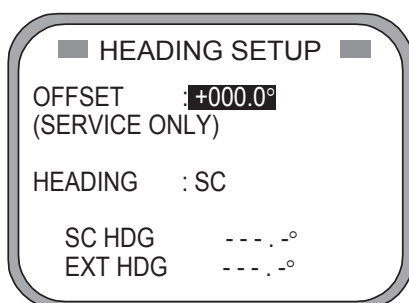

- OFFSET : Heading offset. See service manual for instructions. "SERVICE ONLY" means heading offset shown for display only.
- HEADING : Select heading source. Choose SC for normal use. If a gyrocompass is connected for primary means, leaving this equipment as backup, choose EXT.
- SC HDG : Bow heading. Includes offset.
- EXT HDG : Heading fed from external equipment.

Heading setup menu

2. "HEADING" is selected; press the [ENT] key.
3. Choose SC, EXT or AUTO as appropriate.
 - SC: Position fix by own GPS sensor. Normally choose SC.
 - EXT: Position fix by an external heading sensor. If own GPS sensor is not working and a heading sensor such as a gyrocompass is available, choose EXT.



2. OPERATION

AUTO: When connecting an external heading sensor, the heading source automatically changes to the external heading if the setting time exceeds the setting in HDG BACKUP (see section 2.11). When own GPS sensor is restored, the heading source automatically changes to the internal heading.

Note: After choosing AUTO, reset the power to affect the setting.

4. Press the [ENT] key.
5. Press the [DISP] key to close the menu.

3 MAINTENANCE, TROUBLESHOOTING

 WARNING	
	ELECTRICAL SHOCK HAZARD Do not open the equipment. Only qualified personnel should work inside the equipment.

NOTICE
Do not apply paint, anti-corrosive sealant or contact spray to coating or plastic parts of the equipment. Those items contain organic solvents that can damage coating and plastic parts, especially plastic connectors.

3.1 Preventive Maintenance

Regular maintenance is important for good performance. A maintenance program should be established and should include the following points.

- Check connectors and ground terminal on the processor unit and display unit for tightness.
- Check ground terminal for rust. Clean or replace as necessary.
- Check for water leakage in the antenna cable. Replace the cable if there are signs of water leakage.
- Remove dust and dirt from the display unit and processor unit with a dry, soft cloth. For the LCD, wipe it carefully to prevent scratching, using tissue paper and an LCD cleaner. To remove stubborn dirt, use an LCD cleaner, wiping slowly with tissue paper so as to dissolve the dirt. Change paper frequently so the dirt will not scratch the LCD. Do not use chemical cleaners for cleaning - they can remove paint and markings.

3.2 Troubleshooting

This section provides basic troubleshooting procedures which the user may follow to restore normal operation.

Troubleshooting

Symptom	Cause	Remedy
Cannot turn on the power.	Power cable on the processor unit	Firmly connect the power cable
	Power supply failure	Check the power supply.
	Blown fuse	Have a qualified technician check the fuse.
Heading indication changes randomly when ship is at anchor or does not change when ship moves.	Sensor trouble	Run the diagnostic test ² to determine cause.
Heading output from SC-50 does not appear on external equipment.	Connection between SC-50 and external equipment has loosened.	Firmly fasten the connector.
	Sensor trouble	Run the diagnostic test ¹ to determine the cause.

If large heading error occurs or heading indication is frequently interrupted, contact your dealer for advice.

3.3 Diagnostics

Diagnostic test1

The diagnostic test1 checks the equipment for proper operation.

Note: Heading is not output during the diagnostic test, and this is communicated with an appropriate message. After completing the diagnostic test, turn the power off and on to update heading data.

1. Press the [MENU] key to open the menu.
2. Choose SYS SETUP and then press the [ENT] key.
3. Choose TEST? and then press the [ENT] key.

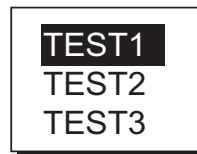

Test menu options

4. Confirm that TEST1 is selected and then press the [ENT] key.

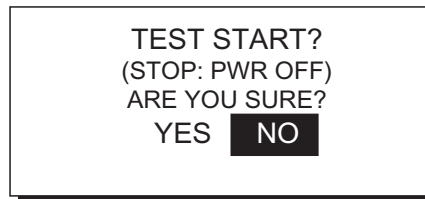

Test start prompt

5. Press ◀ to choose YES and then press the [ENT] key. The test proceeds in the sequence shown on the next page.

Note: The output port test (see next page) is intended for the service technician, using a special test connector. If TEST1 is conducted without the test connector, disconnect the DATA IN connector from the processor unit.

3. MAINTENANCE, TROUBLESHOOTING

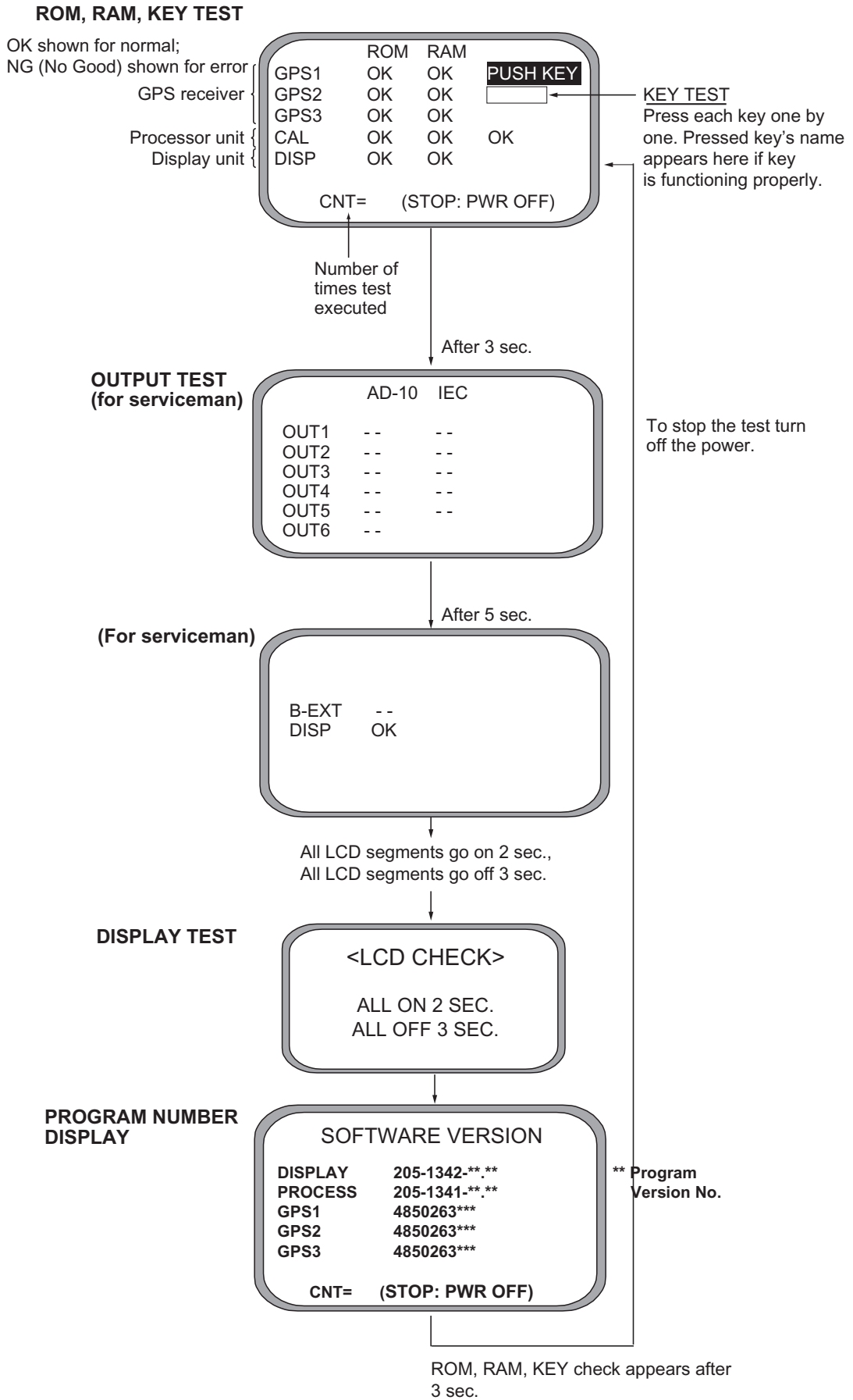

Diagnostic test sequence

6. Turn off the processor unit to quit the diagnostic test1.

Diagnostic test2

If the heading indication changes randomly when ship is at anchor or does not change when the ship moves, run the test2 following the procedure below, with the ship at anchor and satellite signal received.

Note: Heading is not output during the diagnostic test, and this is communicated with an appropriate message. After completing the diagnostic test, turn the power off and on to update heading data.

1. Press the [MENU] key to open the menu.
2. Choose SYS SETUP and then press the [ENT] key.
3. Choose TEST? and then press the [ENT] key.

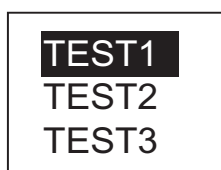

Test menu options

4. Choose TEST2 and then press the [ENT] key.

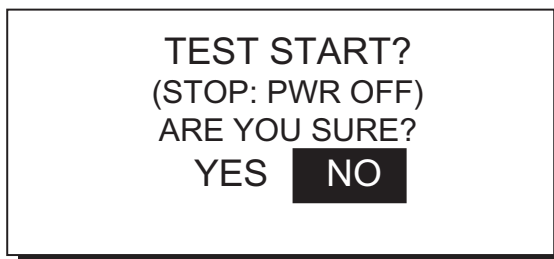

Test start prompt

5. Press ◀ to choose YES and then press the [ENT] key.
6. Press the [ENT] key twice. Rate and angle values are 0.0°. If the values increase or decrease markedly (with ship at anchor), suspect rate sensor trouble. Contact your dealer to request service.

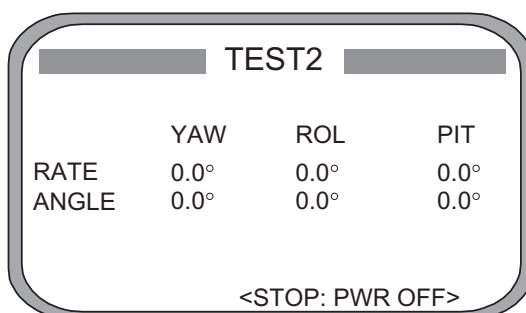

TEST2 display

7. Turn off the processor unit to quit the diagnostic test2.

Diagnostic test3

This test checks the buzzer signal/contact for proper operation.

1. Press the [MENU] key to open the menu.
2. Choose SYS SETUP and then press the [ENT] key.
3. Choose TEST? and then press the [ENT] key.

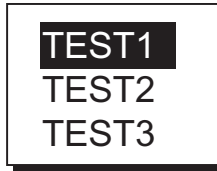

Test menu options

4. Choose TEST3 and then press the [ENT] key.

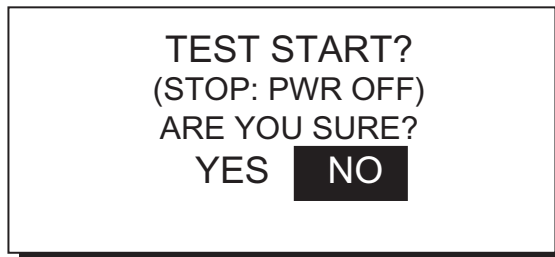

Test start prompt

6. Press ◀ to choose YES and then press the [ENT] key.

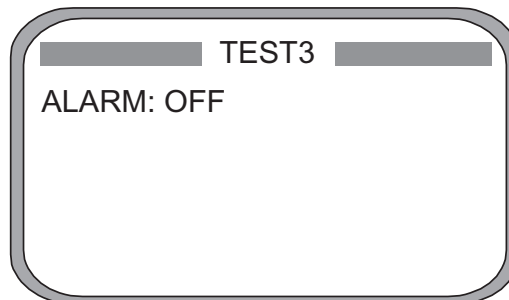

TEST3 menu

7. Press the [ENT] key.



ALARM options

8. Choose OFF or ON as appropriate and then press the [ENT] key.
OFF: Buzzer sound goes off, alarm contact signal is closed.
ON: The buzzer sounds and the alarm contact is open.
9. To quit the test, turn off the processor unit.

3.4 Program Number

You may display the program number as follows:

1. Press the [MENU] key to open the menu.
2. Choose SOFT VER. and then press the [ENT] key.

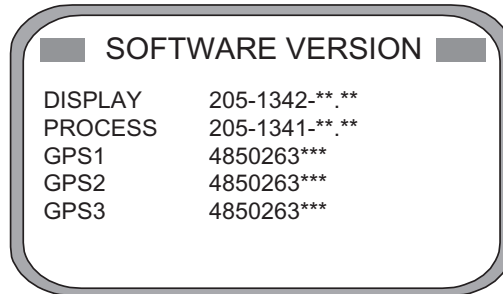

** = Program version no.

Program number display

3. Press the [DISP] key to close the program version no. display.

3.5 Clearing Data

You may clear GPS data and system data all at once or individually as follows:

1. Press the [MENU] key to open the menu.
2. Choose ERASE and then press the [ENT] key.

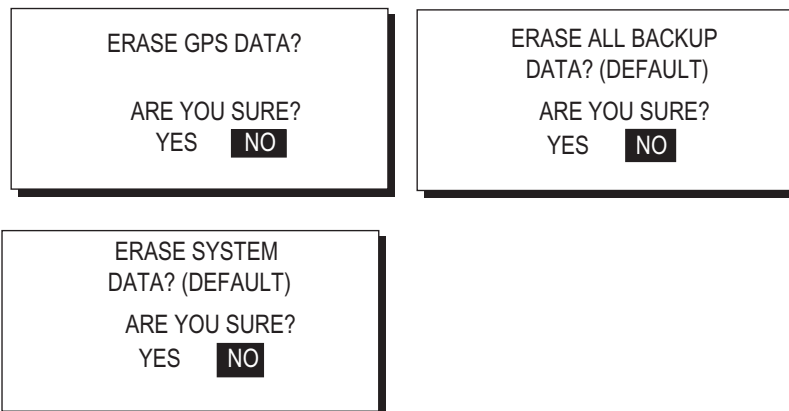

Prompts for erasure of data

3. Choose GPS DATA?, SYSTEM DATA? or ALL BACKUP DATA? (clears GPS and SYSTEM data) as appropriate. One of the following displays appears depending on your selection.
4. Press ◀ to choose YES and then press the [ENT] key to erase. After data is erased the message "Completed erasing. Turn off the unit." is displayed.

Note: MOUNTING, DIRECTION and LANGUAGE in the INST menu, HDG RESTORATION and HDG BACKUP in the OTHERS menu and OFFSET in the HEADING SETUP menu are not cleared.

5. Turn off and on the power.

3.6 Replacement of Battery

The processor unit has a battery which stores data when the power is turned off. When the battery voltage is low, the message “BATTERY!” appears on the display. Have a qualified technician replace the battery, following the procedure below. The life of the battery is 3-5 years.

Battery Location	Type	Code No.
Processor Unit	CR2450-F2ST2L	000-144-941

1. Press the [MENU] key to open the menu.
2. Choose SYS SETUP and then press the [ENT] key.
3. Choose “EXCHANGE BATTERY?” and then press the [ENT] key.

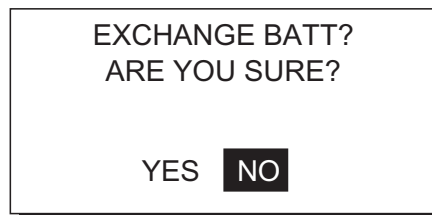

Prompt for exchanging battery

4. Press ◀ to choose YES and then press the [ENT] key. The following message appears.

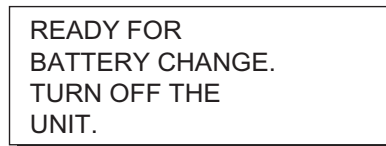

Prompt for turning off the power

5. At this time the contents of the RAM are temporarily moved to the flash memory. Turn off the power.
6. Have a qualified technician replace the battery.

Note: If the equipped will not be used for a long period of time, save data by following the above procedure. This will prevent loss of data even if the battery dies.

3.7 Replacement of Fuse

The 3 A fuse on the POWER Board inside the processor unit protects the equipment from overcurrent and reverse polarity of the power supply. If the fuse blows, have a qualified technician check the fuse.



3.8 Error Messages

The alarm sounds for equipment error and is accompanied by a flashing popup indication. Press any key to silence the alarm and erase the popup. Find the cause for the alarm(s) as follows:

1. Press the [MENU] key to open the menu.
2. Choose MESSAGES and then press the [ENT] key. The latest alarm is at the top of the list.

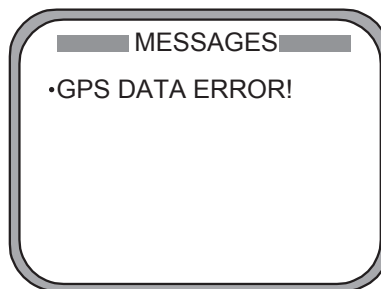

Message display

3. Press the [DISP] key to close the menu.

Error messages

Error Message	Meaning	Remedy
ABORTING!	GPS heading error continues for one minute. For example, satellite cannot be acquired because of unfavorable environment.	Check for obstruction.
ABORTING CALC!	GPS signal lost for one minute.	Press any key to try to restore normal operation.
BACKUP ERROR!(DISP)	Corrupted backup data found in display unit at power on.	Default settings are automatically restored.
BACKUP ERROR!(PRCSSR)	Corrupted backup data found at processor unit at power on.	Default settings are automatically restored.

(Continued on next page)

3. MAINTENANCE, TROUBLESHOOTING

Error messages (con't from previous page)

Error Message	Meaning	Remedy
BATTERY ALM!	Voltage of battery in processor unit is low.	Have battery replaced at earliest convenience.
DATA ERR!	GPS data (from the GPS receiver in the processor unit) is lost for one minute. Heading output is stopped and the heading indication shows "--".	Check GPS receiver.
DGPS ERROR!	DGPS data (from external DGPS receiver) is lost for one minute.	Ship may not be within DPGS service area.
GPS DATA ERROR!	GPS data (from internal GPS receiver) is lost for one minute. Heading output is stopped and the heading indication shows "--".	Conduct diagnostic test1 and check if NG appears for results for GPS receivers GPS1, GPS2 and GPS3.
GPS NO FIX!	No GPS data.	Check antenna cable.
HDG ERROR!	Heading error	Request service.
NO HEADING OUTPUT!	GPS heading error continues for five* minutes. In this case the heading indication shows "--" and heading output is stopped. * = default setting. May be changed by "backup" setting.	Press any key to try to restore normal operation.
RAM ERROR!	RAM problem	Request service.
RATE ERROR(YAW)!	Data output stopped.	Request service.
RATE ERROR(ROLL)!	Data output stopped.	Request service.
RATE ERROR(PITCH)!	Data output stopped.	Request service.
COMMUNICATION ERR!	Communication between display unit and processor has been interrupted.	Request service.
WAAS ERROR	WAAS data lost for one minute.	Request service.
ROM ERROR!	ROM problem	Request service.

*: Alarm port goes open when message appears.

APPENDIX

1. Menu Tree

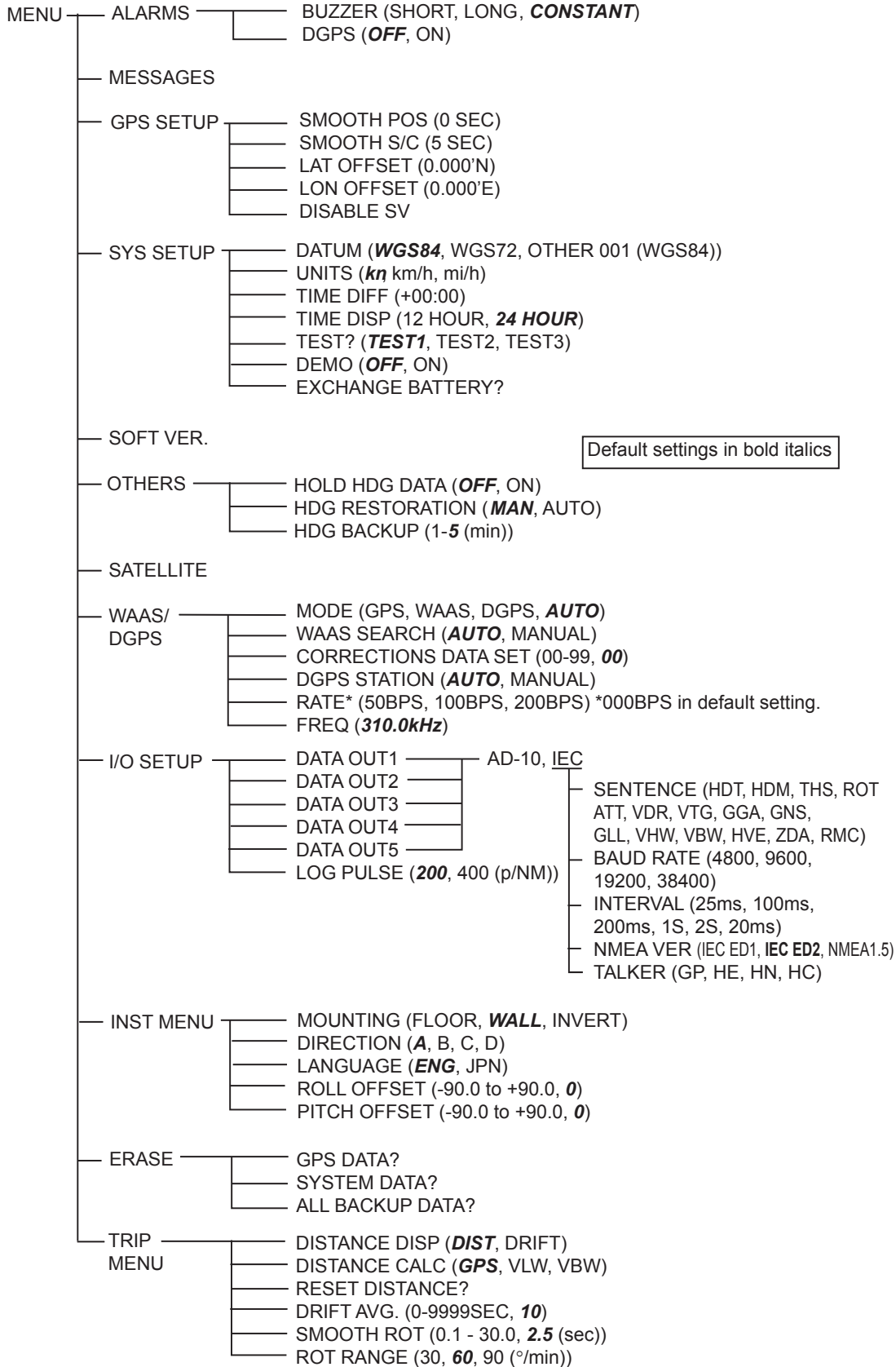

2. Digital Interface

Output sentences of channel 1

DATA OUT1-5: HDT, HDM, THS, ROT, VTG, GGA, GLL, GNS, ZDA, VHW, VBW, VDR
DATA OUT 6: AD-10

Transmission interval

HDT, HDM, THS, ROT: 100 ms

VTG, GGA, GLL, GNS, ZDA, VHW, VBW, VDR: 1 s

For details see page 2-12.

Load requirement as listener

Isolation: Optocoupler

Input Impedance: 220 ohms

Max. Voltage: $\pm 15V$

Threshold: 4 mA

Data transmission

Data is transmitted in serial asynchronous form in accordance with the standard referenced in 2.1 of IEC 61162-1. The first bit is a start bit and is followed by data bits, least-significant-bit as illustrated below.

The following parameters are used:

Baud rate: 4800

Data bits: 8 (D7 = 0), parity none

Stop bit: 1

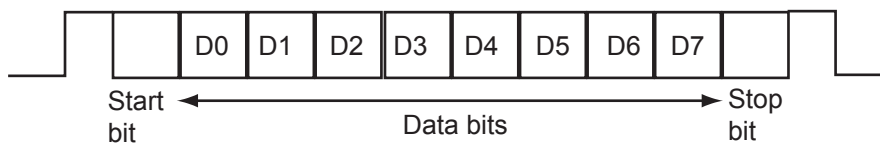

Schematic diagrams

Data IN

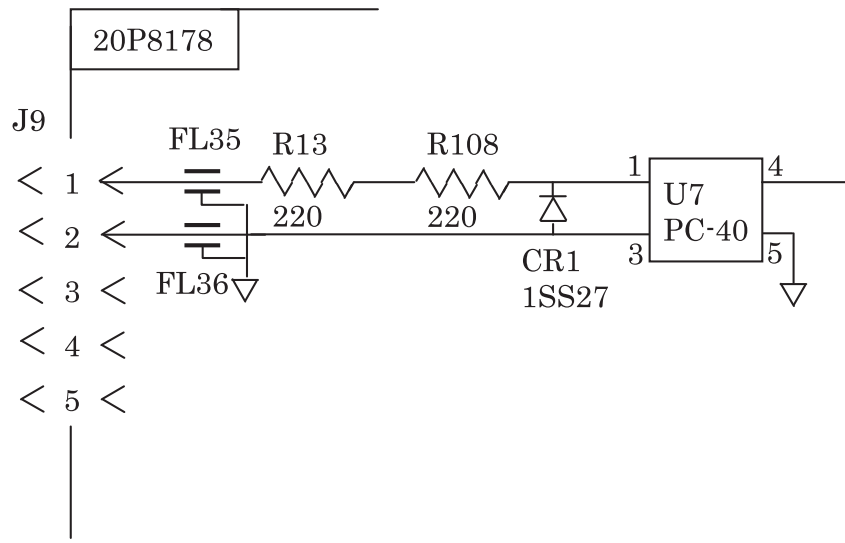

Load requirements

Isolation: Optocoupler

Input Impedance: 440 ohm

Max. voltage: $\pm 15V$

Data Out 1-6

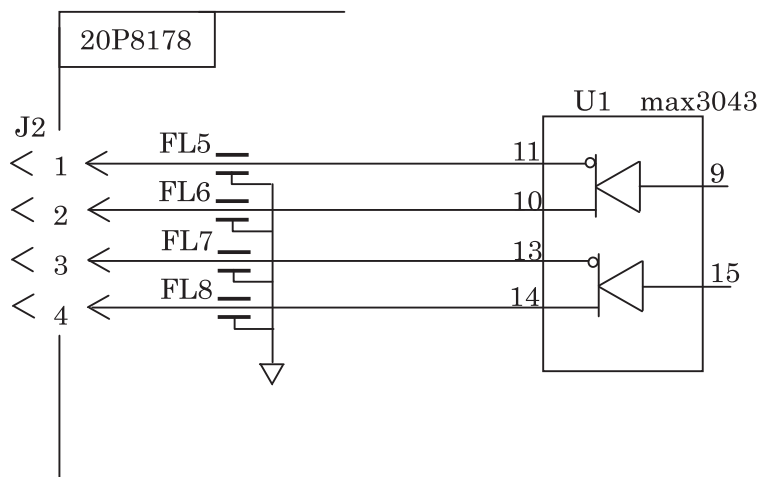

Output drive capability

Max : 10mA

Data sentences

GGA - Global positioning system (GPS) fix data

Time, position and fix related data for a GPS receiver.

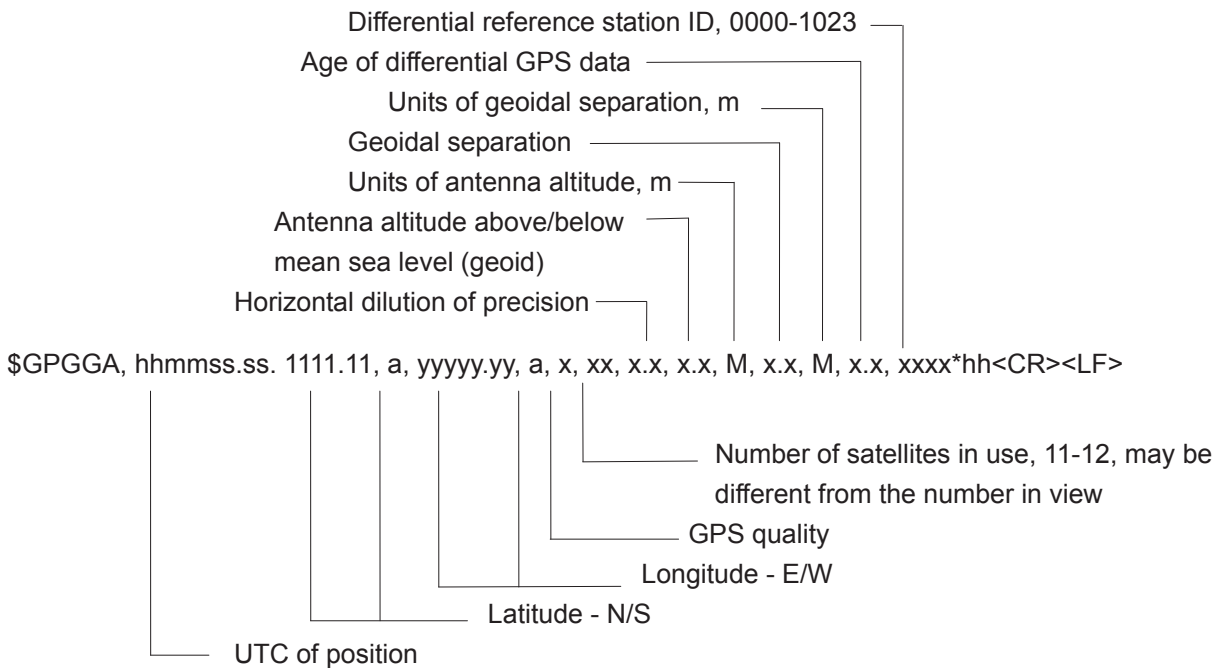

Note: GPS quality is as follows;

ED1: 0 (No fix), 1 (GPS fix)

ED2: 0 (No fix), 1 (GPS fix), 2 (DGPS fix), 8 (simulator mode)

GLL - Geographic position - latitude/longitude

Latitude and longitude of present vessel position, time of position fix and status.

`$--GPGLL, 1111.11, a, yyyy.yy, a, hhmmss.ss, A, p*hh<CR><LF>`

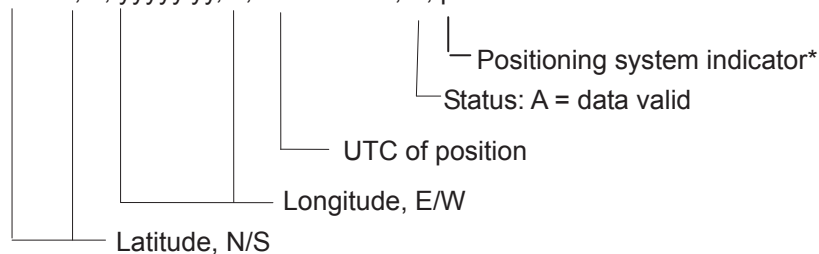

*A = Autonomous, D = Differential, E = estimated (dead reckoning), M = Manual input, S = Simulator, N = Data not valid. The Mode indicator field supplements the Status field. The Status field shall be set to V=invalid for all values of Operating Mode except for A=Autonomous and D=Differential. The positioning system Mode indicator and Status field shall not be null fields.

Note: Position system indicator with IEC ED2 only.

GNS - GNNS fix data

\$--GNS,hhmmss.ss,llll.lll,a,yyyyy.yyy,a,c--c,xx,x.x,x.x,x.x,x.x,x.x*x*hh<CR><LF>

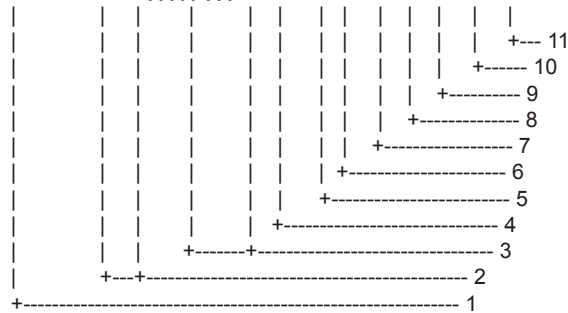

1. UTC of position
2. Latitude, N/S
3. Longitude, E/W
4. Mode indicator
5. Total number of satellite in use,00-99
6. HDOP
7. Antenna altitude, metres, re:mean-sea-level(geoid)
8. Geoidal separation
9. Age of differential data
10. Differential reference station ID
11. Checksum

HDM- Heading – magnetic

This sentence is not used in the current version of NMEA and IEC 61162. Some boaters may want the GPS compass to indicate the magnetic heading when the boat is only fitted with a magnetic compass. HDG is calculated by adding a geomagnetic variation to HDT.

\$--HDM, x.x, M *hh<CR><LF>

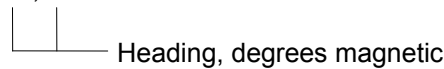

HDT - Heading - true

True heading in degrees obtained by processing RF cycle in the GPS carrier frequency.

\$--HDT, x.x, T*hh<CR><LF>

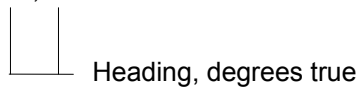

THS – True heading and status

Note: This sentence replaces the deprecated sentence HDT.

Actual vessel heading in degrees true produced by any device or system producing true heading. This sentence includes a “mode indicator” field providing critical safety related information about the heading data, and replaces the deprecated HDT sentence.

\$--THS,x.x,a*hh<CR><LF>

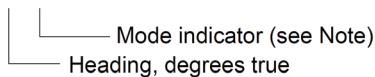

NOTE Mode indicator. This field should not be null.

- A = Autonomous
- E = Estimated (dead reckoning)
- M = Manual input
- S = Simulator mode
- V = Data not valid (including standby)

RMC – Recommended minimum specific GNSS data

\$GPRMC,hhmmss.ss,A,llll.ll,a,yyyy.yy,a,x.x,x.x,ddmmyy,x.x,a,*hh<CR><LF>
 1 2 3 4 5 6 7 8 9 10 11 12

1. UTC of position fix (000000 - 235959)
2. Status (A=data valid, V=navigation receiver warning)
3. Latitude (0.0000 - 9000.0000)
4. N/S
5. Longitude (0.0000 - 18000.0000)
6. E/W
7. Speed over ground, knots (0.0 - 9999.9)
8. Course over ground, degrees true (0.0 - 359.0)
9. Date (010100 - 311299)
10. Magnetic variation, degrees E/W (0.0 - 180.0/NULL)
11. E/W
12. Mode indicator (A=Autonomous D=Differential mode E=Estimated (dead reckoning mode)
 M=Manual input mode S=Simulator N: Data not valid)

ROT – Rate of turn

ROT derived from a changing rate of GPS compass heading.

\$--ROT, x.x, A*hh<CR><LF>

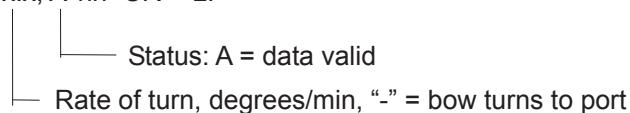

VBW - Dual ground/water speed

\$**VBW,x.x,x.x,x.x,x.x,x.x,x.x,x.x,x.x,*hh<CR><LF>
 1 2 3 4 5 6 7 8 9 10

1. Longitudinal water speed, knots (-9999.99 - 9999.99)
2. Transverse water speed, knots (-9999.99 - 9999.99)
3. Status: water speed, A=data valid V=data invalid
4. Longitudinal ground speed, knots (-9999.99 - 9999.99)
5. Transverse ground speed, knots (-9999.99 - 9999.99)
6. Status: ground speed, A=data valid V=data invalid
7. Stern transverse water speed, knots (-9999.99 - 9999.99)
8. Status: stern water speed, A=data valid V=data invalid
9. Stern transverse ground speed, knots (-9999.99 - 9999.99)
10. Status: stern ground speed, A=data valid V=data invalid

Note: #7 to #10 with IEC ED2 only.

VDR - Set and drift

\$**VDR,x.x,T,x.x,M,x.x,N,*hh <CR><LF>
 1 2 3 4 5 6

1. Direction, degrees (0.0 - 360.0)
2. T=True (fixed)
3. Direction, degrees (0.0 - 360.0)
4. M=Magnetic (fixed)
5. Current speed (0 - 99.99)
6. N=Knots (fixed)

VHW - Water speed and heading

The compass heading to which the vessel points and the speed of the vessel relative to the water.

\$GPVHW,x.x,T,x.x,M,x.x,N,x.x,K,*hh <CR><LF>

1 2 3 4 5 6 7 8

1. Heading, degrees (0.0 - 359.9, NULL)
2. T=True (fixed)
3. Heading, degrees (0.0 - 359.9, NULL)
4. M=Magnetic (fixed)
5. Speed, knots (0.0 - 9999.9)
6. N=Knots (fixed)
7. Speed, knots (0.0 - 9999.9)
8. K=km/hr (fixed)

VLW - Distance travelled through the water

The distance travelled, relative to the water.

\$**VLW,x.x,N,x.x,N,x.x,N,x.x,N,*hh<CR><LF>

1 2 3 4 5 6 7 8

1. Total cumulative water distance (0.0 - 999999.999)
2. N=Nautical miles
3. Water distance since reset (0.000 - 999999.999)
4. N=Nautical miles
5. Total cumulative ground distance (no use)
6. N=Nautical miles (no use)
7. Ground distance since reset (no use)
8. N=Nautical miles (no use)

VTG - Course over ground and ground speed

COG and SOG obtained by processing the GPS signals.

\$GPVTG,x.x,T,x.x,M,x.x,N,x.x,K,a,*hh <CR><LF>

1 2 3 4 5 6 7 8 9

1. Course over ground, degrees (0.0 - 359.9)
2. T=True (fixed)
3. Course over ground, degrees (0.0 - 359.9)
4. M=Magnetic (fixed)
5. Speed over ground, knots (0.00-9999.9)
6. N=Knots (fixed)
7. Speed over ground (0.00 - 9999.9)
8. K=km/h (fixed)
9. Mode indicator (A=Autonomous, D=Differential E = Estimated (dead reckoning)
M=Manual input S=Simulator N=Data not valid)

Note: Position system indicator with IEC ED2 only.

ZDA - Time and date

UTC, day, month, year and local time zone.

\$GPZDA,hhmmss.ss,xx,xx,xxxx,xx,xx<CR><LF>

1 2 3 4 5 6

1. UTC (000000 - 235959)...See NOTE2
2. Day (01 - 31)
3. Month (01 -12)
4. Year (UTC, 0000 - 9999)
5. Local zone, hours (-13 to ±13)...See NOTE1
6. Local zone, minutes (00 to ±59)

NOTE1 - Zone description if the number of whole hours added to local time to obtain GMT. Zone description is negative for east longitudes.

NOTE2 – Decimal point and decimal fraction are not output.

3. Input/Output Ports

Port Label	Terminal Name	I/O	Signal	Remarks
DATA OUT1	WAGO 231-304/026-000	O	Heading, Speed, Course, Position, and Time	IEC61162(NMEA0183) or AD-10 format (software)
DATA OUT2	WAGO 231-304/026-000	O		IEC61162-1 (NMEA0183) Ver1.5, 2.0 IEC61162-2
DATA OUT3	WAGO 231-304/026-000	O		Talker: GP, HE, HN,HC (HDT, HDM, THS, ROT selectable; other sent. GP only)
DATA OUT4	WAGO 231-304/026-000	O		Speed: 4800, 9600, 19200, 38400 bps IEC61162 sentences: HDT, HDM, THS, ROT, VTG, GGA, GLL, GNS, ZDA, VHW, VBW, VDR, RMC (on/off by menu)
DATA OUT5	WAGO 231-304/026-000	O		IEC61162 (NMEA0183) : sentence output interval : HDT, HDM, THS, ROT : (25ms, 100ms, 200ms, 1s, 2s, 20ms, selectable), VTG, GGA, GLL, GNS, ZDA, VHW, VBW, VDR, RMC : (1s, 2s, selectable)

(Continued on next page)

(Continued from previous page)

Port Label	Terminal Name	I/O	Signal	Remarks
DATA OUT6	WAGO 231-304/026-000	O	Heading	AD-10 only AD-10 output interval: 25ms
LOG/ ALARM	WAGO 231-306/026-000	O	LOG Signal	200 pulse/NM or 400 pulse/NM (software), 0.5A max.
			HDG alarm	Heading alarm, 0.5A max, normal close
DATA IN	WAGO 231-305/026-000	O	Heading	Heading data in either AD-10 or IEC61162(NMEA0183) format (4800, 9600, 19200, 38400bps) is automatically received. Priority of IEC61162(NMEA0183) sentence is HDT>HDG>HDM. The signal is selected through the menu during the period of internal heading sensor failure. VBW/VHW may be input from a current indicator.

4. Parts List and Parts Location

This equipment contains complex modules in which fault diagnosis and repair down to component level are not practical (IMO A.694(17)/8.3.1. Only some discrete components are used. FURUNO Electric Co., Ltd. believes identifying these components is of no value for shipboard maintenance; therefore, they are not listed in the manual. Major modules can be located on the parts location photo on this page.

FURUNO	Model	SC-50/110		
	Unit	SC-502		
	ELECTRICAL PARTS LIST	DISPLAY UNIT		Page
	Ref.Dwg.			
	Blk.No.			
SYMBOL	TYPE	CODE No.	REMARKS	SHIPPABLE ASSEMBLY
	PRINTED CIRCUIT BOARD			
	20P8189, CPU			

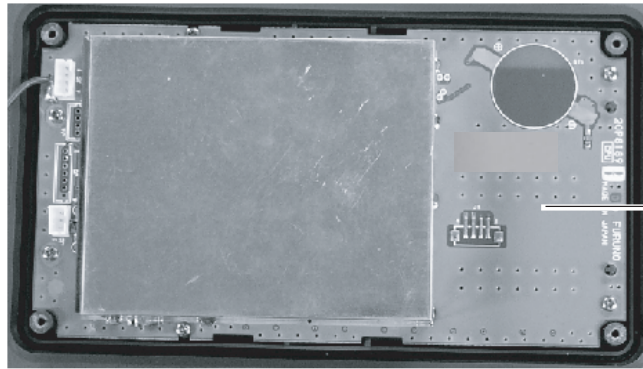

CPU Board (20P8189)

Display Unit, cover opened

FURUNO	Model	SC-50		
	Unit	SC-501		
	ELECTRICAL PARTS LIST	PROCESSOR UNIT		Page
	Ref.Dwg.			
	Blk.No.			
SYMBOL	TYPE	CODE No.	REMARKS	SHIPPABLE ASSEMBLY
	PRINTED CIRCUIT BOARD			
	20P8178, MAIN 20P8181, PWR			

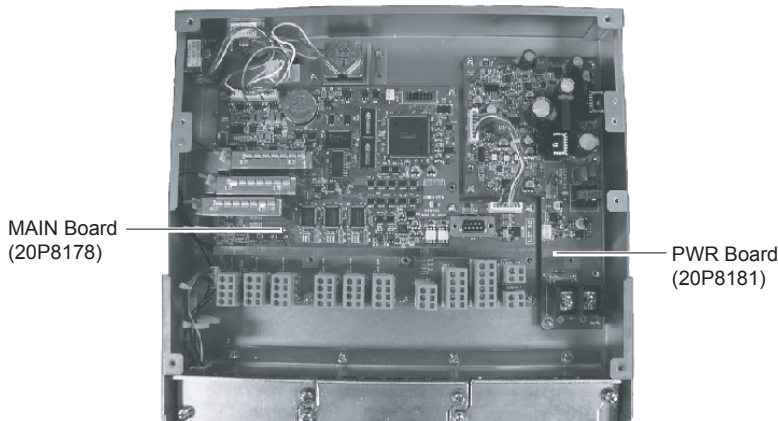

MAIN Board (20P8178)

PWR Board (20P8181)

Processor Unit, cover removed

5. Geodetic Chart Codes

001 :	WGS84		
002 :	WGS72		
003 :	TOKYO		
004 :	NORTH AMERICAN 1927	: Mean Vallue (Japan, Korea, and Okinawa)	
005 :	EUROPEAN 1950	: Mean Vallue (CONUS)	
006 :	AUSTRALIAN GEODETIC 1984	: Mean Vallue	
007 :	ADINDAN	: Australla and Tasmania Island	
008 :		: Mean Value(Ethiopia and Sudan)	
009 :		: Ethiopia	
010 :		: Mall	
011 :		: Senegal	
012 :	AFG	: Sudan	
013 :	AIN EL ABD 1970	: Somalla	
014 :	ANNA 1 ASTRO 1965	: Bahrain Island	
015 :	ARC 1950	: Cocos Island	
016 :		: Mean Value	
017 :		: Bostswana	
018 :		: Lesotho	
019 :		: Malawi	
020 :		: Swaziland	
021 :		: Zaire	
022 :		: Zambia	
023 :	ARC 1960	: Zimbabwe	
024 :		: Mean Value (Kanya, Tanzania)	
025 :		: Kenya	
026 :	ASCENSION ISLAND 1958	: Tanzania	
027 :	ASTRO BEACON "E"	: Ascension Island	
028 :	ASTRO B4 SOR. ATOLL	: Iwo Jima Island	
029 :	ASTRO POS 71/4	: Tem Island	
030 :	ASTRONOMIC STATION 1952	: St. Helena Island	
031 :	AUSTRALIAN GEODETIC 1966	: Marcus Island	
032 :	BELLEVUE (IGN)	: Australla and Tasmania Island	
033 :	BERMUDA 1957	: Efate and Erromango Islands	
034 :	BOGOTA OBSERVATORY	: Bermuda Islands	
035 :	CAMPO INCHAUSPE	: Colombla	
036 :	CANTON ISLAND 1966	: Argentina	
037 :	CAPE	: Phoenix Islands	
038 :	CAPE CANAVERAL	: South Africa	
039 :	CARTHAGE	: Mean Value (Florida and Bahama Islands)	
040 :	CHATHAM 1971	: Tunisia	
041 :	CHUAASTRO	: Chatham Island (New Zealand)	
042 :	CORREGO ALEGRE	: Paraguay	
043 :	DJAKARTA (BATAVIA)	: Brazil	
044 :	DOS 1968	: Sumatra Island (Indonesia)	
045 :	EASTER ISLAND 1967	: Gizo Island (New Georgla Island)	
046 :	EUROPEAN 1950 (Cont'd)	: Easter Island	
047 :		: Western Europe	
048 :		: Cyprus	
049 :		: Egypt	
050 :		: England, Scotland, Channel, and Shetland Islands	
051 :		: England,Ireland, Scotland, and Shetland Islands	
052 :		: Greece	
053 :		: Iran	
054 :		: Italy • • Sardinla	
055 :		: Italy • • Sicily	
056 :		: Norway and Finland	
057 :	EUROPEAN 1979	: Portugal and Spain	
058 :	GANDAJIKA BASE	: Mean Value	
059 :	GEODETIC DATUM 1949	: Republic of Maldives	
060 :	GUAM 1963	: New Zealand	
061 :	GUX 1 ASTRO	: Guam Island	
062 :	HJORSSEY 1955	: Guadalcanal Island	
063 :	HONG KONG 1963	: Iceland	
064 :	INDIAN	: Hong kong	
065 :		: Thailand and Vletnam	
066 :	IRELAND 1956	: Bangladesh, India, and Nepal	
067 :	ISTS 073 ASTRO 1969	: Ireland	
068 :	JHONSTON ISLAND 1961	: Diego Garcia	
069 :	KANDAWALA	: Jhonston Island	
070 :	KERGUELEN ISLAND	: Sri Lanka	
071 :	KERTAU 1948	: Kerguelen Island	
072 :	LA REUNION	: West Malaysia and Singapore	
073 :	L.C. 5 ASTRO	: Mascarene Island	
074 :	LIBERIA 1964	: Cayman Brac Island	
075 :	LUZON	: Liberia	
076 :		: Philippines (Exciuding Mindanao Island)	
077 :	MAHE 1971	: Mindanao Island	
078 :	MARCO ASTRO	: Mahe Island	
079 :	MASSAWA	: Salvage Islands	
080 :	MERCHICH	: Eritrea (Ethlopia)	
081 :	MIDWAY ASTRO 1961	: Morocco	
082 :	MINNA	: Midway Island	
083 :	NAHRWAN	: Nigeria	
084 :		: Masirah Island(Oman)	
085 :		: United Arab Emirates	
086 :	NAMIBIA	: Saudi Arabia	
		: Namibla	
087 :	MAPARIMA, BWI		: Trinidad and Tobago
088 :	NORTH AMERICAN 1927		: Western United States
089 :			: Eastern United States
090 :			: Alaska
091 :			: Bahamas (Excluding San Saivador Island)
092 :			: Bahamas • • San Saivador Island
093 :			: Canada (Including Newfoundland Island)
094 :			: Alberta and British Columbia
095 :			: East Canada
096 :			: Manitoba and Ontario
097 :			: Nothwest Territories and Saskatchewan
098 :			: Yukon
099 :			: Canal Zone
100 :			: Caribbean
101 :			: Central America
102 :			: Cuba
103 :			: Greenland
104 :			: Mexico
105 :	NORTH AMERICAN 1983		: Alaska
106 :			: Canada
107 :			: CONUS
108 :			: Mexico, Central America
109 :	OBSERVATORIO 1966		: Corvo and Flores Islands (Azores)
110 :	OLD EGYPTIAN 1930		: Egypt
111 :	OLD HAWAIIAN		: Mean Value
112 :			: Hawaii
113 :			: Kaula
114 :			: Maui
115 :			: Oahu
116 :	OMAN		: Oman
117 :	ORDNANCE SURVEY OF GREAT BRITAIN 1936	: Mean Value	
118 :			: England
119 :			: England, Isie of Man, and Wales
120 :			: Scotland and Shetland Islands
121 :			: Wales
122 :	PICO DE LAS NIVIES		: Canary Islands
123 :	PITCAIRN ASTRO 1967		: Pitcaim Island
124 :	PROVISIONAL SOUTH CHILEAN 1963		: South Chile (near 53° s)
125 :	PROVISIONAL SOUTH AMERICAN 1956		: Mean Value
126 :			: Bolivia
127 :			: Chile • • Northern Chie (near 19° s)
128 :			: Chile • • Southern Chile (near 43° s)
129 :			: Colombia
130 :			: Ecuador
131 :			: Guyana
132 :			: Peru
133 :			: Venezuela
134 :	PUERTO RICO		: Puerto Rico and Virgin Islands
135 :	QATAR NATIONAL		: Qatar
136 :	QORNOQ		: South Greenland
137 :	ROME 1940		: Sardinia Islands
138 :	SANTNA BRAZ		: Sao Maguel, Santa Maria Islands (Azores)
139 :	SANTO (DOS)		: Espirito Santo Island
140 :	SAPPER HILL 1943		: East Faikland Island
141 :	SOUTH AMERICAN 1969		: Mean Value
142 :			: Argentina
143 :			: Bolivia
144 :			: Brazil
145 :			: Chile
146 :			: Colombia
147 :			: Ecuador
148 :			: Guyana
149 :			: Paraguay
150 :			: Peru
151 :			: Trinidad and Tobago
152 :			: Venezuela
153 :	SOUTH ASIA		: Singapore
154 :	SOUTHEAST BASE		: Porto Santo and Medeira Islands
155 :	SOUTHWEST BASE		: Falal, Graciosa,Pico, Sao Jorge, and Terceira Islands
156 :	TIMBALAI 1948		: Brunel and East Malaysia (Sarawak and Sadah)
157 :	TOKYO		: Japan
158 :			: Korea
159 :			: Okinawa
160 :	TRISTAN ASTRO 1968		: Tristan da Cunha
161 :	VITI LEVU 1916		: Viti Levu Island (Fiji Islands)
162 :	WAKE-ENIWETOK 1960		: Marshall Islands
163 :	ZANDERIJ		: Suriname
164 :	BUKIT RIMPAH		: Bangka and Belltung Islands (Indonesia)
165 :	CAMP AREA ASTRO		: Camp Mcmurdo Area, Antarctica
166 :	G. SEGARA		: Kalimantan Islands(Indonesia)
167 :	HERAT NORTH		: Afghanistan
168 :	HU-TZU-SHAN		: Taiwan
169 :	TANANARIVE OBSERVATORY 1925		: Madagascar
170 :	YACARE		: Uruguay
171 :	RT-90		: Sweden
172 :	PULKOVO 1942		: Russia
173 :	FINNISH KJK		: Finland

6. What is WAAS?

WAAS, available in North and South America mainly, is a provider in the worldwide SBAS (Satellite Based Augmentation System) navigation system. SBAS provides GPS signal corrections to SBAS users, for even better position accuracy, typically better than three meters. There are three more SBAS providers, MSAS (Multi-Functional Satellite Augmentation System), EGNOS (Euro Geostationary Navigation Overlay Service) and GAGAN (GPS Aided Geo Augmented Navigation). All providers are compatible with one another, thus providing seamless position fixes to SBAS users. The illustration below shows the coverage area of the SBAS. (Accuracy may be affected when using a GEO satellite not within your current location.) This manual uses WAAS for these three providers generically.

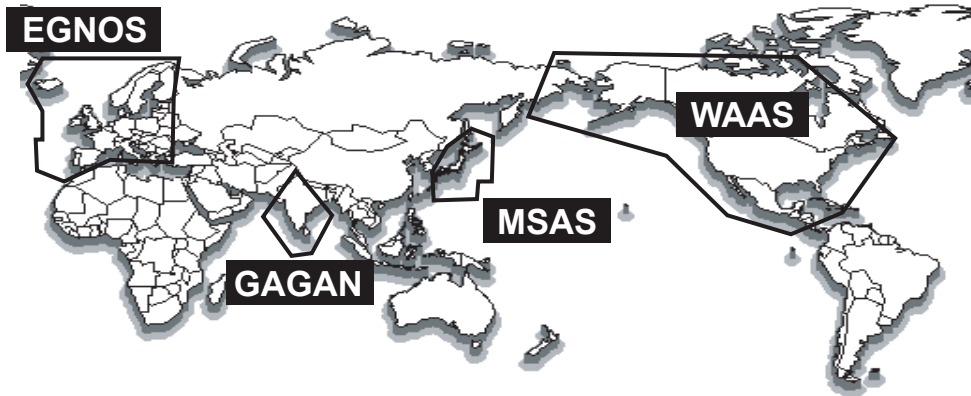

Provider	Satellite type	Longitude	Satellite No.
WAAS	Intelsat Galaxy XV	133°W	135
	TeleSat Anik F1R	107.3°W	138
EGNOS	Inmarsat-3-F2/AOR-E	15.5°W	120
	Artemis	21.5°E	124
	Inmarsat-3-F5/IOR-W	25°E	126
MSAS	MTSAT-1R	140°E	129
	MTSAT-2	145°E	137
GAGAN	Inmarsat-4-F1/IOR	64°E	127

7. Terminology, Units of Measurement, Symbols

Terminology

Term	Meaning
AIS	Automatic Identification System
ALARM	Alarm
ALM	Alarm
ANT	Antenna
APR	April
ARPA	Automatic Radar Plotting Aid
AUG	August
AUTO	Automatic
AVG	Average
B-EXT	External Beacon (DGPS Receiver)
BPS	Bit Per Second
CALC	GPS baseline Calculation
CNT	Contour
COG	Course Over Ground
DEC	December
DGPS	Differential GPS
DIFF	Difference
DIM	Dimmer
DISP	Display
DIST	Distance
DRIFT	Drift
E	East
ECDIS	Electronic Chart Display and Information System
EGNOS	European Geo-Stationary Navigational Overlay System
ENT	Enter
ERR	Error
EXT	External
FIX	Fix
FREQ	Frequency
GNSS	Global Navigation Satellite System
GOOD	Good
GPS	Global Positioning System

Term	Meaning
HDG	Heading
ID	Identification
IEC ED1	IEC 61162-1 Edition 1 (NMEA 0183 Version 2.0)
IEC ED2	IEC 61162-1 Latest Edition (NMEA 0183 Latest Version)
IN	In
I/O	Input/Output
JAN	January
JUL	July
JUN	June
LAT	Latitude
LCD	Liquid Crystal Display
L/L	Latitude/Longitude
LOG	Log
LON	Longitude
MAN	Manual
MAR	March
MAY	May
MENU	Menu
MSAS	Multi-Functional Satellite Augmentation System
N	North
NAV	Navigation
NG	Not good
NMEA 1.5	NMEA 0183 Version 1.5
NOV	November
OCT	October
OFF	Off
OFFSET	Offset
ON	On
OUT	Out/Output
POS	Position
PRCSSR	Processor Unit
PWR	Power



Term	Meaning
RAM	Random Access Memory
ROM	Read Only Memory
ROT	Rate of Turn
RX	Receive
S	South
SAT	Satellite
SC	Satellite Compass
SEC	second
SET	Set
SEP	September
SIG	Signal
SIM	Simulation
SNR	Signal To Noise Ratio

Term	Meaning
SOG	Speed Over Ground
STW	Speed Through the Water
SV	Satellite
T	True
TEST	Test
THD	Transmitting Heading Device
TIME	Time
TX	Transmit
UTC	Universal Time, Coordinated
VER	Version
W	West
WAAS	Wide Area Augmentation System
WGS	World Geodetic System

Units of measurement

Unit	Meaning
°	degree
°/min	degree/minute
dB	decibel
kHz	kiloHertz
km	kilometer
kn	knot
m	meter
min or '	minute(s)
m/s	meter/second
ms	millisecond
NM	Nautical Mile
p/NM	Pulse/Nautical Mile
s	second(s)

Symbols

Symbol	Meaning
	Heading Calculation Status, acquiring satellite. See section 2.4.1.
	Heading Calculation Status, calculating heading. See section 2.4.1.
	Heading Calculation Status, final calculations. See section 2.4.1.
BCK	Display last-used heading data at power on or not. See section 2.11.
S	Simulated operation. See section 2.9.5.
EXT	Heading fed from external equipment. See section 2.14.

**SPECIFICATIONS OF SATELLITE COMPASS
SC-50**

1 GENERAL

- 1.1 Heading accuracy 0.5° RMS
- 1.2 Heading resolution 0.1°
- 1.3 Follow-up 45°/s rate-of-turn
- 1.4 Settling time 3 minutes
- 1.5 Position accuracy 10 m, or 5 m (DGPS), 95% of the time
- 1.6 Heading/Nav data output
 - Number of port AD-10 format specialty: 1 port
AD-10: 5 ports or IEC 61162-1/2: 10 ports (selected from menu)
IEC 61162 format is RS-485 level
 - Sentences ATT, GGA, GLL, GNS, HDM, HDT, HVE, RMC, ROT, THS, VBW, VDR, VHW, VTG, ZDA
- 1.7 Log pulse output 1 port, contact signal
- 1.8 Heading alarm output 1 port, contact signal, 48V, 1A max.
- 1.9 Motion signal output Pitch:1 port, Roll: 1 port
- 1.10 External heading input 1 port: AD-10 or IEC61162-1/2 format (auto recognition)
 - AD-10 Backup heading
 - IEC 61162 Water tracking speed
 - Sentences HDG, HDM, HDT, VBW, VHW, VLW
- 1.11 External beacon input 1 port, RTCM SC-104 format (RS-232C level)

2 DISPLAY UNIT

- 2.1 Display type 4.5 inch monochrome LCD, 120 x 64 dots
- 2.2 Effective area 60 mm (H) x 95 mm (W)
- 2.3 Contrast 64 levels
- 2.4 Display mode Heading, Nav data, Steering, Compass rose, Rate of turn and Speed modes

3 POWER SUPPLY

12-24 VDC: 1.2-0.5 A

4 ENVIRONMENTAL CONDITIONS

- 4.1 Ambient temperature
 - Display/ Processor unit -15°C to +55°C, designed for protected area
 - Antenna unit -25°C to +70°C, designed for exposed area
- 4.2 Relative humidity 93% at 40°C
- 4.3 Degree of protection
 - Antenna unit IPX6
 - Display unit IPX5
 - Processor unit IPX0
- 4.4 Vibration IEC 60945

5 COATING COLOR





5.1	Display unit	Panel: N3.0, Chassis: 2.5GY5/1.5
5.2	Processor unit	2.5GY5/1.5
5.3	Antenna unit	N9.5

PACKING LIST

20AY-X-9854 -3 1/1

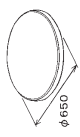
SC-303

A-1

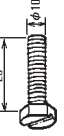
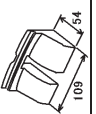
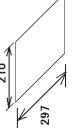
NAME	OUTLINE	DESCRIPTION/CODE	QTY
ユニット			
GPSアンテナ		SC-303	1
GPS ANTENNA		000-041-925	
工事材料			
INSTALLATION MATERIALS			
鳥よけ		20-024-3101-3	9
BIRD-REPELLENT FIXTURE		100-315-303	
バネ座金		M10 SUS304	4
SPRING WASHER		000-864-261	
ミガキ平座金		M10 SUS304	4
FLAT WASHER		000-864-131	
六角ボルト 刃割		M10X25 SUS304	4
HEX BOLT (SLOTTED HEAD)		000-862-308	
ケーブルカバー		20-020-3213-1	1
ケーブルカバー		100-291-511	
図書			
型紙		C72-00303-*	1
TEMPLATE		000-149-150	

(略図の寸法は、参考値です。 DIMENSIONS IN DRAWING FOR REFERENCE ONLY.)

C7251-Z03-C

FURUNO

A-2

CODE NO.	004-378-110-00	20AT-X-9408-1			
TYPE	CP20-02230	1/1			
工事材料表					
INSTALLATION MATERIALS					
番号	名称	略図	型名/規格	数量	用途/備考
NO.	NAME	OUTLINE	DESCRIPTIONS	QTY	REMARKS
1	ケーブル(組品)		TPPAG-302V-15M	1	
	ANTENNA CABLE ASSEMBLY	L=15M	CODE NO. 001-246-170-30		

型式/コード番号が2段の場合、下段より上段に代わる過渡期品であり、どちらかが入っています。なお、品質は変わりません。

TWO TYPES AND CODES MAY BE LISTED FOR AN ITEM. THE LOWER PRODUCT MAY BE SHIPPED IN PLACE OF THE UPPER PRODUCT. QUALITY IS THE SAME. DIMENSIONS IN DRAWING FOR REFERENCE ONLY.)

*

FURUNO ELECTRIC CO., LTD.

C7248-M06-B

FURUNO**工事材料表**

INSTALLATION MATERIALS

番号 NO.	名称 NAME	略図 OUTLINE	型名/規格 DESCRIPTIONS	数量 Q'TY	用途/備考 REMARKS
1	ケーブル組品 CABLE ASSY.		TNC-PS/PS-3D-LI5M-R CODE NO. 000F-135-670-11	3	

CODE NO.	004-379-660-00	20AT-X-9410 -1
TYPE	CP20-02260	

1/1

FURUNO**工事材料表**

INSTALLATION MATERIALS

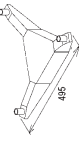
番号 NO.	名称 NAME	略図 OUTLINE	型名/規格 DESCRIPTIONS	数量 Q'TY	用途/備考 REMARKS
1	アンテナ組品(S) ANTENNA BASE ASSY. (S)		CP20-02201 CODE NO. 004-377-570	1	

CODE NO.	004-377-570	20AT-X-9401 -1
TYPE	CP20-02201	

1/1

型式/コード番号が2段の場合、下段より上段に代わる通線層があり、どちらが入っています。なお、層間は変わりません。
TWO TYPES AND CODES MAY BE LISTED FOR AN ITEM. THE LOWER PRODUCT MAY BE SHIPPED IN PLACE OF THE UPPER PRODUCT. QUALITY IS THE SAME.
(略図の寸法は、参考値です。)

FURUNO ELECTRIC CO.,LTD.

DIMENSIONS IN DRAWING FOR REFERENCE ONLY.)

FURUNO ELECTRIC CO.,LTD.

C7248-M08-B

(略図の寸法は、参考値です。
FURUNO ELECTRIC CO.,LTD.
DIMENSIONS IN DRAWING FOR REFERENCE ONLY.)

C7248-M01-B

PACKING LIST
SC-502-J/-HK, E/-HK

20AT-X-9851 -4 1/1
A-6

NAME	UNIT	OUTLINE	DESCRIPTION/CODE No.	Q'TY
ユニット				
表示部			SC-502-J/-HK, E/-HK	1
付属品	ACCESSORIES		000-041-906-00 FP14-02801	
保護カバー			20-016-1091-2 R0HS	1
COVER			100-297-032-10 CP20-02203	
工事材料	INSTALLATION MATERIALS			
+ワッシャー	ワッシャー		5X20 SUS304	4
SELF-TAPPING SCREW			000-162-608-10	

1.コード番号末尾の「**」は、選択品の代表型/コードを表します。
CODE NUMBER ENDED BY “**” INDICATES THE NUMBER OF TYPICAL MATERIAL.

型/コード番号が2段の場合、下段より上段に代わる過渡部品であり、どちらかが入っています。なお、品質は変わりません。
TWO TYPES AND CODES MAY BE LISTED FOR AN ITEM. THE LOWER PRODUCT MAY BE SHIPPED IN PLACE OF THE UPPER PRODUCT. QUALITY IS THE SAME.
(略図の寸法は、参考値です。DIMENSIONS IN DRAWING FOR REFERENCE ONLY.)

C7251-Z01-D

A-5

CODE NO.	004-377-590-00	20AT-X-9404-10			
TYPE	CP20-02202	1/1			
工事材料表					
番号	名称	略図	型名/規格	数量	用途/備考
1	固定用金具S FIXING FIXTURE S		20-019-3351-4 CODE NO. 100-284-844-10	1	
2	補助金具 ATTACHMENT PLATE		20-019-3352-1 R0HS CODE NO. 100-284-851-10	1	
3	鳥除け BIRD DETERRENT		20-024-3101-3 R0HS CODE NO. 100-315-303-10	4	
4	バネ座金 SPRING WASHER		H8 SUS304 CODE NO. 000-167-410-10	3	
5	平丸平座金 FLAT WASHER		H8 SUS304 CODE NO. 000-167-419-10	3	
6	六角ナット HEX NUT		H8 SUS304 CODE NO. 000-167-479-10	6	
7	シリコン SILICON RUBBER		S-8400M 7x3x1.7-50G CODE NO. 000-155-483-11	1	

型/コード番号が2段の場合、下段より上段に代わる過渡部品であり、どちらかが入っています。なお、品質は変わりません。
TWO TYPES AND CODES MAY BE LISTED FOR AN ITEM. THE LOWER PRODUCT MAY BE SHIPPED IN PLACE OF THE UPPER PRODUCT. QUALITY IS THE SAME.
(略図の寸法は、参考値です。DIMENSIONS IN DRAWING FOR REFERENCE ONLY.)

FURUNO ELECTRIC CO., LTD.

C7248-M03-K

PACKING LIST
SC-501-J/-HK, E/-HK

20AY-X-9852 -5 1/1
A-7

NAME	OUTLINE	DESCRIPTION/CODE No.	QTY
ユニット			
演算部 PROCESSOR UNIT		SC-501/-HK 000-041-903-00**	1
予備品			
予備品 SPARE PARTS		SP20-01101 004-379-720-00 GP20-02600	1
工事材料			
ケーブル組品組 CABLE ASSY.		MJ-A/SPF0006-100C 000-159-680-10	1
工事材料 INSTALLATION MATERIALS		GP20-02601 004-380-560-00	1
図書			
取扱説明書 OPERATOR'S MANUAL		004-72510-* 000-160-405-1*	1

コード番号末尾の[*]**は、選択品の代表型式/コードを表します。
CODE NUMBER ENDED BY ** INDICATES THE NUMBER OF TYPICAL MATERIAL.

型式/コード番号が2股の場合、下段より上段に代わる過渡期品であり、どちらかが入っています。なお、品質は変わりません。
TWO TYPES AND CODES MAY BE LISTED FOR AN ITEM. THE LOWER PRODUCT MAY BE SHIPPED IN PLACE OF THE UPPER PRODUCT. QUALITY IS THE SAME.
(略図の寸法は、参考値です。DIMENSIONS IN DRAWING FOR REFERENCE ONLY.)

C7251-Z02-F

FURUNO

A-8





CODE NO.	004-380-560-00	20AY-X-9401-5			
TYPE	CP20-02601	1/1			
工事材料表					
INSTALLATION MATERIALS					
番号 NO.	名称 NAME	略図 OUTLINE	型名/規格 DESCRIPTIONS	数量 QTY	用途/備考 REMARKS
1	ケーブルラベル CABLE LABEL		20-024-2024-0 ROHS 20-024-2024-0 CODE NO. 100-310-770-10 100-310-770-30	1	
2	端子開閉器 TERMINAL OPENER		231-131 231-131 CODE NO. 000-165-800-11 000-165-800-10	2	
3	セルフタップネジ SELF-TAPPING SCREW		5X20 SUS304 CODE NO. 000-162-608-10	4	

型式/コード番号が2股の場合、下段より上段に代わる過渡期品であり、どちらかが入っています。なお、品質は変わりません。
TWO TYPES AND CODES MAY BE LISTED FOR AN ITEM. THE LOWER PRODUCT MAY BE SHIPPED IN PLACE OF THE UPPER PRODUCT. QUALITY IS THE SAME.
(略図の寸法は、参考値です。DIMENSIONS IN DRAWING FOR REFERENCE ONLY.)

FURUNO ELECTRIC CO., LTD.

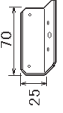
C7251-M01-E

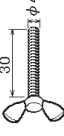
CODE NO.	000-040-720-00	20AY-X-9403-5
TYPE	0P20-17	1/1

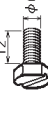
工事材料表		INSTALLATION MATERIALS			
番号 NO.	名称 NAME	略図 OUTLINE	型名/規格 DESCRIPTIONS	数量 QTY	用途/備考 REMARKS
1	フラッシュマウント FLUSH MOUNT		ZD-007-2401-O R0HS CODE NO. 100-183-190-10	2	
2	蝶ナット 2種 WING NUT 2 SYU		M4 YBSC2 CODE NO. 000-182-183-10	4	
3	蝶ボルト WING BOLT		M4X30 YBSC2 CODE NO. 000-188-243-10	4	
4	ハネばね SPRING WASHER		M6 SUS304 CODE NO. 000-188-385-10	2	
5	六角穴付 ボルト HEX BOLT (SLOTTED HEAD)		M6X12 SUS304 CODE NO. 000-162-397-10	2	

(略図の寸法は、参考値です。 DIMENSIONS IN DRAWING FOR REFERENCE ONLY.)

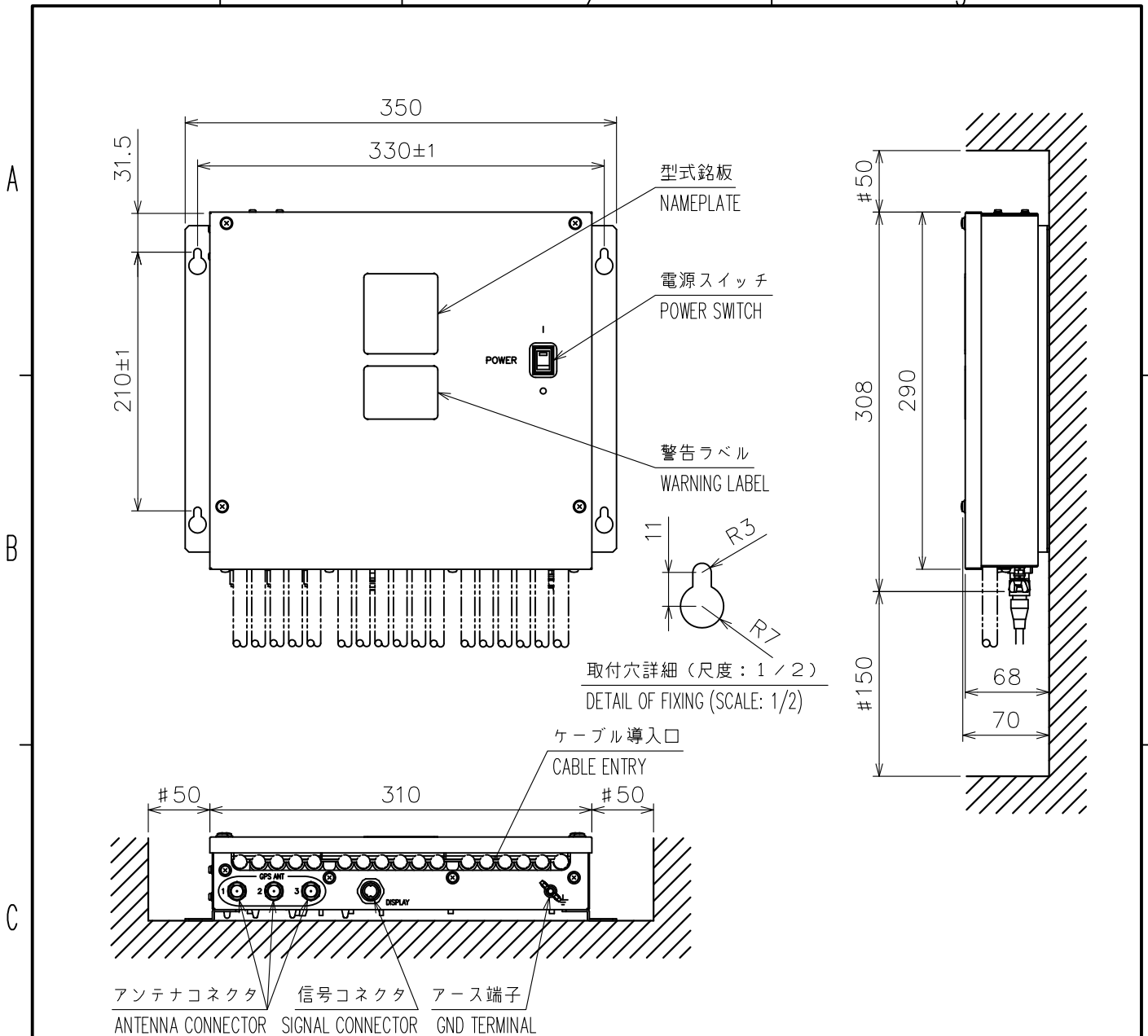

注記

- 1) 指定外寸法公差は表 1 による。
- 2) # 印寸法は最小サービス空間寸法とする。
- 3) 取付用ネジはトラスタッピンネジ呼び径5×20を使用のこと。

表 1 TABLE 1

寸法区分 (mm) DIMENSIONS	公差 (mm) TOLERANCE
0 < L ≤ 50	±1.5
50 < L ≤ 100	±2.5
100 < L ≤ 500	±3

NOTE

1. TABLE 1 INDICATES TOLERANCE OF DIMENSIONS WHICH IS NOT SPECIFIED.
2. #: MINIMUM SERVICE CLEARANCE.
3. USE TAPPING SCREWS $\phi 5 \times 20$ FOR FIXING THE UNIT.

DRAWN 5/Oct/2011 T.YAMASAKI	TITLE SC-501/1101
CHECKED 5/Oct/2011 H.MAKI	名称 演算部
APPROVED Y. Hatai	SC-50/110 外寸図
SCALE 1/5 MASS 4.2 ±10% kg	NAME PROCESSOR UNIT
DWG. No. C7251-G01-C	REF. No. 20-024-100G-3 OUTLINE DRAWING

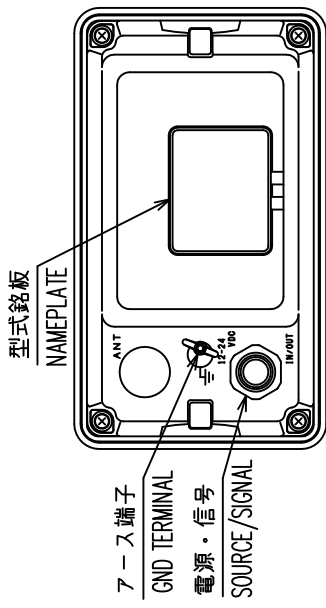
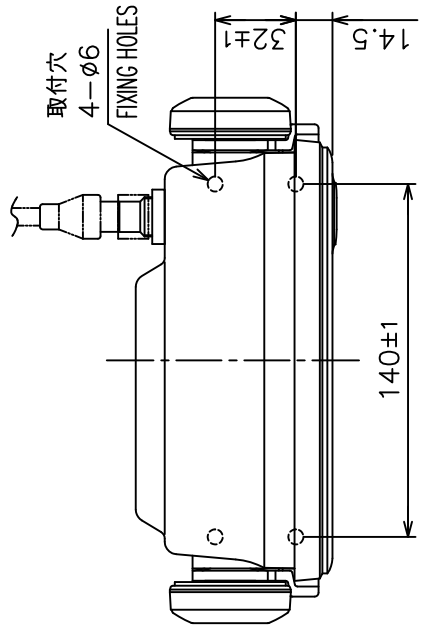

背面
REAR VIEW



表 1 TABLE 1

寸法区分 (mm) DIMENSION	公差 (mm) TOLERANCE
L ≤ 50	±1.5
50 < L ≤ 100	±2.5
100 < L ≤ 500	±3

- 注記 1) 指定外寸法公差は表 1 による。
 2) # 印寸法は最小サービスクリアランスとする。
 3) 装備ケーブルはサービスクリアランスを前方に十分引き出せるよう余裕を持たせること。
 4) 取付用ネジはトラスチックピンネジ呼び径 5 × 2.0 を使用のこと。
- NOTE 1. TABLE 1 INDICATES TOLERANCE OF DIMENSIONS WHICH IS NOT SPECIFIED.
 2. # MINIMUM SERVICE CLEARANCE.
 3. KEEP SUFFICIENT CABLE LENGTH BEHIND THE UNIT FOR MAINTENANCE.
 4. USE TAPPING SCREWS φ5x2.0 FOR FIXING THE UNIT.

DRAWN	13/Jan/2011	T. YAMASAKI	TITLE	SC-502/602
CHECKED	13/Jan/2011	H. MAKI	名称	表示部 (卓上装備)
APPROVED	17/Jan/2011	Y. NISHIYAMA	外寸図	
SCALE	1/3	MASS 0.55 kg	NAME	DISPLAY UNIT (TABLETOP MOUNT)
DWG.No.	C7248-G02-J	REF.No.	20-024-200G-1	OUTLINE DRAWING

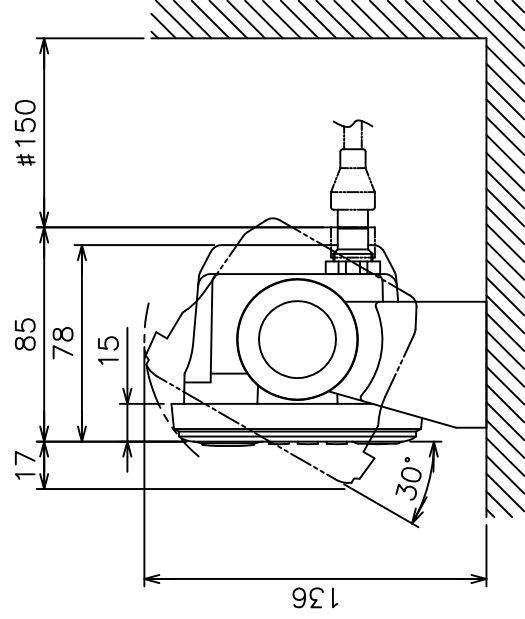
表 1 TABLE 1

寸法区分 (mm) DIMENSIONS	公差 (mm) TOLERANCE
0 < L ≤ 50	±1.5
50 < L ≤ 100	±2.5
100 < L ≤ 500	±3

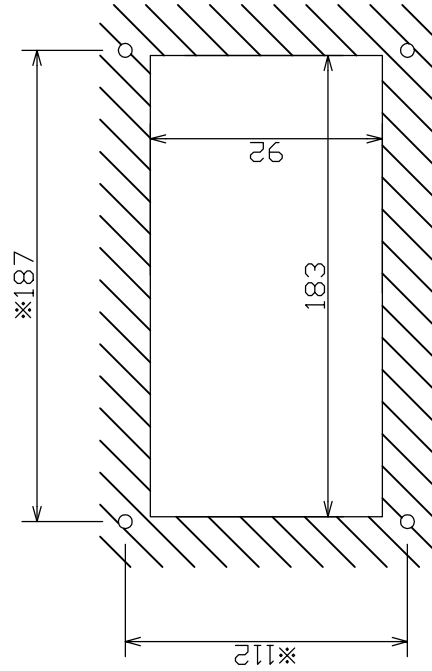
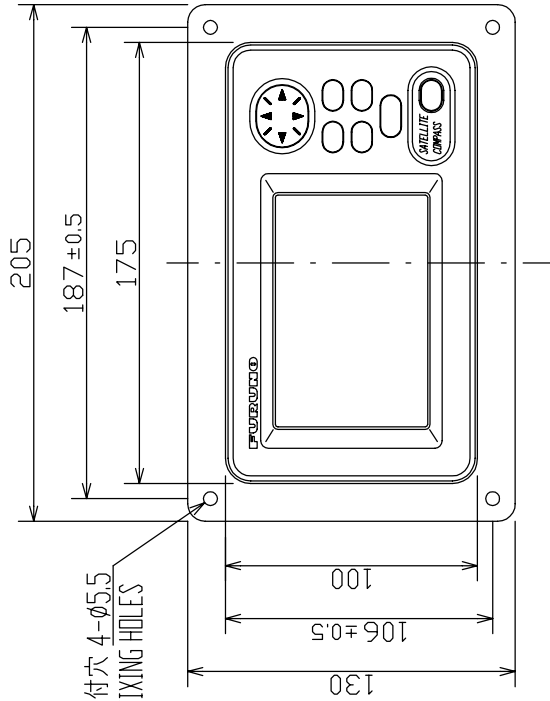
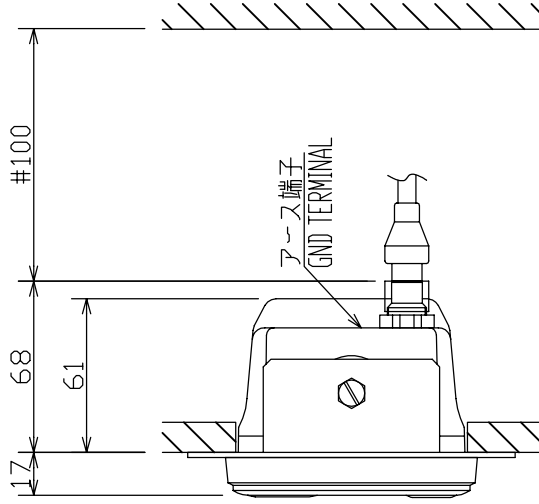

取付穴寸法図 (参考図)
CUTOUT DIMENSIONS

- 注 記
- ※印寸法は取付穴位置寸法とする。
 - 取付用ネジはトラスタップピングネジ呼び径5×20を使用のこと。
 - 指定外寸法公差は表1による。
 - ※印寸法は最小サービス空間寸法とする。

- NOTE
- ※ DIMENSIONS FOR FIXING HOLE POSITIONS.
 - USE TAPPING SCREWS 5x20 FOR FIXING THE UNIT.
 - TABLE 1 INDICATES TOLERANCE OF DIMENSIONS WHICH IS NOT SPECIFIED.
 - ※ MINIMUM SERVICE CLEARANCE.

DRAWN No. 17/04	E. MIYOSHI Takahashi T.	TITLE	SC-502/602
CHECKED		名称	表示部 (埋込装備 F)
APPROVED	Y. Hatai	外寸図	
SCALE	1/3	NAME	DISPLAY UNIT (FLUSH MOUNT F)
DRG.No.	C7248-G03-G	OUTLINE DRAWING	
			20-024-210G-0

表 1 TABLE 1

寸法区分 (mm) DIMENSIONS	公差 (mm) TOLERANCE
L ≤ 50	±1.5
50 < L ≤ 100	±2.5
100 < L ≤ 500	±3

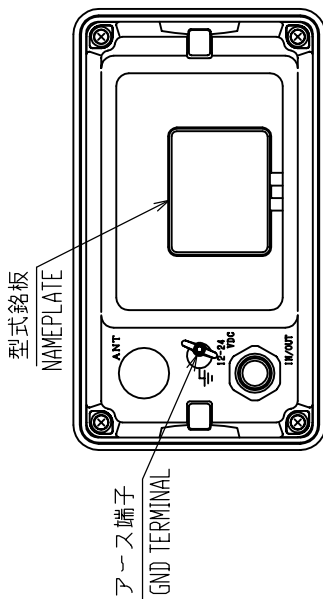
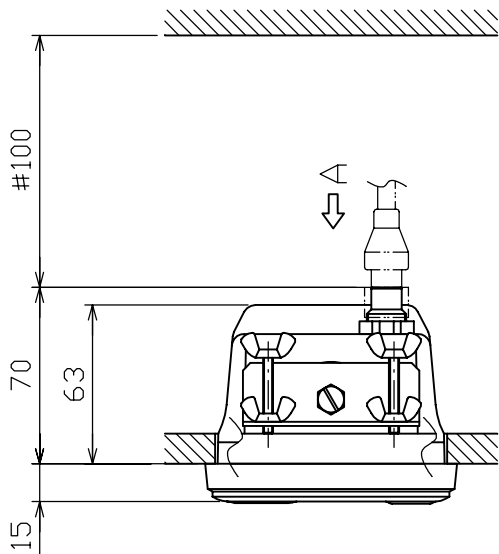

矢視 A
VIEW A

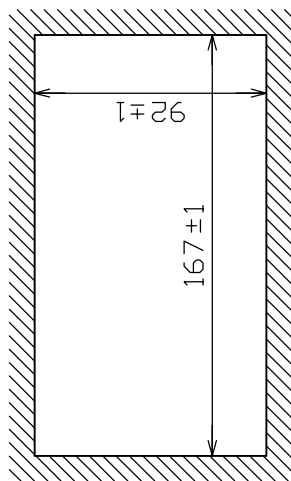
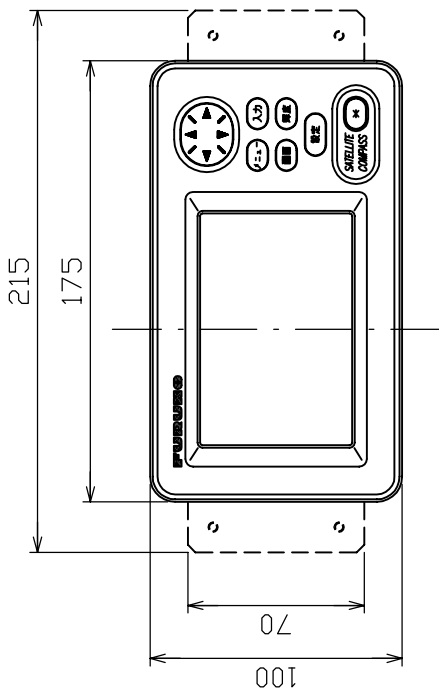

取付穴寸法図(参考図)

CUTOUT DIMENSIONS

- 注記 1) 指定外寸公差は表 1 による。
 2) #印寸法は最小サービス空間寸法とする。
- NOTE 1. TABLE 1 INDICATES TOLERANCE OF DIMENSIONS WHICH IS NOT SPECIFIED.
 2. # MINIMUM SERVICE CLEARANCE.

DRAWN No. 17/04	E. MIYOSHI	TITLE	SC-502/602
CHECKED	Takahashi T.	名称	表示部 (埋込装置 S)
APPROVED	Y. Hatai	外寸図	
SCALE	1/3	NAME	DISPLAY UNIT (FLUSH MOUNT S)
DRG.No.	C7248-G04-F	OUTLINE DRAWING	
			20-024-220G-0

表 1 TABLE 1

寸法区分 (mm) DIMENSIONS	公差 (mm) TOLERANCE
L ≤ 50	±1.5
50 < L ≤ 100	±2.5
100 < L ≤ 500	±3
500 < L ≤ 1000	±4

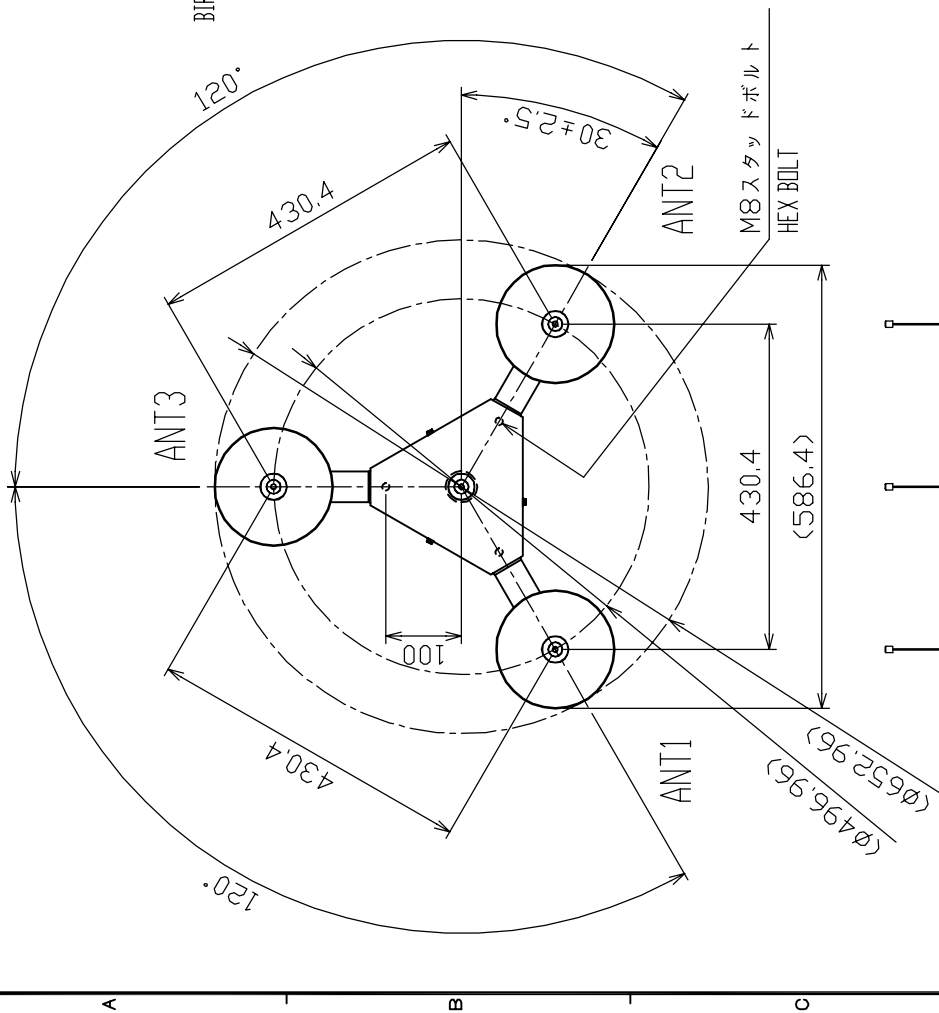
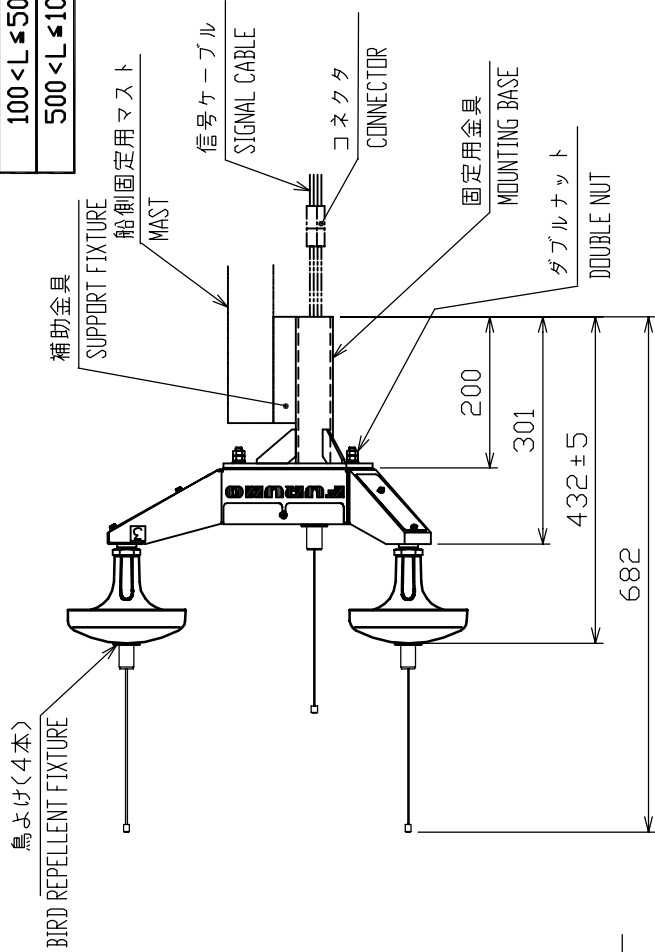

船首方向
BOW

- 注 記
- 1) 指定外の寸法公差は表 1 による。
 - 2) 取付けは補助金具を溶接し、しっかりと固定のこと。
 - 3) 質量は工事材料(鳥よけ; 0.02kg × 4本、固定用金具; 2kg、補助金具、M8ナット、SW、PW、スリーボンド1211)を含まず。

- NOTE
1. TABLE 1 INDICATES TOLERANCE OF DIMENSIONS WHICH IS NOT SPECIFIED.
 2. WELD SUPPORT FIXTURE.
 3. MASS DOES NOT INCLUDE INSTALLATION MATERIALS (BIRD-REPELLENT FIXTURE, 0.02 kg x 4 PCS; MOUNTING BASE, 2 kg; SUPPORT FIXTURE, M8 NUT, SPRING WASHER, FLAT WASHER, SILICONE RUBBER THREEBOND 1211).

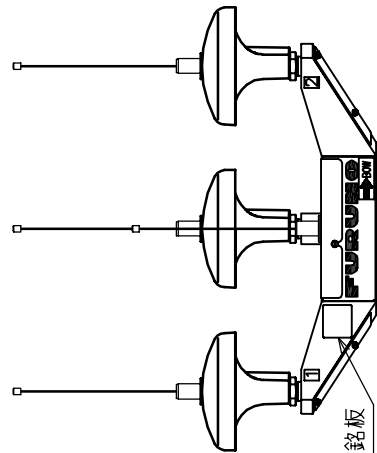

DRAWN Nov. 14, '05 E. MIYOSHI	TITLE SC-603
CHECKED TAKAHASHI, T	名称 空中線部
APPROVED Y. Hatai	外寸図
SCALE 1/10	縮尺 3.9 kg
DWG. No. C7248-605-E	20-019-310G-3
	NAME ANTENNA UNIT
	OUTLINE DRAWING

表 1 TABLE 1

寸法区分 (mm) DIMENSIONS	公差 (mm) TOLERANCE
L ≤ 50	±1.5
50 < L ≤ 100	±2.5
100 < L ≤ 500	±3
500 < L ≤ 1000	±4

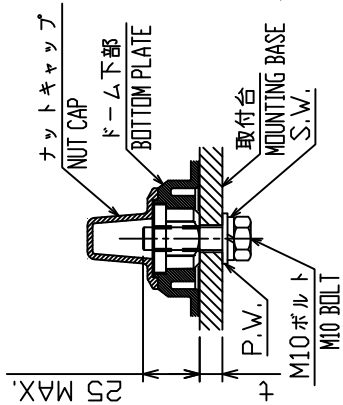
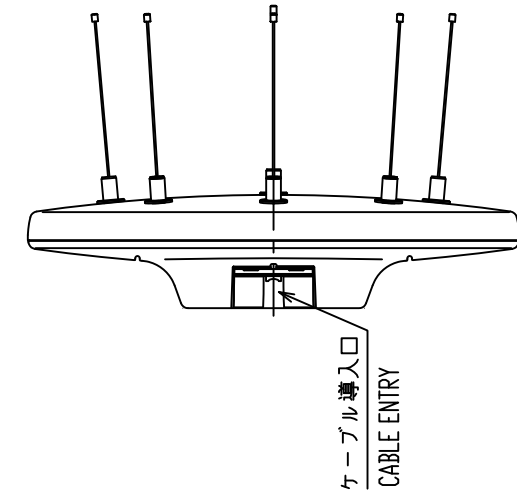
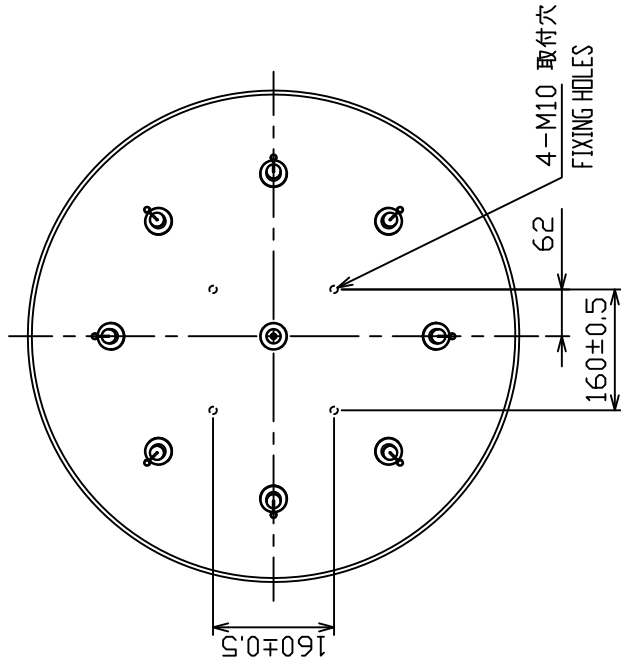
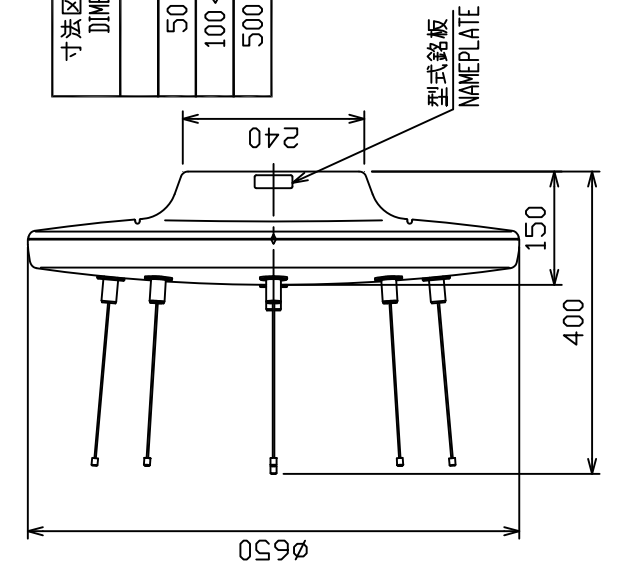

△部詳細 (尺度 1/3)
DETAIL OF A (SCALE: 1/3)

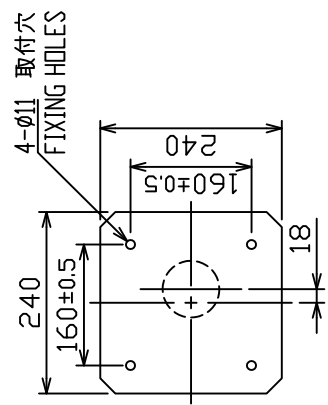
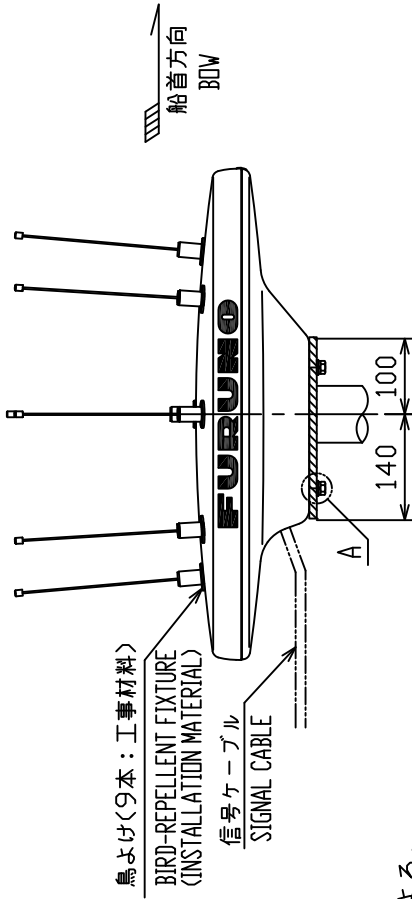

取付台 (マスト) 製作例
EXAMPLE OF MOUNTING BASE (MAST)

注記

- 1) 指定外の寸法公差は表 1 による。
- 2) 取付用ネジは M10 ボルトを使用のこと。
ネジ長さは板厚 t に応じて、25 (t ≤ 5) または 30 (5 < t ≤ 10) とする。

NOTE

1. TABLE 1 INDICATES TOLERANCE OF DIMENSIONS WHICH IS NOT SPECIFIED.
2. USE M10 BOLTS FOR FIXING THE UNIT.
SCREW LENGTH: 25 (t ≤ 5) OR 30 (5 < t ≤ 10). t: THICKNESS OF MOUNTING BASE.

DRAWN	Feb. 28 '08	I. YAMASAKI	TITLE	SC-303
CHECKED	Feb. 29 '08	T. TAKENO	名称	空中線部
APPROVED	2/Apr/08	R. Esumi	外寸図	
SCALE	1/10	質量 4.2 kg	機種	ANTENNA UNIT
DWG No.	C7248-G06-G	質量 W/O INSTALLATION MATERIAL	20-020-300G-3	OUTLINE DRAWING

A

B

C

D

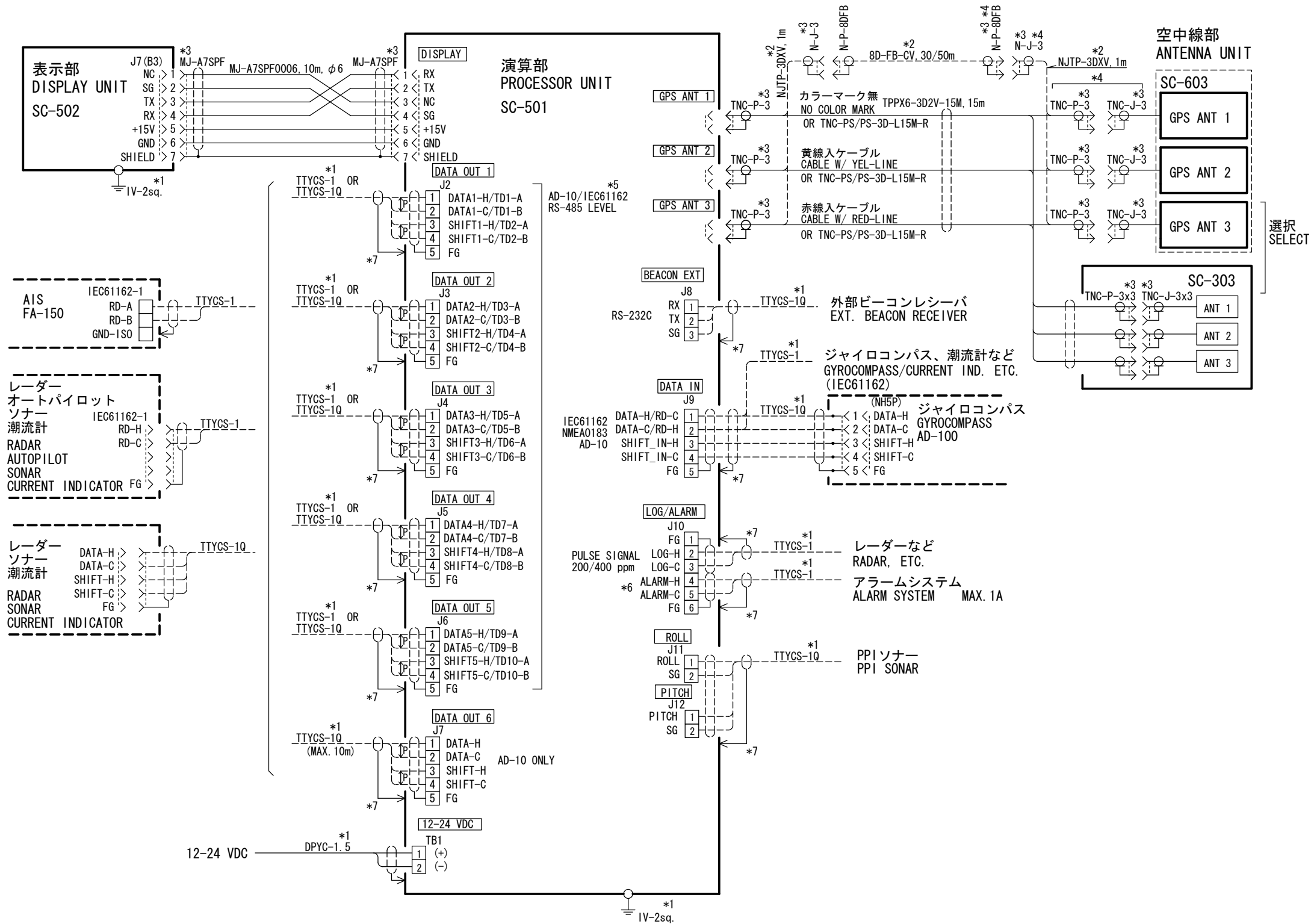

注記

- * 1) 造船所手配。
- * 2) オプション。
- * 3) 工場にて取付済み
- * 4) 防水のためテープで処理すること。
- * 5) メニュー切替。
- * 6) 方位出力が停止したとき、接点回路がオープンになる。
- * 7) ケーブルクランプでアースを取る。

NOTE

- *1. SHIPYARD SUPPLY.
- *2. OPTION.
- *3. FITTED AT FACTORY.
- *4. TAPE FOR WATERPROOFING.
- *5. SELECT FROM MENU.
- *6. IF THE HEADING OUTPUT STOPS, THE CONTACT CIRCUIT OPENS.
- *7. GROUND THROUGH CABLE CLAMP.

DRAWN	7/Dec/2012 T. YAMASAKI	TITLE	SC-50
CHECKED	10/Dec/2012 H. MAKI	名称	サテライトコンパス
APPROVED	10/Dec/2012 Y. NISHIYAMA		相互結線図
SCALE	MASS kg	NAME	SATELLITE COMPASS
DWG. No.	C7251-C01- H	REF. No.	20-024-5000-3
		INTERCONNECTION DIAGRAM	

INDEX

A

Alarms menu 2-6

B

Battery replacement 3-8

C

Compass display 2-4

Control description 2-1

D

Data clearing 3-7

Demonstration mode 2-16

Diagnostics

test 1 3-3

test 2 3-5

test 3 3-6

DIM key 2-2

DISP key 2-3

Distance run display 2-4

Distance run resetting 2-21

E

Error messages 3-9

F

Fuse replacement 3-9

G

Geodetic data 2-14

GPS setup menu 2-8

H

Heading

backup 2-19

external source for backup 2-21

output 2-9

restoration 2-19

Heading display 2-3

L

Local time 2-15

Log pulse 2-13

M

Maintenance

battery replacement 3-8

cleaning 3-1

fuse replacement 3-9

Menu tree AP-1

N

Nav data display 2-4

O

OTHERS menu 2-19

Output data setup menu 2-9

P

Position offset 2-8

Power on/off 2-2

Program version no. 3-7

R

Rate-of-turn display 2-4

ROT range, smoothing 2-20

S

SAT STATUS key 2-1

Satellite status display 2-7

Satellites

disabling 2-9

status display 2-7

Smoothing 2-8

SOG/STW display 2-5

Steering display 2-4

System configuration vi

System setup menu 2-14

T

Time format 2-15

TRIP menu 2-20

Troubleshooting 3-2

U

Units of measurement 2-15

W

WAAS/DGPS menu 2-17

Declaration of Conformity



0735

We **FURUNO ELECTRIC CO., LTD.**

(Manufacturer)

9-52 Ashihara-Cho, Nishinomiya City, 662-8580, Hyogo, Japan

(Address)

declare under our sole responsibility that the product

SATELLITE COMPASS SC-50

(Model name, type number)

to which this declaration relates conforms to the following standard(s) or normative document(s)

IMO Resolution MSC.116(73)	ISO 22090-3: Ed.1.0: 2004 incl. Corr. 1: 2005
IMO Resolution A.694(17)	IEC 60945: Ed.4.0: 2002 incl. Corr. 1: 2008
IMO Resolution MSC.191(79)	IEC 62288: Ed.1.0: 2008
IMO Resolution MSC.36(63)-(1994 HSC Code) 13	IEC 61162-1: Ed.4.0: 2010
IMO Resolution MSC.97(73)-(2000 HSC Code) 13	IEC 61162-2: Ed.1.0: 1998

(title and/or number and date of issue of the standard(s) or other normative document(s))

For assessment, see

- EC type examination (Module B) certificate No.4581/001/4412568/13 issued by Federal Maritime and Hydrographic Agency (BSH), The Federal Republic of Germany.
- EC quality system (Module D) certificate No.BSH/4613/02208/2345/12 issued by Federal Maritime and Hydrographic Agency (BSH), The Federal Republic of Germany.

This declaration is issued according to the provisions of European Council Directive 96/98/EC on marine equipment modified by Commission Directive 2012/32/EU and 2013/52/EU.

On behalf of Furuno Electric Co., Ltd.

Nishinomiya City, Japan
December 16, 2013

(Place and date of issue)

Yoshitaka Shogaki
Manager, QMS Secretariat
Quality Assurance Department

(name and signature or equivalent marking of authorized person)