

FURUNO

OPERATOR'S MANUAL

MARINE RADAR

MODEL MODEL 841 MARK-2



FURUNO ELECTRIC CO., LTD.
NISHINOMIYA, JAPAN

© **FURUNO ELECTRIC CO., LTD.**

9-52, Ashihara-cho,
Nishinomiya, Japan 662

Telephone: 0798-65-2111
Telefax: 0798-65-4200

All rights reserved. Printed in Japan

(TATA)

PUB. No. OME-34440
MODEL 841 MARK-2

•Your Local Agent/Dealer

FIRST EDITION : JAN 1997
E : OCT. 8, 1998



* 00080793000 *



SAFETY INSTRUCTIONS

"**WARNING**" and "**CAUTION**" notices appear throughout this manual. It is the responsibility of the operator and the installer of the equipment to read, understand and follow these notices. If you have any questions regarding these safety instructions, please contact a FURUNO agent or dealer.

The level of risk appearing in the notices is defined as follows:



WARNING

This notice indicates a potentially hazardous situation which, if not avoided, could result in death or serious injury.



CAUTION

This notice indicates a potentially hazardous situation which, if not avoided, could result in minor or moderate injury, or property damage.

Safety Instructions for the Operator



WARNING



Do not open the equipment.

Hazardous voltage which can cause electrical shock, burn or serious injury exists inside the equipment. Only qualified personnel should work inside the equipment.



Wear a safety belt and hard hat when working on the antenna unit.

Serious injury or death can result if someone falls from the radar antenna mast.



Stay away from transmitting antenna.

The radar antenna emits microwave radiation which can be harmful to the human body, particularly the eyes. Never look directly into the antenna radiator from a distance of less than 1 m when the radar is in operation.

Do not disassemble or modify the equipment.

Fire, electrical shock or serious injury can result.

Turn off the power immediately if water leaks into the equipment or the equipment is emitting smoke or fire.

Continued use of the equipment can cause fire or electrical shock.



WARNING

Do not operate the equipment with wet hands.

Electrical shock can result.

Keep heater away from equipment.

Heat can alter equipment shape and melt the power cord, which can cause fire or electrical shock.



CAUTION

Use the proper fuse.

Use of a wrong fuse can result in fire or permanent equipment damage.

Do not use the equipment for other than its intended purpose.

Personal injury can result if the equipment is used as a chair or stepping stool, for example.

Do not place objects on the top of the equipment.

The equipment can overheat or personal injury can result if the object falls.

Safety Instructions for the Installer



WARNING



Do not work inside the equipment unless totally familiar with electrical circuits.

Hazardous voltage which can cause electrical shock, burn or serious injury exists inside the equipment.



Wear a safety belt and hard hat when working on the antenna unit.

Serious injury or death can result if someone falls from the radar antenna mast.



If applicable, turn off the power at the mains switchboard before beginning the installation. Post a sign near the switch to indicate it should not be turned on while the equipment is being installed.

Fire, electrical shock or serious injury can result if the power is left on or is applied while the equipment is being installed.



CAUTION



Ground the equipment to prevent electrical shock and mutual interference.

Confirm that the power supply voltage is compatible with the voltage rating of the equipment.

Connection to the wrong power supply can cause fire or equipment damage. The voltage rating appears on the label at the rear of the display unit.

Use the correct fuse.

Use of a wrong fuse can cause fire or equipment damage.

TABLE OF CONTENTS

FOREWORD	v	2.25 Selecting Bearing Reference	18
SPECIFICATIONS	vii	2.26 Watchman	18
EQUIPMENT LIST	ix	2.27 Erasing the Heading Marker	19
CONFIGURATION	xi	2.28 Deselecting Ranges.....	19
1. PRINCIPLE OF OPERATION	1	2.29 Displaying Navigation During Stand-by	19
1.1 What is Radar?	1	2.30 Outputting Cursor Position to Navigator	20
1.2 How Ships Determined Position Before Radar	1	2.31 Displaying Cursor Position, Range and Bearing to Cursor	20
1.3 How Radar Determines Range	1	2.32 Visual Alarm Indications	20
1.4 How Radar Determines Bearing	1	3. INTERPRETING THE DISPLAY	
1.5 Radar Wave Speed and Antenna Rotation Speed	1	3.1 The Radar Wave and Radar Horizon	21
1.6 The Radar Display	1	3.2 Target Properties and Radar Wave Reflection	21
2. OPERATION		3.3 Range Resolution	22
2.1 Control Description	3	3.4 Bearing Resolution	22
2.2 Display Indications and Markers	4	3.5 False Echoes	22
2.3 Turning the Radar On and Off	4	3.6 Nautical Chart and Radar Picture ...	24
2.4 Transmitting	5	4. MAINTENANCE & TROUBLESHOOTING	
2.5 Selecting the Range	5	4.1 Safety Information	25
2.6 Adjusting LCD Backlighting and Display Tone	5	4.2 Preventative Maintenance	26
2.7 Adjusting Control Panel Brilliance ...	5	4.3 Replacing the Fuse	26
2.8 Adjusting GAIN, STC, A/C RAIN and FTC	6	4.4 Troubleshooting	27
2.9 Tuning the Receiver	7	4.5 Self Test	28
2.10 Measuring the Range	8	5. INSTALLATION	
2.11 Measuring the Bearing	8	5.1 Antenna Unit Installation	29
2.12 Menu Operation	9	5.2 Display Unit Installation	31
2.13 Selecting the Display Mode	11	5.3 Installation Check List	35
2.14 The Window Display	12	5.4 Initial Adjustment of Picture	36
2.15 Selecting the Presentation Mode	12	5.5 Displaying the Installation Menus ..	36
2.16 Guard Alarm	13	5.6 Entering Initial Settings	37
2.17 Suppressing Radar Interference	14	5.7 Relative Bearing Alignment	37
2.18 Suppressing Noise Interference	15	5.8 Sweep Timing	37
2.19 Selecting Pulselength	15	5.9 Closing the Installation Menus	38
2.20 Off Centering the Display	15		
2.21 Echo Trails	16		
2.22 The Navigation Data Display	16		
2.23 Echo Stretch	17		
2.24 Selecting Unit of Measurement for Range	18		

FOREWORD

Congratulations on your choice of the FURUNO MODEL 841 MARK-2 Marine Radar. We are confident you will see why the FURUNO name has become synonymous with quality and reliability.

For over 40 years FURUNO Electric Company has enjoyed an enviable reputation for innovative and dependable marine electronics equipment. This dedication to excellence is furthered by our extensive global network of agents and dealers.

Your radar is designed and constructed to meet the rigorous demands of the marine environment. However, no machine can perform its intended function unless properly installed and maintained. Please carefully read and follow the recommended procedures for installation, operation and maintenance.

While this unit can be installed by the purchaser, any purchaser who has doubts about his or her technical abilities may wish to have the unit installed by a FURUNO representative or other qualified technician. The importance of a thorough installation cannot be overemphasized.

We would appreciate hearing from you, the end-user, about whether we are achieving our purposes.

Thank you for considering and purchasing FURUNO equipment.

Features

Your radar has a large variety of functions, all contained in a remarkably small cabinet.

The main features of the MODEL 841 MARK-2 are:

- Traditional FURUNO reliability and quality in a compact, lightweight and low-cost radar.
- Smartly styled, light-weight and compact radome antenna fits even on small yachts.
- Durable brushless antenna motor.
- High definition 8" LCD raster-scan display.
- On-screen alphanumeric readout of all operational information.
- Standard features include EBL (Electronic Bearing Line), VRM (Variable Range Marker), Guard Alarm, Display Off Center and Echo Trail.
- Watchman feature periodically transmits the radar to check for radar targets which may be entering (or exiting) the alarm zone.
- Operates on 10.2 to 31.2 V DC power supply and consumes about 40 W.
- Ship's position in latitude and longitude (or Loran C Time Differences), range and bearing to a waypoint, ship's speed, heading and course can be shown in the bottom text area. (Requires a navigation aid which can output such data in NMEA 0183 format.)
- Zoom feature provided.

SPECIFICATIONS

Antenna Unit

- 1. Radiator**
Printed array
- 2. Radiator length**
54 cm
- 3. Horizontal beamwidth**
3.9°
- 4. Vertical beamwidth**
20°
- 5. Sidelobe**
-20 dB within main lobe
-23 dB outside main lobe
- 6. Polarization**
Horizontal
- 7. Antenna rotation speed**
24 rpm
- 8. Wind resistance**
Relative wind speed 100 kts (51.5 m/s)

Transceiver Module (contained in radome)

- 1. Transmitting tube**
Magnetron MG5248, E3571 or
MAF1421B
- 2. Frequency**
9410 MHz \pm 30MHz, P0N (X band)
- 3. Peak output power**
4 kW
- 4. Pulselength & pulse repetition rate**
0.08 μ s, 2100 Hz (0.25, 0.5, 0.75, 1,
1.5 nm)
0.3 μ s, 1200 Hz (1.5, 2, 3 nm)
0.8 μ s, 600 Hz (3, 4, 6, 8, 12, 24, 36
nm)
- 5. Warm-up time**
2:30
- 6. Modulator**
FET switching method
- 7. I. F.**
60 MHz
- 8. Tuning**
Automatic or manual

- 9. Receiver front end**
MIC (Microwave IC)
- 10. Bandwidth**
7 MHz
- 11. Duplexer**
Circulator with diode limiter

Display Unit

- 1. Indication system**
PPI raster scan
- 2. Display**
8-inch diagonal LCD, STN semi-
transparent, yellow mode
- 3. Range scales (nm)**
Range, Ring Interval: 0.125(0.0625),
0.25(0.125), 0.5(0.125), 0.75(0.25),
1(0.25), 1.5(0.5), 2(0.5), 3(1), 4(1),
6(2), 8(2), 12(3), 16(4), 24(6), 36 (6)
- 4. Bearing resolution**
4°
- 5. Bearing accuracy**
Better than 1°
- 6. Range discrimination**
Better than 25 m
- 7. Range ring accuracy**
0.9% of range in use or 8 m,
whichever is larger
- 8. Minimum range**
Better than 37 m
- 9. Markers**
Heading marker, Bearing scale, Range
ring, VRM, EBL, Waypoint (option),
Tuning indicator, Alarm zone, Cursor
- 10. Alphanumeric indication**
Standard: Electronic Bearing Line
(EBL), Echo Stretch (ES), Rain
Clutter Rejection (FTC), Alarm
(G), Interference Rejection (IR),

Stand-by (ST-BY), Echo Trail Time (TRAIL), Variable Range Marker (VRM), Range, Range Ring Interval, Range and Bearing to Cursor (+), Off Center (OFF CENTER), Watchman (WATCHMAN)

With navigation input (option): Course (CRS), Latitude and longitude, Speed (SPD), Range and bearing to waypoint (WP), Cross Track Error (XTE), Date and time, Water depth, Water temperature. *(This radar has only two data input ports. To receive data from more than two equipment install an mixing device.)*

11. Vibration

<u>Vibration freq.</u>	<u>Total amplitude</u>
5 to 12.5 Hz	±1.6 mm
12 to 25 Hz	±0.35 mm
25 to 50 Hz	±0.10 mm

12. Ambient temperature

Antenna unit: -20°C to +70°C
 Display unit: 0°C to +60°C
Due to the inherent nature of the LCD its contrast may be affected under ambient temperature below 0°C (32°F) or above 50°C (122°F).

13. Humidity

Relative humidity 95% or less at +40°C

14. Waterproofing

Display unit: IEC Pub no. 529 IPX5
 Antenna unit: IEC Pub no. 945 class X

15. Power supply & power consumption

12 V or 24V(10.2 V to 31.2 V DC),
 40 W approx.

16. Protection features

Protection against reverse polarity, overvoltage, overcurrent, and internal fault

17. Compass safe distance

Unit	Standard compass	Steering compass
Display	0.7 m	0.5 m
Antenna	0.9 m	0.7 m

Interface NMEA

Input

Own ship's position : RMA>RMC>GLL
 (GLL is available Ver.5 and after.)

Speed : RMA>RMC>VTG>VHW

Heading(True):
 HDT>VHW>HDG>VHW>HDM

Heading (Magnetic):
 HDM>VHW>HDG>VHW>HDM

Course (True):
 RMA>RMC>VTG

Course (Magnetic)
 VTG>RMA>RMC

Waypoint (L/L, Range, Bearing):
 RMB>BWC>BWR

Loran time difference :
 RMA>GLC>GTD

Water depth : DPT>DBK, DBS, DBT

Water temperature : MDA>MTW

Time : ZDA

XTE : RMB>XTE>APB

Output

TLL : On using "HM OFF" key.

RSD : A cycle of four seconds

EQUIPMENT LIST

Complete Set

No.	Name	Type	Code No.	Qty	Remarks
1	Antenna unit	RSB-0071-058		1	
2	Display unit	RDP-113-4 M2		1	
3	Spare parts	SP03-09800	000-085-441	1 set	
4	Accessories	FP03-05900	008-462-050	1 set	
5	Installation materials (select one)	CP03-18100	000-086-972	1 set	Signal cable: 10 m
		CP03-18110	000-086-973		Signal cable: 15 m
		CP03-18120	000-086-974		Signal cable: 20 m
		CP03-18130	000-086-975		Signal cable: 30 m

Installation Materials (CP03-15xx)

No.	Name	Type	Code No.	Qty	Remarks
1	Hex Bolt	M10x25 SUS304	000-862-308	4	
2	Flat Washer	M10 SUS304	000-864-131	4	
3	Spring Washer	M10 SUS304	000-864-261	4	
4	XH Connector	03-1796(5P)	008-462-830	1	
5	Signal cable* (Select one)	S03-72-10	008-475-340	1	10 m
		S03-72-15	008-475-350		15 m
		S03-72-20	008-475-360		20 m
		S03-72-30	008-475-370		30 m
6	Power cable	03S9148-0	000-129-613	1	3.5m

*S03-61 compatible may be supplied; two thin pink wires replaced with one thick wire.

Spare Parts (SP03-9800)

No.	Name	Type	Code No.	Qty	Remarks
1	Fuse	FGBO-A 5A AC125 V	000-549-064	2	

Accessories (FP03-05900)

No.	Name	Type	Code No.	Qty	Remarks
1	Tapping Screw	5x20 SUS304	000-802-081	4	

Optional Equipment

No.	Name	Type	Code No.	Qty	Remarks
1	Rectifier	PR-62	000-013-484	1	100 VAC
			000-013-485		110 VAC
			000-013-486		220 VAC
			000-013-487		230 VAC
2	External Buzzer	OP03-136	000-086-443	1	
3	Mounting Bracket (1)	OP03-92	000-445-070	1	For sailboat

CONFIGURATION

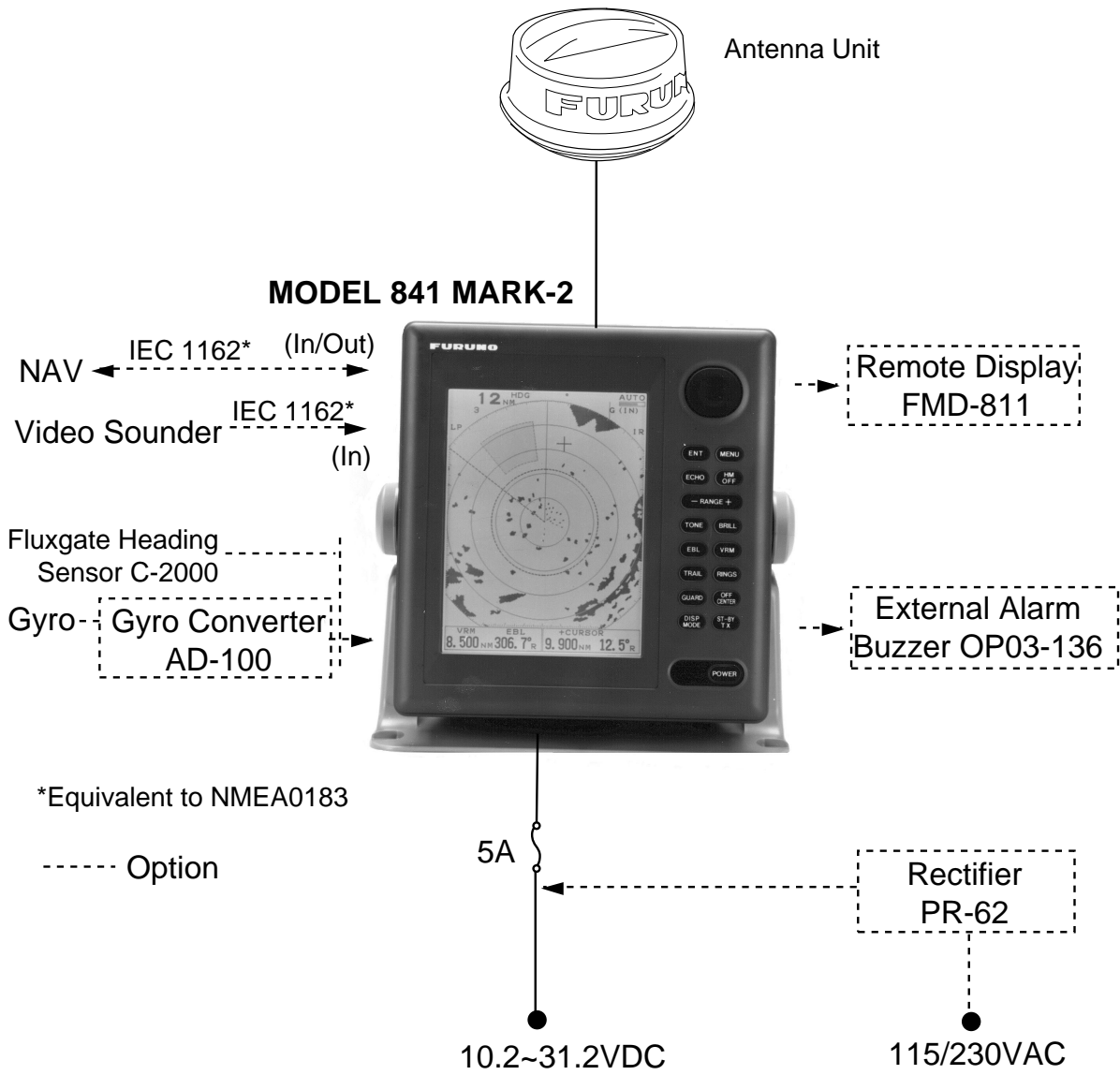

1. PRINCIPLE OF OPERATION

1.1 What is Radar?

The term "RADAR" is an acronym meaning RAdio Detection And Ranging. Although the basic principles of radar were developed during World War II, primarily by scientists in Great Britain and the United States, the use of echoes as an aid to navigation is not a new development.

1.2 How Ships Determined Position Before Radar

Before the invention of radar, when running in fog near a rugged shoreline, ships would sound a short blast on their whistles, fire a shot, or strike a bell. The time between the origination of the sound and the returning of the echo indicated how far the ship was from the cliffs or the shore. The direction from which the echo was heard indicated the relative bearing of the shore.

1.3 How Radar Determines Range

Radar determines the distance to the target by calculating the time difference between the transmission of a radar signal and the reception of the reflected echo. It is a known fact that radar waves travel at a nearly constant speed of 162,000 nautical miles per second. Therefore the time required for a transmitted signal to travel to the target and return as an echo to the source is a measure of the distance to the target. Note that the echo makes a complete round trip, but only half the time of travel is needed to determine the one-way distance to the target. This radar automatically takes this into account in making the range calculation.

1.4 How Radar Determines Bearing

The bearing to a target found by the radar is determined by the direction in which the radar scanner antenna is pointing when it emits an electronic pulse and then receives a returning echo. Each time the scanner rotates pulses are transmitted in the full 360 degree circle, each pulse at a slightly different bearing from the previous one. Therefore, if one knows the direction in which the signal is sent out, one knows the direction from which the echo must return.

1.5 Radar Wave Speed and Antenna Rotation Speed

Note that the speed of the radar waves out to the target and back again as echoes is extremely fast compared to the speed of rotation of the antenna. By the time radar echoes have returned to the scanner, the amount of scanner rotation after initial transmission of the radar pulse is extremely small.

1.6 The Radar Display

The range and bearing of a target is displayed on what is called a Plan Position Indicator (PPI). This display is essentially a polar diagram, with the transmitting ship's position at the center. Images of target echoes are received and displayed at their relative bearings, and at their distance from the PPI center.

With a continuous display of the images of targets, the motion of the transmitting ship is also displayed.

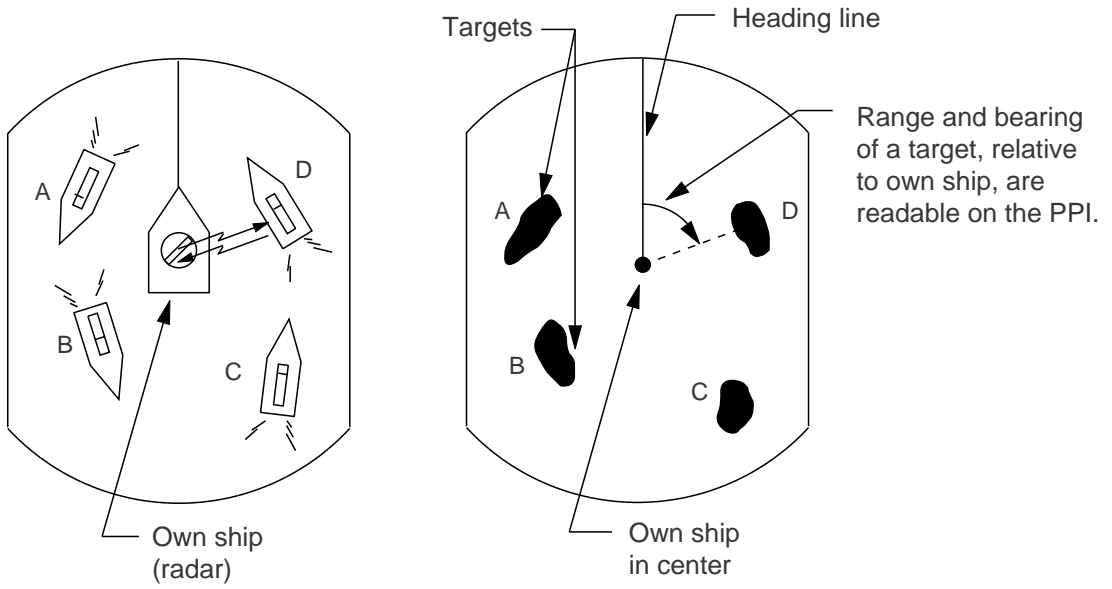

(A) Bird's eye view of situation

(B) Radar picture of (A)

Figure 1-1 How radar works

2. OPERATION

2.1 Control Description

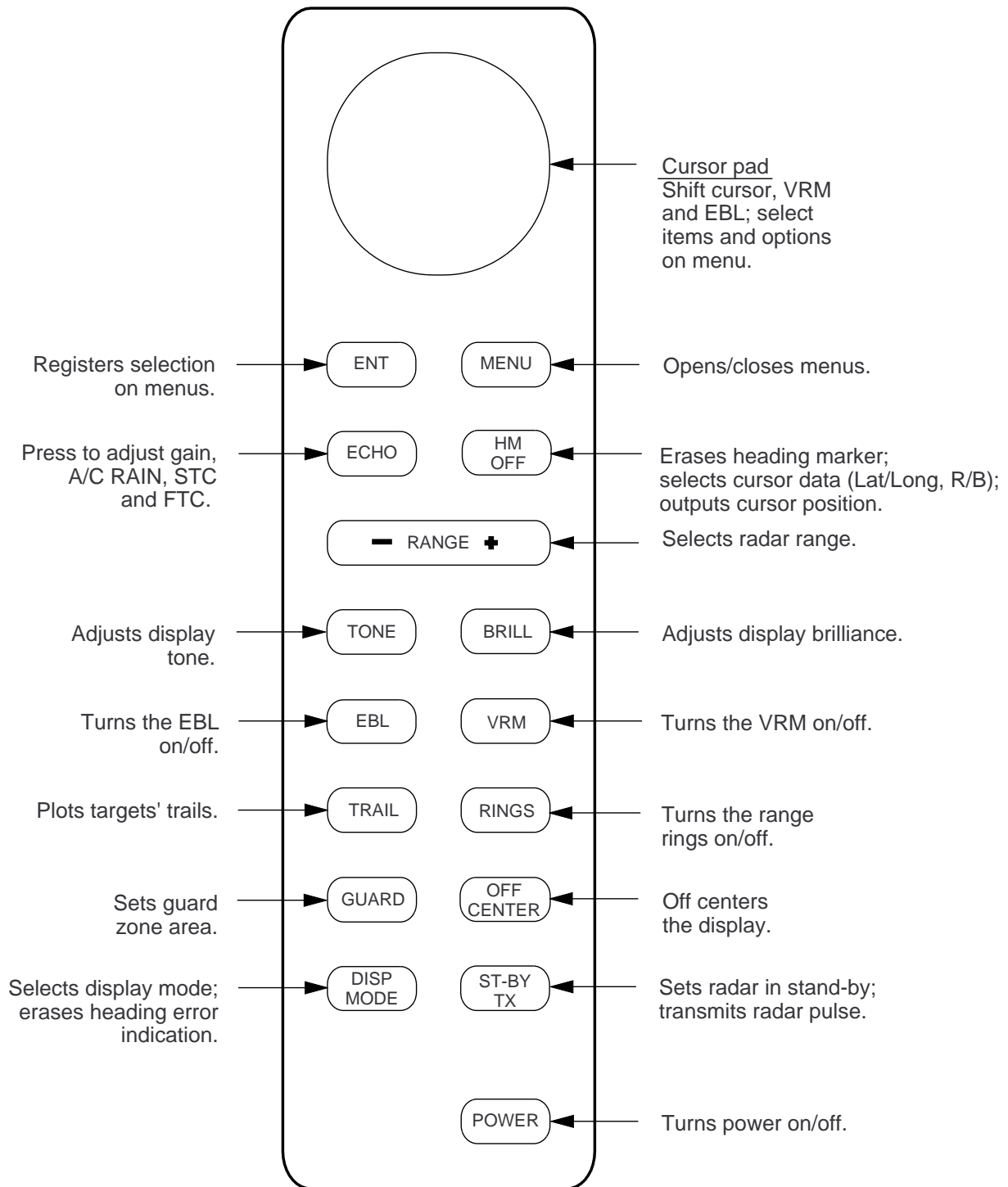

Figure 2-1 Control panel

2.2 Display Indications and Markers

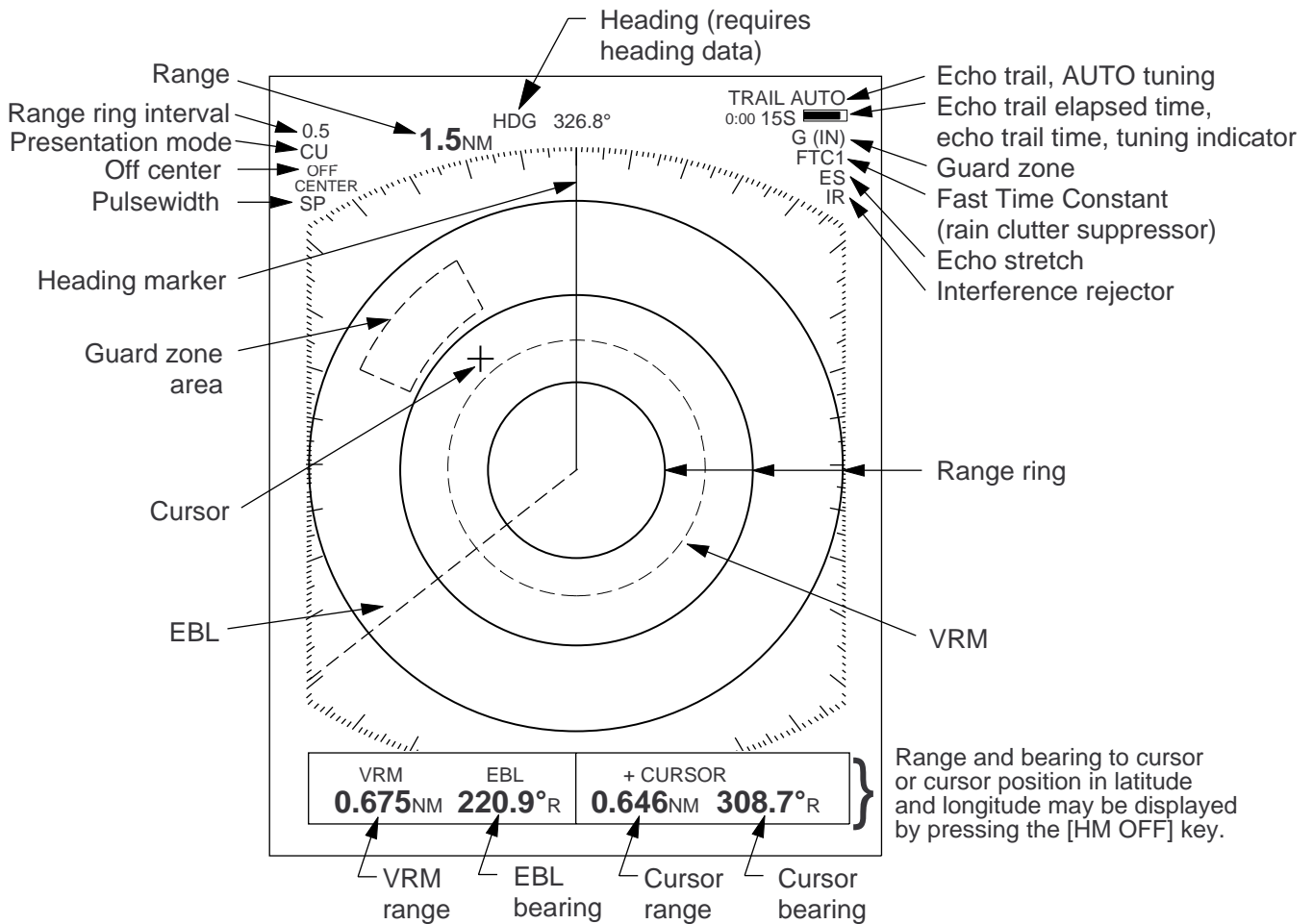

Figure 2-2 Display indications

2.3 Turning the Radar On and Off

Turning the radar on

Press the [POWER] key to turn the radar on or off. The control panel lights and a timer displays the time remaining for warm up of the magnetron (the device which produces radar pulses), counting down from 2:30 to 0:01.

Note: When the power is reapplied within a certain amount of time and circuits remain charged, the warmup process is skipped—you can transmit immediately.

CAUTION

The radar antenna emits high frequency radio radiation which can be harmful, particularly to your eyes. Never look directly at the antenna from a distance of less than two feet when the radar is in operation. Always make sure no one is near the antenna before turning on the radar.

Note: When the heading signal is lost, the HDG readout at the top of the screen shows ***. This warning stays on when the heading signal is restored to warn the operator that the readout may be unreliable. The warning may be erased by pressing the [DISP MODE] key,

2.4 Transmitting

After the power is turned on and the magnetron has warmed up, ST-BY (Stand-By) appears at the screen center. This means the radar is now fully operational. In stand-by the radar is available for use at anytime—but no radar waves are being transmitted.

Press the [ST-BY TX] key to transmit. When transmitting, any echoes from targets appear on the display. This radar displays echoes in four tones of gray according to echo strength.

When you won't be using the radar for an extended period but want to keep it in a state of readiness, press the [ST-BY TX] key to set the radar in stand-by.

2.5 Selecting the Range

The range selected automatically determines the range ring interval, the number of range rings, pulselength and pulse repetition rate, for optimal detection capability in short to long ranges.

Procedure

Press the [- RANGE +] key. The range and range ring interval appear at the top left corner on the display.

Tips for selecting the range

- When navigating in or around crowded harbors, select a short range to watch for possible collision situations.
- If you select a lower range while on open water, increase the range occasionally to watch for vessels that may be heading your way.

2.6 Adjusting LCD Backlighting and Display Tone

The [BRILL] key adjusts the LCD backlighting in eight levels, including off. The [TONE] key adjusts the tone (contrast) of the display in 32 levels, including off.

Procedure

- 1) Press the [BRILL] key (or [TONE] key). The display shown in Figure 2-3 appears.

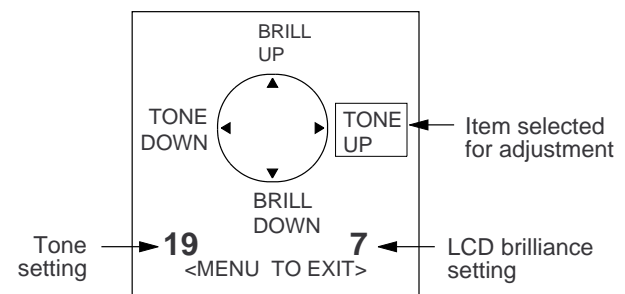

Figure 2-3 Display for adjustment of brilliance and tone

- 2) Press the [BRILL] key (or [TONE] key) to set level. For fine adjustment, press cursor pad at 12 o'clock/6 o'clock for brilliance and 3 o'clock/9 o'clock for tone.

2.7 Adjusting Control Panel Brilliance

Procedure

- 1) Press the [MENU] key.
- 2) Press the cursor pad to select Backlight/Brilliance and press the [ENT] key.
- 3) Press the cursor pad to select Panel.
- 4) Press the cursor pad to select brilliance level; 4 is the highest.
- 5) Press the [ENT] key followed by the [MENU] key.

2.8 Adjusting GAIN, STC, A/C RAIN and FTC

General procedure

The [ECHO] key enables adjustment of the gain, STC, A/C RAIN and FTC.

- 1) Press the [ECHO] key. The following display appears.

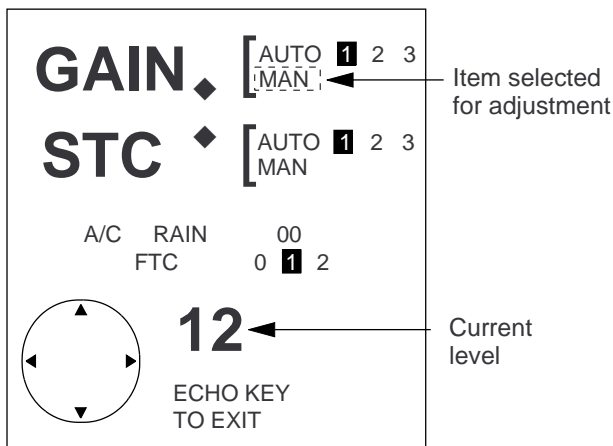

Figure 2-4 Display for adjustment of GAIN, STC, A/C RAIN and FTC

- 2) Press the cursor pad to select item to adjust. Current selection is circumscribed by dashed rectangle.
- 3) Press [ENT].
- 3) Press the cursor pad to set level.
- 4) Press the [ECHO] key to finish.

How to adjust the gain (sensitivity)

The gain works in precisely the same manner as the volume control of a broadcast receiver, amplifying the signals received.

You can adjust the gain automatically or manually. For manual adjustment, adjust the sensitivity on the highest range—the background noise is clearer on that range. The proper setting is such that the background noise is just visible on the screen. If you set up for too little gain, weak echoes may be missed. On the contrary excessive gain yields too much background noise; strong targets may be missed because of the poor contrast between desired echoes and the background noise on the display.

How to adjust STC (suppressing sea clutter)

Echoes from waves can be troublesome, covering the central part of the display with random signals known as sea clutter. The higher the waves, and the higher the scanner above the water, the further the clutter will extend. Sea clutter appears on the display as many small echoes which might affect radar performance. (See the left-hand figure in Figure 2-5).

The STC reduces the amplification of echoes at short ranges (where clutter is the greatest) and progressively increases amplification as the range increases, so amplification will be normal at those ranges where there is no sea clutter. The control is effective up to about 4 miles.

STC can be adjusted automatically or manually. For manual adjustment, first adjust the gain and then transmit on short range. Adjust the STC level such that the clutter is broken up into small dots, and small targets become distinguishable. If the setting is set too low, targets will be hidden in the clutter, while if it is set too high, both sea clutter and targets will disappear from the display. In most cases adjust so clutter has disappeared to leeward, but a little is still visible windward.

If there is no clutter visible on the display, turn off the circuit.

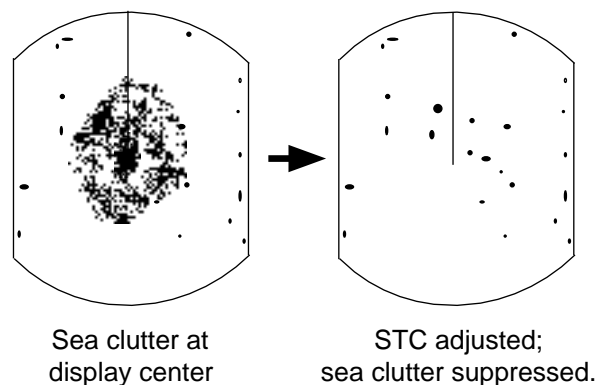

Figure 2-5 Effect of STC

How to adjust A/C RAIN and FTC (suppressing rain clutter)

The vertical beamwidth of the scanner is designed to see surface targets even when the ship is rolling. However, by this design the unit will also detect rain clutter (rain, snow, hail, etc.) in the same manner as normal targets. Figure 2-6 shows the appearance of rain clutter on the display.

Adjusting A/C RAIN

When rain clutter masks echoes over a wide range, raise the A/C RAIN slightly to distinguish targets from the clutter.

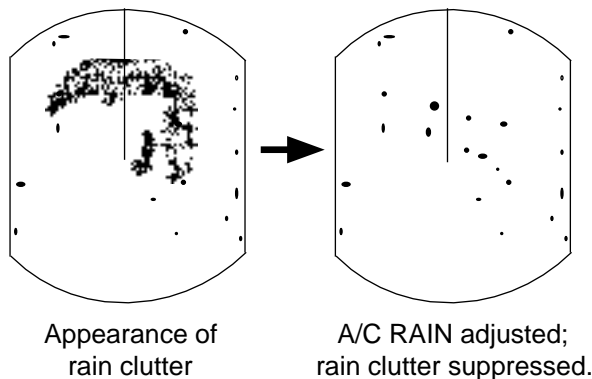

Figure 2-6 Effect of A/C RAIN

Adjusting FTC

To suppress rain clutter from heavy storms or scattered rain clutter, adjust the FTC. The FTC circuit splits up these unwanted echoes into a speckled pattern, making recognition of solid targets easier. FTC and selected level appear at the top right-hand corner of the display when the circuit is turned on.

Note: In addition to reducing clutter, the FTC can be used in fine weather to clarify the picture when navigating in confined waters. However, with the circuit activated the receiver is less sensitive. Therefore, turn off the circuit when its function is not required.

2.9 Tuning the Receiver

The receiver can be tuned automatically or manually. For automatic tuning the receiver is tuned each time you switch from stand-by to transmit. For manual tuning, the receiver is properly tuned when the longest tuning indicator appears. (However, the length of the indicator changes with the number of radar echoes, range and other factors.)

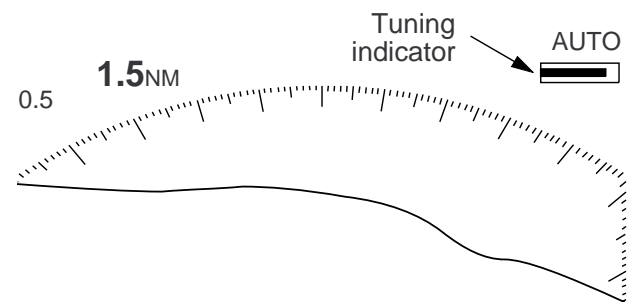

Figure 2-7 Tuning indicator

Manual tuning

The default tuning method is automatic. To switch to manual tuning;

- 1) Press the [MENU] key to open the menu.
- 2) Press the cursor pad to select Tuning.
- 3) Press the cursor pad to select MANUAL.
- 4) Press the [ENT] key followed by the [MENU] key.

How to tune manually

While pressing and holding down the [HM OFF] key, press the 9 o'clock or 3 o'clock position on the cursor pad to tune. Tune to show the longest tuning indicator.

2.10 Measuring the Range

You can measure the range to a target three ways: by the range rings, by the cursor, and by the VRM (Variable Range Marker).

By range rings

Press the [RINGS] key to display the range rings. Count the number of rings between the center of the display and the target. Check the range ring interval (at the top left corner) and judge the distance of the echo from the inner edge of the nearest ring.

By cursor

Operate the cursor pad to place the cursor intersection on the inside edge of the target echo. The range to the target, as well as the bearing, appears at the bottom of the display.

By VRM

- 1) Press the [VRM] key to display the VRM.
- 2) Press the cursor pad to place the VRM on the inside edge of the target. (The cursor appears and is linked with the VRM, allowing you to measure both range and bearing to the target.)
- 3) Check the VRM readout at the bottom left-hand corner of the display to find the range to the target.

Note: The VRM is automatically anchored when no cursor pad key is operated within about 10 seconds.

To erase the VRM, press and hold down the [VRM] key for about three seconds.

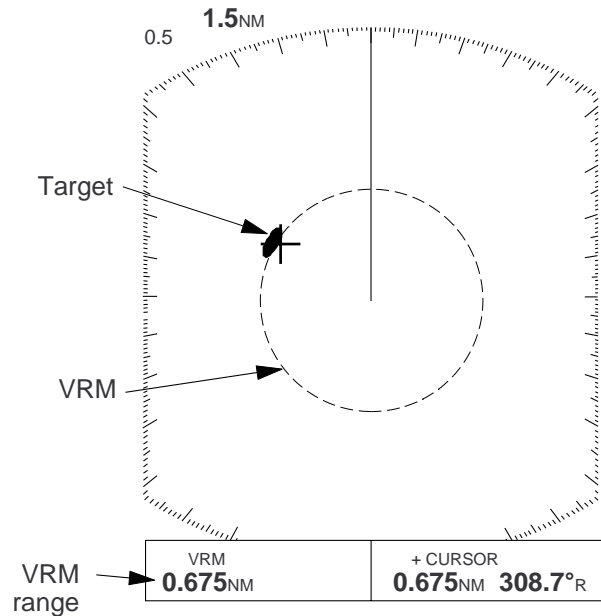

Figure 2-8 Measuring range by the VRM

2.11 Measuring the Bearing

There are two ways to measure the bearing to a target: by the cursor, and by the EBL (Electronic Bearing Line).

By cursor

Operate the cursor pad to bisect the target with the cursor intersection. The bearing to the target appears at the bottom right-hand corner of the display.

By EBL

- 1) Press the [EBL] key to display the EBL.
- 2) Press the cursor pad to bisect the target with the EBL. (The cursor appears and is linked with the EBL, allowing you to measure both bearing and range to the target.)
- 3) Check the EBL readout at the bottom left-hand corner of the display to find the bearing to the target.

Note: The EBL is automatically anchored when no cursor pad key is operated within about 10 seconds.

To erase the EBL, press and hold down the [EBL] key for about three seconds.

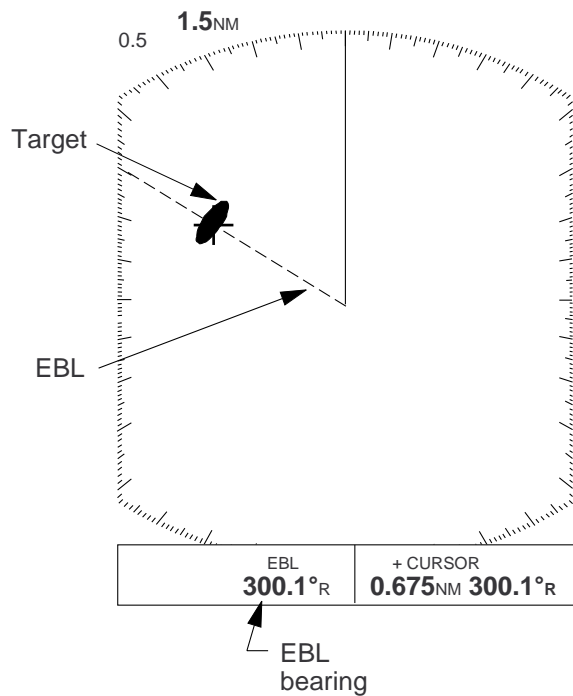

Figure 2-9 Measuring bearing by the EBL

Tips for measuring the bearing

- Bearing measurements of smaller targets are more accurate; the center of larger target echoes is not as easily identified.
- Bearings of stationary or slower moving targets are more accurate than bearings of faster moving targets.
- To minimize bearing errors keep echoes in the outer half of the picture by changing the range scale; angular difference becomes difficult to resolve as a target approaches the center of the display.

Target on collision course with your vessel?

You can determine if a target might be on a collision course with your vessel by placing the EBL on the target. If it tracks along the EBL as it approaches the screen center it may be on a collision course with your vessel.

2.12 Menu Operation

The menu, consisting of 6 sub menus, mostly contains less-often used functions which once preset do not require regular adjustment. To open or close the menu, press the [MENU] key. You can select items on the menu with the cursor pad.

Basic menu operation

- 1) Press the [MENU] key to open the menu.
The main menu appears.

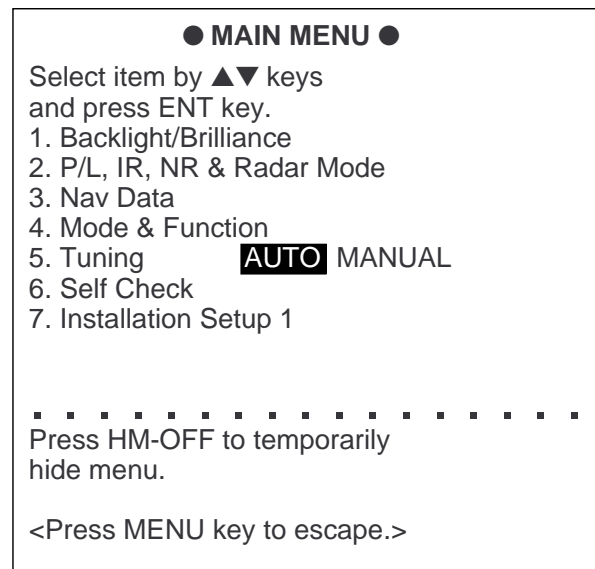

Figure 2-10 Main menu

- 2) Press the cursor pad to select menu and press the [ENT] key.
- 3) Press the cursor pad to select menu item.
- 4) Press the cursor pad to select option.
- 5) Press the [ENT] key to register selection.
- 6) Press the [MENU] key to close the menu.

Menu description

See the table on the next page.

Table 1-1 Menu description

Menu	Function
<p>1. BACKLIGHT/BRILLIANCE MENU</p> <p>Select item and option by ▲▼ keys.</p> <p>1. Panel 1 2 3 4 2. Echo Trails 1 2</p> <p>.....</p> <p>Press HM-OFF to temporarily hide menu.</p> <p><Press MENU for main menu.></p>	<p>1. Selects control panel backlighting; four is maximum backlighting.</p> <p>2. Selects brilliance for echo trails and markers; four is maximum brilliance.</p>
<p>2. P/L, IR, NR & Radar Mode</p> <p>Select item and option by ▲▼ keys.</p> <p>1. Pulselength SHORT LONG 2. Int Reject OFF 1 2 3 3. Noise Reject OFF ON 4. Echo Stretch OFF ON 5. Radar mode CU WPT-UP</p> <p>.....</p> <p>Press HM-OFF to temporarily hide menu.</p> <p><Press MENU for main menu.></p>	<p>1. Selects pulselength for 1.5 and 3 mile ranges.</p> <p>2. Selects radar interference rejector level; 3 provides highest degree of rejection.</p> <p>3. Turns noise rejector on/off.</p> <p>4. Turns echo stretch on/off.</p> <p>5. Select mode for CU or WPT-UP.</p>
<p>3. NAV DATA MENU</p> <p>Select item and option by ▲▼ keys.</p> <p>1. Navigator ALL GPS LC 2. Nav Data Disp OFF ON 3. Pos Disp Mode L/L TD 4. Depth Unit M FA FT 5. Temp Unit °C °F 6. STBY Display NORM NAV</p> <p>.....</p> <p>Press HM-OFF to temporarily hide menu.</p> <p><Press MENU for main menu.></p>	<p>1. Selects navigator among GPS, Loran and all navigators available. In the "All" setting the radar selects a navigator in order of navigator accuracy—GPS, Loran and other.</p> <p>2. Turns navigation data display on/off.</p> <p>3. Selects position display format; latitude and longitude or Loran TDs.</p> <p>4. Selects unit of measurement for depth; meters, feet or fathoms.</p> <p>5. Selects unit of measurement for water temperature; °C or °F.</p> <p>6. Selects what to display during stand-by; navigation data (requires navigation input) or "STBY".</p>
<p>4. MODE & FUNCTION MENU</p> <p>Select item and option by ▲▼ keys.</p> <p>1. Window Display ZOOM WIDE 2. Watchman OFF 5' 10' 20' 3. Alarm Mode IN OUT 4. VRM Unit NM KM SM 5. EBL Ref REL TRUE 6. Range 1/8 1/4 1/2 3/4 1 1/5 2 3 4 8 12 16 24 *36</p> <p>.....</p> <p>Press HM-OFF to temporarily hide menu.</p> <p><Press MENU for main menu.></p>	<p>1. Selects window display format; zoom or wide.</p> <p>2. Selects watchman interval among 5 min, 10 min or 20 min.</p> <p>3. Selects alarm mode; IN (alarm to targets entering the guard zone, or OUT (alarm to targets exiting the guard zone).</p> <p>4. Selects VRM unit; nm, km or sm.</p> <p>5. Selects EBL reference; relative or true.</p> <p>6. Selects ranges to use. Select range to enable (disable) and press [ENT] key.</p> <p>* Model 841 only</p>
<p>Tuning</p>	<p>Selects AUTOMATIC or MANUAL tuning.</p>
<p>Self Check</p>	<p>Checks the radar system for proper operation.</p>

* Default settings shown in boldface.

2.13 Selecting the Display Mode

The display mode may be selected with the [DISP MODE] key. Four modes are available (with navigation input): Normal, Normal + Window, Normal + Nav Data, and Normal + Window + Nav Data.

Each time the key is pressed the display mode changes in one of the sequences shown below, depending on equipment connected and menu settings.

Note: In the window display mode, the [DISP MODE] key reselects zoom area. To select the display mode while in the window display mode, press the key twice.

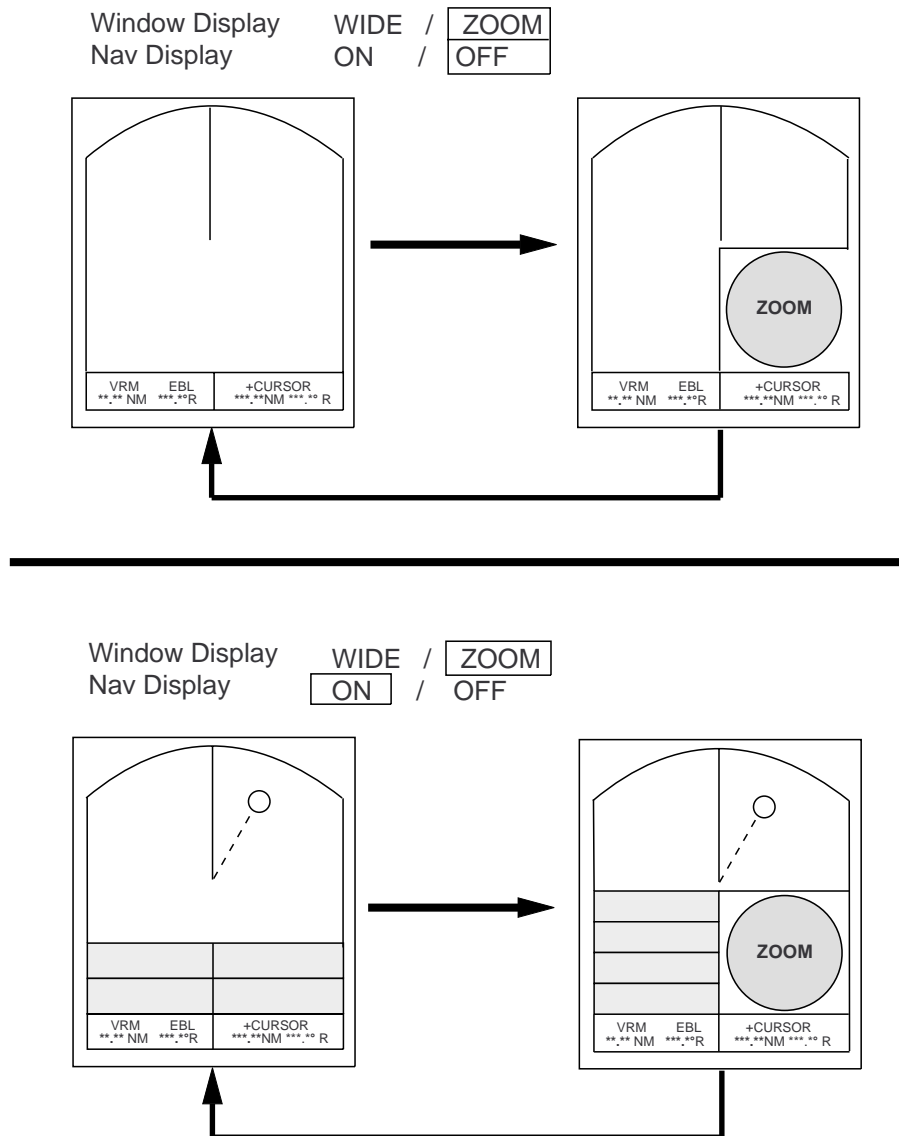

Figure 2-11 Display modes

2.14 The Window Display

The window display appears at the bottom right (or left) 1/4 of the display. Two types of window displays are available: zoom and wide. Zoom doubles the size of the area selected by the operator, and wide (range-up) compresses and displays the entire radar picture on the next higher range.

Note: The zoom display does not function on the 0.125 and 0.25 nm ranges.

Selecting the type of window display

- 1) Press the [MENU] key.
- 2) Select Mode & Function and press the [ENT] key.

Note: When you place the circle cursor behind the window display, the window display shifts left (or right) so you may view the circle cursor.
- 3) Select Window Display to Zoom or Wide (range-up).
- 4) Press the [ENT] key followed by the [MENU] key.

Selecting the area for the zoom picture

- 1) Press the [DISP MODE] key to select the window display. The area selector is a solid circle.
- 2) Press the cursor pad to place the circle cursor (area selector) on the area to zoom.
- 3) Press the [ENT] key. The area selector becomes a dashed circle and the cursor can be moved independently.

To reselect area to zoom, press [ENT] or [DISP MODE] and follow steps 2 and 3.

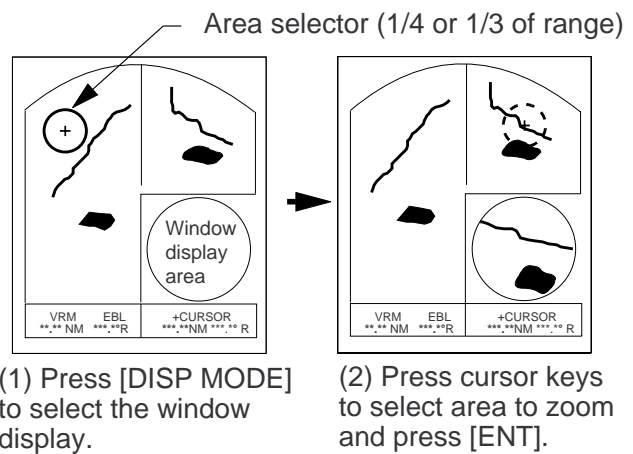
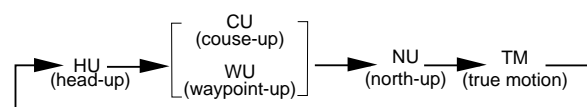

Figure 2-12 How to select the area to zoom

2.15 Selecting the Presentation Mode

This radar provides four presentation modes: head-up, course-up (course-up or waypoint-up; selectable on menu), north-up and true motion. Press the [DISP MODE] and [HM OFF] keys together to select a presentation mode. Each time the keys are pressed, if heading signal is input to the radar, the presentation mode and mode indication change in the sequence of HU, CU (or WU), NU, TM. If there is no heading signal input to the radar, the presentation mode is always HU.



Selecting course-up mode for CU or WPT-UP

In course-up, you may select CU or WPT-UP, on the menu.

CU (course-up)

An azimuth stabilized display in which the line connecting the center with the top of the display indicates own ship's intended course.

WPT-UP (waypoint-up)

An azimuth stabilized display in which the line connecting the center with the top of the display indicates the bearing to the “TO” waypoint, which is selected on the navigational equipment connected to the radar. When navigating a route and own ship enters the arrival zone of a waypoint, the radar displays the bearing to the next “TO” waypoint.

Procedure

1. Press the [MENU] key to open the menu.
2. Press the cursor pad to select 2. P/L, IR, NR & Radar Mode.
3. Press the cursor pad to select Radar mode.
4. Select option for CU or WPT-UP.
5. Press the [ENT] key followed by the [MENU] key.

NOTE:

Insert display example and description for each presentation mode, like in FR-1500M2 or FR-8000 series'. Also, add section on how display is reset in true motion and change Table of Contents if necessary.

2.16 Guard Alarm

The guard alarm allows the operator to set the desired range and bearing for a guard zone. When ships, islands, landmasses, etc. enter (or exit, depending on type of guard zone in use.) the guard zone an audible alarm sounds to call the operator’s attention. The alarm is very effective as an anticollision aid when using an autopilot or navigating in narrow channels.



CAUTION

The guard alarm is a useful anti-collision aid, but does not relieve the operator of the responsibility to also keep a visual lookout for possible collision situations. The alarm should never be used as the sole means for detecting possible collision situations.

The guard alarm can be set to sound on targets entering (guard in) or exiting (guard out) the guard zone. Select type of guard zone as follows.

- 1) Press the [MENU] key to display the menu.
- 2) Select Mode & Function and press the [ENT] key.
- 3) Select Alarm Mode to IN or OUT.
- 4) Press the [ENT] key followed by the [MENU] key.

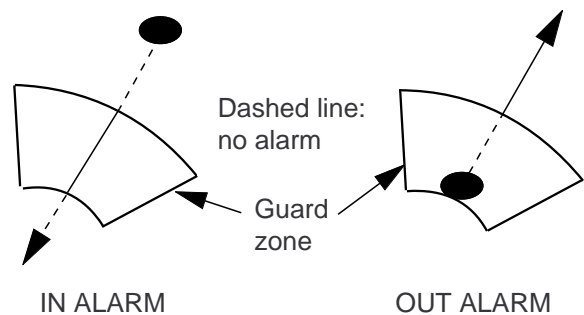

Figure 2-13 In and out alarms

Setting the guard zone

- 1) Mentally create the guard zone you want to display. See Figure 2-14 (1).
- 2) Operate the cursor pad to set cursor on top (bottom) left edge of the guard zone. Press the [GUARD] key. *G (IN) (or G OUT)), with asterisk blinking, appears at the top right-hand corner on the display. (The asterisk indicates the guard zone is partially set.) See Figure 2-14 (2).
- 3) Operate the cursor pad to set cursor on bottom (top) right edge of the guard zone and press the [GUARD] key. The asterisk disappears. See Figure 2-14 (3).
- 4) Guard zone appears on the display. See Figure 2-14 (4).

Silencing the audible alarm

Any ships, landmasses, etc. coming into (or going out of) the guard zone will trigger the audible alarm and display the guard zone in reverse video. You can silence the alarm by

pressing the [GUARD] key. When this is done, G (ACKN) replaces G (IN) (or G (OUT)).

Press the [GUARD] key again to reactivate the alarm. G (IN) (or G (OUT)) replaces G (ACKN).

Canceling the guard zone

Press and hold down the [GUARD] key until the guard zone disappears.

Notes on the guard alarm

- When the radar range is less than one half of the guard zone range, the guard zone disappears from the display and UP RANGE appears. If this happens, raise the range to redisplay the guard zone.
- A target echo does not always mean a landmass, reef, ships or surface objects but can imply returns from sea surface or precipitation. As the level of these returns

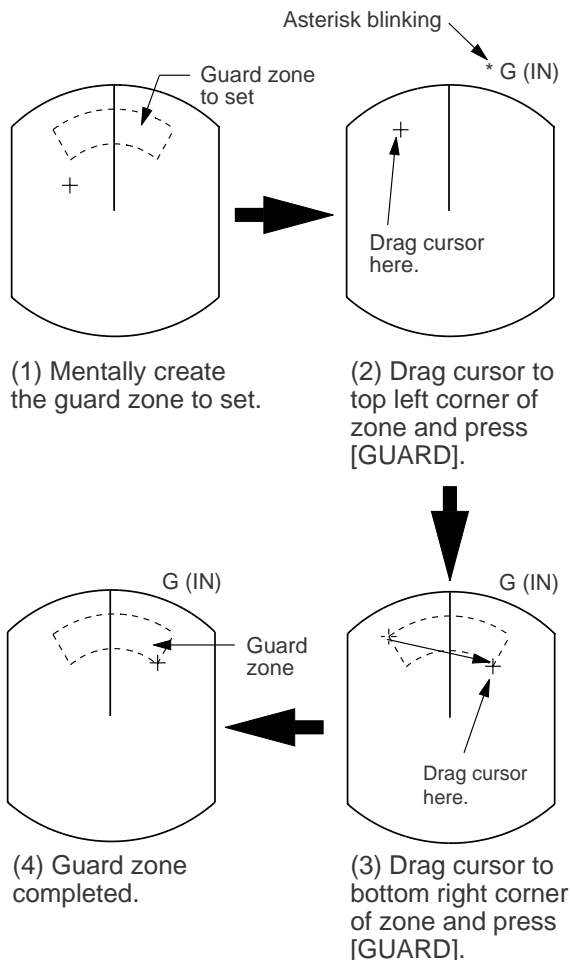

Figure 2-14 How to set a guard zone

varies with environment, the operator should properly adjust the STC, gain (sensitivity), A/C RAIN and FTC to be sure the alarm system does not overlook target echoes.

2.17 Suppressing Radar Interference

Radar interference may occur when near another shipborne radar operating in the same frequency band as your radar. Its on-screen appearance is many bright dots either scattered at random or in the form of dotted lines extending from the center to the edge of the display. Figure 2-15 illustrates interference in the form of curved spokes. Interference effects are distinguishable from normal echoes because they do not appear in the same place on successive rotations of the scanner.

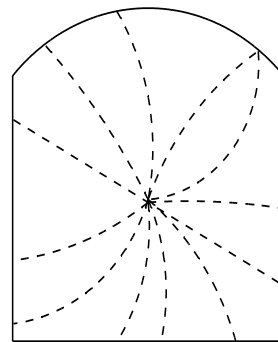

Figure 2-15 Radar interference

Four levels of interference are available, including off: IR1, IR2, IR3 and OFF. IR3 provides the highest level of rejection.

Procedure

- 1) Press the [MENU] key.
- 2) Select P/L & Int/Noise Rej & ES and press the [ENT] key.
- 3) Select INT REJECT.
- 4) Select level desired; 2 provides the greatest degree of interference rejection
- 4) Press [ENT] and [MENU].

IR and level selected appear at the top right

corner on the display when the interference rejection circuit is turned on.

2.18 Suppressing Noise Interference

Noise interference appears on the screen as many bright dots. These dots can be suppressed by turning on the noise rejector. Note however that there are some forms of noise interference which this radar cannot suppress.

Procedure

- 1) Press the [MENU] key.
- 2) Select P/L & Int/Noise Rej & ES and press the [ENT] key.
- 3) Select Noise Reject to ON.
- 4) Press the [ENT] key followed by the [MENU] key.

2.19 Selecting Pulselength

Pulselength is the transmission time of a single radar pulse. The longer the pulselength the greater the detection range capability, however range accuracy and range resolution are reduced.

Pulselength can be selected to short or long on the 1.5 and 3 nautical mile ranges.

- 1) Press the [MENU] key.
- 2) Select P/L & Int/Noise Rej & ES and press the [ENT] key.
- 3) Select Pulselength to SHORT or LONG
- 6) Press [ENT] and [MENU] key.

2.20 Off Centering the Display

Your vessel's position can be shifted anywhere within 75% of the effective display area. The primary advantage of the off centered display is that for any range setting, the view ahead of your vessel can be extended without changing the range or size of targets.

Procedure

- 1) Locate the cursor where you want to the screen center to be.
- 2) Press the [OFF CENTER] key.

OFF CENTER appears at the top left corner on the display when the display is off centered.

Note: The off centered display is automatically canceled when the [DISP MODE] key is pressed.

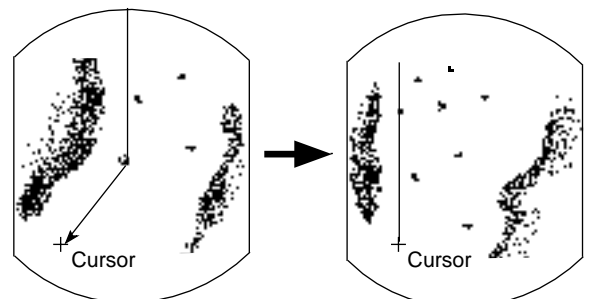

(1) Place cursor where desired.

(2) Press [OFF CENTER] key; cursor location becomes screen center.

Figure 2-16 Off centering the display

2.21 Echo Trails

You can show the trails of targets in afterglow. This function is useful for alerting you to possible collision situations.

Starting echo trail

Press the [TRAIL] key to start the echo trail function. Afterglow starts extending from targets and "TRAIL" and the echo trail time appear at the top right-hand corner of the display. Press the key again within 3 seconds to select a different trail time, among 15 sec, 30 sec, 1 min, 3min, 6 min, 15 min, 30 min, and continuous. In continuous plotting the time elapsed appears at the top right corner on the display.

Note: If the range is changed, trails are painted anew with the newly selected range.

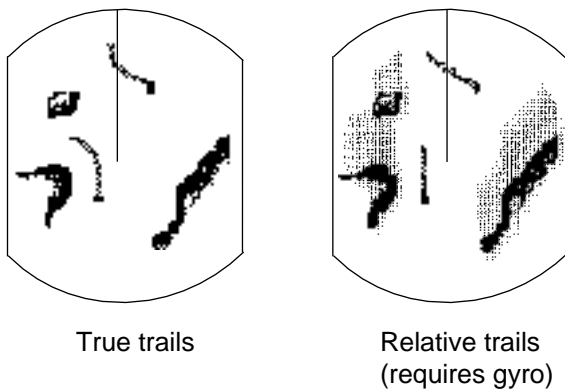

Figure 2-17 Appearance of echo trails

Fixed time trails

When the elapsed time clock counts up to the trail time selected, the elapsed time display freezes. The oldest portions of trails are erased so only the latest trail, equal in length to the trail time selected, is shown. Then, trails start extending again. For example, the one minute trail time is selected. When the elapsed time display freezes at 60 seconds, all but the latest one minute of trails are erased and then trailing continues.

Continuous trail

The maximum continuous trail time is 99

minutes and 59 seconds. When the elapsed time clock counts up to that time the elapsed time display is reset to zero all trails are erased and then trailing is restarted.

Adjusting brilliance of afterglow

The brilliance of the trails' afterglow can be set on the Backlight/Brilliance menu.

- 1) Press the [MENU] key.
- 2) Select Backlight/Brilliance and press the [ENT] key.
- 3) Select Echo Trails.
- 4) Select brilliance.
- 5) Press the [ENT] key followed by the [MENU] key.

Canceling echo trails

Press the [TRAIL] key to erase the TRAIL indication.

2.22 The Navigation Data Display

Navigation data can be displayed at the screen bottom if this radar receives navigation input in NMEA 0183 format. Navigation data includes

- position in latitude and longitude or Loran-C time differences (TDs)
- bearing and range to a waypoint selected on the navigator
- cross track error (XTE—the amount in nautical miles and the direction the vessel is off course)
- depth
- speed.

If the navigation data include the destination data, waypoint position is denoted on the radar display by a dashed ring.

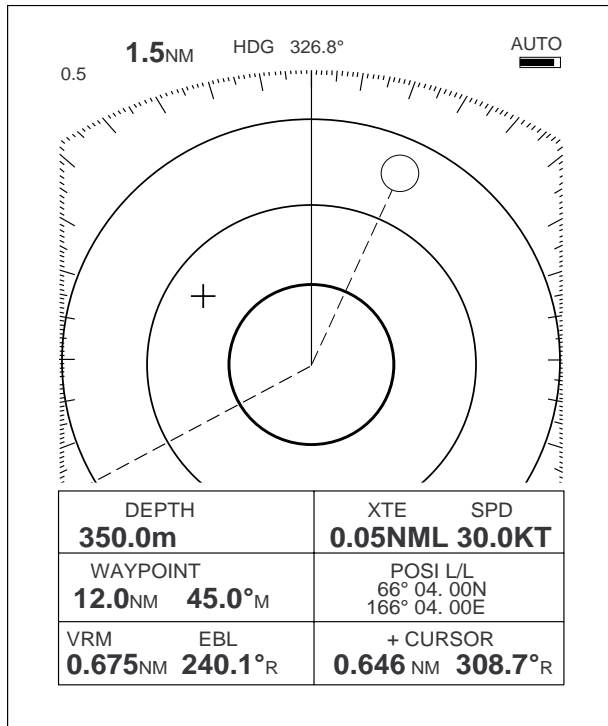

Figure 2-18 Sample nav data display

Setting up the nav data display

- 1) Press the [MENU] key.
- 2) Select Nav Data and press the [ENT] key.

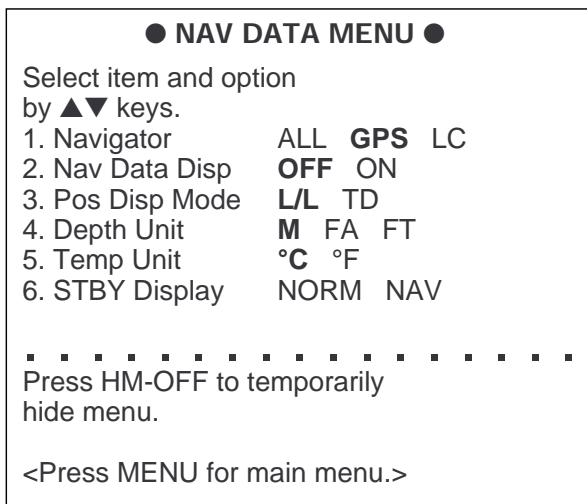

Figure 2-19 Nav data menu

- 3) Select Navigator; GPS, Loran C or ALL (Select all if several navigators are connected to the radar. In this case, position data is selected in order of GPS, Loran C and other.)

- 4) Select Nav Data Disp to OFF or ON.
- 5) Select Pos Disp Mode to L/L (latitude and longitude or TD (Loran C).
- 6) Select unit of depth measurement to meters, fathoms, or feet.
- 7) Select unit of measurement for water temperature to Centigrade or Fahrenheit.
- 8) Select whether to display nav data or "ST-BY". "NORM" for stand-by; NAV for navigation data.
- 9) Press the [ENT] key followed by the [MENU] key.

2.23 Echo Stretch (magnifying long range echoes)

Normally, the reflected echoes from long range targets appear on the display as weaker and smaller blips even though they are compensated by the radar's internal circuitry. To stretch long range echoes, in the range direction, turn on the echo stretch function.

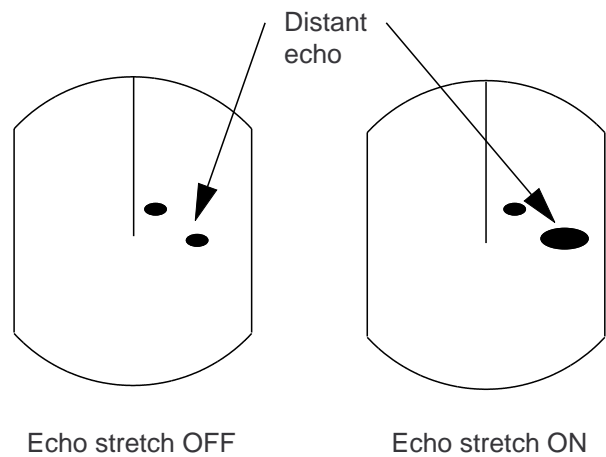

Figure 2-20 Echo stretch

Turning echo stretch on or off

- 1) Press the [MENU] key.
- 2) Select P/L & Int/Noise Rej & ES and press the [ENT] key.
- 3) Select Echo Stretch.

- 4) ON or OFF.
- 5) Press the [ENT] key followed by the [MENU] key. ES appears at the top right side on the display when the echo stretch feature is on.

Note 1: This function magnifies not only targets but also sea clutter and radar interference. For this reason be sure the controls for adjustment of sea clutter and radar interference are properly adjusted before activating the echo stretch.

Note 2: Echo stretch is inoperative on ranges from 0.25 to 0.75 nautical miles. ES appears in reverse video when you try to turn on the echo stretch in those ranges.

Note 3: When the echo stretch function is selected, Interference Rejection level #3, along with the Noise Rejection circuits, are automatically enabled. These can be turned off via menu selection if desired.

2.24 Selecting Unit of Measurement for Range

The unit of measurement for the VRM and cursor can be nautical miles, kilometers, or statute miles. You may select unit desired as follows.

- 1) Press the [MENU] key.
- 2) Select Mode & Function and press the [ENT] key.
- 3) Select VRM Unit to nm, km, or sm.
- 4) Press [ENT] followed by [MENU] key.

2.25 Selecting Bearing Reference

Bearing can be displayed relative to north (relative bearing) or relative to true north (true bearing) as follows. (True bearing requires heading sensor input.)

- 1) Press the [MENU] key.
- 2) Select Mode & Function and press the [ENT] key.

- 3) Select EBL Ref.
- 4) Select Rel(ative) or True.
- 5) Press the [ENT] key followed by the [MENU] key.

2.26 Watchman

How watchman works

The watchman function periodically transmits the radar for about one minute to check for targets in a guard zone. If it finds change in the zone from the previous transmission it sounds the aural alarm, cancels the watchman function, and transmits the radar continuously. This feature is useful when you do not need the radar's function continuously but want to be alerted to radar targets in a specific area.

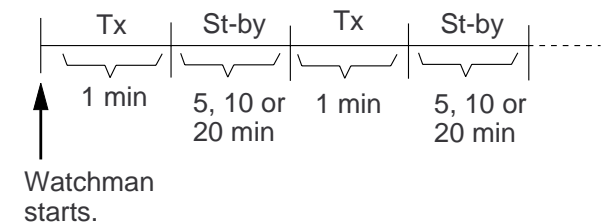

Figure 2-21 How watchman works

Turning on watchman

- 1) Create a guard zone (usually 360 degrees) with the guard alarm function.
- 2) Press the [MENU] key.
- 3) Select Mode & Function and press the [ENT] key.
- 4) Select Watchman.
- 5) Select watchman rest interval (amount of time until next rotation of antenna); 5 minutes, 10 minutes or 20 minutes.
- 6) Press the [ENT] key followed by the [MENU] key. Then, WATCHMAN appears, and the radar transmits for one minute and then goes into stand-by.

2.30 Outputting Cursor Position to Navigator

Cursor position (NMEA0183 data sentence TLL) can be output to the navigator connected to this radar by pressing and holding down the [HM OFF] key.

2.31 Displaying Cursor Position, Range and Bearing to Cursor

The cursor data indication at the bottom of the display can show cursor position in latitude and longitude or the range and bearing from own ship to the cursor. You can select the indication desired by pressing the [HM OFF] key.

2.32 Visual Alarm Indications

This radar display various visual alarms to alert you to error.

Table 2-1 Visual alarm indications

Error	Visual alarm
No heading pulse	HD SIG MISSING
No bearing pulse	BP SIG MISSING
Heading signal turned off	***.* (appears as heading)

The heading signal visual alarm may be cleared by pressing the [DISP MODE] key.

3. INTERPRETING THE DISPLAY

As an aid to navigation, radar can be a very valuable tool. No other electronic navigation aid can give you the ability to spot vessels coming at you in the fog, or tell you the location of the inlet to the harbor in the pitch black of night.

To help you understand what your radar can (and cannot) do for you this chapter covers

- the characteristics of the radar wave
- target properties and radar wave reflection
- range and bearing resolution, and
- false echoes.

3.1 The Radar Wave and Radar Horizon

How the radar wave travels

The radar wave tends to travel in straight lines at the speed of light. However, it is subject to bending or refraction in the atmosphere, the amount depending on region and density.

Super-refraction

Super-refraction is a condition in which there is an upper layer of warm dry air over a surface layer of cold, moist air. Radar waves bend downward and thus increase the ranges at which targets may be detected.

Sub-refraction

Sub-refraction is the reverse condition of super-refraction; a layer of cold air is above a layer of warm air. Radar waves bend upward and thus decrease the ranges at which targets may be detected.

Radar horizon

Radar is essentially a “line-of-sight” phenomenon. That means you have just about the same range to horizon with a radar as you do with your own eyes. However under normal atmospheric conditions, the radar horizon is 6% greater than the optical horizon. Therefore, if the target does not rise above the horizon the radar beam cannot be reflected from the target.

The distance to the horizon from the scanner, under normal conditions, is calculated by the following formula.

$$R_{max} = 2.2 \times \sqrt{h_1} + \sqrt{h_2}$$

Where R_{max} : Radar horizon (mile), h_1 : Antenna height (meters), h_2 : Target height (meters)

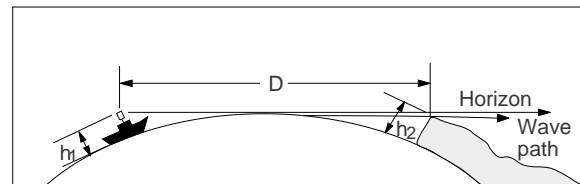

Figure 3-1 Radar horizon

3.2 Target Properties and Radar Wave Reflection

Generally, larger targets can be seen on the radar display at greater ranges, provided line-of-sight exists between the scanner and target. However, a large target with poor reflecting properties may not be detected as easily as a smaller target with better reflecting properties. For example, you might expect a lighthouse to be a good radar target because of its size. In actuality the return echo is weak since the conical shape diffuses most of the radiated energy.

A ship whose hull is made of conducting materials, such as steel, will return a relatively strong echo.

On the other hand, hulls made from wood or fiberglass return much weaker echoes.

Vertical surfaces, such as a cliff, are good targets provided they face the radar. Conversely, horizontal and smooth surfaces such as mudbanks, sandy beaches, and gently sloping hills make poor targets because they disperse rather than reflect most of the energy that strikes them.

The strongest radar echoes known come from built-up areas, docks, etc., because these targets are less subject to changes in aspect. These types of targets have three flat, smooth surfaces mutually at right angles. Some radar buoys are arranged this way so as to deliberately increase their detection range.

3.3 Range Resolution

Range resolution is a measure of the capability of a radar to display as separate pips the echoes received from two targets which are on the same bearing and are close together.

The main factor which affects range resolution is pulselength. Two targets on the same bearing, close together, cannot be seen as two distinct echoes on the display unless they are separated by a distance greater than one-half the pulselength.

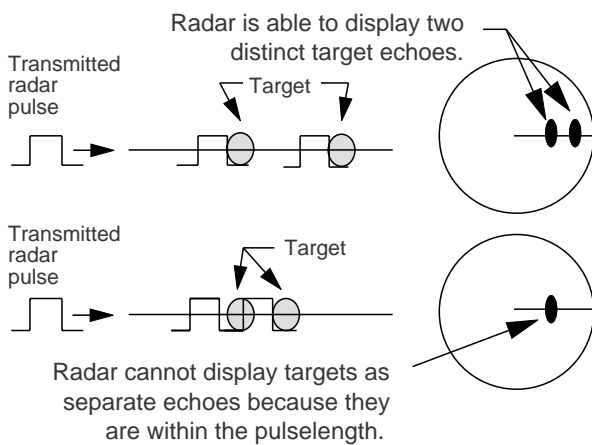

Figure 3-2 Range resolution

3.4 Bearing Resolution

Bearing resolution is a measure of the capability of a radar to display as separate targets the echoes received from two targets which are at the same range and are close together.

The principal factor which affects bearing resolution is horizontal beamwidth. Two targets at the same range must be separated by more than one beamwidth to appear as separate pips.

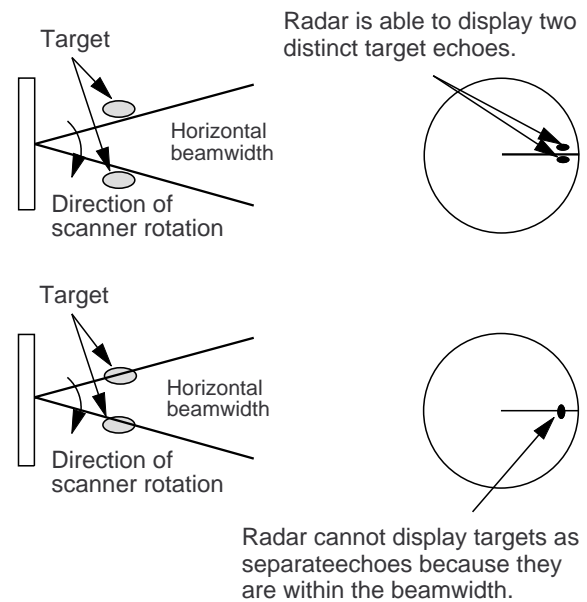

Figure 3-3 Bearing resolution

3.5 False Echoes

Occasionally false echoes appear on the screen at positions where there is no target. In some cases the effects can be reduced or eliminated. The operator should familiarize himself or herself with the appearance and effects of these false echoes, so as not to confuse them with echoes from legitimate contacts.

Multiple echoes

Multiple echoes occur when a short range, strong echo is received from a ship, bridge, or breakwater. A second, a third or more ech-

oes may be observed on the display at double, triple or other multiples of the actual range of the target as shown in Figure 3-4. Multiple reflection echoes can be reduced and often removed by decreasing the sensitivity or properly adjusting the STC.

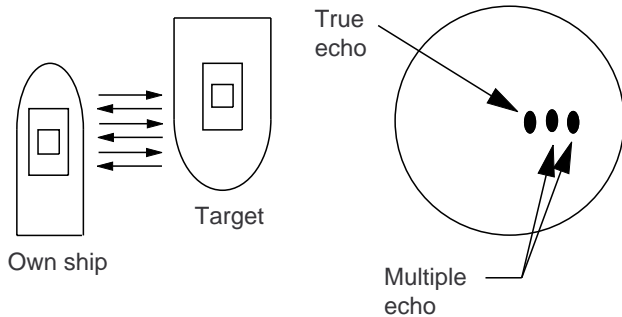

Figure 3-4 Multiple echoes

Side-lobe echoes

Every time the scanner rotates, some radiation escapes on each side of the beam—called “side-lobes.” If a target exists where it can be detected by the side-lobes as well as the main-lobe, the side-lobe echoes may be represented on both sides of the true echo at the same range, as shown in Figure 3-5. Side-lobes show usually only at short ranges and from strong targets. They can be reduced through careful reduction of the sensitivity or proper adjustment of the STC.

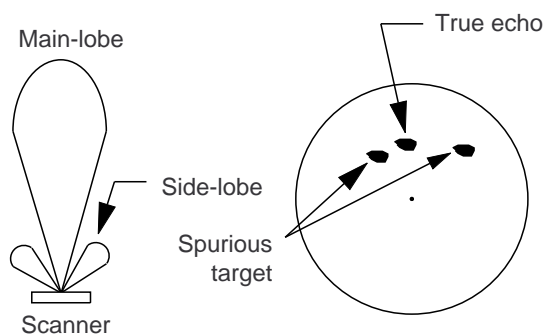

Figure 3-5 Side-lobe echoes

Indirect echoes

Indirect echoes may be returned from either a passing ship or returned from a reflecting surface on your own ship, for example, a stack. In both cases, the echo will return from a legitimate contact to the antenna by the same indirect path. The echo will appear on the same bearing of the reflected surface, but at the same range as the direct echo. Figure 3-6 illustrates the effect of an indirect echo. Indirect echoes may be recognized as follows:

- they usually occur in a shadow sector
- they appear on the bearing of the obstruction but at the range of the legitimate contact
- when plotted, their movements are usually abnormal, and
- their shapes may indicate they are not direct echoes.

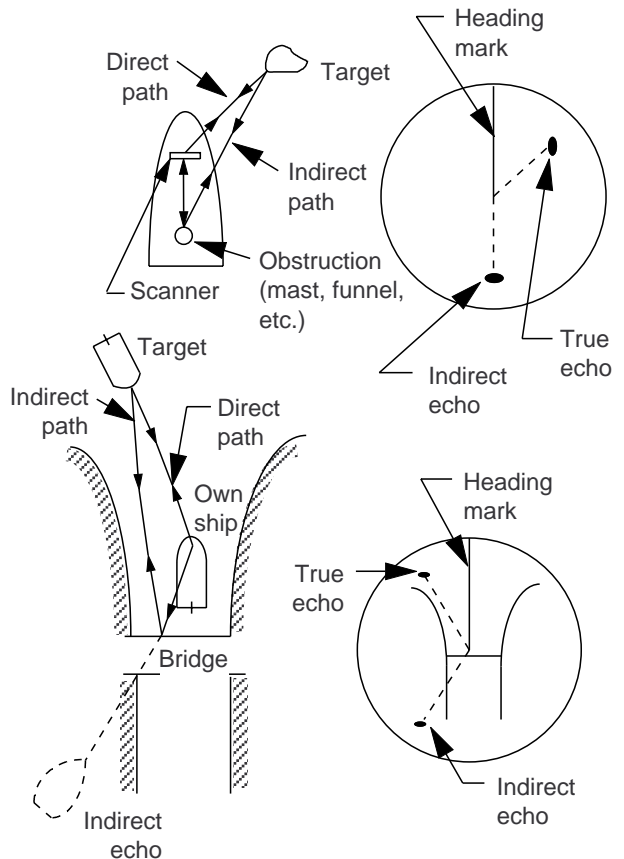

Figure 3-6 Indirect echoes

Blind and shadow sectors

Funnels, stacks, masts, or derricks in the path of antenna may reduce the intensity of the radar beam. If the angle subtended at the scanner is more than a few degrees a blind sector may be produced. Within the blind sector small targets at close range may not be detected while larger targets at much greater ranges may be detected. See Figure 3-7.

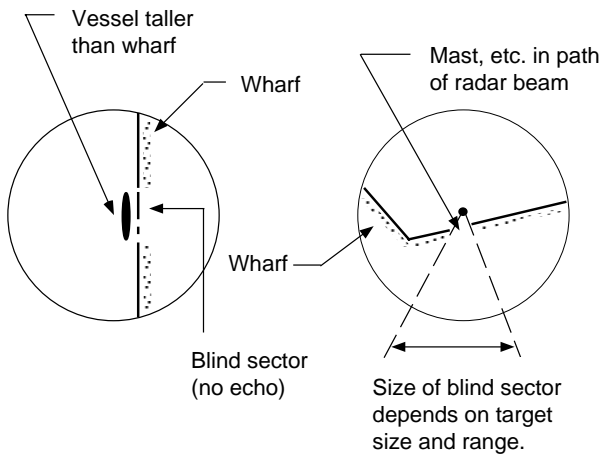

Figure 3-7 Blind and shadow sectors

3.6 Nautical Chart and Radar Picture

Under normal conditions, a picture which is similar to a nautical chart can be obtained on the radar display. However, a radar cannot:

- show targets which are below the horizon.
- show a target which is hidden by a larger one.
- see around corners (for example, sea-wall).
- distinguish between two targets which are very close together, either in range or bearing. For example, a vessel towing another will probably appear as one vessel, as both will be covered by the beam at the same time.

The nautical chart and radar picture shown in Figure 3-8 are from the Kada Inland Sea in southwestern Japan.

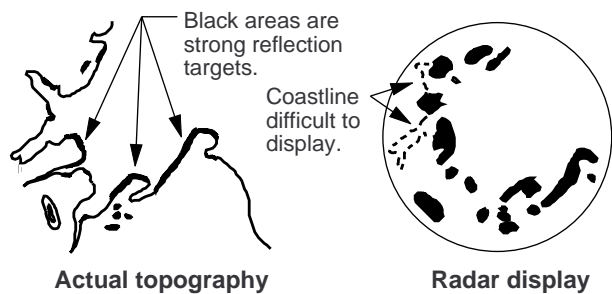



Figure 3-8 Nautical chart and associated radar picture

4. MAINTENANCE & TROUBLESHOOTING

This chapter tells you how to keep your radar in good working order. Before reviewing this chapter please read the safety information which follows.

4.1 Safety Information

ELECTRICAL SHOCK HAZARD

 WARNING

Hazardous voltages. Can shock, burn or cause death.
Only qualified personnel should work inside the units of the radar.

This equipment uses high voltage electricity which can shock, burn or cause death. While the equipment has been designed with consideration for the operator's safety, precautions must always be exercised when reaching inside

the equipment for the purpose of maintenance or service. For this reason, only qualified personnel totally familiar with electrical circuits and service manual should work inside the display unit or scanner unit.



RF RADIATION HAZARD

The radar scanner emits high frequency radio radiation which can be harmful, particularly to your eyes. Never look directly into the scanner from a distance of less than two feet when the radar is in operation as you could injure the cornea of your eyes. Always make sure the radar is set to stand-by or is turned off before starting work on the scanner unit.



Turn off the power before performing any maintenance or troubleshooting procedure.

4.2 Preventative Maintenance

Regular maintenance is important for good performance. Always keep the equipment as free as possible from dirt, dust, and water splashes. Make sure all screws securing the components are properly tightened.

A maintenance program should be established and should at least include the items listed in Table 4-1.

4.3 Replacing the Fuse

The 5A fuse in the power cable protects the equipment against reverse polarity of ship's mains, overcurrent, and equipment fault. If the fuse blows, find the cause before replacing it. Never use a fuse rated for more than 5A—serious damage to equipment may result and void the warranty.

Table 4-1 Recommended maintenance program

Period	Item	Check point	Remarks
3 to 6 months	Fixing bolts for antenna unit	Check for tightness and corrosion.	Replace corroded bolts. Coat bolts with anti-corrosive sealant.
	Radome cleanliness	Foreign material on the radome face will cause a considerable drop in performance. Clean the radome with a freshwater.	The only recommended cleaning agent is alcohol. Do not use other cleaning agents; they can remove paint and markings.
	Radome cover	Check for wear. Permanent damage to the antenna's internal circuitry will result if water leaks into the radome.	If a crack is found it should be temporarily repaired by using a small amount of sealing compound or adhesive. You should then contact your dealer for service.
	LCD	The LCD will, in time, accumulate a coating of dust which tends to dim the picture. Wipe LCD lightly with a soft cloth.	Do not use chemical cleaners to clean any part of the display unit; they can remove paint and markings.
6 months to 1 year	Display unit connectors	Check for tight connection and corrosion.	If corroded, contact your dealer for replacement.

4.4 Troubleshooting

Table 4-2 contains simple troubleshooting procedures which you can follow to try to restore normal operation. If you cannot restore normal operation, do not attempt to check inside any unit of the radar system. Any repair work is best left to a qualified technician.

Table 4-2 Troubleshooting table

If...	But...	Then...
you pressed the [POWER] key to turn on the radar	the control panel does not light	<ul style="list-style-type: none"> • try adjusting the control panel backlighting on the Brilliance/Backlighting menu. • battery may have discharged. • check fuse in power cable.
	nothing appears on the display or display contrast is poor	<ul style="list-style-type: none"> • try adjusting the tone. (Extreme ambient temperature may affect display tone.)
	characters are distorted	<ul style="list-style-type: none"> • request service.
the radar has warmed up and you pressed the [ST-BYTX] key to transmit	the antenna does not rotate	<ul style="list-style-type: none"> • the problem may be in antenna unit. Request service.
	characters and indications are abnormal	<ul style="list-style-type: none"> • have a qualified technician check the set.
you have adjusted the gain with FTC and STC off	neither noise nor targets appear (indications and markers do)	<ul style="list-style-type: none"> • check signal cable for damage.
	neither indications nor markers appear (noise and targets do)	<ul style="list-style-type: none"> • check signal cable for damage.
	the sweep (radial line sweeping around the display) is not synchronized with antenna rotation	<ul style="list-style-type: none"> • the problem may be in the antenna unit. Request service.
	there is no change in sensitivity.	<ul style="list-style-type: none"> • request service.
a key is pressed	nothing happens	<ul style="list-style-type: none"> • key may be faulty. Request service.

4.5 Self Test

The self test facility checks the keyboard, ROM and RAM for proper operation. You may run the test as follows.

- 1) Press the [MENU] key.
- 2) Select Self Check. The following display appears.

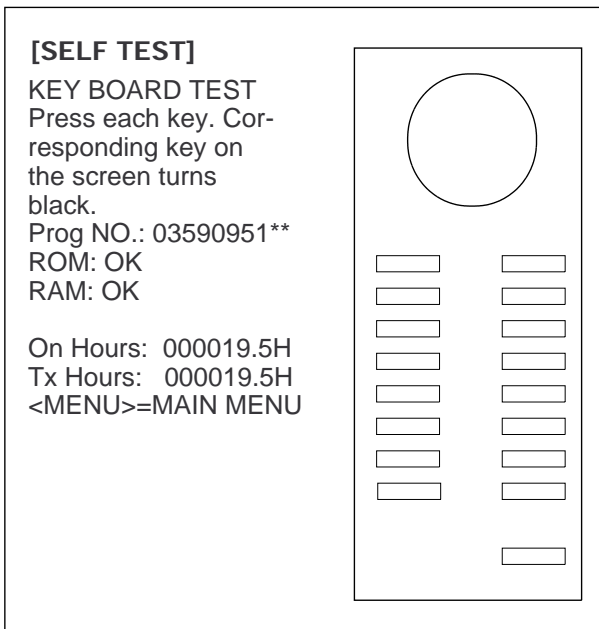

Figure 4-1 Self test screen

- 3) To check the keyboard, press a key. Its corresponding location on the display lights in black if the key is operating properly.
- 4) To escape the test, press the [MENU] key.

The ROM and RAM are automatically checked. If NG (No Good) appears to the right of ROM or RAM indication, contact your dealer for advice.

5. INSTALLATION

This chapter provides the procedures necessary for installation. Installation mainly consists of the following:

- siting and mounting the display unit and antenna unit
- connection of the signal cable and the power cable
- establishing the ground
- checking the installation, and
- adjustments.

5.1 Antenna Unit Installation

Siting, handling considerations

- The antenna unit is generally installed either on top of the wheelhouse or on the radar mast on a suitable platform. Locate the antenna unit where there is a good all-round view rigging intercepting the scanning beam. Any obstruction will cause shadow and blind sectors. A mast for instance, with a diameter considerably less than the width of the radiator, will cause only a small blind sector, but a horizontal spreader or crosstrees in the same horizontal plane as the antenna unit would be a much more serious obstruction; you would need to place the antenna unit well above or below it.
- It is rarely possible to place the antenna unit where a completely clear view in all direction is available. Thus, you should determine the angular width and relative bearing of any shadow sectors for their influence on the radar at the first opportunity after fitting. (The method of determining blind and shadow sectors appears later in this chapter.)
- If you have a radio direction finder on your boat, local its antenna clear of the antenna unit, to prevent interference to the direction finder. A separation of more than two meters is recommended.
- To lessen the chance of picking up electrical interference, avoid where possible routing the signal cable near other onboard electrical equipment. Also avoid running the cable in parallel with power cables.

- The compass safe distance should be observed to prevent deviation of the magnetic compass.

Standard compass	Steering compass
0.9 m	0.7 m

- Do not paint the radome to ensure proper emission of the radar waves.
- When this radar is to be installed on larger vessels, consider the following points:

- (1) The signal cable run between the antenna and the display comes in lengths of 10 m, 15 m, 20 m and 30 m. Whatever length is used it must be unbroken; namely, no splicing allowed.
- (2) Deposits and fumes from a funnel or other exhaust vent can adversely affect the aerial performance and hot gases may distort the radiator portion. The antenna unit must not be mounted where the temperature is more than 70°C.

Mounting

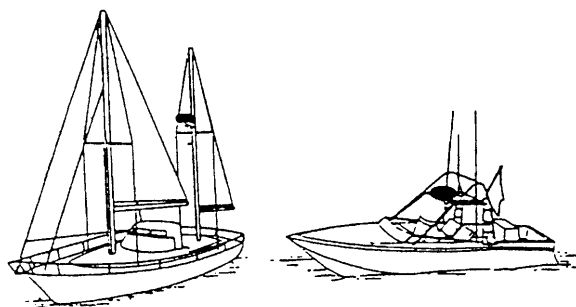

Figure 5-1 Typical antenna unit location

Unpacking the antenna unit

1. Open the antenna unit packing box carefully.
2. Unbolt the four bolts at the base of the radome to remove the radome cover.

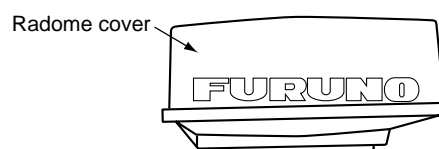

Figure 5-2 Antenna unit

Mounting platform

Holes for antenna unit:

The mounting surface must be parallel with the waterline and provided with five holes whose dimensions are shown in the outline drawing attached at the end of this manual.

The unit is adjusted so a target echo returned from the bow direction will be shown on the zero degree (heading line) position on the screen. When drilling holes, be sure they are parallel with the fore and aft line.

3. Prepare a platform of 5 to 10 millimeters in thickness for the antenna unit. (A mounting bracket for mounting the antenna unit on a sailboat mast is optionally available. See Figure 5-1.) Find the cable entry on the radome base. Next, position the radome base so the cable entry faces the stern direction. This alignment must be as accurate as possible. Fasten the radome base to the mounting platform with four each of M10 x 25 hex bolts, flat washers and spring washers.

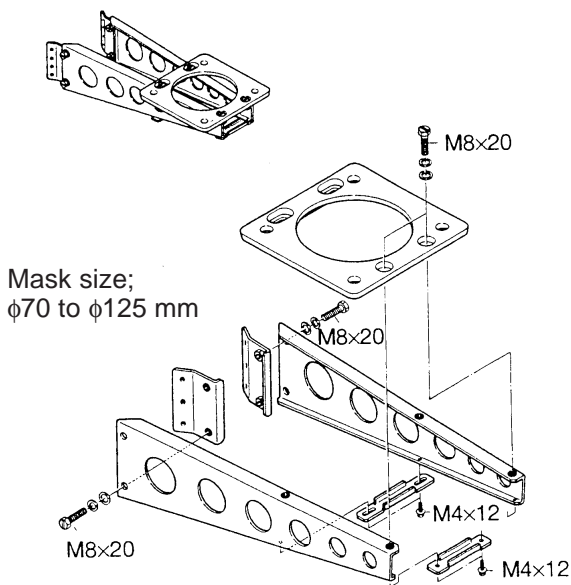

Type: OP03-92
Code no.: 008-445-070

Figure 5-3 Assembling the sailboat mast mounting bracket (option)

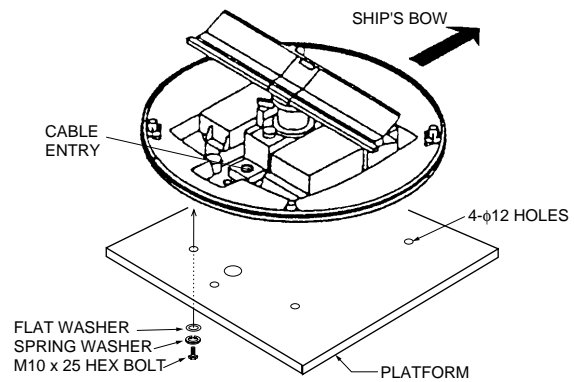

Figure 5-4 Antenna Unit, cover removed

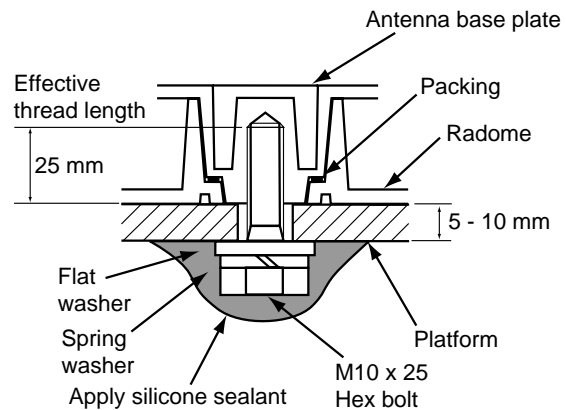
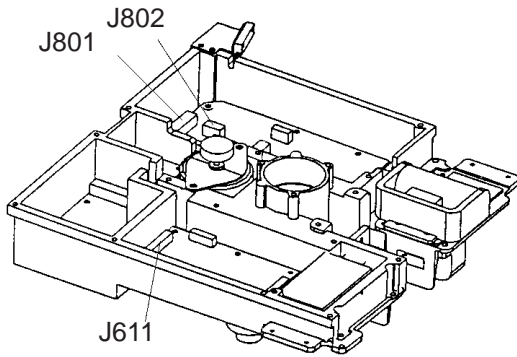

Figure 5-5 How to fasten the radome base to the mounting platform

Wiring and final preparation

4. Drill a hole of at least 20 millimeters diameter through the deck or bulkhead to run the signal cable between the antenna unit and the display unit. (To prevent electrical interference avoid running the signal cable near other electrical equipment and in parallel with power cables.) Pass the cable through the hole. Then, seal the hole with sealing compound for waterproofing.
5. Remove the shield cover in the radome.
6. Remove the cable clamping plate by unfastening four screws and removing a gasket.
7. Pass the cable through the hole at the bottom of the radome base.
8. Secure the cable with the cable clamping plate and gasket. Ground the shield and vinyl wire by one of the screws of the cable clamping plate and one of the screws of the IF amplifier chassis, respectively.
9. Connect the wire to the RF unit.

- (1) 13-pin connector to J611 on IF-9215
- (2) 9-pin connector to J801 on MD-9208
- (3) 4-pin connector to J802 on MD-9208



Location of J611/J801/J802

10. Fix the shield cover. Do not pinch the cable.
11. Attach the radome cover, aligning triangle mark on radome cover with that on radome base.

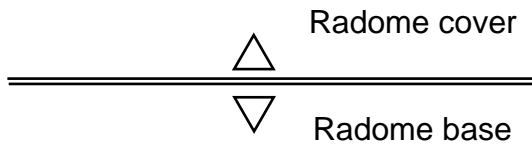

Figure 5-6 How to position the radome cover

12. Loosely fasten the radome fixing bolts. You will tighten them after confirming magnetron heater voltage.

5.2 Display Unit Installation

Mounting considerations

When selecting a mounting location for the display unit keep in mind the following points.

- The display unit is designed and constructed to be splashproof, thus it can be installed outdoors. You can even hose it down after a day's outing. If it is to be installed outdoors, we recommend installing it in an enclosed cabinet, for maximum protection against the marine environment.
- The temperature and humidity of the mounting location should be stable and moderate. No LCD can provide adequate contrast if the ambient temperature is too extreme.
- The display unit consumes only a moderate amount of power, so there is no need for forced air ventilation. However, you should provide adequate space behind and around the unit to permit circulation of air and to provide convenient access to the rear connectors.
- Even though the picture is quite legible even in bright sunlight, keep the display unit out of direct sunlight or at least shaded because of heat that can build up inside the cabinet.
- Locate the display unit in a position where you can view and operate it conveniently but where there is no danger of salt or fresh water spray or immersion.
- The orientation of the display unit should be so the radar screen is viewed while the operator is facing in the direction of the bow. This makes determination of your position much easier.
- Make sure you allow enough clearance both to get to the connectors behind the unit and to allow you to get your hands in on both sides to loosen or tighten the mounting knobs. Make sure you leave at least a foot or so of "service loop" of cables behind the unit so it can be pulled forward for servicing or easy removal of the connectors.
- A magnetic compass will be affected if placed too close to the display unit. Observe the minimum compass safe distances to prevent deviation of a magnetic compass: standard compass, 0.7 meters, and steering compass, 0.5 meters.

Mounting procedure

The display unit is designed to be mounted on a tabletop.

- 1) Using the hanger as a template, mark screw locations in the mounting location.
- 2) Fix the hanger to the mounting location with four M6 tapping screws (supplied).
- 3) Fit the knob bolts to the display unit.
- 4) Install the display unit in the hanger.
- 5) Tighten the knob bolts securely.

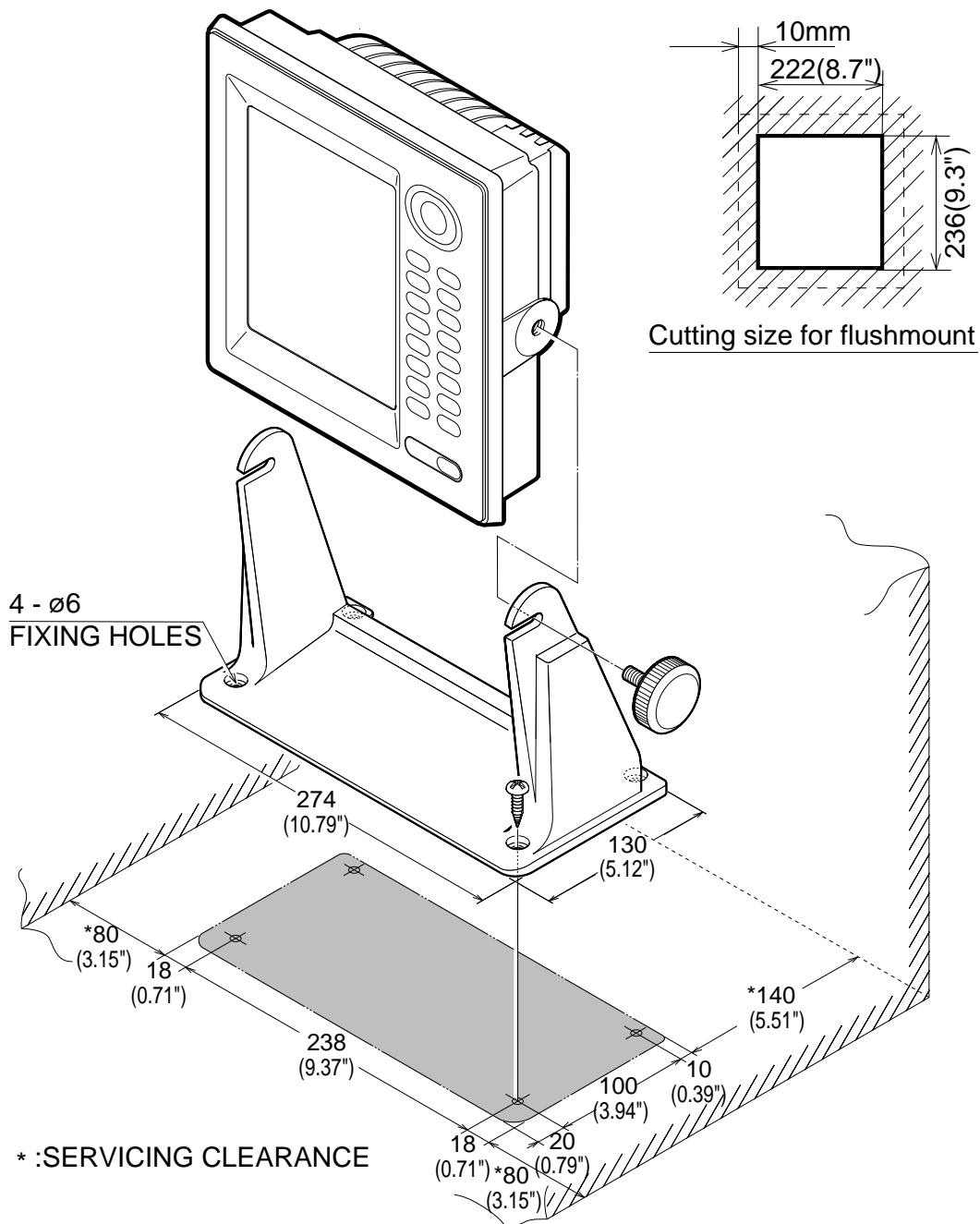

Figure 5-13 How to mount the display unit

Connections

Connect the signal and power cables, the ground wire and optional equipment as shown in Figure 5-14.

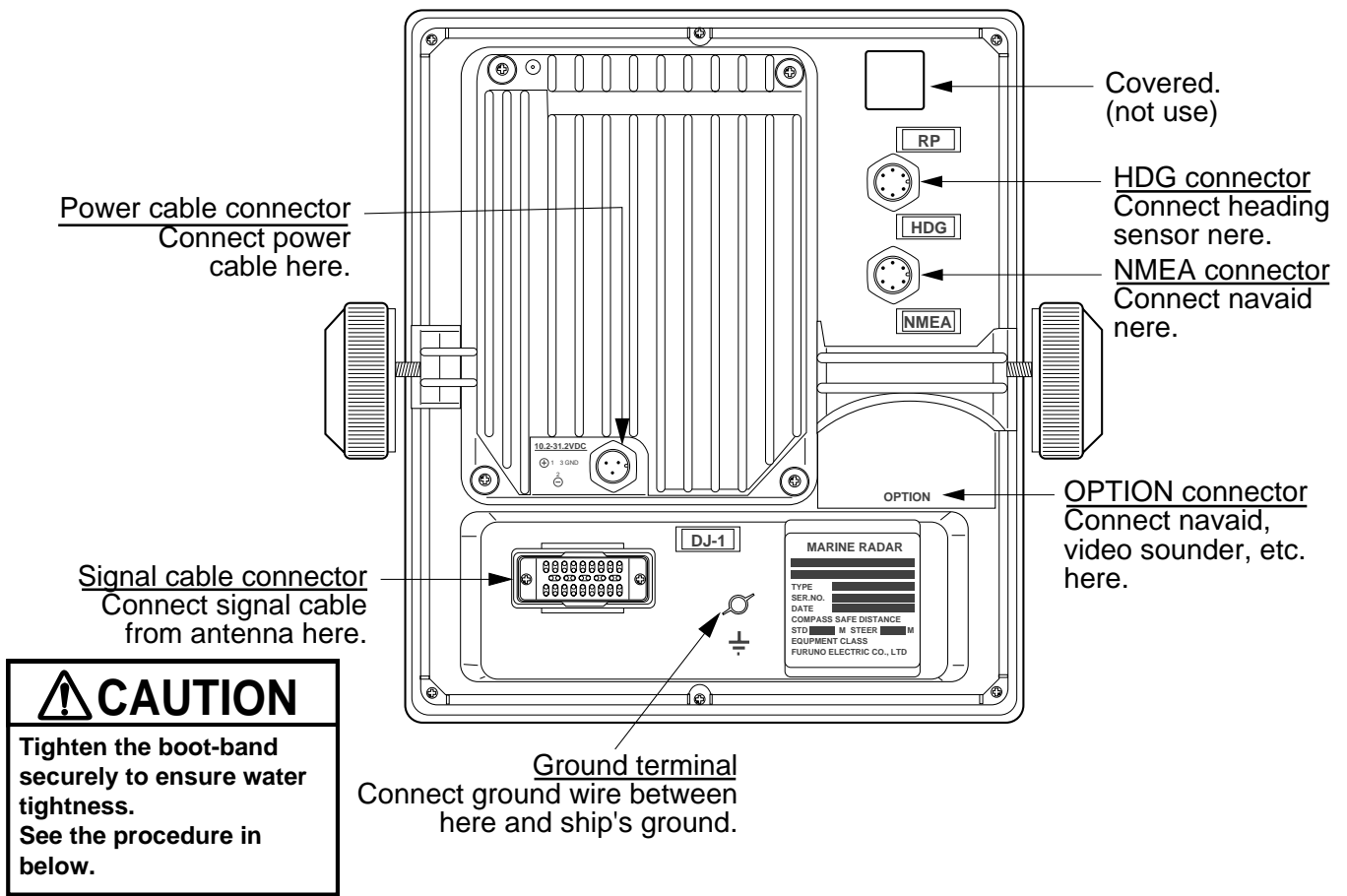
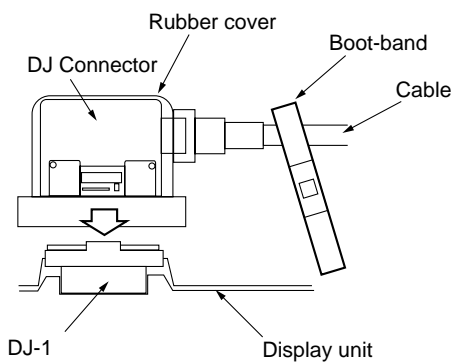

Figure 5-14 Display unit, rear view

Signal cable connection

1. Connect the signal cable to DJ-1 on the rear panel of the display unit.



2. Cover the connector with the rubber cover. The projection on the connector base is inserted into the groove on the rubber cover.

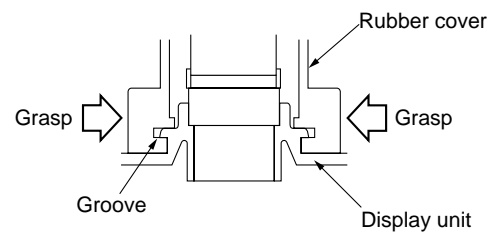

3. Put the boot-band as shown below, and tighten it.

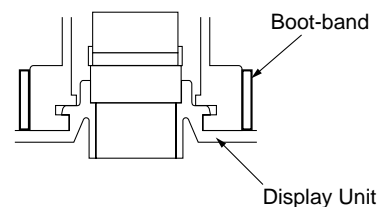

Navigation aid, video sounder connection

If your navigation aid can output data in NMEA 0183 data format, your vessel's position in latitude and longitude, the range and bearing to waypoint, speed, and course may be input to this radar, and be seen in the bottom text area.

Further, if your video sounder can output depth in NMEA 0183 data format, depth can be displayed on the navigation data displayed in graph form during stand-by.

You will need an NMEA cable:

For navaid;

Type	Code no.	Remarks
MJ-A6SPF0012-050	000-134-424	6P-6P(5m)
MJ-A6SPF0012-100	000-133-817	6P-6P(10m)

For E/S;

Type	Code no.	Remarks
MJ-A6SPF0011-050	000-132-224	6P-4P(5m)
MJ-A6SPF0011-100	000-132-336	6P-4P(10m)

Two NMEA connectors are provided at the rear of the display unit: the NMEA connector and the OPTION connector.

Heading Sensor Connection

Heading signal can be connected to the "HDG" connector. 10 m cable assembly is optionally available.

Type	Code no.	Remarks
MJ-A6SPF0007-100	000-125-237	C-2000
MJ-A6SPF0009-100	000-125-236	AD-100

The OPTION connector

To connect external equipment to the OPTION connector;

- 1) Remove the plastic cover on the connector.
- 2) Connect equipment to J61 on the SPU Board as shown in Figure 5-15.

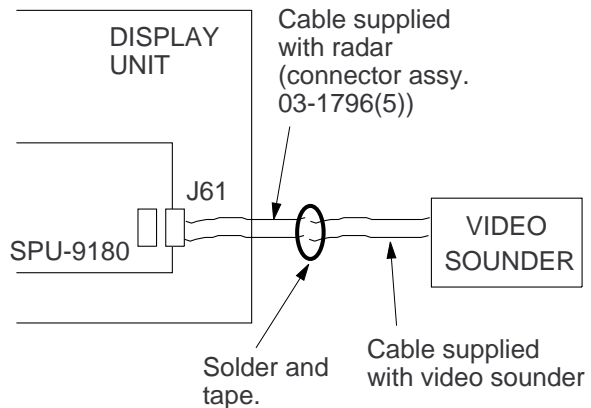
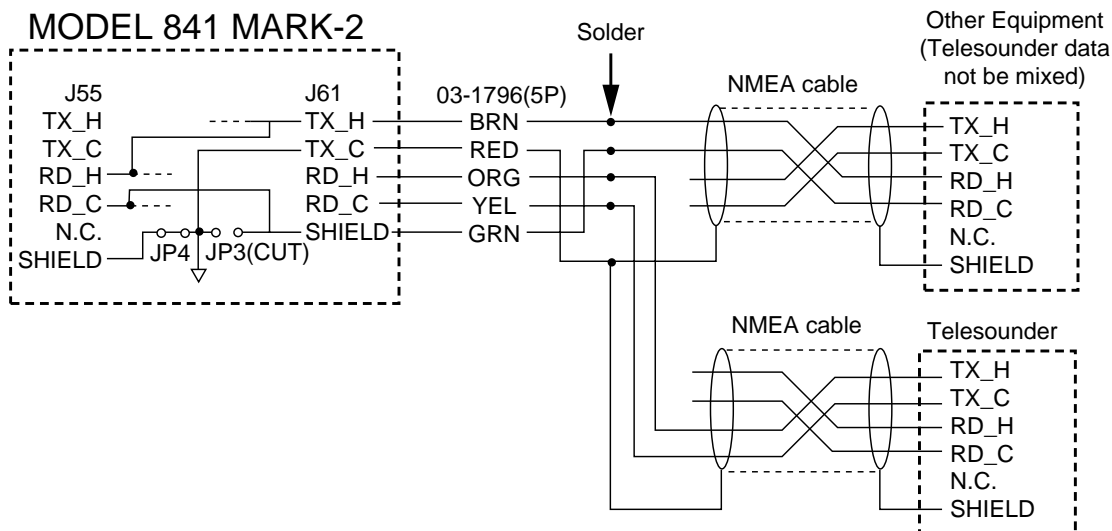

Figure 5-15 How to connect external equipment to the OPTION connector

- 3) Cover signal cable at junction with display unit with silicone sealant.

Distribution NAV data to the other equipment

This radar can output NAV data received from a navaid to an echosounder or video plotter by making the modifications as shown in below.



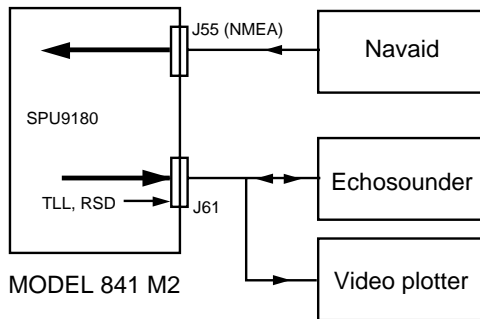

The position data from navaid can be used for the echosounder if a video plotter is not connected.

Procedure

1. Unfasten the nuts fixing the waterproof connector to remove the covers of the power and display unit.
2. Remove all connectors from SPU Board (SPU-9180).
3. Unfasten three screws to remove the board.
4. Remove JP3, R91 and R92 on the parts side of SPU Board.

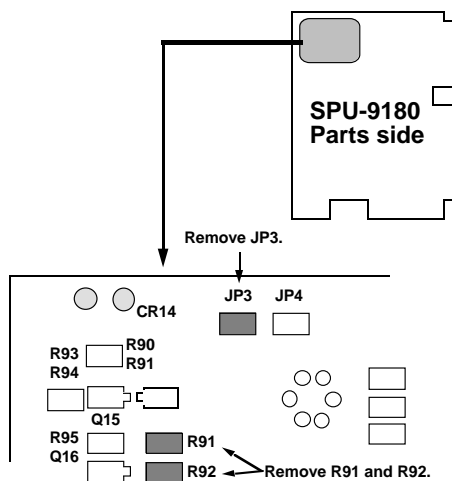

5. Add jumper wire between J55 pin #3(RXD-H) and J61 pin #1(TXD-H).
6. Add a jumper wire between J55 pin #4(RXD-C) and J61 pin #5(SHIELD).

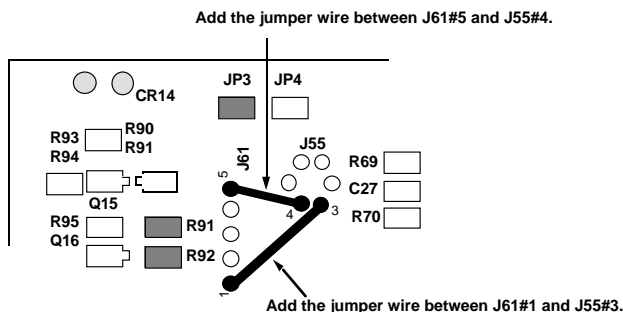

7. Connect the NMEA cable to the connector assy (03-1796/5P, supplied with radar) as shown the figure on next page.
8. Connect the 5P connector to J51 on SPU Board.
9. Replace the covers removed in step 1.
10. Connect navaid and other equipment to radar.
11. Turn on the radar and confirm that NAV data in properly received at the radar and external equipment.

5.3 Installation Check List

After completing the installation it is a good idea to check for proper installation. Follow the checklist below and tick boxes to show proper completion.

- Is the vent tube on the antenna housing on the stern side?
- Are the four bolts for fixing the radome tightened?
- Is the signal cable waterproofed at the radome base?
- Is the signal cable secured against a mast or bulkhead?
- Is the cable gland or cable entry on the deck fully waterproofed?
- Are the connections to the battery of correct polarity?
- Are all the antenna and display units grounded?
- Are all connectors at the rear of the display unit fastened securely?

CAUTION

If it is necessary to open the display unit, be sure the rear cover is fitted to the front chassis properly when closing the rear cover. When reassembling, first turn off the unit and then press the center of the rear cover to plug in the multipin connector on the rear cover.

5.4 Initial Adjustment of Picture

Follow the procedure below to obtain proper radar picture.

- 1) Press the [POWER] key on the display unit. The display should light. Wait until the message "ST-BY" appears on the screen. (About 1:30.)
- 2) Press [TX ST-BY] key to transmit. The radar will start transmitting, and you will probably see some targets around you, even though the radar is not yet properly adjusted.
- 3) Select a long range.
- 4) Press the [ECHO] key. The following display appears.

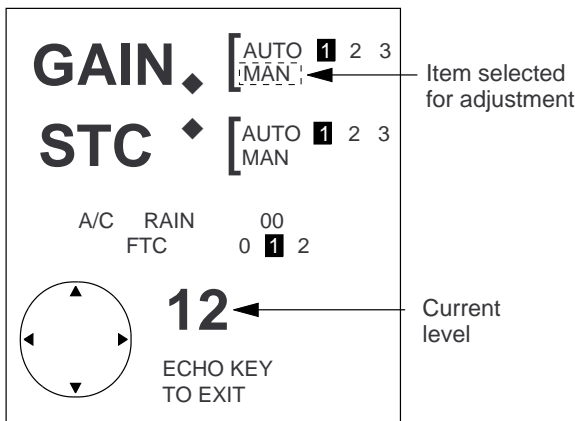

Figure 5-16 Display for adjustment of gain, STC, A/C RAIN and FTC

- 5) Press the cursor pad to select GAIN-AUTO, if it is not already selected.
- 6) Select minimum range. Press the [ECHO] key and press the cursor pad to select STC-AUTO, if it is not already selected.

5.5 Displaying the Installation Menus

Two sets of installation menus, Installation Setup 1 and Installation Setup 2 enable entry of initial settings and adjustment of the radar.

Procedure

- 1) Turn on the power while pressing and holding down the [HM OFF] key.
- 2) Press the [MENU] key.

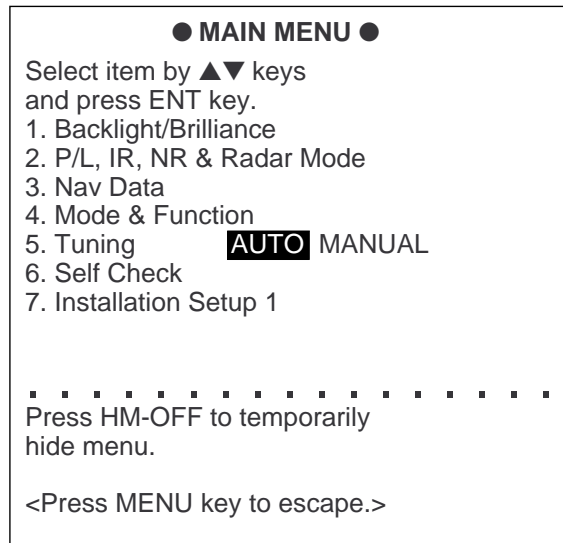

Figure 5-17 main menu

- 3) Press the cursor pad to select Installation Setup 1 and press the [ENT] key.

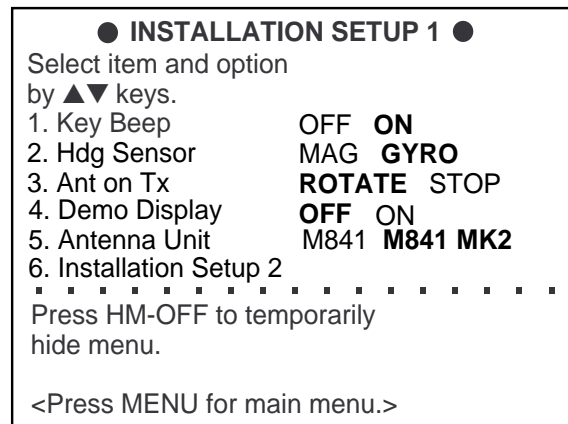

Figure 5-18 Installation setup menu 1

- 4) To display the Installation Setup 2 menu, press the cursor pad to select Installation Setup 2.

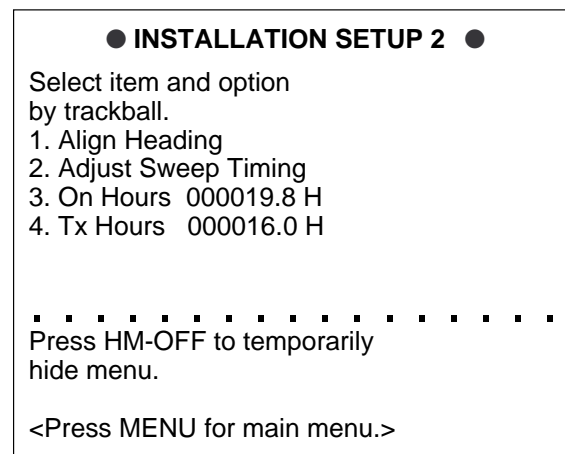

Figure 5-19 Installation setup 2 menu

5.6 Entering Initial Settings

- 1) At the Installation Setup 1 menu, press the cursor pad to select Key Beep. (Key Beep turns on or off the buzzer which sounds when a key is pressed.)
- 2) Press the cursor pad to select OFF or ON.
- 3) Select Hdg Sensor.
- 4) Select type of heading sensor connected to the radar; MAGnetic compass or GYROcompass.
- 5) Press the [ENT] key.
- 6) Select ANTENNA UNIT.
- 7) Select M841 when using M841 antenna unit.

Leave the menu open to complete the next several adjustments.

5.7 Relative Bearing Alignment

You have mounted the antenna unit facing straight ahead in the direction of the bow. Therefore, a small but conspicuous target dead ahead visually should appear on the heading mark (zero degrees).

In practice, you will probably observe some small error on the display because of the difficulty in achieving accurate initial positioning of the antenna unit. The following adjustment will compensate for this error, up to ± 30 degrees.

- 1) Identify a suitable target (for example, ship or buoy) at a range between 1/8 to 1/4 miles, preferably near the heading mark. To minimize error, keep echoes in the outer half of the picture by changing the range.
- 2) Display the Installation Setup 2 menu.

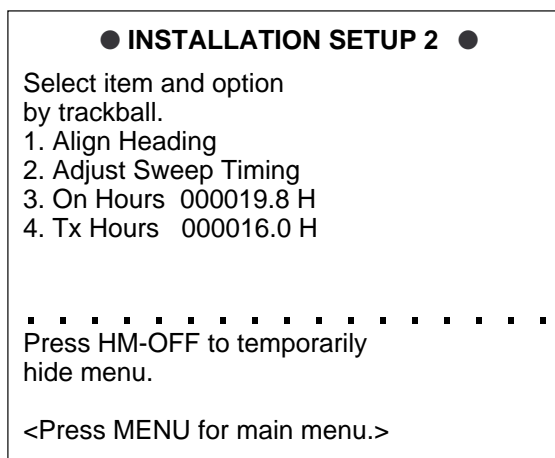

Figure 5-20 Installation setup 2 menu

- 3) Select Align Heading and press the [ENT] key.
- 4) Press the cursor pad to bisect the target selected at step 2 with the EBL.
- 5) Press the [ENT] key,
- 6) As a final test, move the boat towards a small buoy and confirm that the buoy shows up dead ahead on the radar when it is visually dead ahead.

5.8 Sweep Timing

This adjustment ensures proper radar performance, especially on short ranges. The radar measures the time required for a transmitted echo to travel to the target and return to the source. The received echo appears on the display based on this time. Thus, at the instant the transmitter is fired, the sweep should start from the center of the display (sometimes called sweep origin.)

A trigger pulse generated in the display unit goes to the antenna unit through the signal cable to trigger the transmitter (magnetron). The time taken by the signal to travel up to the antenna unit varies, depending largely on the length of signal cable. During this period the display unit should wait before starting the sweep. When the display unit is not adjusted correctly, the echoes from a straight local object (for example, a harbor wall or straight pier) will not appear with straight edges—namely, they will be seen as “pushed out” or “pulled in” near the picture center. The range of objects will also be incorrectly shown.

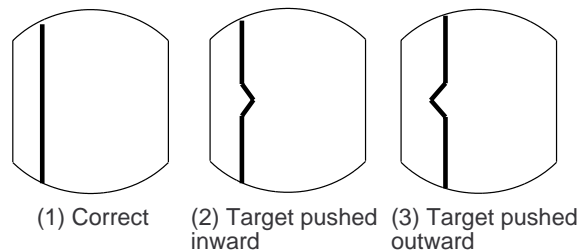

Figure 5-21 Examples of improper and correct sweep timings

- 1) Transmit the radar on the shortest range and adjust the sensitivity and STC.
- 2) Visually select a straight echo (harbor wall, straight pier).
- 3) Display the Installation Setup 2 menu and select Adjust Sweep Timing.
- 5) While looking at the target selected at step 2, press cursor pad at the 9 o'clock or 3 o'clock position to straighten the target.
- 6) Press the [ENT] key.

5.9 Closing the Installation Menus

Press the [MENU] key and turn off the power.

Table 5-1 Voltage ratings (reference for installer)

Item	MODEL 841 M2		Remarks
	TP802 #5	0.9-1.1V	
Magnetron current	TP802 #5	0.9-1.1V	Tx, long range
Magnetron heater voltage	TP802 #4	7.4-7.6V	Stand-by
HV	TP802 #1	290-330V	Tx, long range

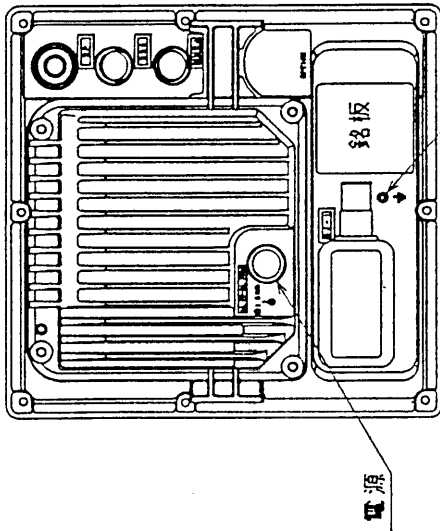

MIN 150
SERVICING
CLEARANCE

108

47

6

15

アース端子
GND TERMINAL

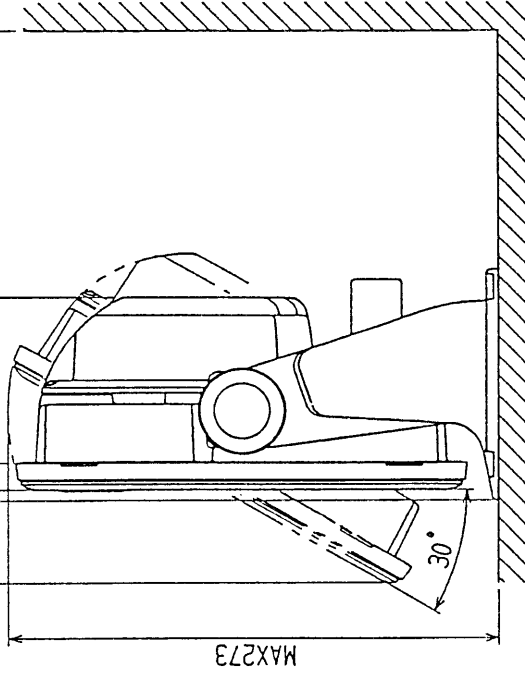

MAX273

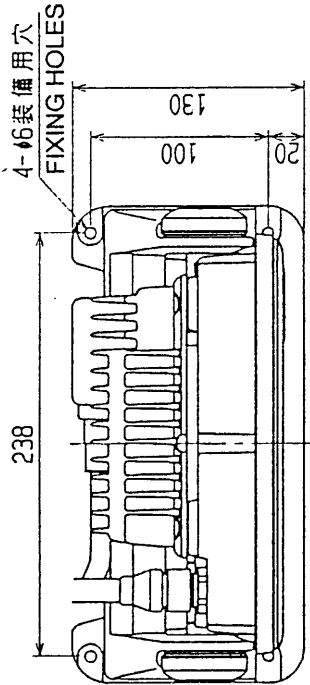

238

130

100

20

4-φ6 装備用穴
FIXING HOLES

MIN 80
SERVICING
CLEARANCE

266

236

268

250

MIN 80
SERVICING
CLEARANCE

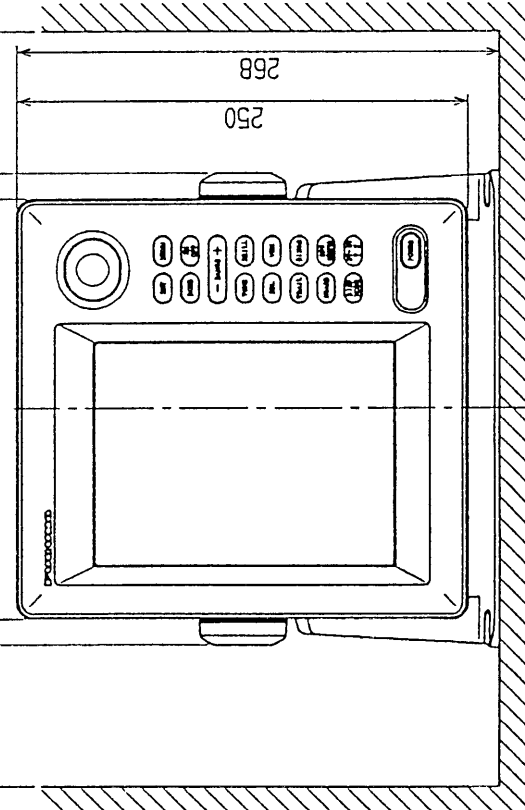

DRAWN
Aug 24, 1995
CHECKED
Mori moto
APPROVED
Aug 24 '95
SCALE
1/4
MASS
2.8 kg
DWG NO.
C3416-G01-B

TYPE
名称
RDP113/114
指示部
外寸図
NAME
RADAR DISPLAY UNIT
BLOCK NO.
03-129-1000- GO
APPLICABLE TO:
(MODEL)
FMD-811
MODEL 841
MODEL 821

OUTLINE DRAWING

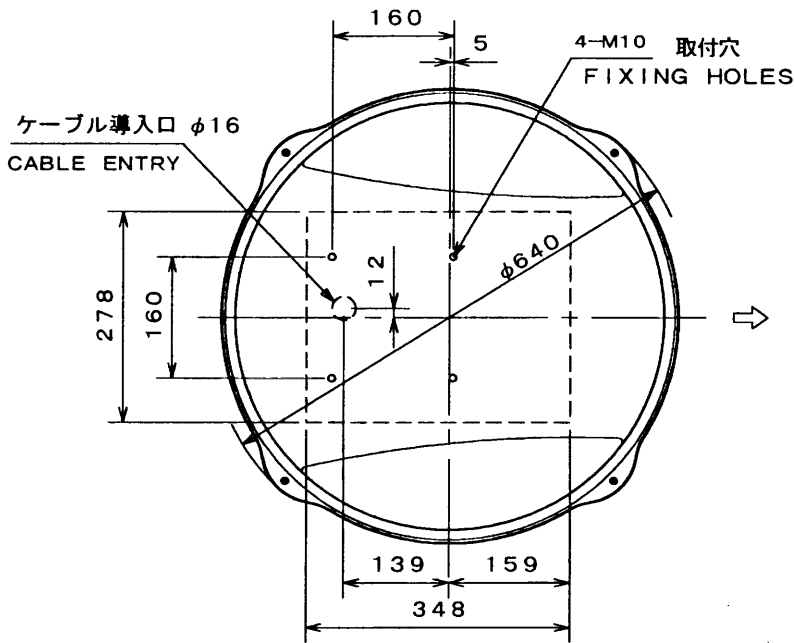

範囲 DIMENSION	公差 TOL
$L \leq 50$	$\pm 1\text{mm}$
$50 < L \leq 100$	$\pm 2\text{mm}$
$100 < L \leq 500$	$\pm 3\text{mm}$
$500 < L \leq 1000$	$\pm 4\text{mm}$
$1000 < L \leq 2000$	$\pm 5\text{mm}$
$2000 < L \leq 4000$	$\pm 7\text{mm}$
$4000 < L \leq 8000$	$\pm 10\text{mm}$
$8000 < L$	$\pm 15\text{mm}$

表 1

TABLE 1

SHIP'S BOW
船首方向

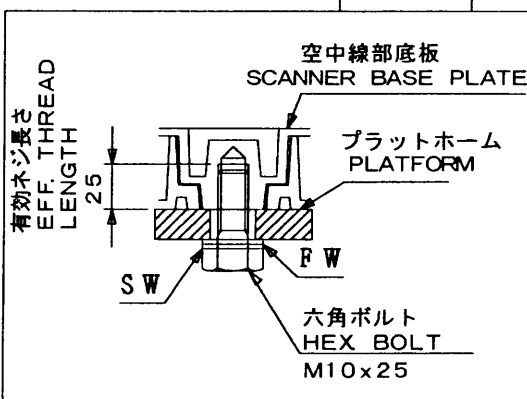
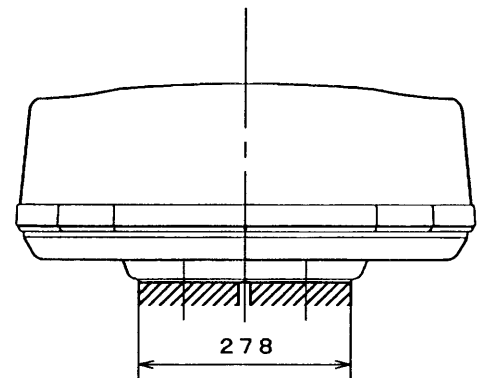
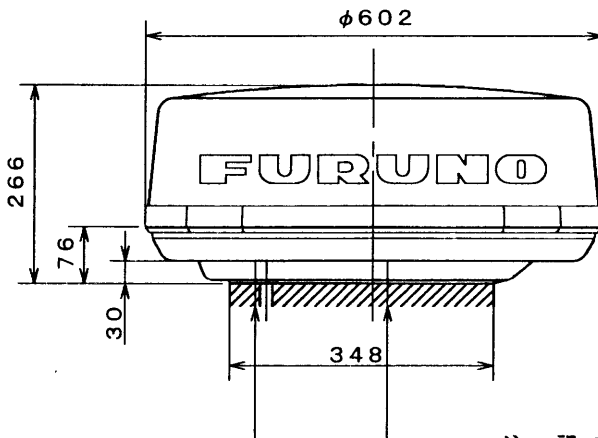

注 記 NOTE

- 1) 指定外の寸法公差は表1による。
TABLE 1 INDICATES TOLERANCE OF DIMENSIONS.
- 2) コンパス安全距離
COMPASS SAFE DISTANCE

STANDARD スタンダード	1.4m
STEERING ステアリング	1.1m

DRAWN Apr. 9 '98 T. YAMASAKI		TITLE RSB-0071
CHECKED Apr. 9 '98 K. Kusunoki		名称 空中線部
APPROVED Apr. 9 '98 K. Kusunoki	RS-1000 MODEL 1832	外寸図
SCALE 1/10	MASS 8±0.5kg	NAME SCANNER UNIT
DWG No. C3441-G01-C	03-136-6001-G2	OUTLINE DRAWING

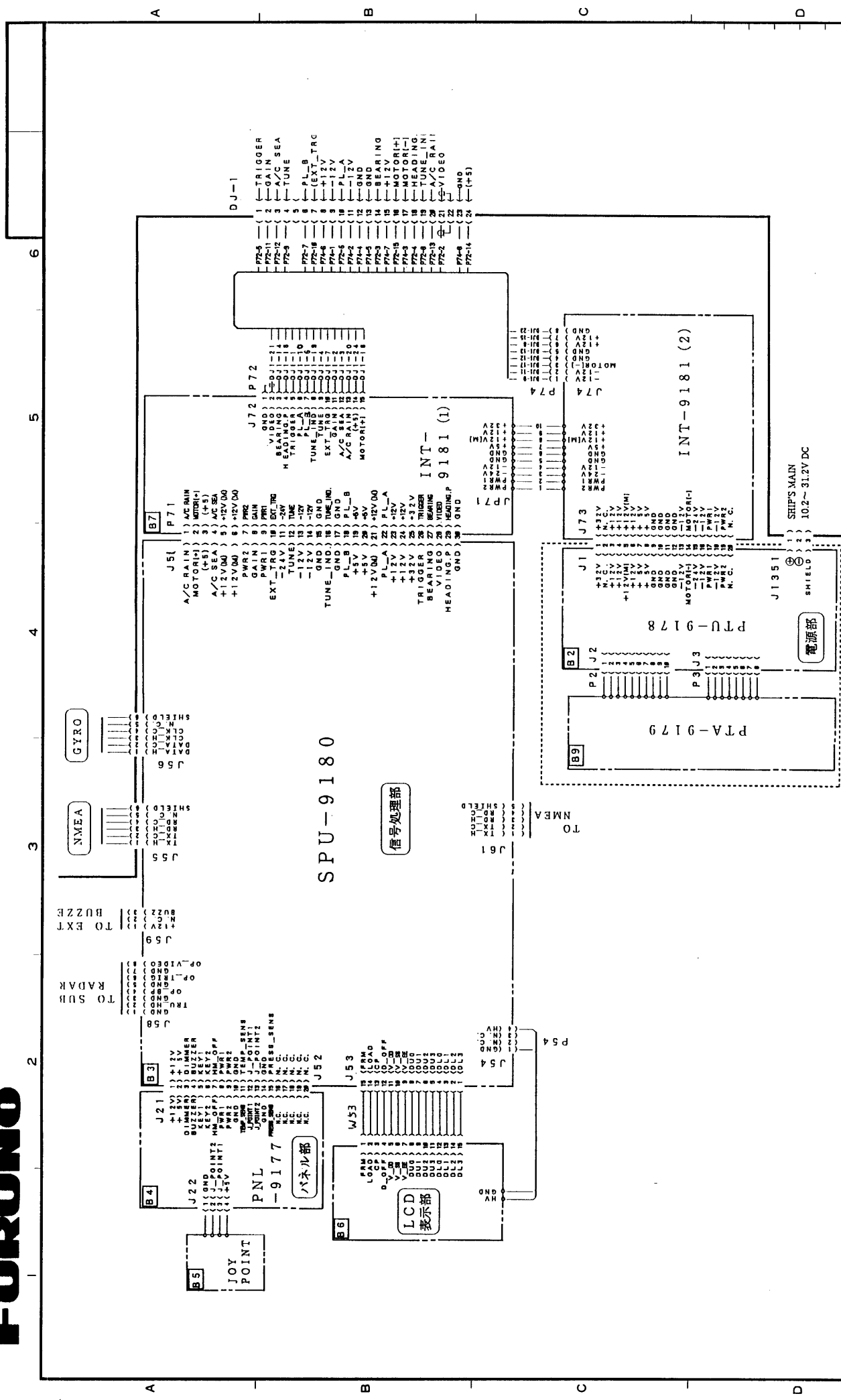

TYPE	RDP113
名称	指示部総合
名称	回路図
名称	DISPLAY UNIT GENERAL
名称	SCHEMATIC DIAGRAM
MODEL	M841M2
MODEL	MODEL 841
MODEL	MODEL 821
APPLICABLE TO:	
SCALE	1/kk
DRG NO.	C3416-K02-C
BLOCK NO.	03-129-6003-1

FURUNO ELECTRIC CO., LTD.

