

FURUNO

OPERATOR'S MANUAL

GPS NAVIGATOR

MODEL GP-500 MARK-2



FURUNO ELECTRIC CO., LTD.
NISHINOMIYA, JAPAN

©FURUNO ELECTRIC CO., LTD.

9-52, Ashihara-cho,
Nishinomiya, Japan

Telephone: 0798-65-2111
Telefax: 0798-65-4200

•Your Local Agent/Dealer

All rights reserved. Printed in Japan

FIRST EDITION : JAN 1993
R : SEP. 1, 1999

(TATA)

PUB. No. OME-43550
GP-500 MARK-2



* 0 0 0 8 0 4 7 8 0 0 0 *



SAFETY INSTRUCTIONS

"**DANGER**", "**WARNING**" and "**CAUTION**" notices appear throughout this manual. It is the responsibility of the operator and installer of the equipment to read, understand and follow these notices. If you have any questions regarding these safety instructions, please contact a FURUNO agent or dealer.



DANGER

This notice indicates a potentially hazardous situation which, if not avoided, will result in death or serious injury.



WARNING



This notice indicates a potentially hazardous situation which, if not avoided, could result in death or serious injury.



CAUTION

This notice indicates a potentially hazardous situation which, if not avoided, could result in minor or moderate injury, or property damage.

SAFETY INFORMATION FOR THE OPERATOR

 WARNING	
	<p>Do not open the cover of the equipment.</p> <p>This equipment uses high voltage electricity which can shock, burn or cause death. Only qualified personnel should work inside the equipment.</p>
	<p>Do not disassemble or modify the equipment.</p> <p>Fire, electrical shock or serious injury can result.</p>
<p>Immediately turn off the power at the ship's mains switchboard if water or foreign object falls into the equipment or the equipment is emitting smoke or fire.</p> <p>Continued use of the equipment can cause fire, electrical shock or serious injury.</p>	

 CAUTION	
<p>Do not place liquid-filled containers on the top of the equipment.</p> <p>Fire or electrical shock can result if a liquid spills into the equipment.</p>	
<p>Do not place heater near the equipment.</p> <p>Heat can melt the power cord, which can result in fire or electrical shock.</p>	
<p>Do not operate the unit with wet hands.</p> <p>Electrical shock can result.</p>	
<p>Use the correct fuse.</p> <p>Use of the wrong fuse can cause fire or equipment damage.</p>	
<p>No single navigation aid (including this unit should ever be relied upon as the exclusive means for navigating your vessel.</p> <p>The navigator is responsible for checking all aids available to confirm his position. Electronic aids are intended to assist, not replace, the navigator.</p>	

WARNING Label attached

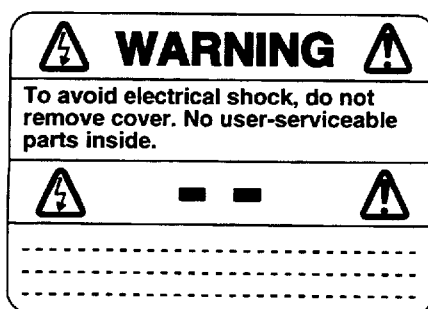

Name : Warning Label (1)
 Type : 86-003-1011-0
 Code No. : 100-236-230

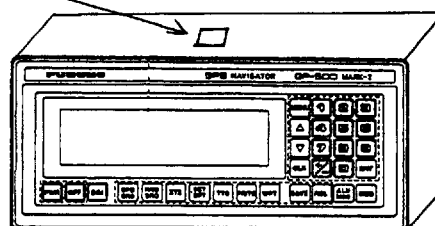



SAFETY INFORMATION FOR THE INSTALLER

WARNING



Only qualified personnel should work inside the equipment.

This equipment uses high voltage electricity which can shock, burn, or cause death.

Turn off the power at the ship's mains switchboard before beginning the installation. Post a warning sign near the switchboard to ensure that the power will not be applied while the equipment is being installed.

Serious injury or death can result if the power is not turned off, or is applied while the equipment is being installed.



CAUTION



Ground the equipment.

Ungrounded equipment can give off or receive electromagnetic interference or cause electrical shock.

Confirm that the power supply voltage is compatible with the voltage rating of the equipment.

Connection to the wrong power supply can cause fire or equipment damage. The voltage rating appears on the label at the rear of the equipment.

TABLE OF CONTENTS

TABLE OF CONTENTS BY MENU v

FOREWORD viii

Features	ix
How to Use this Manual	x

INTRODUCTION TO GPS 1-1

What is GPS?	1-1
Position-fixing accuracy (HDOP)	1-1

BASIC OPERATION 2-1

The Keyboard	2-2
Key description	2-2
Keyboard response conventions	2-3
Basic Operating Procedures	2-4
Turning the power on and off	2-4
Adjusting illumination and backlighting	2-4
Entering numeric data	2-4
Changing latitude and longitude coordinate	2-4
Clearing data	2-4
Terminating keyboard input	2-4
The Main Menu	2-5
Menu description	2-5
Basic menu operation	2-6
Basic Start-up	2-8
Turn on the power	2-8
Enter your estimated position	2-8
Enter antenna height	2-9
How to Read the Display	2-11
Saving Present Position	2-15
Man overboard position	2-15
Present position	2-15
Automatic position saving	2-16
Viewing Saved Positions	2-17

WAYPOINT NAVIGATION **3-1**

Registering Waypoints and Displaying Waypoint List ····	3-2
By latitude and longitude ······	3-2
By present position ······	3-5
By previously saved position ······	3-5
By range and bearing ······	3-6
By LOP ······	3-7
Displaying the waypoint list ······	3-7
Waypoint Navigation ······	3-9
Specifying present position as FROM waypoint ······	3-9
Specifying registered waypoints as FROM and TO waypoints ······	3-10
Canceling waypoint navigation ······	3-10
Navigation and steering information ······	3-11
Calculating Range and Bearing Between Two Points ····	3-17
Calculating TTG and ETA Between Two Points ······	3-19

ROUTE NAVIGATION **4-1**

Creating a Route ······	4-2
Deleting a Route and Route Contents ······	4-3
Registering Route 00 ······	4-5
Following a Route ······	4-8
Selecting a route ······	4-8
Connecting routes ······	4-10
Canceling route navigation ······	4-11

MISCELLANEOUS FUNCTIONS **5-1**

Selecting Geodetic Chart System ······	5-2
Standard GPS chart system ······	5-2
Chart systems stored in this unit ······	5-2
Selecting chart system ······	5-2
Entering Magnetic Variation ······	5-4
Changing Units of Measurement and Display Indications ··	5-5
Selecting Back-up Navigator ······	5-7
Initial Settings ······	5-9
Differential GPS ······	5-17
Initial settings ······	5-17
Data receiving status ······	5-19
Default Settings ······	5-20

ALARMS **6-1**

Timer, Stopwatch and Wake-up	6-2
Description	6-2
Selecting timer or stopwatch	6-2
Starting the stopwatch	6-3
Starting the timer	6-4
Anchor Watch, Arrival, Cross Track Error, Border, Speed, & Trip Alarm	6-5
Alarm description	6-5
How to set the alarms	6-6
Alarm Display	6-10
Alarm indications	6-10
Error indications	6-11
Displaying Full Alarm/Error Indication	6-12
No alarm	6-12
Alarm indication	6-12
System alarm	6-14

TROUBLESHOOTING **7-1**

Troubleshooting	7-2
Satellite Receiving Condition (SV Display)	7-4
Future Satellites Display	7-5
Testing the Unit for Proper Operation	7-6
Self test	7-6
Keyboard test	7-8
Clearing the Memory	7-9
Clearing all memories	7-9
Clearing data memories	7-9
Cold Start	7-11

INSTALLATION **8-1**

Display Unit Installaion	8-1
Antenna Unit Installation	8-2
Connections on the Display Unit	8-5
Entering Initial Data	8-6
Entering estimated latitude and longitude, antenna height	8-6
Selecting back-up navigator	8-7
Selecting speed log and gyrocompass	8-9
Selecting communication format	8-11
Autopilot connection	8-18
Connecting DGPS Beacon Receiver	8-20

Interface Documentation	8-21
“DATA IN” port	8-21
“DATA OUT” port	8-23
“DATA IN/OUT” port	8-25

APPENDIX

Specifications	A-1
Time Differences	A-3
Geodetic Chart Systems	A-4
Loran C/A Chains	A-5
Decca Chains	A-6
Equipment Lists	A-7

DRAWINGS

Interconnection Diagram	S-1
Schematic Diagrams	S-2
Outline Drawings (Display Unit, Antenna Unit)	D-1

INDEX

IDX-1

Declaration of conformity to type

Table of Contents by Menu

0 INIT DATA(1)			
├──	DATE		<u>Page</u>
├──	TIME		
├──	LOCAL ZONE TIME		
├──	LAT		
├──	LONG		
├──	POSITION MODE		
├──	ANTENNA HEIGHT		
├──	MASK ELEVATION		
		2-8, 8-16
1 TIMER			
├──	START	3-3, 6-4
2 TIMER SET			
├──	MODE SELECT	├──	TIMER WATCH
├──	WAKE UP TIME		
├──	BUZZER		
		6-2
3 WAYPOINT			
├──	0:WAYPOINT LIST	3-7
├──	1:CALCULATION(1)	├──	FROM WPT
		├──	LAT/LONG
		├──	TO WPT
		├──	LAT/LONG
		├──	RESULTS RHUMB LINE•GREAT CIRCLE
		3-17
├──	2:R/B TO WAYPOINT	├──	FROM WPT
		├──	LAT/LONG
		├──	TO WPT
		├──	LAT/LONG
		├──	RANGE
		├──	BEARING
		3-6
├──	3:CALCULATION(2)	├──	FROM WPT
		├──	LAT/LONG
		├──	TO WPT
		├──	LAT/LONG
		├──	SPD
		├──	TTA•ETA
		3-19
4 VOYAGE PLAN			
├──	FROM WPT		
├──	TO WPT		
├──	NO OF WPT		
├──	SPD FOR CALC		
├──	ROUTE NUMBER		
├──	RESULTS		
		4-5

5 ROUTE

0:ROUTE PLAN	4-2
1:ROUTE SELECT	4-8
2:ROUTE CONNECT	4-10

6 ALARM

0:ALARM	<ul style="list-style-type: none"> ANCHOR WATCH/ARRIVAL ACTIVATE XTE/BORDER ACTIVATE ALARM BUZZER MAX SPEED MIN SPEED MONITOR TRIP RANGE MONITOR NAV ALARM BUZZER 	6-6
1:DISTANCE RUN	3-16, 6-13	

7 FUTURE SATELLITE 7-5

8 DIFFERENTIAL DATA

0:INITIAL DATA	<ul style="list-style-type: none"> D GPS MODE RTCM VERSION BYTE FORMAT FIRST BIT PARITY BIT STOP BIT BIT RATES BAUD RATES 	5-16
1:DGPS STATUS MONITOR	— DATA RECEIVE	5-18

9 SYSTEM DATA

0:INIT DATA(2)	<ul style="list-style-type: none"> L/L CORRECTION L/L SMOOTHING S/C SMOOTHING AVE S/C SMOOTHING DISABLED SATS DISABLE SAT SELECT 	5-9
	<ul style="list-style-type: none"> LC <ul style="list-style-type: none"> GRI LOP1 LOP2 LOP1 CORRECTION LOP2 CORRECTION LA <ul style="list-style-type: none"> LOP1 LOP2 LOP1 CORRECTION LOP2 CORRECTION DEC <ul style="list-style-type: none"> LOP1 LOP2 LOP1 CORRECTION LOP2 CORRECTION OFF..... 	5-12
		5-13
		5-14
		5-12

9 SYSTEM DATA

0:INIT DATA (2)	<ul style="list-style-type: none"> BACK UP NAV BUZZER FORCED SAT FORCED SAT IS CLK CORRECTION 	5-15
1:DATUM SELECT		5-2
2:LOG GYRO DATA	<ul style="list-style-type: none"> LOG SPD LOG IN LOG PULSE (IN) LOG PULSE (OUT) GYRO HDG SET/DFT SMOOTHING 	5-7、 8-9
3:BACK UP NAV SELECT	<ul style="list-style-type: none"> BACK UP NAV GPS POSN CORRECT GPS COR SMOOTHING GPS CORRECT VAR 	5-7、 8-17
4:MAGNETIC VARIATION	<ul style="list-style-type: none"> VARIATION VARIATION VAL 	5-4
5:DISPLAY UNIT	<ul style="list-style-type: none"> LAT. LONG RESO RNG. BRG CALC HEIGHT UNIT RNG. SPD UNIT BAR GRAPHIC VTD/BRG/RNG 	5-5
6:COLD START	<ul style="list-style-type: none"> ALMANAC D.T COLD START SV NUMBER 	7-11
7:SV CONDITION		7-4
8:SELF TEST	<ul style="list-style-type: none"> 0:SELF TEST 1:KEYBOARD TEST 2:MEMORY CLEAR 	7-6 7-8 7-9
9:I/O DATA FORMAT	<ul style="list-style-type: none"> 0:DATA IN CONNECTOR 1:DATA OUT CONNECTOR 2:D.IN/OUT CONNECTOR 3:AUTO PILOT DATA 	8-12 8-13 8-17 8-18

FOREWORD

Congratulations on your choice of the FURUNO GP-500 MARK-2 GPS Navigator. We are confident you will see why the FURUNO name has become synonymous with quality and reliability.

For over 40 years FURUNO Electric Company has enjoyed an enviable reputation for innovative and dependable marine electronics equipment. This dedication to excellence is furthered by our extensive global network of agents and dealers.

Your unit is designed and constructed to meet the rigorous demands of the marine environment. However, no machine can perform its intended function unless properly installed and maintained. Please carefully read and follow the installation, operation and maintenance procedures set forth in this manual.

We would appreciate hearing from you, the end-user, about whether we are achieving our purposes.

Thank you for considering and purchasing FURUNO equipment.

NOTICE: *No single navigational aid (including this unit) should ever be relied upon as the exclusive method for navigating your vessel. The navigator is responsible for checking all aids available to confirm his position. Electronic aids are meant to assist the navigator.*

Features

The GP-500 MARK-2 consists of two units: an antenna unit and a display unit. The high sensitivity, eight channel receiver tracks up to eight satellites simultaneously. An 8-state Kalman filter ensures optimum accuracy in determination of vessel position, course and speed.

Navigation data is presented on a 240 × 64 dot matrix backlit LCD. Data shown are ship's position in latitude and longitude, speed and course, range and bearing to a waypoint, etc.

In most cases the operator need do no more than turn on the power to find his or her position.

The unit operates from any 10 to 40 Vdc power supply. 100 V, 110 V, 200 V or 220 Vac, 50/60 Hz operation also is available by an optional rectifier. Power consumption is 12 W.

The GP-500 MARK-2's compact size belies the multitude of features contained inside. The main features are as follows.

- Compact display unit permits installation where space is limited
- Comprehensive display of navigation data
- Storage for up to 200 waypoints
- Reception of data from DGPS beacon receiver in RS-232C or RS-422
- Navigation planning from/to waypoint or routes
- Alarm functions -- Arrival alarm, Anchor Watch alarm, Cross Track Error alarm, Border alarm, Ship's Speed alarm, Trip alarm
- Man overboard feature records latitude and longitude coordinates at time of man overboard and provides continuous updates of the range and bearing to that point
- Built-in self diagnosis

How to Use this Manual

This manual is laid out in as “user-friendly” a manner as possible. A sophisticated instrument such as this, with its many, many functions can be very intimidating to the first-time user. It is our intention to guide the user along in the use of the gear as gently and as comfortably as possible in a series of sections that start at a very basic level and proceed forward in complexity in a logical manner.

This manual is arranged as follows:

Chapter 1 provides an introduction to GPS.

Chapter 2 covers basic operations. In most cases all you need to do to fix your position is turn on the power.

Chapter 3 explains waypoint navigation. A waypoint is the most basic information required to find information such as range and bearing from your vessel to a point.

Chapter 4 provides the information necessary for route navigation. A route is a sequence of waypoints leading to your ultimate destination.

Chapter 5 covers miscellaneous functions, such as how to enter earth’s magnetic variation and how to display position in Loran TDs.

Chapter 6 describes the alarm functions.

Chapter 7 provides troubleshooting information. Whenever you feel your unit is not operating properly, refer to this chapter.

Chapter 8 covers installation.

The **Appendix** contains specifications, time differences map, geodetic chart systems stored in this unit, etc.

INTRODUCTION TO GPS

What is GPS?

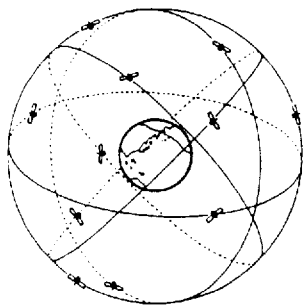

Figure 1-1 The orbits of GPS satellites

GPS is an acronym meaning Global Positioning System. GPS (sometimes referred to as NAVSTAR) is a highly precise satellite navigation system developed by the U.S. Department of Defense.

When full global coverage becomes available, a constellation of 24 satellites emplaced in nearly 20,000-kilometer high 12-hour circular orbits will provide highly precise, continuous, worldwide, all-weather position plus time and velocity information to GPS receiver-equipped vehicles, vessels and aircraft.

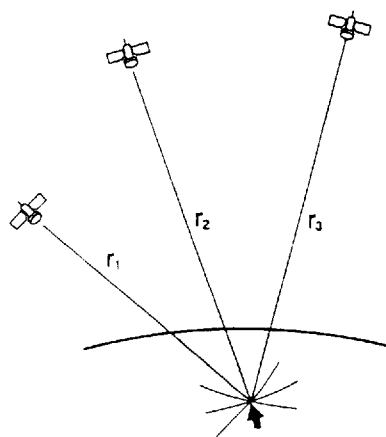

Figure 1-2 How the GPS receiver finds its position

The GPS receiver's position is continuously fixed by receiving 3 (or 4) satellites in line-of-sight of the GPS receiver. The basic steps in position fixing are as below.

1. GPS satellites continually transmit their own precise orbital data called ephemeris. The GPS receiver computes satellites' position by this data.
2. The GPS receiver measures very accurate distance to the satellites.
3. Satellite locations and their distances from the GPS receiver are known. The GPS receiver fixes its own position by triangulation.

Position-fixing accuracy (HDOP)

In radar position-fixing, most accurate position fixes are obtained when the targets used are spaced nearly 90 degrees from each other. Similarly, GPS position fixing accuracy is subject to satellite location. Generally, the further apart the satellites are from one another, the greater the position-fixing accuracy.

For example, take a look at Figure 1-3. In both situations a fix is obtainable in the Northern Pacific region because three satellites are in line-of-sight. However, accuracy will be higher in the right-hand figure since the satellites are spread farther apart than the satellites in the left-hand figure.

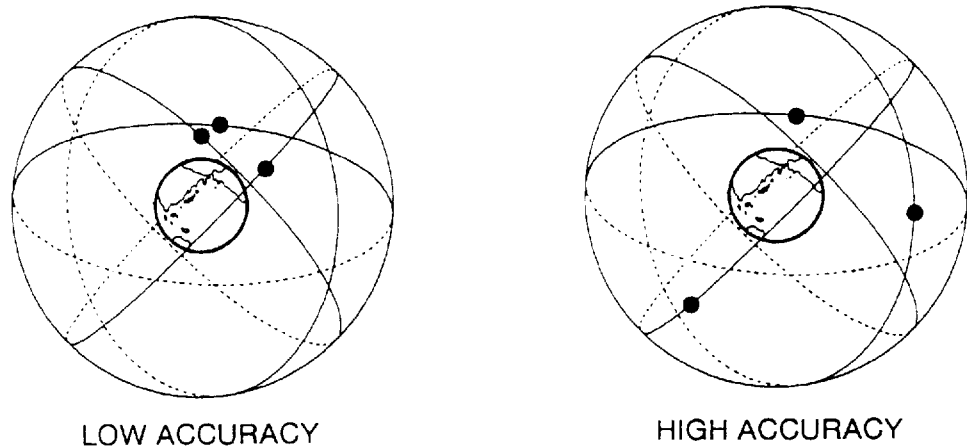
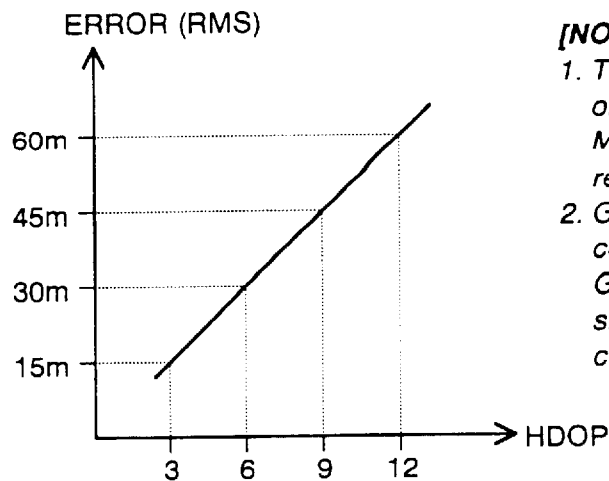

Figure 1-3 Satellite positions and accuracy of position fix

The index for position-fixing accuracy is known as HDOP (Horizontal Dilution of Precision). In simpler terms it is the geometrical relationship among 3 (or 4) satellites. The higher the HDOP value the less accurate the position fix. The error in distance is proportional to the HDOP value as shown in Figure 1-4.



[NOTE]

1. The error shown is observed on the GP-50 MARK-2 under favorable receiving conditions.
2. GPS accuracy is controlled by the US Government. The error shown is subject to change.

Figure 1-4 HDOP rate and position error

■ **NOTE:** In this manual HDOP is referred to as DOP.

BASIC OPERATION

This chapter provides basic operating information, from turning on the power to saving present position.

The first time the GP-500 MARK-2 is turned on it needs about 2 minutes to fix its position. This is because there is no almanac stored in the unit. Subsequent power applications require about 20 seconds.

If the position displayed when turning on the power is more than 10 degrees (about 600 miles) different from your actual position you should enter your estimated position, to find your exact position much quicker.

The Keyboard

The keyboard consists of 30 color-coded keys. Each time you press a key the associated reaction can be seen on the screen almost immediately.

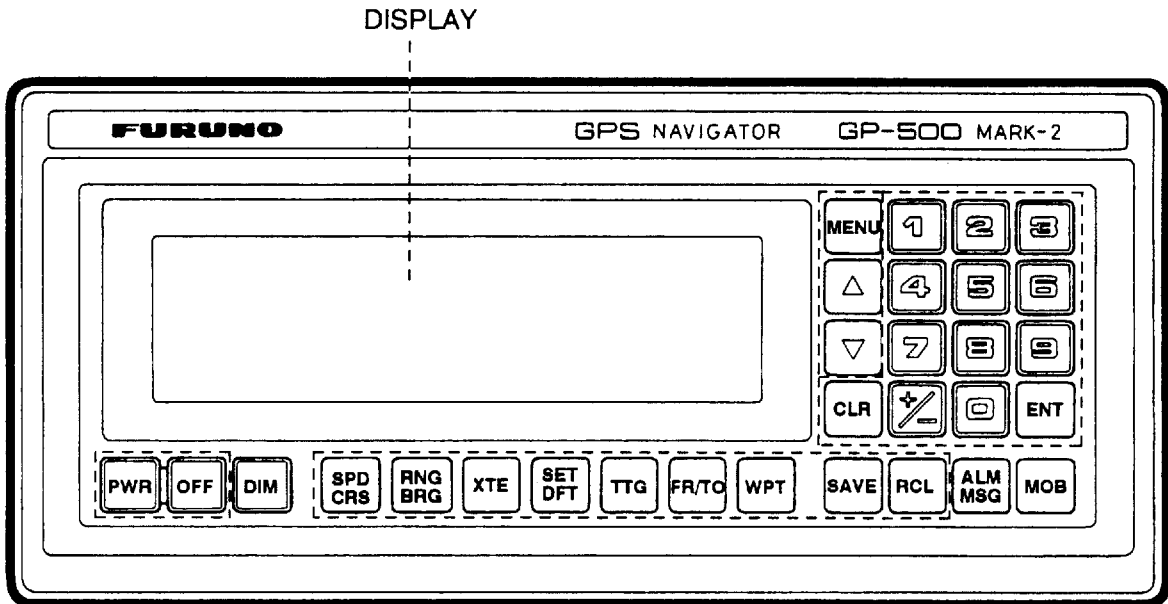

Figure 2-1 GP-500 MARK-2 Display Unit

Key description

Table 2-1 describes the function of each key.

Table 2-1 Key description

Key	Function
MENU	Display menu.
0 to 9	Enter numeric data.
▲▼ (Arrow)	Set cursor on line where to enter data.
CLR	Clear wrong or previously entered data.
+/-	Change coordinate from North to South, East to West, or vice versa.

Key	Function
ENT	Terminate keyboard input.
PWR	Turn on the power.
OFF	Press together with PWR to turn power off.
DIM	Adjut keyboard backlighting and LCD brightness.
SPD CRS	Display speed and course.
RNG BRG	Display range and bearing from present position to TO waypoint.
XTE	Display cross track error from present position to TO waypoint.
SET DFT	Display speed and direction of water current.
TTG	Display time-to-go (and estimated time of arrival) from FROM waypoint to TO waypoint.
FR/TO	Select FROM and TO waypoints.
WPT	Register waypoint.
SAVE	Save present position.
RCL	Display saved position.
ALM MSG	Display alarm source.
MOB	Mark man overboard position.

Keyboard response conventions

Each time you press a key the unit emits a beep tone according to operation executed.

- High tone beep -- Key input accepted.
- Low tone beep -- Invalid key input.

Basic Operating Procedures

Turning the power on and off

To turn the power on, press the **PWR** key.

To turn the power off, press the **PWR** and **OFF** keys together.

Adjusting illumination and backlighting

Press the **DIM** key to adjust the backlighting of the keyboard and the brightness of the LCD, in four levels.

Entering numeric data

Press numeric keys **0** - **9**.

Changing latitude and longitude coordinate

Press **+/-** to change North to South, East to West, or vice versa.

Clearing data

Before entering any data you press the **CLR** key to clear previous data. This key can also be used to clear wrong data.

Terminating keyboard input

Press the **ENT** key.

The Main Menu

Many functions of the GP-500 **MARK-2** are carried out through the main menu. Press the **MENU** key to display the main menu. The main menu consists of nine sub menus, numbered 0 through 9.

M E N U	
SELECT NUMBER : 0~9	
0 : INITIAL DATA (1)	5 : ROUTE
1 : TIMER	6 : ALARM
2 : TIMER SET	7 : FUTURE SATELLITES
3 : WAYPOINT	8 : DIFFERENTIAL DATA
4 : VOYAGE PLAN	9 : SYSTEM DATA

Figure 2-2 Main menu

Menu description

Table 2-2 provides a brief description of the menus.

Table 2-2 Menu description

Menu	Function
0: INITIAL DATA (1)	Enter initial setting such as estimated position and antenna height.
1: TIMER	Start the timer/stopwatch.
2: TIMER SET	Preset timer/stopwatch and wake-up time.
3: WAYPOINT	Register waypoints.
4: VOYAGE PLAN	Determine the shortest course between two waypoints.
5: ROUTE	Register and select route.
6: ALARM	Preset alarm ranges.
7: FUTURE SATELLITES	Display satellite schedule.
8: DIFFERENTIAL DATA	Enter DGPS data. Display DGPS receive status.
9: SYSTEM DATA	Enter system data such as magnetic variation and geodetic chart system.

Basic menu operation

The procedure which follows describes how to select a menu and enter data on a menu display.

- 1) Press the **MENU** key.

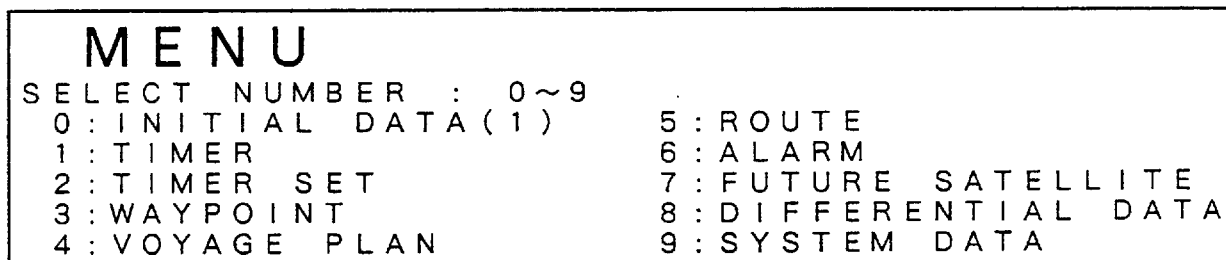

Figure 2-3 Main menu

- 2) Enter menu number with numeric keys. For example, press **0** for the INITIAL DATA (1) menu. The menu shown in Figure 2-4 appears.

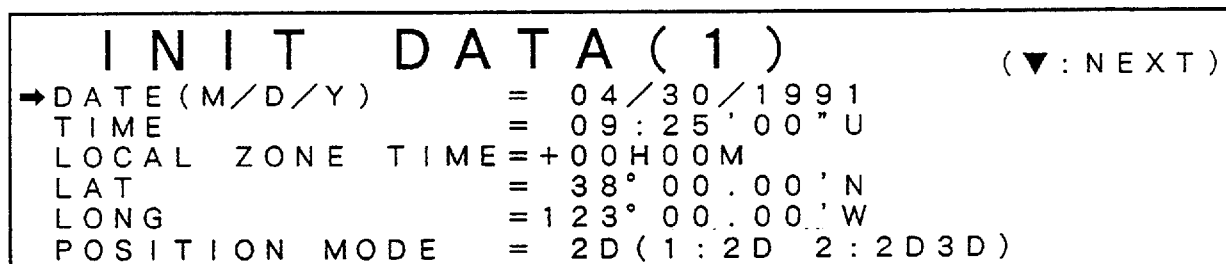

Figure 2-4 INIT DATA (1) menu

- 3) Press **▲** and **▼** keys to select line where you want to enter data. To enter latitude on the "LAT" line, for example, press **▼** three times to set the cursor on the LAT line. Your display should show the cursor on the LAT line, as in Figure 2-5.

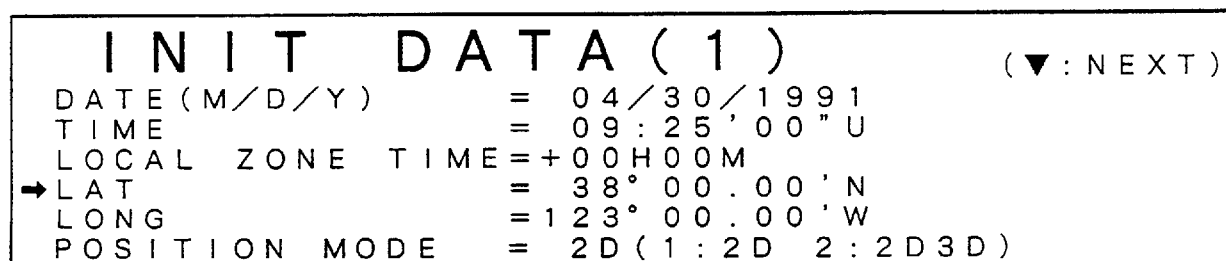

Figure 2-5 INIT DATA (1) menu

- 4) Press appropriate numeric keys to enter data. For example, to enter 5° 21.34' South latitude, press the following keys.

CLR **0** **5** **2** **1** **3** **4** **+/-** **ENT**

NOTE 1: *Arrow starts and stops blinking when **CLR** and **ENT** are pressed, respectively.*

NOTE 2: *Entry of leading zeroes is necessary.*

- 5) To enter data elsewhere on the current screen, press **▲** or **▼** to select line, and then enter data.

To escape, press **MENU** or any blue key.

Basic Start-up

Once initial settings are entered you need do no more than turn on the power to fix your position. If initial settings have not been entered, enter them by referring to the installation chapter.

Turn on the power

Press the **PWR** key to turn on the power. If this is the initial power application after installation the unit takes between 2 and 3 minutes to find its position. Subsequent power applications require about 20 seconds.

- When you turn on the power, "PF" (Power Failure) appears and blinks on the display. This does not mean equipment trouble. It will disappear upon pressing a key.
- If "BACK UP DATA ERROR" appears, see page 6-15.

Enter your estimated position

This is normally not required. If your position is more than 10 degrees different from the displayed position, however, enter your estimated position (within 10 degrees) as follows.

- 1) Press **SPD CRS** to confirm position. Then, press **MENU** and **0**.

INIT DATA (1)		(▼:NEXT)
→ DATE (M/D/Y)	= 04/30/1991	
TIME	= 0:25'00" U	
LOCAL ZONE TIME	= +09H00M	
LAT	= 34° 44.00' N	
LONG	= 123° 00.00' W	
POSITION MODE	= 2D (1:2D 2:2D3D)	

Figure 2-6 INIT DATA (1) display (first page)

- 2) Press **▼** three times to advance the cursor to the LAT line.
- 3) Enter estimated latitude by pressing the following keys.

CLR ° . ' (**+/-**)

- 4) Press the **ENT** key.
- 5) Press **▼**.

6) Enter estimated longitude by pressing the following keys.

CLR ° ' (**+/-**)

7) Press the **ENT** key.

Enter antenna height

Correct input of the antenna height above the waterline is essential for accurate determination of position. If not already entered, enter it as follows.

8) Press the twice to advance the cursor to the ANTENNA HEIGHT line.

I N I T D A T A (1)	(▼ : NEXT)
→ ANTENNA HEIGHT = 5 m (- 9 9 9 ~ 9 9 9 9) MASK ELEVATION = 5 ° (0 5 ~ 9 0)	

Figure 2-7 INIT DATA (1) display (second page)

9) Enter antenna height above the waterline in meters, using four digits. If the height is 15 meters, for example, press

CLR **0** **0** **1** **5**.

10) Press the **ENT** key.

11) Press the **SPD CRS** key to return to the position display.

The display shows “C ST,” “ACQ” and “2D” in that order. “2D” is short for two-dimensional and appears when position information is reliable. It appears about 20 seconds after turning on the power in daily start-up.

NOTE 1: “MASK ELEVATION” on the INIT DATA (1) display should not be changed. The default setting of 5 degrees provides excellent performance under all conditions. Adjustment may greatly lessen available GPS position fixing time.

NOTE 2: Input of time and date is not necessary. When you receive a satellite signal the correct date and time appear on the display.

NOTE 3: *You can display time in UTC or local time. (The default setting is UTC.) If you prefer local time, enter time difference between your time and UTC on the “LOCAL TIME ZONE” line. If your time is earlier than UTC enter a minus sign before entering time difference. See page A-4 for reference.*

NOTE 4: *The default setting for “POSITION MODE” is 2D; that is, for marine vessels. For land vehicles, change to 2D3D. At the 2D3D mode, the two-dimensional position fix (2D) and three-dimensional position fix (3D) are automatically switched according to how many satellites are in line-of-sight; three satellites for 2D and four satellites for 3D. Also, when PDOP value exceeds 6 in the 3D mode, the position-fixing method is automatically changed to 2D.*

How to Read the Display

Any one of the five keys bracketed in Figure 2-8 show position when pressed.

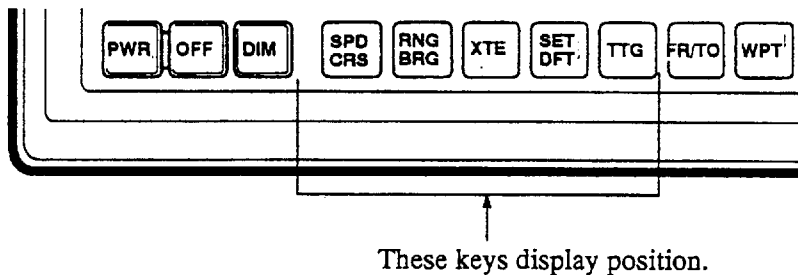

Figure 2-8 Keyboard, showing keys which display position

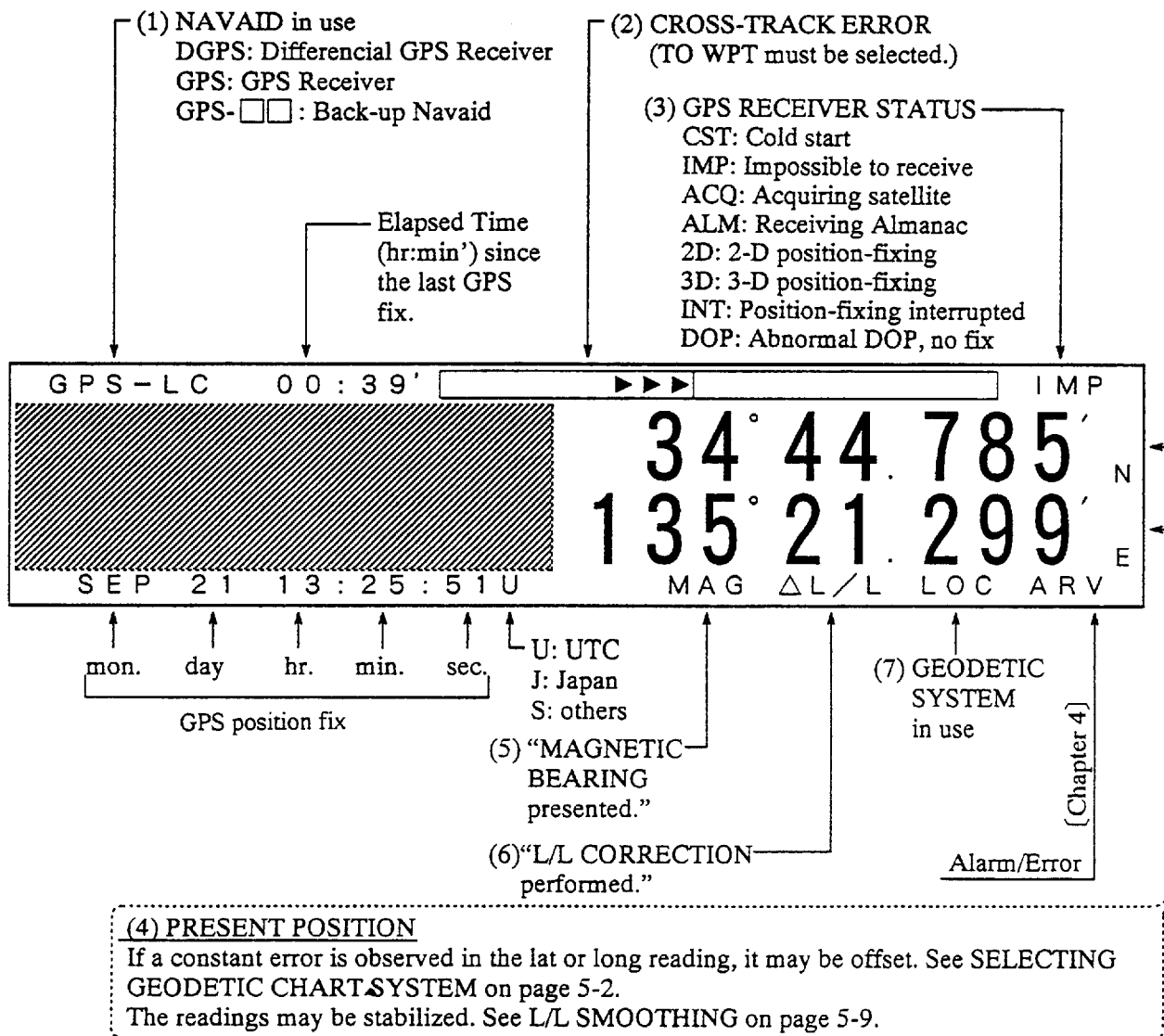

Figure 2-9 Typical position display

Detailed descriptions of items 1 through 7 in Figure 2-9 follow.

① **Position-fixing system in use**

Abbreviations	Meaning
GPS	Position fixing by GPS. The unit generates three beeps when GPS position fixing is no longer unavailable. (You can disable the buzzer if not required. More on this in a later chapter.)
GPS-A	Position fixing by dead reckoning; namely, speed log and gyrocompass.
GPS-M	Position fixing by manually entered speed and heading information.
*GPS-DR	Position fixing by satellite navigator.
*GPS-LC	Position fixing by Loran C receiver.
*GPS-LA	Position fixing by Loran A receiver.
*GPS-OM	Position fixing by Omega receiver.
*GPS-DC	Position fixing by Decca receiver.
DGPS	Position fixing by DGPS.
— — —	No external navigator connection. (No fix)

NOTE: *The asterisk appears when no position correction is applied.*

② **Cross track error**

Cross track error is displayed with arrowheads. Up to ten arrowheads appear according to amount of cross track error. One arrowhead is equivalent to 0.02 nautical miles.

Course error

Course error between TO waypoint and your vessel's heading may be shown instead of cross track error. One arrowhead is equal to three degrees of course error.

To return your vessel to the intended track or course, steer in the direction indicated by the arrowheads.

③ Receiver status

Abbreviations	Meaning
C ST	This indication appears on the first power on after installation and means there is no almanac inside the unit. The unit automatically starts acquiring a satellite to receive the almanac. If you know a satellite which is within line-of-sight, conduct cold start as prescribed on page 7-11.
IMP	Impossible to receive. (A satellite is not available within line-of-sight.)
ACQ	The unit is acquiring a satellite. If the "ACQ" indication remains on the screen for a long time (without being replaced by ALM, 2D or 3D), suspect that the satellite is not being received normally.
ALM	The unit is receiving the almanac. According to the almanac in the GP-500 MARK-2 three satellites (four in case of 3D) are not yet available within line-of-sight. Since it cannot fix its position, the GP-500 MARK-2 is receiving the almanac.
2D or 3D	Two dimensional or three dimensional position fixing.
INT	Position fixing is interrupted. Objects near the GPS antenna are interrupting reception of satellites. Position fixing is resumed when lost satellite reappears.
DOP	When HDOP exceeds 4 in the 2D mode or PDOP exceeds 6 in the 3D mode, DOP value becomes abnormal and position fix is not reliable. The GP-500 MARK-2 automatically switches to the 2D mode when the PDOP exceeds 6 in the 3D mode.

④ Position

Latitude and longitude appear in the resolution level of either 0.01 or 0.001, depending on setting described on page 5-5. In case of 3D position fixing mode the antenna height above the waterline also appears.

⑤ Magnetic variation correction

“MAG” appears when the bearing is corrected by magnetic variation. No “MAG” means all bearings are true.

⑥ Latitude and longitude correction

Δ L/L appears to inform you to that latitude and longitude corrections are being applied to GPS position. (The GP-500 MARK-2 applies position correction only to GPS position.)

⑦ Geodetic system

“LOC” appears when a geodetic chart system other than WGS-84 is selected.

Saving Present Position

Man overboard position Press the **MOB** key to mark man overboard position. The display should look something like Figure 2-10.

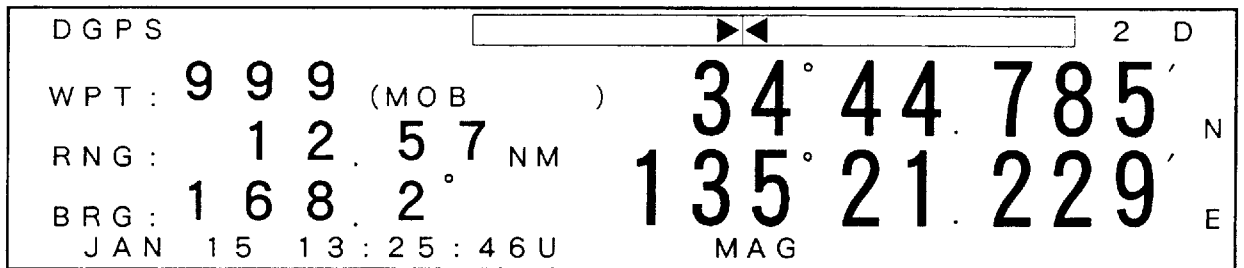

Figure 2-10 Typical man overboard display

The unit saves the position, time and date as "999." The range and the bearing from present position to the man overboard position are continually calculated, so you can easily return there. Figure 2-11 illustrates the man overboard feature.

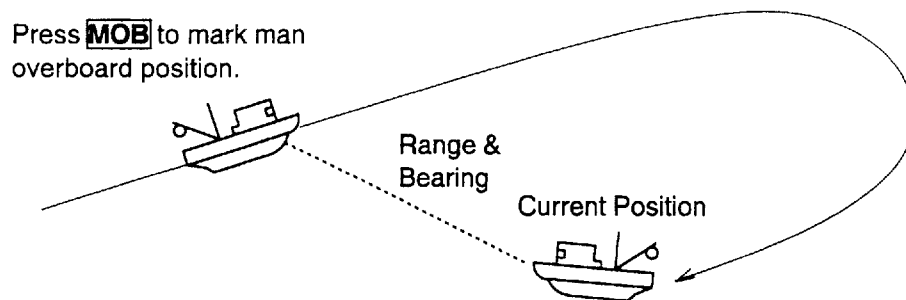

Figure 2-11 The man overboard feature

Present position

There will be times when you will want to save your present location on a temporary basis. (For permanent storage, register position as a waypoint. Waypoints will be dealt with in the next chapter.) For example, you have laid some crab pots, and want to return to the location at a later time.

You can save up to 20 present locations. The unit numbers the locations from 200 to 219. If you try to save more than 20 locations, the earliest locations will be deleted, one at a time, to make room for the latest positions.

Press the **SAVE** key. The moment the key is pressed the position of your vessel is stored in the memory. Figure 2-12 shows a typical SAVE INTO display.

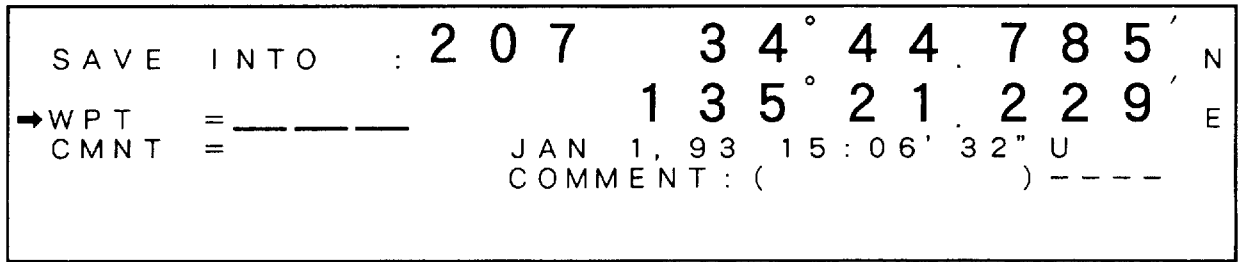

Figure 2-12 Typical SAVE INTO display

In the next chapter you will learn how to save present position as a waypoint.

Automatic position saving

This unit automatically saves the vessel's position on the hour. It numbers these locations from 300 to 319.

Viewing Saved Positions

You may view both manually and automatically saved positions by pressing the **RCL** key. Each time you press the key the position saved appears in the following sequence.

999→••201→200→999→319→••300→219→218→••

→RECALL FROM=	2 0 7	3 4°	4 4 .	7 8 5'	N
WPT =	_____	1 3 5°	2 1 .	2 2 9'	E
CMNT =	_____	JAN 11, 93	15:06	'32" U	
		COMMENT: () GPS	

Figure 2-13 RECALL FROM display, showing manually saved position

WAYPOINT NAVIGATION

This chapter provides the information necessary for waypoint navigation. A waypoint is a particular location on a voyage, whether it be a starting point, an intermediate point or a destination point. Using a waypoint, the GP-500 MARK-2 can calculate various navigation information from the present position to the waypoint. These are

- range and bearing
- ideal course
- velocity to destination
- estimated time of arrival
- time-to-go, and
- cross track error or course error.

Registering Waypoints and Displaying Waypoint List

This unit has 199 waypoints into which you can enter position information. It numbers waypoints from 001 to 199.

Obviously, it's important that you write down your waypoints in a log so you have a permanent record of which waypoint is which.

There are five methods by which you can enter a waypoint:

- by latitude and longitude
- by present position
- by previously saved position
- by range and bearing from a previously registered waypoint, and
- by LOP (Line of Position) values for Loran C, Loran A or Decca.

By latitude and longitude

- 1) Press the **WPT** key. The display shown in Figure 3-1 appears.

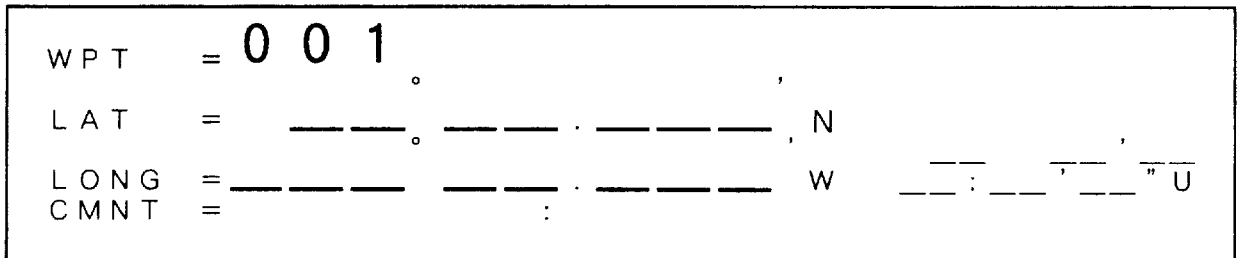

Figure 3-1 WPT display (no data)

- 2) Enter waypoint number (001 to 199).

CLR

- 3) Press the **ENT** key.

NOTE: If "LOCK" or "IN USE" appears on the display, this means the waypoint number is write protected or is selected as TO or FROM waypoint, respectively. For how to overwrite the waypoint number, see page 3-4.

- 4) Press .

5) Enter latitude.

CLR ° . '

6) Select coordinate polarity, North or South, by pressing **+/-**.

7) Press the **ENT** key.

8) Press the **▼**.

9) Enter longitude.

CLR ° . '

10) Select coordinate polarity, East or West, by pressing **+/-**.

11) Press the **ENT** key.

12) Press the **▼** key. The cursor moves to "CMNT."

→ CMNT =
A B C D E F G H I J K L M N O P Q R S T U V W X Y Z F I N I S H

13) You may enter a comment to help you identify the waypoint. The comment may consist of up to eight alphanumeric characters. To enter a comment;

- (1) Press the **CLR** key. A highlighted cursor appears on character "A."
- (2) The following numeric keys serve to move the cursor. Operate them to place the cursor on the character you want to enter. If the first character of your comment is "E," for example, press the [6] key four times to select "E."

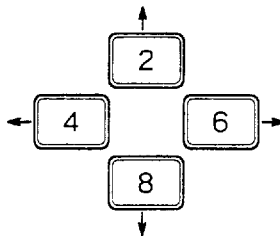

NOTE: Below are all the characters which can be entered for a comment. These characters appear on two pages. Use the [2] and [8] keys to scroll the display.

0 1 2 3 4 5 6 7 8 9 + - ; # ? \$ % & = ~ * ! / _
A B C D E F G H I J K L M N O P Q R S T U V W X Y Z

- (3) Press the **ENT** key. The character selected appears on the prompt line.
- (4) Repeat steps 2 and 3 to complete the comment.
- (5) Press [6] to place the cursor on "FINISH."
- (6) Press the **ENT** key.

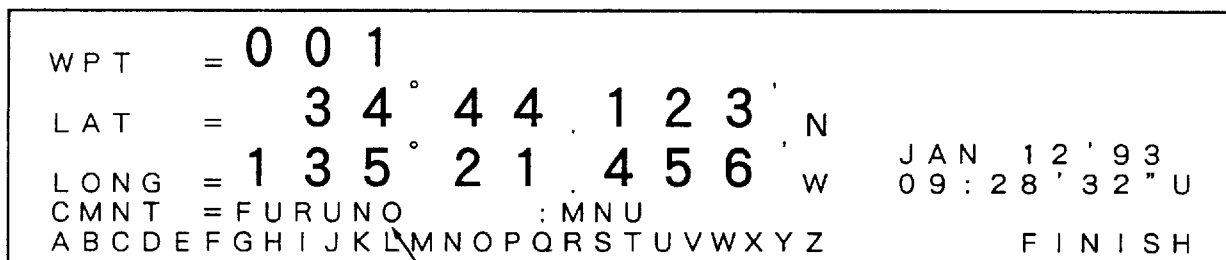

Figure 3-2 Typical WPT display

Write-protecting waypoints

You can write protect a waypoint as follows.

- 14) Press **▲** or **▼** to place the cursor on the first line.
- 15) Enter waypoint number (001 to 199) you want to write protect as follows;

CLR **+/-**

Each press of the **+/-** key alternately displays and erases the indication "LOCK."

- 16) Press the **ENT** key.

NOTE: As noted earlier the indication "LOCK" means a waypoint is write protected and respectively. You can disable the write protection on a waypoint by entering its number and then pressing the **+/-** key twice to erase "LOCK." "IN USE" means the waypoint is being used in waypoint navigation, or as a starting point or waypoint when following a route.

By present position

1) Press the **SAVE** key. The display should look something like Figure 3-3.

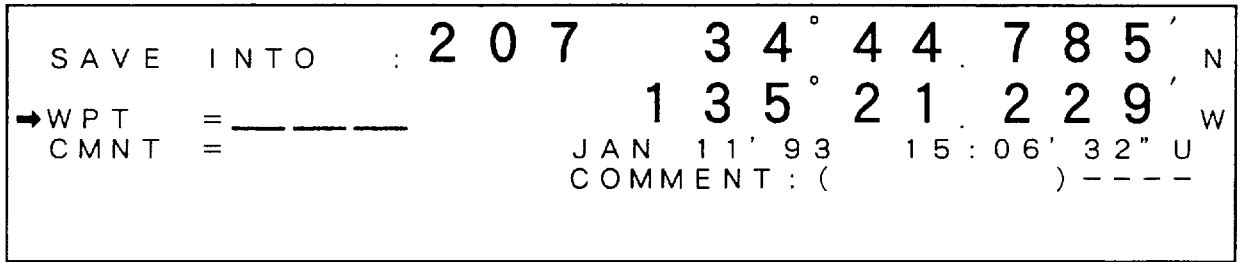

Figure 3-3 Typical SAVE INTO display

- 2) Enter waypoint number (001 to 199), in three digits.
- 3) Press the **ENT** key.
- 4) Press **▼**.
- 5) Enter a comment if desired.

By previously saved position

You can register a waypoint by using a previously saved position.

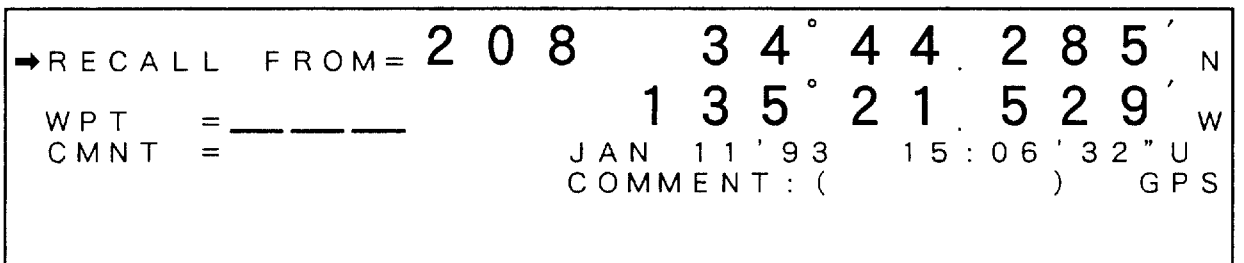

Figure 3-4 Typical RECALL FROM display

- 1) Press the **RCL** key several times to display the saved position you want to register as a waypoint.
- 2) Press **▼**.
- 3) Enter waypoint number (001 to 199).
CLR
- 4) Press the **ENT** key.
- 5) Press **▼**.

6) Enter comment if desired.

By range and bearing

You can enter a waypoint by using range and bearing from a previously entered waypoint, or a point of which latitude and longitude are known.

1) Press **MENU**, **3** and **2**.

R / B T O W A Y P O I N T					
→ FROM	WPT	=	---	(000~199)	
	LAT/LONG	=	0° 00 . 000'	N	0° 00 . 000' W
TO	WPT	=	---	(001~199)	
	LAT/LONG	:	0° 00 . 000'	N	0° 00 . 000' W
RANGE		=	0 . 0	NM	
BEARING		=	0 . 0	°	

Figure 3-5 R/B TO WAYPOINT display

2) Enter starting point.

① To use a previously entered waypoint as starting point;

CLR **ENT**

② To use latitude and longitude position as starting point;

▼

CLR ° . ' **(+/-)**^{*1}

*1: Press to change coordinate from North to South or vice versa.

CLR ° . ' **(+/-)**^{*2}

*2: Press to change coordinate from East to West or vice versa.

ENT

3) Press **▼**.

4) Enter waypoint number you want to register the waypoint under.

CLR **ENT**

5) Press **▼**.

6) Enter range from starting point to waypoint.

CLR **ENT**

7) Press .

8) Enter bearing from starting point to waypoint.

CLR **ENT**

NOTE 1: *You can not register an intermediate waypoint on a route.*

NOTE 2: *To register a radar target as a waypoint, use present position "000" as starting point.*

By LOP

You can register a waypoint by Loran time differences (TDs) or Decca phase differences. Firstly, change to Loran or Decca LOP display as prescribed in Chapter 5. The procedure for entering LOPs is almost the same as entering latitude and longitude.

1) Press the **WPT** key.

2) Press the **+/-** key when the display is on the latitude and longitude in order to changes to LOP display.

3) The remaining procedure is the same as that for entering latitude and longitude.

Displaying the waypoint list Press **MENU**, **3** and **0**. The waypoint list appears on the display.

WAYPOINT LIST		(+ / - : DATE)	
▲ 006 () :	34° 37 . 351' N	135° 08 . 380' W
007 () :	* 34° 40 . 350' N	135° 18 . 630' W
008 () :	34° 16 . 620' N	135° 59 . 020' W
009 () :	34° 09 . 550' N	134° 49 . 190' W
010 () :	* 33° 38 . 010' N	134° 28 . 790' W
▼ 011 () :	32° 01 . 00 ' N	135° 10 . 407' W

Figure 3-6 Sample WAYPOINT LIST, latitude/longitude page

NOTE: *Asterisk indicates write-protected waypoint.*

The **+/-** key functions to alternate display of the

latitude/longitude page and the date/time page.

WAYPOINT		LIST		(+ / - : L / L)		
▲	006 () : JAN	05 ' 93	23 : 45'	27" U	MNU
	007 () : JAN	02 ' 93	03 : 40'	00" U	MNU
	008 () : JAN	01 ' 93	08 : 35'	00" U	MNU
	009 () : JAN	12 ' 93	13 : 45'	00" U	MNU
	010 () : JAN	11 ' 93	20 : 00'	12" U	LC
▼	011 () : JAN	11 ' 93	22 : 14'	45" U	GPS

↑ DATE • TIME
↑ See below ↓

Figure 3-7 Sample WAYPOINT LIST, date/time page

Abbreviations used on the waypoint list

- MNU..... Entered manually by latitude and longitude.
- CLT..... Entered manually by range and bearing (latitude and longitude calculated).

For waypoints which are registered from saved or recalled position, the displays show the following:

- GPS GPS
- GDR Dead reckoning using speed and heading data
- DR Satellite navigator
- LC..... Loran C
- LA Loran A
- OM Omega
- DC Decca
- DGPS Differential GPS
- No navigator nor GPS. Also appears if position is fixed by GPS when DOP is inferior to DOP threshold.

You can scroll the waypoint list with ▲ and ▼.

Waypoint Navigation

The GP-500 MARK-2 can calculate best course between two waypoints or a waypoint and present position. In addition, it calculates the following:

- the range and bearing
- ideal course
- velocity to destination
- the estimated time of arrival
- the time-to-go to arrival
- cross track error, and
- course error.

Specifying present position as FROM waypoint

- 1) Press the **FR/TO** key. The display should look something like Figure 3-8.

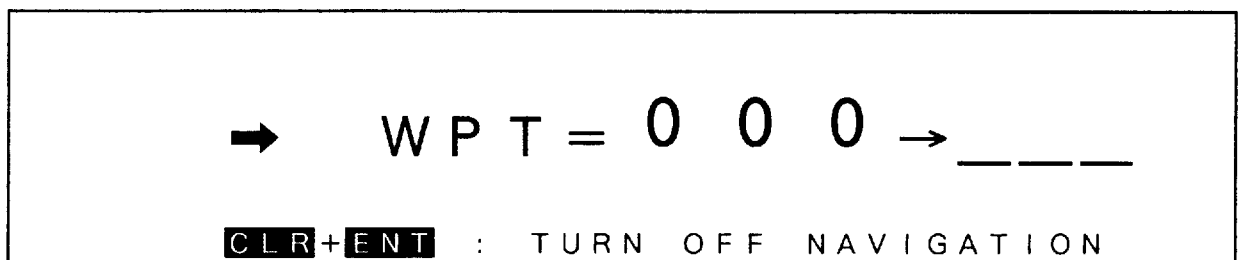

Figure 3-8 FR/TO display

- 2) Enter "TO" waypoint number (001 to 199), in three digits.
- 3) Press the **ENT** key.

The GP-500 MARK-2 automatically assigns present position as waypoint 000. Then, range and bearing from present position to the TO waypoint appear on the display.

Specifying registered waypoints as FROM and TO waypoints

1) Press the **FR/TO** key. The FR/TO display appears.

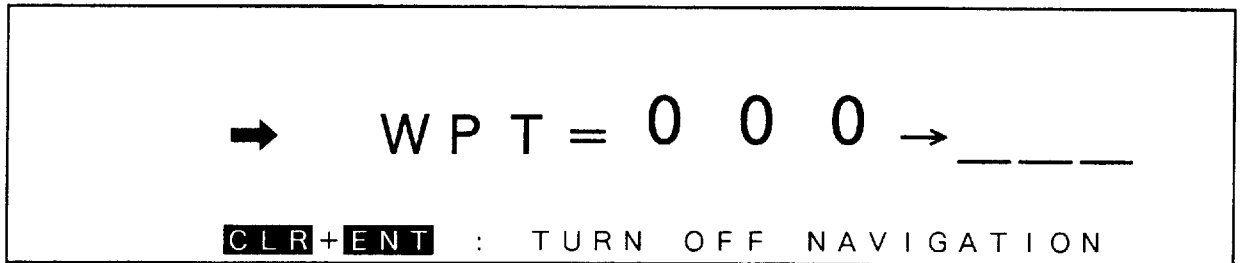

Figure 3-9 FR/TO display

2) Press the **CLR** key.

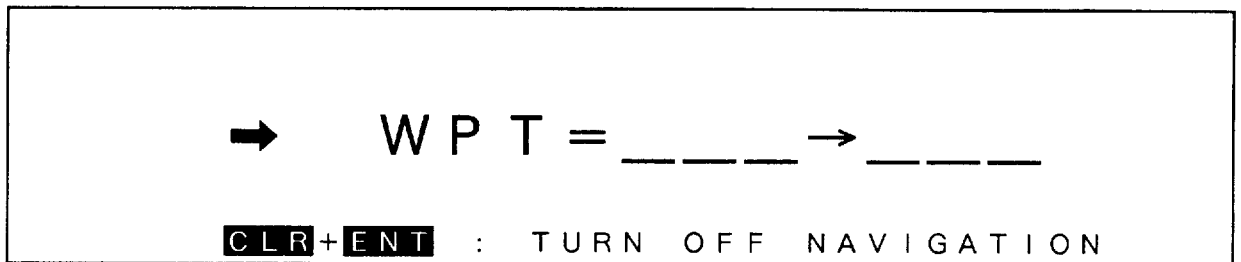

Figure 3-10 FR/TO display

3) Enter FROM waypoint number (001 to 199).

4) Enter TO waypoint number.

5) Press the **ENT** key. Then, range and bearing from the FROM waypoint to the TO waypoint appear on the display.

Canceling waypoint navigation

1) Press the **FR/TO** key.

2) Press the **CLR** key.

3) Press the **ENT** key. The range and bearing display appears, showing no information on the range and bearing lines.

Navigation and steering information The GP-500 MARK-2 displays various navigation and steering information when you select TO and FROM waypoints.

Cross track error

A straight line connecting the TO and FROM waypoints is called the track. It could just as well be called the intended track because although it is the navigator's intention to follow the track line, in reality, he never can do so perfectly because of wind, current, etc.

The amount your vessel is off track is called cross track error. You can display cross track error to the TO waypoint by pressing any of **SPD CRS**, **RNG BRG**, **XTE**, **TTG** or **SET DFT** keys.

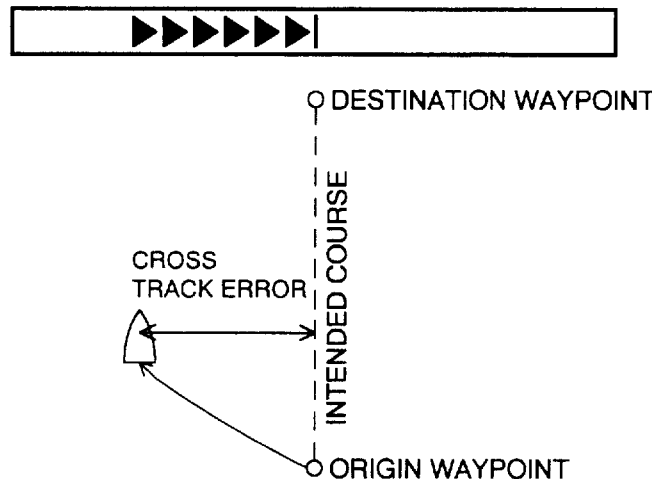

Figure 3-11 Cross track error display and graphic interpretation of cross track error

- The number of arrowheads changes with the amount of cross track error. One arrowhead is equal to 0.02 nautical miles of cross track error.
- To return your vessel to its intended track, steer in the direction and amount indicated by the arrowheads.

NOTE: *You can display course error instead of cross track error. Course error is the difference between the course and bearing. You will learn how to do this in Chapter 5.*

Speed, course and velocity to destination

Press the **SPD CRS** key. Each time you press the key one of the following displays appears.

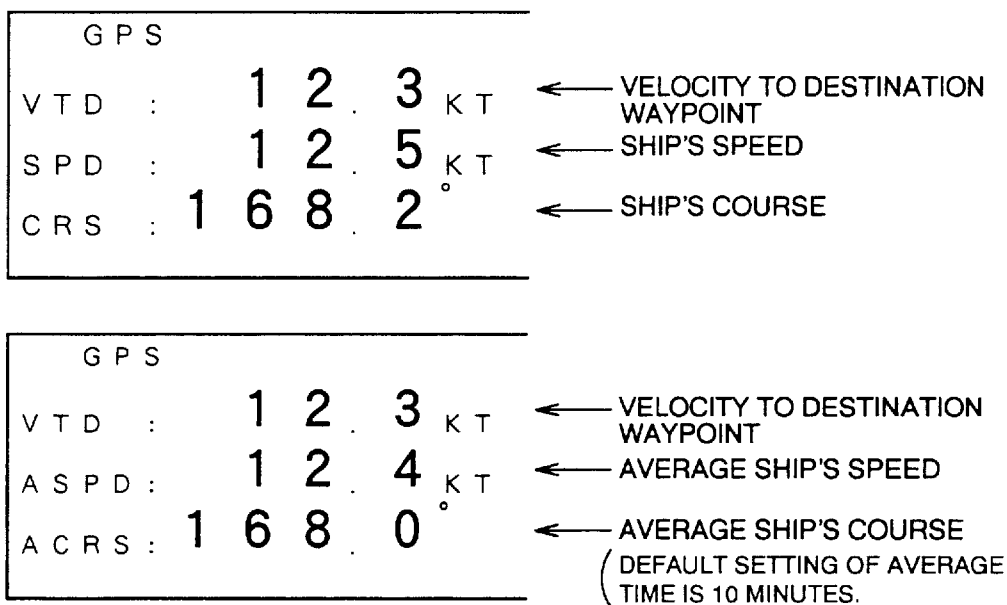

Figure 3-12 Typical speed and course display

When your vessel has deviated from its intended course (to the TO waypoint), there are two speed components: speed and velocity to destination.

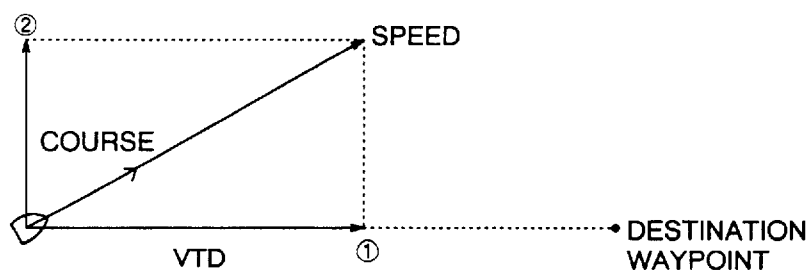

Figure 3-13 Graphic interpretation of velocity to destination

NOTE 1: When your vessel passes the TO waypoint a negative speed is displayed as VTD. You can display range or bearing to TO waypoint instead of VTD. (See page 5-5.)

NOTE 2: The speed and course are true ones. They differ from water-tracking speed and heading which are typically measured by a speed log and a gyrocompass, respectively. Take a look at Figure 3-14. The ship's heading is due North, but the ship's

direction has deviated to three degrees, due to water current. In this case the heading is 0 degrees and the course is 3 degrees.

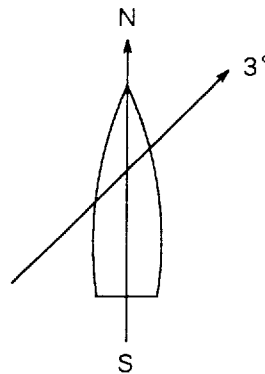

Figure 3-14 Heading and course

NOTE 3: When GPS position fixing is unavailable, the unit displays speed and course information taken from external navigator. If dead reckoning is selected, the speed and heading information are fed from a speed log and gyrocompass respectively, or manually entered through the keyboard.

NOTE 4: When your vessel is cruising at extremely low speed the course reading may change by as much as 180 degrees because of minute error in speed measurement. This is not an indication of equipment trouble.

NOTE 5: Speed and course readings can be “smoothed.” More on this in Chapter 5.

Range and bearing

Press the **RNG BRG** key.

GPS				
WPT :	0	1	4	← DESTINATION WAYPOINT
RNG :	1	2	5.7	← RANGE TO DESTINATION WAYPOINT
BRG :	1	6	8.2°	← BEARING TO DESTINATION WAYPOINT
			NM	

Figure 3-15 Typical range and bearing display, showing waypoint number and range and bearing from present position to waypoint

NOTE: *If you are navigating a route, the following display appears.*



Cross track error and course error

Press the **XTE** key.

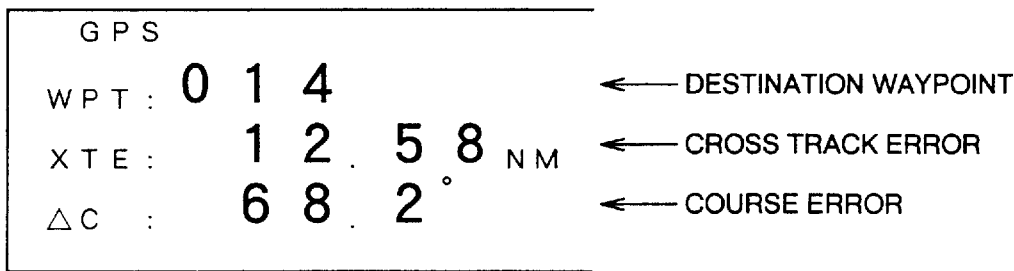

Figure 3-16 Typical XTE and course error display

A straight line connecting the FROM and TO waypoints is called the track. When your vessel is thrown off track by wind, etc., the amount in nautical miles the vessel is straying from its intended course is called the cross track error or XTE and the deviation angle is called course error. Course error is the difference between the course and bearing. You can display cross track error and course error by pressing the **SPD CRS** and **RNG BRG** keys, respectively.

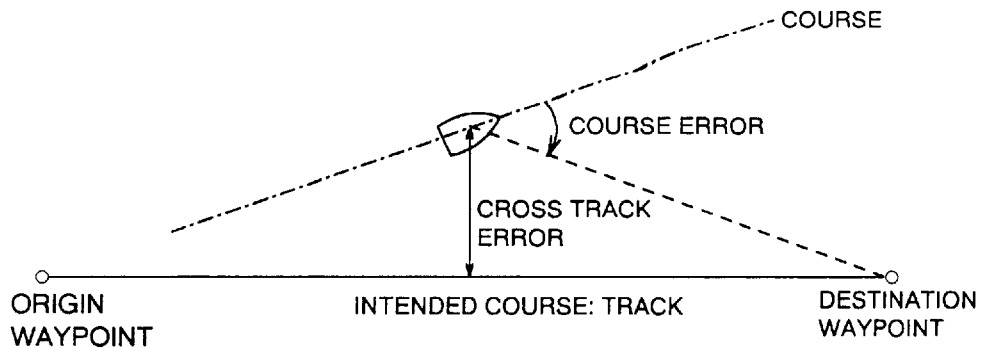

Figure 3-17 Graphic interpretation of course error and cross track error

Course error is also shown by bar graph. One arrowhead on the graph is equal to three degrees of course error.

Set and drift

Press the **SET DFT** key.

GPS		
LOG :	14.8 K T	← SHIP'S SPEED
GYRO :	72.5°	← HEADING
DFT :	2.5 K T	← CURRENT SPEED
SET :	68.2°	← CURRENT DIRECTION

Figure 3-18 Typical set and drift display

True velocity is measured during GPS position fixing. Relative velocity; that is, water tracking speed and heading, are fed from a speed log and gyrocompass, respectively. The drift and set are calculated as the difference between the true and relative velocities.

NOTE 1: *As a speed information, you can select speed log, manually entered speed, or NMEA 0183 data fed from an external navigator.*

NOTE 2: *Set and drift display is available only during GPS position fixing.*

NOTE 3: *Similar to course readings, set and drift readings may abruptly change when ship's speed is reduced. Chapter 5 explains how to smooth set and drift readings.*

Time-to-go

Press the **TTG** key.

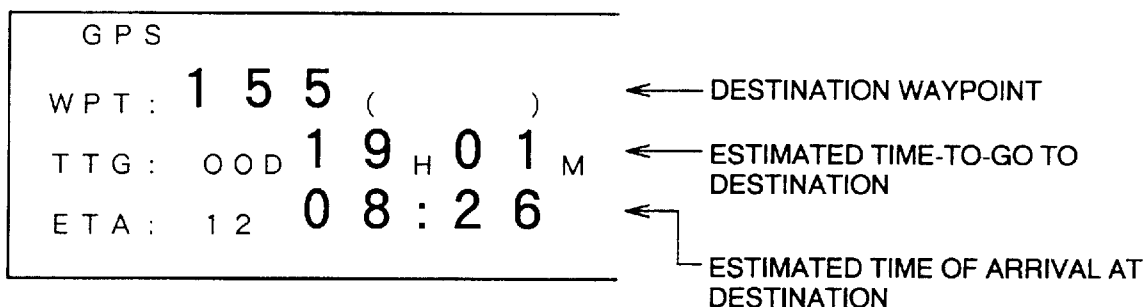

Figure 3-19 Typical TTG display

The TTG display shows the time remaining to reach the TO waypoint, maintaining current course and speed. Estimated time of arrival is also shown.

Displaying distance run

Press **MENU**, **6** and **1**. The distance run appears.

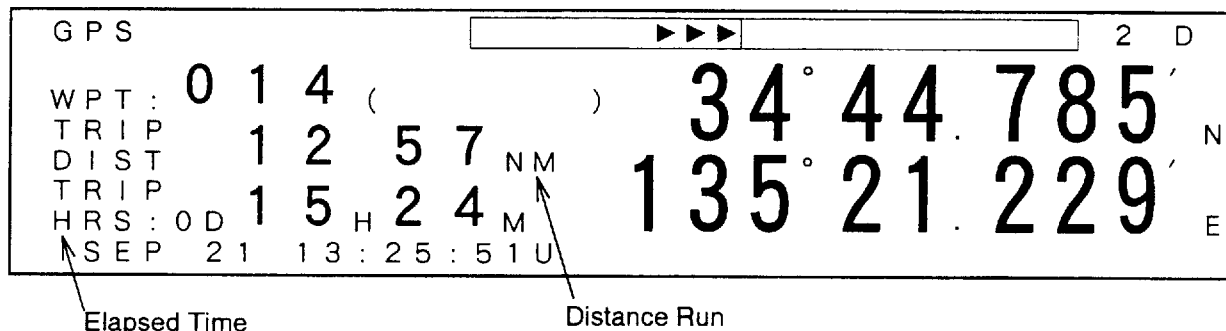

Figure 3-20 Distance run display

The distance run and elapsed time are reset to zero when you reset the TRIP RANGE to zero on the ALARM display. (See page 6-9.)

Calculating Range and Bearing Between Two Points

- 1) Press **MENU**, **3** and **1**. The CALCULATION display appears.

CALCULATION (1)					
→ FROM	WPT	=	--	(000 ~ 199)	
	LAT / LONG	=	0° 00 . 000	' N	0° 00 . 000 ' W
TO	WPT	=	--	(000 ~ 199)	
	LAT / LONG	=	0° 00 . 000	' N	0° 00 . 000 ' W

Figure 3-21 CALCULATION (1) display

- 2) Enter starting waypoint number (001 to 199).

Specifying registered waypoint as FROM waypoint

- (1) Enter waypoint number (001 to 199).

CLR

- (2) Press the **ENT** key.

- (3) Press **▼** twice.

Specifying latitude and longitude as FROM waypoint

- (1) Press **▼**.

(2) **CLR** ° . ' (**+/-**)

(3) ° . ' (**+/-**)

- (4) Press the **ENT** key.

- (5) Press **▼**.

- 3) Enter TO waypoint.

Specifying registered waypoint as TO waypoint.

(1) Enter waypoint number (001 to 199).

CLR

(2) Press **ENT**.

Specifying latitude and longitude as TO waypoint.

(1) Press **▼**.

(2) **CLR** ° . ' **(+/-)**

(3) ° . ' **(+/-)**

(4) Press the **ENT** key.

The range and bearing by great circle or rhumb line calculation appear on the display.

→ RESULTS	RHUMB LINE	:	232.9 NM	320.7°
	GREAT CIRCLE	:	232.1 NM	321.6°

Figure 3-22 Sample range and bearing calculation between two points

GREAT CIRCLE AND RHUMB LINE COURSES

The great circle course is the shortest path between two locations on the earth. It is usually used for long range navigation such as transoceanic voyages. To follow this course faithfully the helm must be steered continuously.

The rhumb line course is the pseudo shortest path between two locations on a chart. To follow a rhumb line course, the heading may be fixed if the distance is short.

You can select which course calculation method to use. More on this in a later chapter.

Calculating TTG and ETA Between Two Points

- 1) Press **MENU**, **3** and **3**. The CALCULATION display appears.

```

CALCULATION ( 2 )
→ FROM WPT = -- ( 000 ~ 199 )
      LAT / LONG = 0° 00 . 000' N 0° 00 . 000' W
TO WPT = -- ( 000 ~ 199 )
  LAT / LONG = 0° 00 . 000' N 0° 00 . 000' W
SPEED = 10 KT ( 001 ~ 999 )
  
```

Figure 3-23 CALCULATION (2) display

- 2) Enter starting waypoint number (001 to 199).

Specifying registered waypoint as FROM waypoint

- (1) Enter waypoint number (000 to 199).

CLR

- (2) Press the **ENT** key.

- (3) Press **▼** twice.

Specifying latitude and longitude as FROM waypoint

- (1) Press **▼**.

(2) **CLR** ° . ' **(+/-)**

(3) ° . ' **(+/-)**

- (4) Press the **ENT** key.

- (5) Press **▼**.

- 3) Enter TO waypoint.

Specifying registered waypoint as TO waypoint.

(1) Enter waypoint number (000 to 199).

CLR

(2) Press **ENT**.

Specifying latitude and longitude as TO waypoint.

(1) Press **▼**.

(2) **CLR** ° ' **(+/-)**

(3) ° ' **(+/-)**

(4) Press the **ENT** key.

4) Enter ship's speed for calculation (0 knot to 999 knot).

The TTG and ETA calculation appear on the display.

→ TTA/ETA : 00D18H32M/MAR 07 ` 93 14 : 48 U

Figure 3-24 Sample TTG and ETA calculation between two points

ROUTE NAVIGATION

In many cases a trip from one place to another involves several course changes, requiring a series of route points (waypoints) which you navigate to, one after another. The sequence of waypoints leading to the ultimate destination is called a route. The GP-500 MARK-2 can automatically advance to the next waypoint on a route, so you do not have to change the destination waypoint repeatedly.

NOTE: *The route planning function is a very useful and beneficial function to have available. However, the ability to switch waypoints automatically during a voyage can lead to some very dangerous situations. The use of any navigational aid requires constant exercise of common sense and caution. FURUNO Electric Company will assume no responsibility for any damages associated with use of the route navigation function.*

Creating a Route

You can store up to 10 routes. The unit numbers them 01 to 10. Each route may consist of up to 10 waypoints. Route number 00 is a special one. More on this later.

Be sure to record all important routes in a separate log. This unit is not a fail-safe record keeping device.

1) Press **MENU**, **5** and **0**. The ROUTE PLAN display appears.

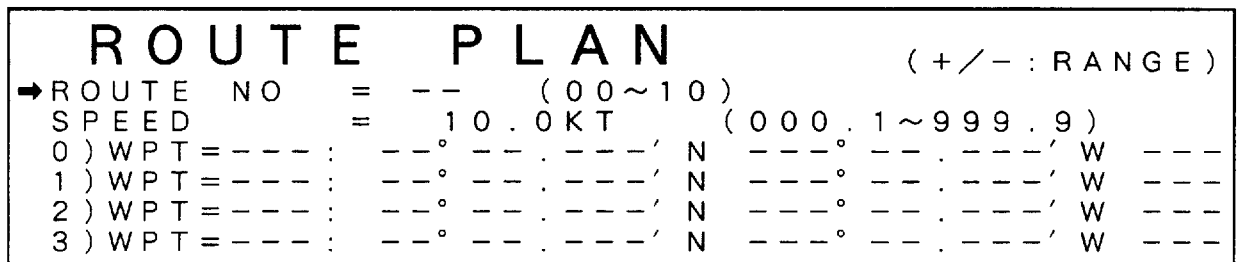

Figure 4-1 ROUTE PLAN display

2) Enter route number.

CLR **ENT**

NOTE: You cannot write over or delete a route which is currently used for route navigation.

3) Press **▼**.

4) Enter starting waypoint number.

CLR **ENT**

5) Press **▼**.

6) Repeat steps 4 and 5 to enter other waypoints for the route.

The **+/-** key functions to alternately display comments, range from FROM waypoint and ETA from FROM waypoint.

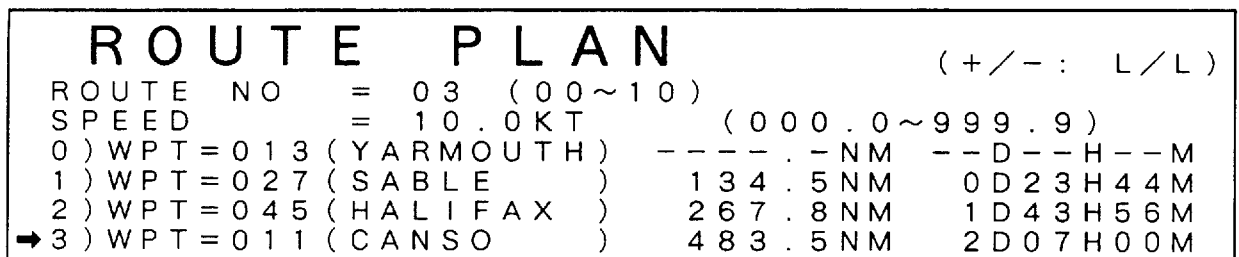

Deleting a Route and Route Contents

Deleting a route

1) Press **MENU**, **5** and **0**. The ROUTE PLAN display appears.

ROUTE PLAN		(+ / - : RANGE)			
ROUTE NO	= 03	(00 ~ 10)			
SPEED	= 10.0KT	(000.0 ~ 999.9)			
0) WPT=013 :	34° 26.320' N	135	13	950' W	MNU
1) WPT=027 :	34° 16.623' N	135	59	023' W	MNU
2) WPT=045 :	34° 07.950' N	134	49	260' W	MNU
→ 3) WPT=011 :	34° 04.451' N	134	36	328' W	*LC

Figure 4-2 ROUTE PLAN display

2) Enter the route number you want to delete.

CLR **ENT**

NOTE: You cannot delete or write over a route which is currently begin used for route navigation.

3) Press **CLR** and **ENT**.

Deleting route contents

1) Press **MENU**, **5** and **0**.

2) Enter route number.

CLR **ENT**

3) Press **▲** and **▼** to select waypoint you want to delete.

ROUTE PLAN		(+ / - : RANGE)			
ROUTE NO	= 03	(00 ~ 10)			
SPEED	= 10.0KT	(000.0 ~ 999.9)			
0) WPT=013 :	34° 26.320' N	135	13	950' W	MNU
→ 1) WPT=027 :	34° 16.623' N	135	59	023' W	MNU
2) WPT=045 :	34° 07.950' N	134	49	260' W	MNU
3) WPT=011 :	34° 04.451' N	134	36	328' W	*LC

Figure 4-3 ROUTE PLAN display

In Figure 4-3, waypoint 027 will be deleted from route number 3.

4) Press **CLR** and **ENT**.

The route is reorganized excluding the waypoint deleted. (The deleted line remains blank.)

Registering Route 00

The GP-500 MARK-2 provides a navigation calculator, called voyage plan, which determines the shortest distance between two points. You specify the starting, destination and number of intermediate points. Then, the GP-500 MARK-2 calculates the great circle among waypoints and generates intermediate waypoints on the route at equal distances. The thus generated route is route 00. This function is especially useful for long range navigation.

1) Press **MENU** and **4**. The VOYAGE PLAN display appears.

VOYAGE PLAN			
→ FROM WPT	=---		(0 0 1 ~ 1 9 9)
TO WPT	=---		(0 0 1 ~ 1 9 9)
NO OF WPT	= -		(1 ~ 9)
SPD FOR CALC	= - - . -	- K T	(0 0 . 1 ~ 9 9 . 9 K T)
ROUTE NUMBER	:	0 0	
RESULTS			

Figure 4-4 VOYAGE PLAN display

2) Enter starting waypoint number (001 to 199).

CLR **ENT**

3) Press **▼**.

4) Enter destination waypoint number (001 to 199).

CLR **ENT**

5) Press **▼**.

6) Enter number of intermediate waypoints, up to nine, in one digit from 1 to 9.

CLR **ENT**

7) Press **▼**.

8) Enter speed to use for calculation of time-to-go.

CLR **ENT**

To enter 10.5 knots, for example, press **1**, **0** and **5**.

9) Press . The cursor is on the RESULTS line.

10) Press . The display shows the results of the calculation.

```

VOYAGE PLAN (RESULTS)
WPT (FROM) : 012
LAT/LONG : 47° 00.000' N 100° 00.000' W
RNG/BRG : ---.---NM ---.---°
TTG : --D--H--M
TOTAL RNG/TIM : ---.---NM ---D--H--M
→RESULTS
    
```



Figure 4-5 VOYAGE PLAN display (results)

11) Press  to view automatically generated waypoints.

```



VOYAGE PLAN (RESULTS)
WPT (FROM) : P01
LAT/LONG : 48° 46.478' N 101° 23.145' W
RNG/BRG : 103.2NM 178.6°
TTG : 0D05H27M
TOTAL RNG/TIM : 103.2NM 0D05H27M
→RESULTS
    
```

Figure 4-6 VOYAGE PLAN display (results), showing automatically generated waypoint

- The unit numbers them from P1 to P9. Further pressing of  displays other automatically generated waypoints in forward order. Press the  key to display them in reverse order.

Modifying calculation results

If an island exists on route no. 00, for example, you can modify the latitude and longitude of a point to avoid the island.

- 1) Select the point you wish to change.
- 2) Press  and  to set the cursor on the LAT/LONG line.
- 3) **CLR** ° '
- 4) Press  to change latitude coordinate, if necessary.
- 5) ° '

- 6) Press **+/-** to change longitude coordinate, if necessary.
- 7) Press the **ENT** key.

Following a Route

This section shows you how to select and follow a route. Suppose that you have registered the route shown in Figure 4-7.

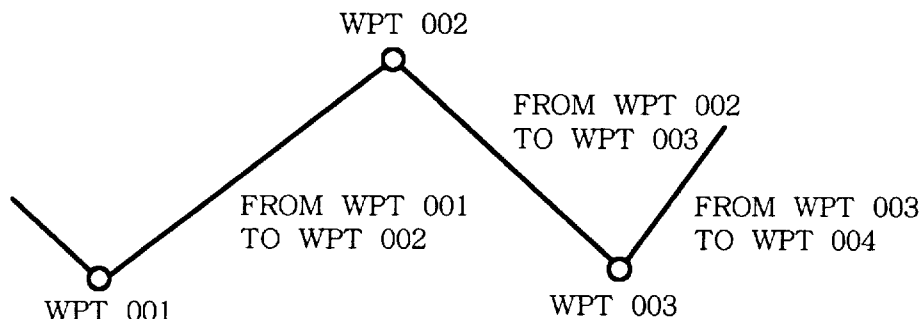

Figure 4-7 Sample route

When following a route you do not have to manually change the FROM and TO waypoints; the GP-500 MARK-2 changes them automatically upon arrival at a TO waypoint.

The unit switches waypoint when your vessel enters the alarm range set for the arrival alarm. The default setting is 0.5 nautical miles. You will learn how to change the arrival alarm range in Chapter 6.

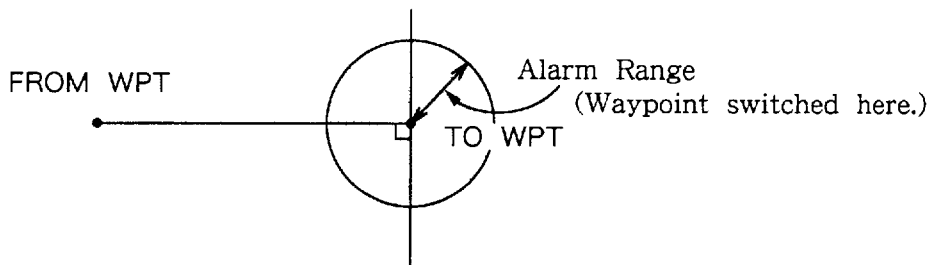

Figure 4-8 When the unit switches waypoints

Selecting a route

- 1) Press **MENU**, **5** and **1**. The ROUTE SELECT display appears.

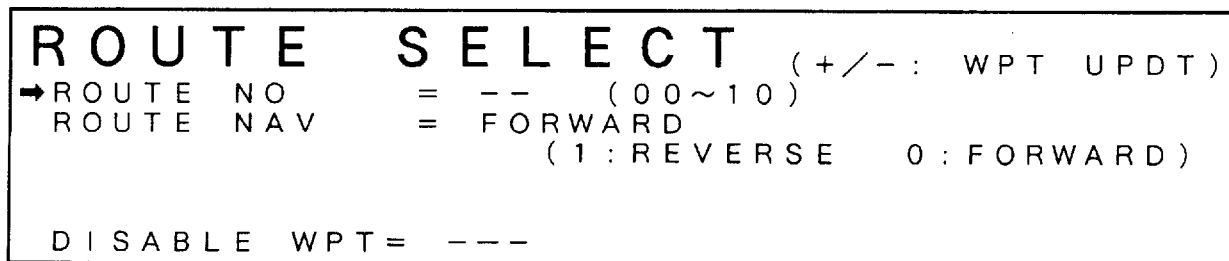

Figure 4-9 ROUTE SELECT display

2) Enter route number (00 to 10).

CLR **ENT**

3) Press .

4) Enter direction in which to traverse the route waypoints; forward or reverse. Enter 0 for forward; 1 for reverse.

If you want to omit specific waypoints;

5) Press .

6) **CLR** **ENT**

The unit recalculates the route excluding waypoint(s) disabled. It shows disabled waypoints in reverse video. If you want to enable the waypoint, enter its number as prescribed above.

```

ROUTE SELECT (+/- : WPT UPDT)
→ROUTE NO = 03 (00~10)
ROUTE NAV = FORWARD
              (1: REVERSE 0: FORWARD)
ROUTE 03 (000→005)
005→014→008→045→027→116→039→112→113→114
DISABLE WPT= ---

```

Figure 4-10 ROUTE SELECT display, showing disabled waypoint in reverse video

When you select a route;

Present position is registered as waypoint 000 and is the FROM waypoint. The initial TO waypoint is the first waypoint on the route.

Manual change of FROM and TO waypoints

As mentioned earlier, the FROM and TO waypoints are automatically changed when your vessel enters the arrival alarm zone. If the alarm zone range is set too tight, however, FROM and TO waypoints will not be changed. You can do it manually by displaying the ROUTE SELECT display and pressing the key.

In the display shown in Figure 4-10, for example, the present position is 000 and TO waypoint is 005. If you press the key, the FROM and TO waypoints change to 005 and 014.

NOTE: *Route navigation has priority over waypoint navigation.*

Connecting routes

A route may only consist of up to ten points. By combining routes, however, you can connect up to ten routes, maximum 100 points.

- 1) Press **MENU**, **5** and **2**. The ROUTE CONNECT display appears.

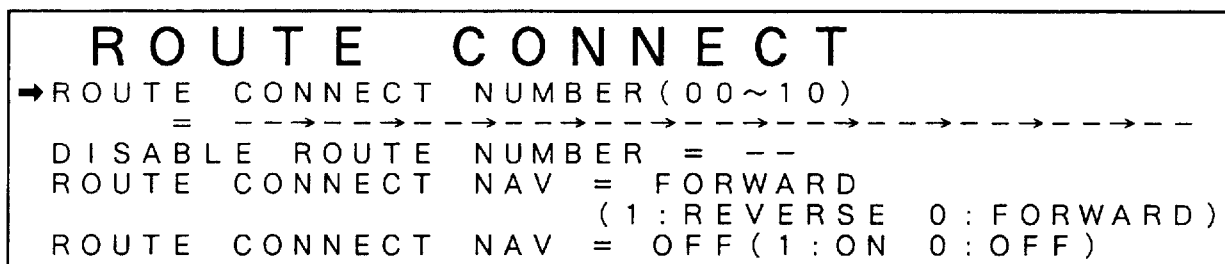

Figure 4-11 ROUTE CONNECT display

- 2) Press **CLR**.
- 3) Enter routes you want to connect, in navigating order.
- 4) Press **ENT**.
- 5) To disable a route;
 - (1) Press **▼**. The cursor moves to DISABLE ROUTE NUMBER.
 - (2) Enter route number you want to disable.

CLR **ENT**
- 6) Press **▼**.
- 7) Enter direction in which you want to traverse the route; forward or reverse.

CLR **ENT**

Enter 0 for forward; 1 for reverse.
- 8) Start navigation on connected routes.
 - (1) Press **▼**.

(2) Press **CLR** and **1**.

(3) Press **ENT**. "ON" appears on ROUTE CONNECT NAV line.

**Canceling
route
navigation**

1) Press **MENU**, **5** and **1**.

2) Press **CLR** and **ENT**.

This page intentionally left blank.

MISCELLANEOUS FUNCTIONS

This chapter covers miscellaneous functions. These are

- correcting chart system
- displaying magnetic bearing
- changing units of measurement and display indications
- selecting back-up navigator, and
- entering initial settings.

Selecting Geodetic Chart System

A nautical chart is usually made by either trigonometrical survey or astronomical survey and according to the geodetic chart standards of the country it is used in. For example, the USA uses the system called NAD-83; and Japan, TOKYO. Accordingly when you are getting position fixes by GPS in the USA, the system should be NAD-83 so you don't get a position fix which shows you're somewhere offshore when you're actually moored to a dock.

Standard GPS chart system

While the use of one category of chart systems is fine if you don't do transoceanic voyages, ocean-going vessels may require all categories to get reliable position information. To solve this inconvenience, a standard chart system was adopted by GPS: the WGS-84. The chart default setting is for WGS-84.

Chart systems stored in this unit

Although the WGS-84 system is now widely used other categories of charts still exist.

The GP-500 MARK-2 recognizes most major charts. (The charts this unit recognizes appear on page A-5 to A-8.) Select the chart system used, not the area where the boat is sailing.

Selecting chart system

1) Press **MENU**, **9** and **1**. The DATUM SELECT display appears.

```

  D A T U M   S E L E C T
  → DATUM SELECT      = WGS - 8 4
  VAR FROM WGS - 8 4   0 . 0 0 0 ' S   0 . 0 0 0 ' W

  0 0 1 : WGS - 8 4   0 0 2 : WGS - 7 2       0 0 3 : TOKYO
  0 0 4 : NAD - 2 7   0 0 5 : EUROPEAN        0 0 6 : AUSTRALIAN
  0 0 7 ~ : REFER TO OPERATOR ' S MANUAL
  
```

Figure 5-1 DATUM SELECT display

2) Enter geodetic chart number. The display shows the six major charts of the world. You may select one of these, or any of the charts shown on pages A-5 to A-8.

CLR **ENT**

NOTE: *The chart selected here affects GPS position fixes only. It does not affect latitude and longitude position fed from an external navigator.*

Entering Magnetic Variation

The location of the magnetic north pole is different from the geographical north pole. This causes a difference between the true and magnetic north direction. The difference is called magnetic variation, and varies with respect to the observation point on the earth. The GP-500 MARK-2 is preprogrammed with all the earth's magnetic variations. You can enter magnetic variation yourself, or let the GP-500 MARK-2 do it for you.

- 1) Press **MENU**, **9** and **4**. The MAGNETIC CORRECTION display appears.

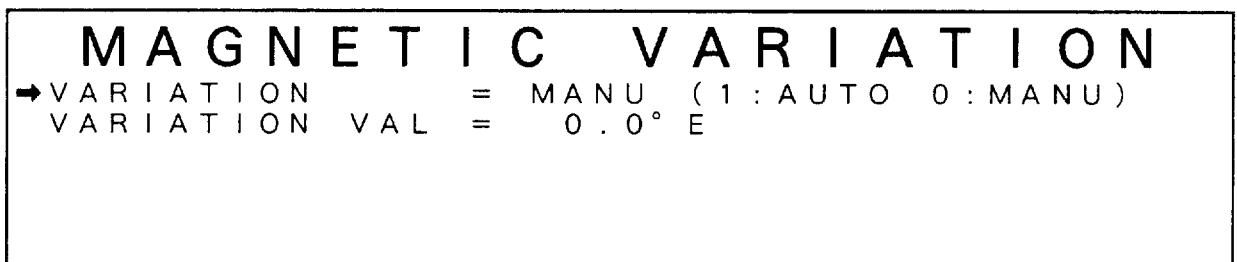

Figure 5-2 MAGNETIC VARIATION display

For automatic magnetic variation;

- 2) Press **CLR**, **1** and **ENT**.

The correction value is automatically calculated and displayed at the display bottom next to "MAG."

For manual magnetic variation;

- 1) Press **CLR**, **0** and **ENT**.
- 2) Press **▼**.
- 3) Enter magnetic variation, by consulting a recent nautical chart.

CLR **(+/-)** **ENT**

NOTE 1: If you have manually entered magnetic variation, be sure to change it when magnetic variation changes.

NOTE 2: To disable manual magnetic bearing display and return to true bearing, enter 000.0. (The indication "MAG" is erased.)

Changing Units of Measurement and Display Indications

- 1) Press **MENU**, **9** and **5**. The DISPLAY UNIT display appears.

D I S P L A Y U N I T			
→ LAT . LONG	RESO	=	0 . 0 0 1 (1 : 0 . 0 1 0 : 0 . 0 0 1)
RNG . BRG	CALC	=	GC (1 : RL 0 : GC)
HEIGHT	UNIT	=	METER (1 : METER 0 : FEET)
RNG • SPD	UNIT	=	NM (1 : NM 2 : KM 3 : SM)
BAR GRAPHIC		=	XTE (1 : OFF 2 : XTE 3 : ΔC)
VTD / BRG / RNG		=	VTD (1 : VTD 2 : BRG 3 : RNG)

Figure 5-3 DISPLAY UNIT display

- 2) Select resolution level for latitude and longitude display.

CLR **ENT**

Enter 1 for tenths place resolution; 0 for hundredths place resolution.

- 3) Press **▼**.

- 4) Select method for calculation of range and bearing; great circle or rhumb line.

CLR **ENT**

1 for rhumb line; 0 for great circle

- 5) Press **▼**.

- 6) Select unit for height.

CLR **ENT**

1 for meters; 0 for feet

- 7) Press **▼**.

- 8) Select unit for range and speed readouts.

CLR **ENT**

1, nautical mile; 2, kilometer; 3, statute miles

9) Press .

10) Select item to display on bar graph.

1, No display; 2, cross track error; 3, course error

11) Press .

12) Select item to display at top left-hand corner of the "SPD CRS" display. (See page 3-12.)

1, Velocity To Destination; 2, Bearing to TO waypoint; 3, Range to TO waypoint

Selecting Back-up Navigator

The GPS position fix is available almost 24 hours a day from January 1993. Thus the back-up navigator is rarely needed.

However, select the back-up navigator to use when there is no GPS position fixing available.

- 1) Press **MENU**, **9** and **3**.
- 2) Press **CLR**, **2** and **ENT**.

For no external navigator, select "2: GPDR."

```

BACK UP NAV SELECT
→BACK UP NAV          = GPDR
      ( 1 : NONE   2 : GPDR   3 : NNDR   4 : LRN-A
        5 : LRN-C  6 : OMG    7 : DEC    8 : I I NAV )
GPS POSN CORRECT     = NO    ( 1 : YES   0 : NO )
GPS COR SMOOTHING    = 0     ( 0 ~ 9 )
GPS CORRECT VAR      : 0.000' N 0.000' W
    
```

Figure 5-4 BACK UP NAV SELECT display

If there is no back-up navigator, enter speed and heading information as follows.

- 3) Press **MENU**, **9** and **2**.
- 4) Press **CLR**, **0** and **ENT** to select MANUAL (speed input).

```

LOG · GYRO DATA      (▼ : GYRO)
→LOG          = MANUAL  ( 1 : AUTO   0 : MANUAL )
SPD          = 0.0KT
LOG IN       = TTL     ( 1 : CONTACT 0 : TTL )
LOG PULSE ( IN ) =      200 P/NM ( 100 ~ 500 P/NM )
                                   ( 9000 ~ 30000 P/NM )
LOG PULSE ( OUT ) =      0 P/NM ( 0 ~ 500 P/NM )
    
```

Figure 5-5 LOG GYRO DATA display

- 5) Press **▼**.

6) Enter ship's speed, in three digits.

CLR **ENT**.

7) Press four times.

8) Press **CLR**, **0** and **ENT** to select MANUAL (heading input).

```
LOG • GYRO DATA (▲: LOG )
→GYRO = MANUAL (1: AUTO 0: MANUAL)
  HDG = 000.0°
SET/DFT SMOOTHING = 5 (0~9)
```

Figure 5-6 LOG GYRO DATA display

9) Press .

10) Enter heading.

CLR **ENT**.

NOTE: Steps 3 through 6 and 7 through 10 are for manual entry of speed and heading, respectively. For automatic entry, in case of speed log and gyrocompass connection, select AUTO on the LOG and GYRO lines of the LOG GYRO DATA display.

Initial Settings

The INIT DATA (2) display allows you to correct latitude and longitude position, enter smoothing values, and disable unhealthy satellites.

- 1) Press **MENU**, **9** and **0**. The INIT DATA (2) display appears.

I N I T D A T A (2)		(▼ : N E X T)	
→ L/L	CORRECTION	= 0.000' N	0.000' W
L/L	SMOOTHING	= 0 SEC	(00~99)
S/C	SMOOTHING	= 5 SEC	(00~99)
AVE	S/C SMOOTHING	= 10 MIN	(00~99)
DISABLED SATS :		-- -- -- -- -- -- -- --	
DISABLE SAT =		--	

Figure 5-7 INIT DATA (2) display (first page)

- 2) Enter latitude and longitude corrections.

CLR □.□□□' (+/ -)

□.□□□' (+/ -) **ENT**

You can correct the GPS-obtained position fix. Before entering a correction value here, however, confirm that the geodetic chart system setting agrees with your chart. (See page 5-2.). The correction value is applied to the GPS position fix only; it does not affect the position information fed from a back-up navigator.

- 3) Press **▼**.

- 4) Enter latitude and longitude smoothing.

CLR □ □ **ENT**

The GPS position fix changes randomly when the DOP or receiving condition is unfavorable. This fluctuation may be stabilized by smoothing the raw GPS position fixes as illustrated in Figure 5-8.

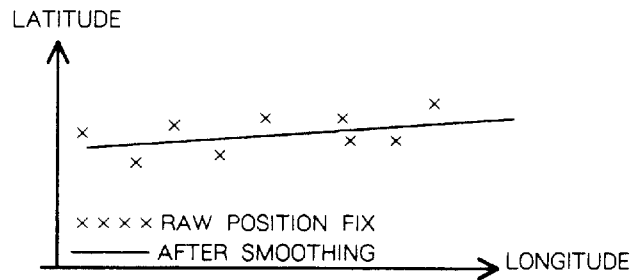

Figure 5-8 Latitude and longitude smoothing

The higher the setting the smoother the raw data. If the setting is too high, however, response to changes in latitude and longitude are delayed. The higher the number, the higher the smoothing. For no smoothing, enter 0. The normal smoothing setting is 0. Increase the setting when the GPS position fixes fluctuate intolerably.

5) Press .

6) Enter speed and course smoothing.

Ship's speed and course are directly measured when receiving GPS satellites. This raw data usually varies randomly depending on receiving condition and other factors. You can smooth this variation as illustrated in Figure 5-9.

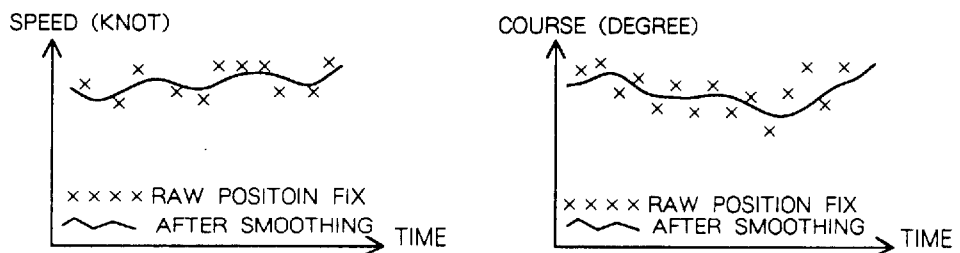

Figure 5-9 Speed and course smoothing

The higher the setting, the smoother the data. If the setting is too high, however, actual speed and course are not reflected on the speed and course readings, as illustrated in Figure 5-10. You can enter a smoothing rate from 00 to 99; 0 for no smoothing. "5" seconds is commonly used and provides excellent performance under most conditions.

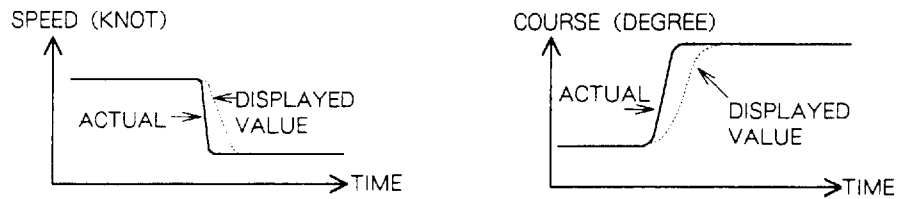

Figure 5-10 What happens when smoothing is set too high

7) Press .

8) Enter average speed and course smoothing.

The average speed and course are indicated at the SPD CRS display. The average speed and course smoothing setting affects calculation of time-to-go and estimated time of arrival. The default setting is 1 minutes and it provides excellent performance under most conditions.

9) Press .

10) You can manually disable unhealthy satellites to prevent use of them in GPS position fixing.

Every satellite broadcasts the abnormal satellites in its almanac. When the GP-500 MARK-2 receives an almanac, it automatically eliminates abnormal satellites from the GPS receiving schedule. When the satellite is once again "on-line," this unit includes it in the receiving schedule. Thus you normally are not required to manually disable an abnormal satellite.

Abnormal satellites appearing on the position fixing schedule are automatically deselected satellites. The disabled satellites shown on the INIT DATA (2) display are manually deselected satellites.

11) Press .

```

INIT DATA ( 2 )
SELECT = OFF ( 1 : LC  2 : LA  3 : DEC  4 : OFF ) (▼ : NEXT)

```

Figure 5-11 INIT DATA (2) display (second page)

12) You may input (and display) Loran A or C TDs or Decca LOPs.

CLR **ENT**

Select the position information you want to display. Enter 1, Loran C TDs; 2, Loran A TDs; 3, Decca LOPs; or 4, display latitude and longitude only.

13) Press .

● Loran C TDs

For your reference, Loran C chains appear on page A-9.

```

INIT DATA ( 2 )
SELECT = LC ( 1 : LC  2 : LA  3 : DEC  4 : OFF ) (▼ : NEXT)
→ GRI = 7980
LOP1 = 23 ( 11 , 23 , 43 , 59 )
LOP2 = 43 ( 11 , 23 , 43 , 59 )
L1 CORRECTION = 0.0us ( -99.9 ~ +99.9 )
L2 CORRECTION = 0.0us ( -99.9 ~ +99.9 )

```

Figure 5-12 INIT DATA (2) display

(1) Enter GRI.

CLR **ENT**

(2) Press .

(3) Enter slave code no. 1.

CLR **ENT**

(4) Press .

(5) Enter slave code no. 2.

CLR **ENT**

(6) Press .

● Loran A TDs

For your reference, Loran A chains appear on page A-10.

INIT DATA (2)		(▼: NEXT)
SELECT	= LA	(1 : LC 2 : LA 3 : DEC 4 : OFF)
→ LOP 1	= 1 L 5	(1 : S 2 : L 3 : H)
LOP 2	= 1 L 6	(1 : S 2 : L 3 : H)
L 1 CORRECTION	= 0 . 0 u s	(- 9 9 . 9 ~ + 9 9 . 9)
L 2 CORRECTION	= 0 . 0 u s	(- 9 9 . 9 ~ + 9 9 . 9)

Figure 5-13 INIT DATA (2) display

(1) Enter slave code no. 1.

CLR **ENT**

Use keys , and to enter S, L and H, respectively.

(2) Press .

(3) Enter slave code no. 2.

CLR **ENT**

(4) Press .

● Decca LOPs

Decca chains appear on page A-11.

```

INIT DATA ( 2 ) (▼:NEXT)
SELECT = DEC (1:LC 2:LA 3:DEC 4:OFF)
CHAIN NO = 24 (01~48)
→ LOP1 = GREEN (1:R 2:G 3:P)
LOP2 = PURPLE (1:R 2:G 3:P)
L1 CORRECTION = -0.00LANE (-9.99~+9.99)
L2 CORRECTION = -0.00LANE (-9.99~+9.99)

```

Figure 5-14 INIT DATA (2) display

(1) Enter chain number.

CLR ENT

(2) Press ▼.

(3) Enter slave code no. 1.

CLR ENT

Use keys and to enter red, green and purple stations, respectively.

(4) Press ▼.

(5) Enter slave code no. 2

(6) Press ▼.

Loran C

```

→ L1 CORRECTION = 0.0us (-99.9~+99.9)
L2 CORRECTION = 0.0us (-99.9~+99.9)

```

Loran A

```

→ L1 CORRECTION = 0.0us (-99.9~+99.9)
L2 CORRECTION = 0.0us (-99.9~+99.9)

```

Decca

```

→ L1 CORRECTION = 0.00LANE (-9.99~+9.99)
L2 CORRECTION = 0.00LANE (-9.99~+9.99)

```

14) Enter correction for LOP1.

CLR **(+/-)** **ENT**

Variation in signal propagation delay can cause constant errors in the computed LOP (or TD). You can enter manual LOP corrections to further refine the LOP coordinates on a particular chart.

15) Press .

16) Enter manual LOP or TD correction for LOP2.

CLR **(+/-)** **ENT**

17) Press .

INIT DATA (2)									
									(▼:NEXT)
BACKUP NAV	BUZZER	=	OFF	(1:ON	0:OFF)				
FORCED SAT	:	--	--	--	--	--	--	--	--
→ FORCED SAT	=	--							
1S CLK	CORRECTION	=	0	u s	(-999~+999)				

Figure 5-15 INIT DATA (2) (third page)

18) Select whether to generate the buzzer (three beeps) when GPS position fixing becomes available or unavailable. Enter 1 to enable the buzzer; 0 for no buzzer.

19) Press twice.

20) Enter clock correction in microseconds.

The GP-500 MARK-2 employs an extremely accurate clock which generates a one-second interval pulsed signal. It is synchronized to the GPS satellites atomic clock, but if the antenna cable is very long accurate synchronization may not be possible. In this case enter correction in microseconds.

Differential GPS

Refer to page 8-30 for DGPS Beacon Receiver and connect the cable to "Data in/out" connector. Initialize GP-500 Mark-2 according to the specification of the DGPS Beacon Receiver.

- Initial settings** 1) Press **MENU**, **8** and **0**. The INITIAL DATA (DGPS) display appears.

INITIAL DATA (DGPS) (▼:NEXT)			
→ D GPS MODE	= ON	(1: ON	0: OFF)
RTCM VERSION	= 2.1	(1: 1.0	0: 2.1)
BYTE FORMAT	= 8-6	(1: 8-8	0: 8-6)
FIRST BIT	= LSB	(1: LSB	0: MSB)
PARITY BIT	= NONE	(1: NONE	2: ODD 3: EVEN)
STOP BIT	= 1	(1: 2	0: 1)

Figure 5-16 INITIAL DATA (DGPS)

- 2) Press **CLR**, **1** and **ENT** to turn on DGPS function.

- 3) Press ▼.

- 4) Select RTCM VERSION.

CLR **ENT**

Enter for version 2.1.
(Only "version 2.1" is available.)

- 5) Press ▼.

- 6) Select BYTE FORMAT.

CLR **ENT**

Enter 1 for 8-6; 0 for 8-8.

- 7) Press ▼.

- 8) Select what comes for FIRST BIT.

CLR **ENT**

Enter 1 for LSB; 0 for MSB.

9) Press .

10) Select type of PARITY BIT.

Enter 0 for no parity bit.
(Only "no parity bit" is available.)

11) Press .

12) Select the number of STOP BIT.

Enter 0 for one stop bits.
(Only "one stop bit" is available.)

13) Press .

14) Select the number of BIT RATE.

Enter 0 for 8 bits.
(Only "8 bits" is available.)

15) Press .

16) Enter data communication speed (BAUD RATE) in four digits.

(Only "4800 bps" is available.)

When you are in a DGPS service area and in the DGPS mode, "DGPS" appears on the display. This means the position shown is corrected by DGPS.

When you go out of DGPS service area, "DGPS" disappears.

Data receiving status 1) Press **MENU**, **8** and **1**. The DGPS STATUS MONITOR display appears. This display shows the condition of the data reception.

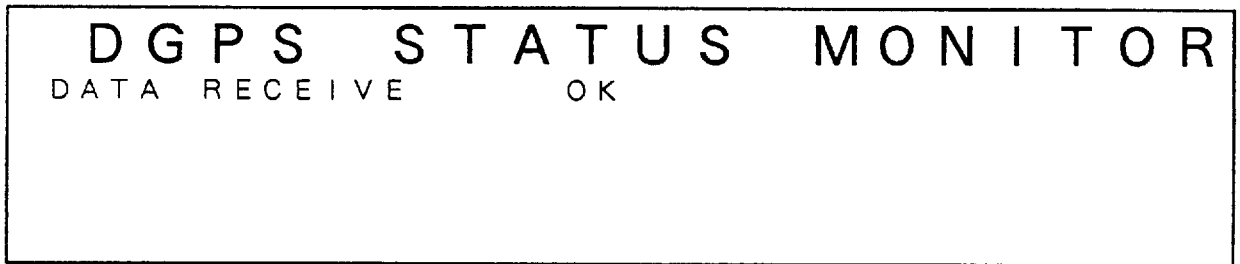

Figure 5-17 DGPS STATUS MONITOR

When the data reception is good, GP-500 MARK-2 starts DGPS operation.

“DGPS” appears as position-fixing system in use at the top left corner of the screen.

Default Settings

When the internal memory is cleared default settings are automatically restored. The default settings are as follows.

[MENU]

[0]: INITIAL DATA (1)

- Mon/Day/Year = */*/**
 - Time = *:*:*' **"
 - Local Zone Time = + 0 0H0 0M
 - Latitude = 38° 0 0.0 0' N
 - Longitude = 123° 0 0.0 0' W
 - Position Mode = 2 D
 - Antenna Height = 5 M
 - MASK ELEVATION = 5°
- } UTC is set.
- } San Francisco, USA

[9]: SYSTEM DATA MENU

[0]: INITIAL DATA (2)

- L/L Correction = 0.0 0 0' N 0.0 0 0' W
- L/L Smoothing = 0
- S/C Smoothing = 5
- AVE S/C Smoothing = 1
- DISABLED SATS = None
- SELECT = OFF
- Backup NAV Buzzer = OFF
- Forced Sats = None
- 1S CLK Correction = None

[1]: DATUM SELECT

- Datum Select = WGS-84

[2]: LOG•GYRO DATA

- Log Mode = MANUAL
- Speed = 0.0
- Log In = CONTACT
- Log Pulse (In) = 2 0 0 P/NM
- Log Pulse (Out) = 0 P/NM
- Gyro Mode = MANUAL
- Heading = 0.0
- Set/Drift Smoothing = 5

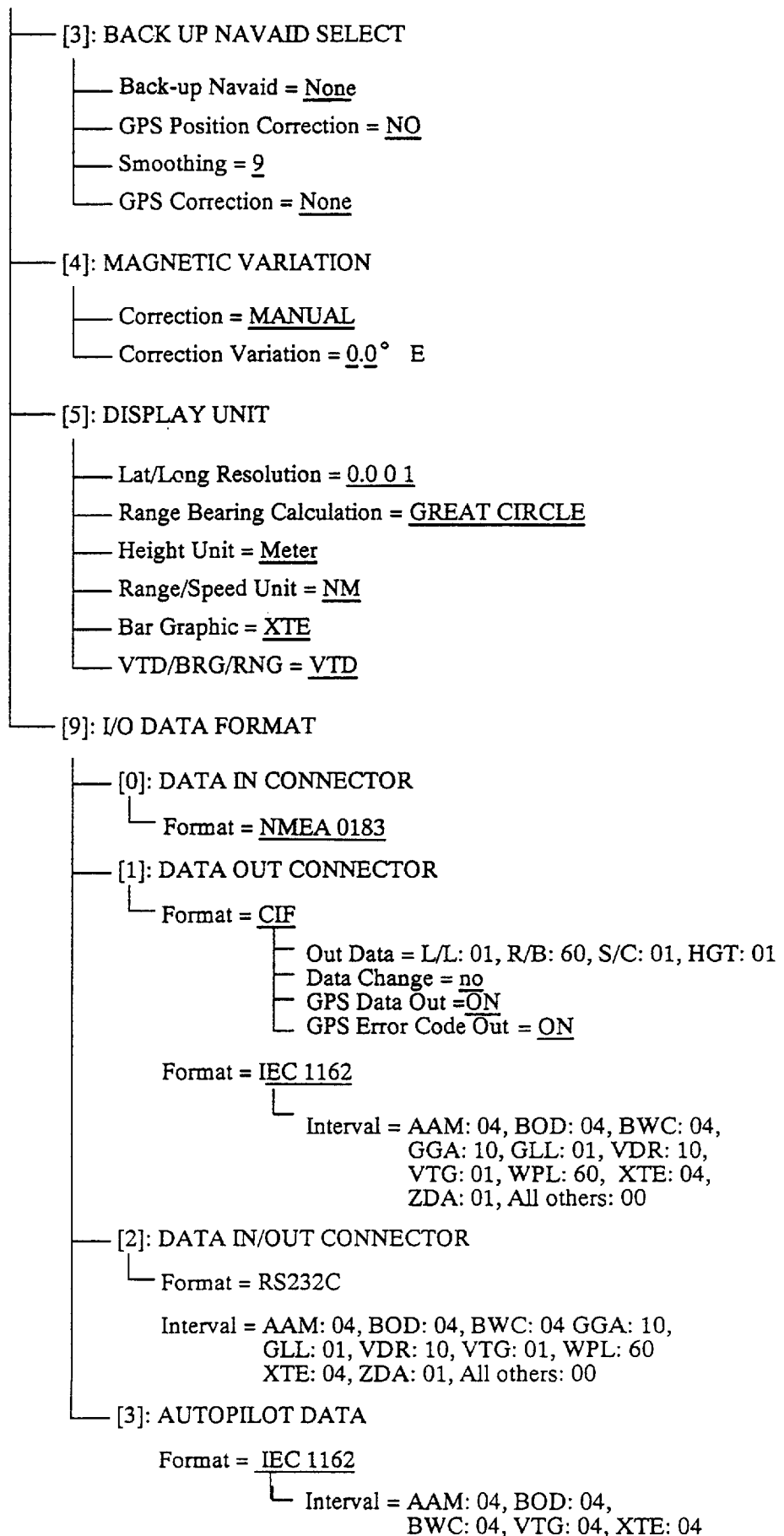

ALARMS

This chapter provides the information necessary for setting the alarms and the stopwatch. There are nine conditions which can generate both audible and visual alarms in the GP-500 MARK-2. These are:

- Timer
- Stopwatch
- Wake-up
- Arrival alarm
- Anchor watch alarm
- Cross track error (XTE) alarm
- Border alarm
- Ship's speed alarm, and
- Trip alarm.

CAUTION: *The alarms are useful for alerting you to possibly dangerous situations. However, the captain is always responsible for the safe operation of his ship. FURUNO Electric Company will assume no responsibility for any damages associated with the use of the alarms.*

Timer, Stopwatch and Wake-up

Description Timer

The audible alarm sounds when the preset time has elapsed.

Stopwatch

The stopwatch counts elapsed time.

Wake-up

The audible alarm sounds at the predetermined time.

Selecting timer or stopwatch

- 1) Press **MENU** and **2**. The TIMER SET display appears.

T I M E R		S E T	
→MODE SELECT	=	TIMER (1:TIMER 0:WATCH)	
HOUR	=	02H00M00S	
REPEAT	=	OFF (1:ON 0:OFF)	
BUZZER	=	ON (1:ON 0:OFF)	
WAKE UP TIME	=	06H25M	
BUZZER	=	ON (1:ON 0:OFF)	

Figure 6-1 TIMER SET display

- 2) Select timer or stopwatch. 1, timer; 0, stopwatch.

CLR **ENT**

- 3) Press **▼**.

If you selected the timer;

- (1) Enter the time interval you want to get the alarm.

CLR **ENT**
hr. min. sec.

- (2) Press **▼**.

- (3) Select 1 if you want repeated count down sequence with audible alarm at every terminal count. Select 0 for one-time count down.

(4) Press .

(5) Select if you want the audible alarm. 1 for yes; 0 for no.

(6) Press .

If you selected the stopwatch;

Note that the hour, repeat and buzzer indications do not appear with the stopwatch.

(1) Press .

4) Set wake-up timer.

(1) Set time desired.

hr. min.
 (00 to 23)

(2) Press .

(3) Press , and .

Select whether you want the audible alarm or not. 1, ON;
 2, OFF

Starting the stopwatch

1) Press and . The S.(top) WATCH display appears.

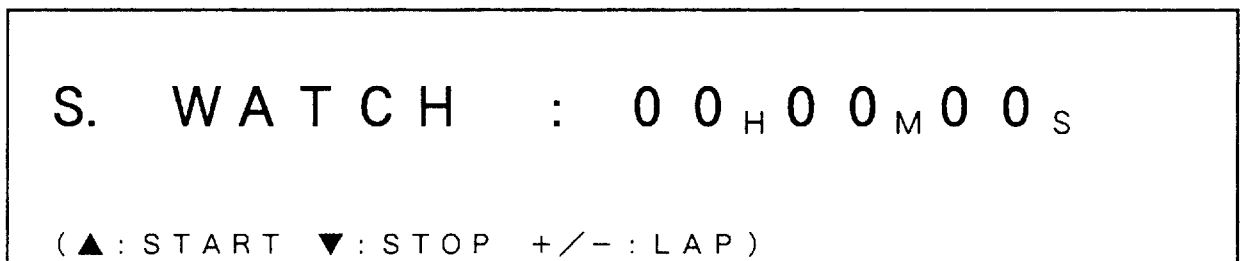

Figure 6-2 S. WATCH display

2) Press to start the stop watch.

3) If you need lap time, press . The reading freezes but the stopwatch continues to count up.

4) To return to stopwatch reading, press **+/-** again.

5) Press **▼** to stop the stopwatch.

NOTE: *The stopwatch counts up to 99 hours, 59 minutes and 59 seconds, whereupon it resets to zero and resumes counting up.*

Starting the timer

1) Press **MENU** and **1**. The TIMER display appears.

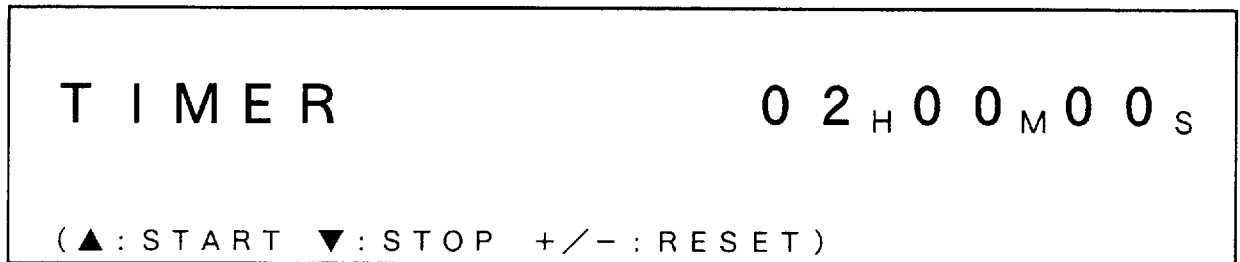

Figure 6-3 TIMER display

2) Press **▲** to start counting.

3) Press **▼** to stop counting.

4) Press **▲** to resume counting.

When the timer counts to 00 hours, 00 minutes, and 00 seconds, three beeps sound if REPEAT ON is selected, or the buzzer sounds continuously if REPEAT OFF is selected.

NOTE: *You can press **+/-** at any time to return to the preset time. Then, to restart the timer, press **▲**.*

Anchor Watch, Arrival, Cross Track Error, Border, Speed, & Trip Alarms

Alarm description

Anchor watch alarm

The anchor watch alarm sounds to warn you that your vessel has moved outside the anchor watch zone.

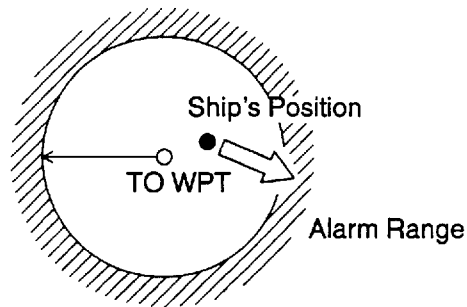

Figure 6-4 How the anchor watch alarm works

Arrival alarm

The arrival alarm warns you your vessel is approaching a destination waypoint. The area that defines an arrival zone is that of a circle which you approach from outside the circle. The alarm will be released if your vessel enters into the circle.

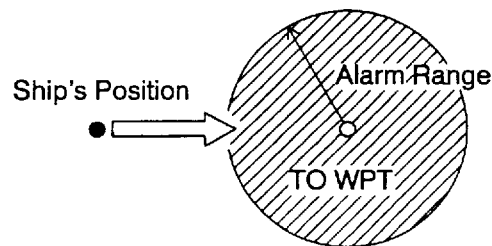

Figure 6-5 How the arrival alarm works

Cross track error alarm

The cross track error alarm alerts you when your vessel is off its intended course. You may preset the alarm limit from 0.01 nautical miles to a maximum lane width of 99.99 nautical miles. The alarm will be released if your vessel goes out of the lane limits.

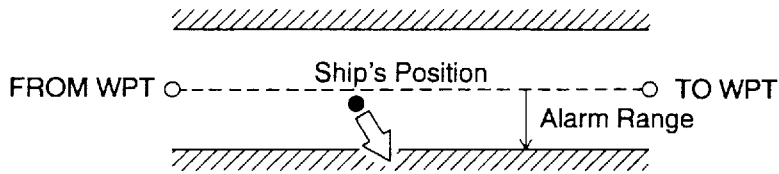

Figure 6-6 How the cross track error alarm works

Border alarm

The border alarm defines an area, comprised of two waypoints, starting waypoint and destination waypoint, which you do not want to cross. The alarm will sound when your vessel crosses the area defined by the two waypoints.

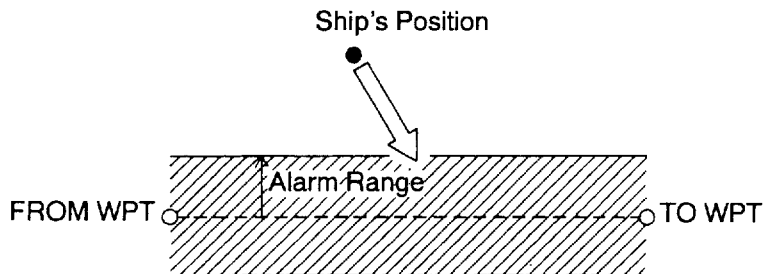

Figure 6-7 How the border alarm works

Ship's speed alarm

The ship's speed alarm sounds when ship's speed is higher or lower than the preset speed alarm setting.

Trip alarm

The trip alarm sounds when the trip distance exceeds the trip alarm setting.

How to set the alarms

- 1) Press **MENU**, **6** and **0**.
- 2) Set anchor watch alarm or arrival alarm.
 - (1) Enter alarm range and select alarm.

CLR **.** **□** **□** **(+/-)** **ENT**

Press **+/-** to select alarm desired; arrival or anchor watch.

```

A L A R M (▼: NEXT)
→ ARRIVAL = 1.25 NM (+/-: ANCHR/ARRIV)
   ACTIVATE = OFF (1: ON 0: OFF)
    
```

```

A L A R M (▼: NEXT)
→ ANCHOR WATCH = 1.25 NM (+/-: ANCHR/ARRIV)
   ACTIVATE = OFF (1: ON 0: OFF)
    
```

Figure 6-8 Displays for arrival and anchor watch alarms

(2) Press the **▼**.

(3) Turn the alarm on or off.

CLR **ENT**

1, ON; 0, OFF

(4) Press **▼**.

3) Set XTE (cross track error) alarm or border alarm.

(1) Enter alarm range and select alarm.

CLR **.** **.** **.** **(+/-)** **ENT**

Press **+/-** to select alarm desired; XTE or border.

```

→ XTE = 0.75 NM (+/-: XTE/BORDER)
   ACTIVATE = OFF (1: ON 0: OFF)
   ALARM BUZZER = ON (1: ON 0: OFF)
    
```

```

→ BORDER = 0.75 NM (+/-: XTE/BORDER)
   ACTIVATE = OFF (1: ON 0: OFF)
   ALARM BUZZER = ON (1: ON 0: OFF)
    
```

Figure 6-9 Displays for XTE and border alarms

(2) Press the **▼**.

(3) Turn the alarm on or off.

CLR **ENT**

1, ON; 2, OFF

(4) Press .

4) Select whether you want the audible alarm or not.

CLR **ENT**

1, ON; 2, OFF

If you have enabled the audible alarm it will sound when an alarm setting is exceeded.

5) Press .

ALARM			(▼ : NEXT)
→ MAX SPEED	=	999KT (000~999)	
MIN SPEED	=	0KT (000~999)	
MONITOR	=	OFF (1:ON 0:OFF)	
TRIP RANGE	=	0.0NM (0000.0~9999.9)	
MONITOR	=	OFF (1:ON 0:OFF)	
NAV ALARM BUZZER	=	ON (1:ON 0:OFF)	

Figure 6-10 ALARM display

6) Set ship's speed alarm.

(1) Enter maximum ship's speed.

CLR **ENT**

(2) Press .

(3) Enter minimum ship's speed.

CLR **ENT**

(4) Press .

(5) Turn the monitor (visual alarm) on or off.

CLR **ENT**

1, ON; 2, OFF

7) Set trip alarm.

(1) Enter alarm range.

CLR . **ENT**

To reset distance run to 0, enter 0000.0. (See page 3-16.)

(2) Press the .

(3) Turn the monitor (visual alarm) on or off.

CLR **ENT**

1, ON; 0, OFF

(4) Press .

8) Select whether you want the audible alarm or not. This is same as step 4). Enable or disable the audible alarm at step 4 or step 8.

When the audible alarm sounds, you can silence it by pressing the **CLR** key.

Alarm Display

When an alarm setting is exceeded or internal fault is detected the unit releases both audible (if enabled) and visual alarms. To know which alarm is sounding look at the alarm/error indication at the bottom right-hand corner of the display.

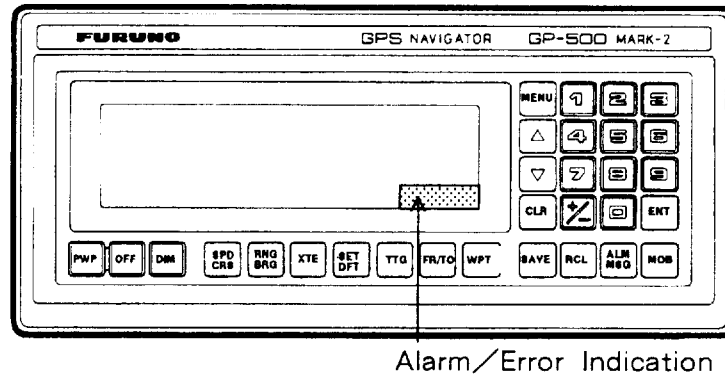

Figure 6-11 Location of alarm/error indication

The alarm/error indication appears on the speed/course, range/bearing, XTE, set/drift, and time-to-go display screens.

NOTE 1: "PF" appears on the display when turning on the power. This does not indicate equipment trouble. It will disappear when you press a key.

NOTE 2: You can silence the audible alarm with the **CLR** key. The visual alarm remains on the display until the cause of the alarm is removed.

NOTE 3: When two or more alarms are exceeded their indications appear alternately on the display.

Alarm indications

The following indications appear and blink every 2 seconds to alert you to alarm violation.

- HOUR Timer reached zero
- TIME Wake-up alarm
- ANCH Anchor watch alarm
- ARV Arrival alarm
- XTE Cross track error alarm
- BDR Border alarm
- SPD Ship's speed alarm
- TRIP Trip alarm

Error indications

The following indications appear and blink every 1.5 seconds to alert you to equipment error.

SERR: Self test error. The GP-500 MARK-2 tests itself periodically for proper operation. If it detects error, "SERR" appears. To identify the faulty component, conduct the self test described on page 7-6.

BERR: The memory contents are kept alive by a lithium battery when the power is off. The estimated life of the battery is four years. "BERR" appears when battery voltage is low. In this case you can set two dry cells (UM4) in the battery case on the rear panel, or replace the lithium battery. The life of the dry cell is about one year. You may leave the expired lithium battery inside the unit. (There is no fear of leakage for more than ten years.)

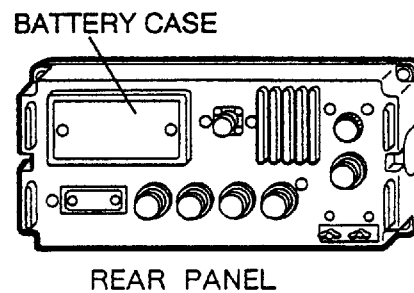

Figure 6-12 GP-500 MARK-2, rear view

NOTE 1: The dry cell batteries are not consumed while the power is on.

NOTE 2: Memory contents are preserved for about 12 hours with no back-up dry cells.

DERR: Data error. This means memory contents may have been corrupted by short circuit, noise, large fluctuation of supply voltage or other factors. Press the **ALM MSG** key. See page 6-15.

RERR: No data fed from back-up navigator for 30 seconds. Check navigator (gyrocompass, loran, etc.) and connection cable between GP-500 MARK-2 and navigator.

PF: Power failure. It appears momentarily when you turn on the power. If it appears any other time, check the ship's power supply.

D.ER: The condition of the DGPS data reception is no good.

Displaying Full Alarm/Error Indication

If several alarms or errors occur together, it may be difficult to distinguish which alarm is sounding, because alarm/error indications appear alternately. You can display on one screen which alarms are sounding.

Press the **ALM MSG** key. One of the following displays appears. The date and time when the alarm condition began appear on the display.

No alarm

```
NO ALARM  
  
JAN 15 '93 13:25 56 U
```

Alarm indications

Timer

```
ELAPSED HOUR ALARM  
  
SET TIME : 01H15M00S  
  
JAN 15 '93 13:25 56 U
```

Wake-up alarm

```
WAKE UP TIME ALARM  
  
WAKE UP TIME: 16H45M  
  
JAN 15 '93 13:25 56 U
```

Anchor watch alarm

ANCHOR WATCH ALARM

ALARM RANGE : 0.50NM

JAN 15 '93 13:25 56 U

Arrival alarm

ARRIVAL ALARM

ALARM RANGE : 2.50NM

JAN 15 '93 13:25 56 U

XTE alarm

OFF COURSE ALARM

ALARM RANGE : 2.50NM

JAN 15 '93 13:25 56 U

Border alarm

BORDER ALARM

ALARM RANGE : 2.50NM

JAN 15 '93 13:25 56 U

Trip alarm

TRIP ALARM
ALARM RANGE : 9999NM
JAN 15 '93 13:25 56 U

Ship's speed alarm

SPEED ALARM
MAX ALARM RANGE : 25KT
MIN ALARM RANGE : 5KT
JAN 15 '93 13:25 56 U

System alarm SERR

SELF TEST ERROR
JAN 15 '93 13:25 56 U

BERR

BATTER ERROR ALARM
JAN 15 '93 13:25 56 U

DERR

```

BACK UP DATA ERROR
CLEAR DATA?? (1: YES/OTHERE KEY:NO)

JAN 15 '93 13:25 56 U
    
```

- This message also appears when error is detected at the power-on self test.
- When this display appears clear the memory by pressing **1** and **ENT**. (If you want to record important waypoints in a log first press any key to escape from the error display. Go to the waypoint display and record waypoints into a log, and then press the **ALM MSG** key again.) All memories are cleared and default settings are restored.

RERR

```

RECEIVE ERROR

JAN 15 '93 13:25 56 U
    
```

D. ER

D G P S E R R O R A L A R M

J A N 1 5 ' 9 3 1 3 : 2 5 5 6 U



If several alarms or errors exist, "CONTINUE" appears at the bottom right-hand corner of the display. To display which alarms are sounding, press **ALM MSG** continuously.

A L A R M

C O N T I N U E

TROUBLESHOOTING

This chapter contains troubleshooting procedures. Whenever you suspect the unit is not functioning properly follow the troubleshooting procedure to try to restore normal operation.

 WARNING	
	<p>Do not open the cover of the equipment.</p> <p>This equipment uses high voltage electricity which can shock, burn or cause death. Only qualified personnel should work inside the equipment.</p>

Troubleshooting

Cannot receive satellite nor fix position

- (1) Check for disconnected antenna cable. Look for water leakage near the connector.
- (2) Position displayed is more than 10 degrees in error. If so, enter estimated position (within 10 degrees), referring to page 2-8.
- (3) Conduct the self test to identify faulty component, referring to page 7-6.
- (4) Display cold start information. (See page 7-11). If the almanac is more than one-year old, conduct the cold start.
- (5) Display satellite schedule information (page 7-5). If GPS satellite availability on your vessel is less than that on other GPS receiver-equipped vessels the almanac inside the GP-500 MARK-2 may be too old. Conduct the cold start to receive the almanac.

Position fixing period shorter than that on other vessels

- (1) Abnormal satellite selected as “healthy” satellite. See page 5-15.
- (2) Object (mast, etc.) within line of sight of GPS antenna. An object near the antenna may interfere with reception of the satellite signal.

Set, drift display error

Current speed and direction are calculated as the difference.

Set, drift display error

Current speed and direction are calculated as the difference between speed and speed log and course and gyrocompass, respectively.

- (1) Check speed log and gyrocompass for proper operation.
- (2) Check speed and course readings for accuracy. Speed and course will vary randomly by slow ship's speed, rolling, pitching, etc. (Ship's vibration is also measured as speed.) Thus current speed and direction will vary according to those factors.

Position error

Check for correction selection of geodetic chart.

Satellite Receiving Condition (SV Display)

Press **MENU**, **9** and **7**. The SV (Space Vehicle) CONDITION display appears. This display shows the condition of the satellites currently within line-of-sight.

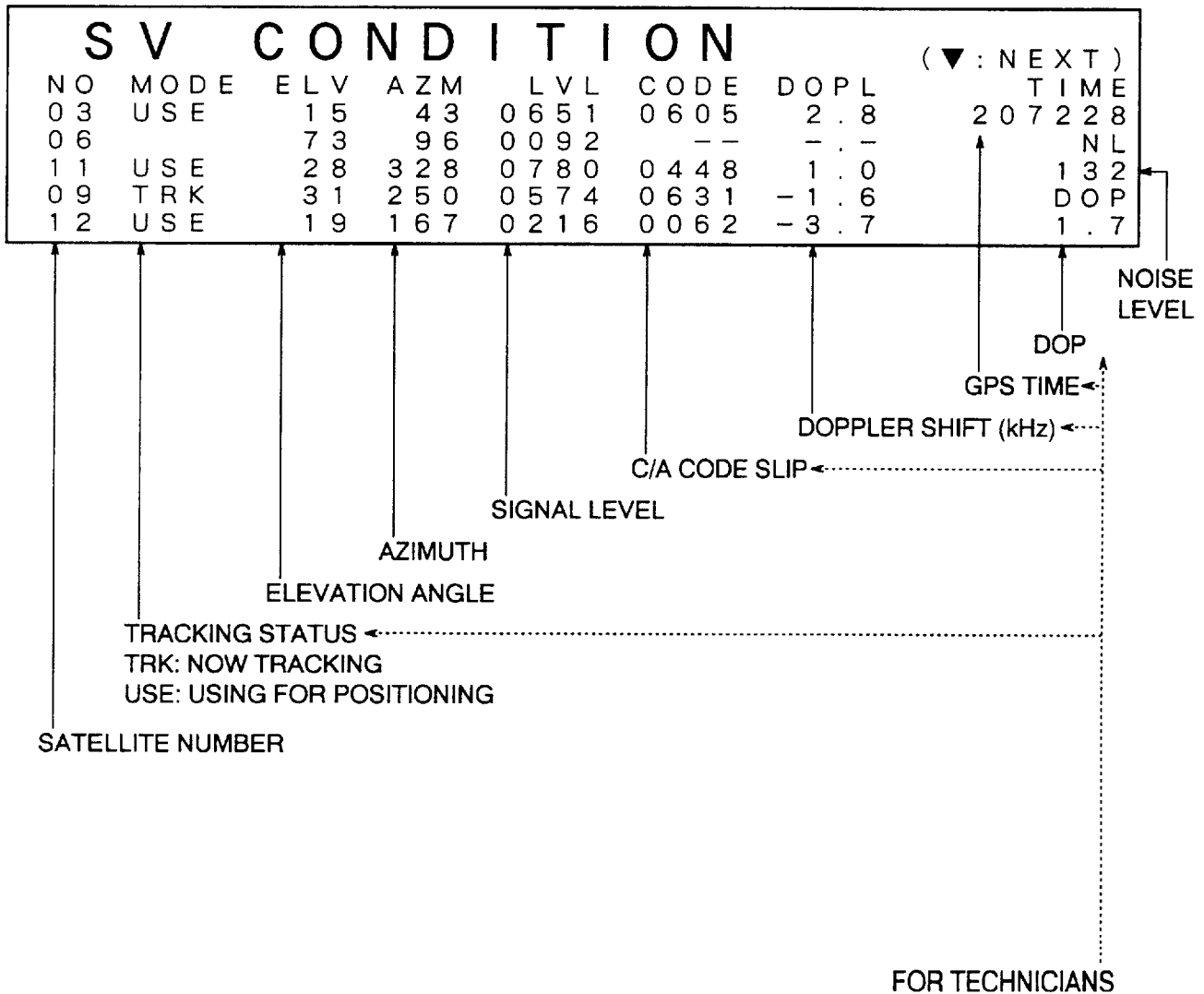

Figure 7-1 Typical SV CONDITION display

Future Satellites Display

Press **MENU** and **7**.

FUTURE SATELLITES										
1 .	JAN	15	-- : --	-->	09 : 34					
2 .	JAN	15	10 : 21	-->	16 : 56	DOP	:	3 . 7		
3 .	JAN	15	18 : 45	-->	22 : 01	NORMAL	:	8		
4 .	JAN	15	22 : 49	-->	02 : 04	ABNORMAL	SV			
5 .	JAN	16	02 : 37	-->	04 : 57	: 04	07	08	--	
6 .	JAN	16	05 : 12	-->	05 : 38	--	--	--	--	

FUTURE SATELLITES									
24 HOURS OK									

Figure 7-2 Typical FUTURE SATELLITES display

“--:--” means GPS position fix is available at present time. Current DOP also is shown.

NOTE 1: *Prediction based on almanac.*

NOTE 2: *Up to six periods within 24 hours are shown.*

NOTE 3: *The presentation is updated during GPS position fixing. If latitude and longitude are entered during period of no GPS position fixing the presentation is updated every three to four minutes.*

Testing the Unit for Proper Operation

The GP-500 MARK-2 contains various testing facilities which can be conducted by the user to check it for proper operation.

Self test

This function continuously tests the unit for proper operation. It is different from the power-on self test. While the test is being conducted GPS position fixing is not available.

- 1) Press **MENU**, **9**, **8** and **0**. Self test results appear on the SELF TEST display.

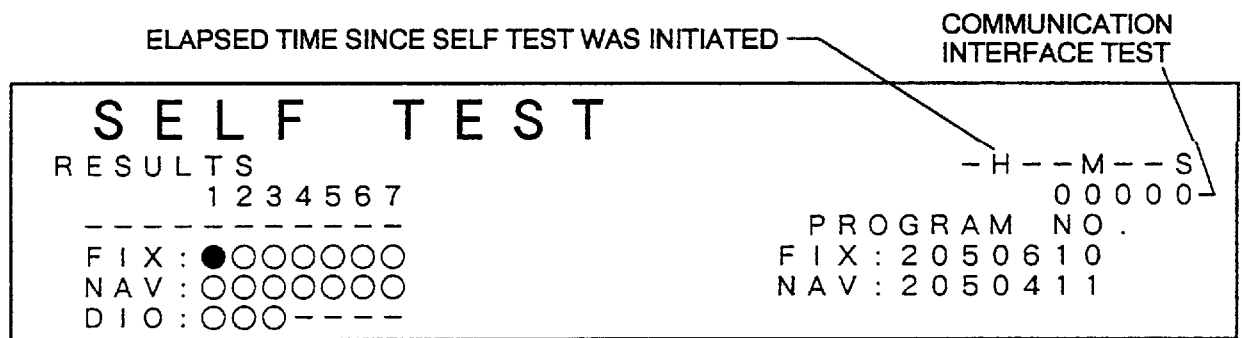
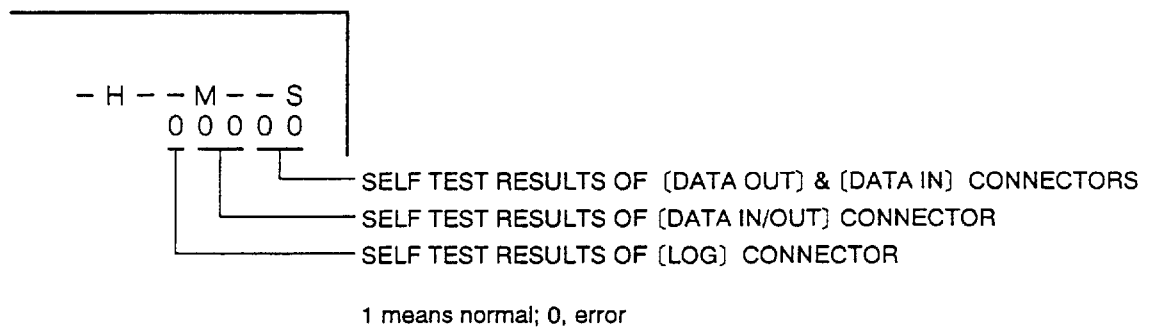

Figure 7-3 SELF TEST display

GPS (FIX), NAV and DIO Boards are tested. A filled circle (●) indicates board error. The test displays ROM program version numbers.

- 2) To escape from the self test, turn off the power by pressing **PWR** and **OFF** simultaneously.

Communication interface test



This test requires connection of Rx input with Tx inputs by jumper wires as shown in Figure 7-4. In this coupling the GP-500 MARK-2 transmits and receives a test data. If the received data matches the transmitted data, "1" appears on the display. If there is no jumper connected or if external equipment is connected "0" appears.

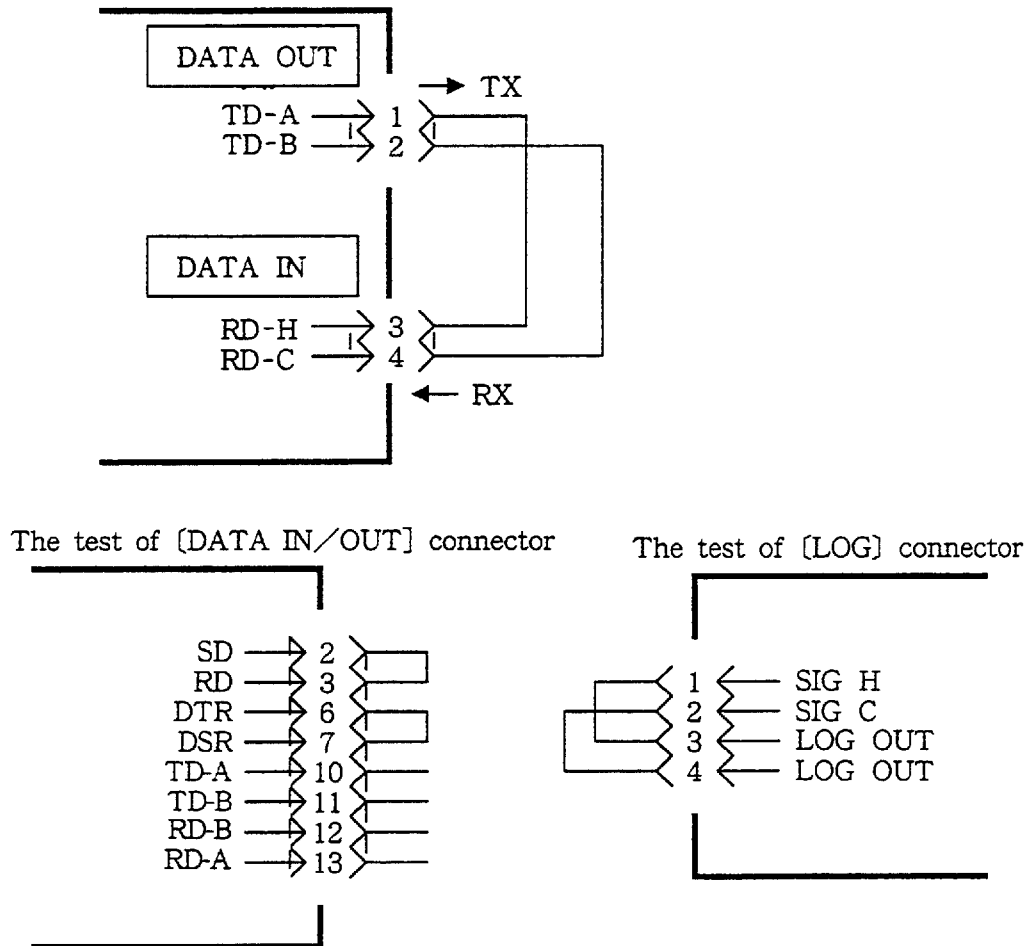

Figure 7-4 Jumper connection for communication test

Keyboard test This test checks each key for proper operation.

- 1) Press **MENU**, **9**, **8** and **1**.
- 2) Press each key one by one, except **PWR** and **OFF** keys. The associated indication fills the display if the key is functioning properly. Figure 7-5a shows key and associated indication.

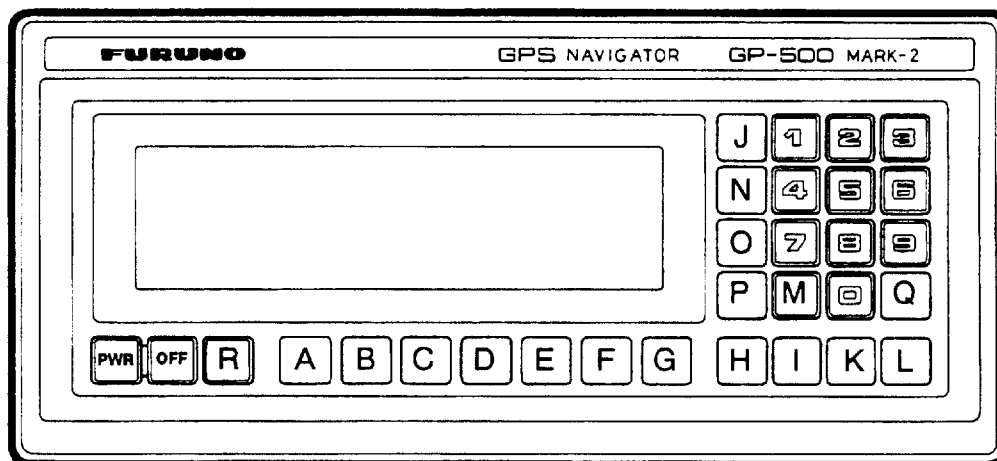

Figure 7-5a GP-500 MARK-2, showing key and associated indication in the keyboard test

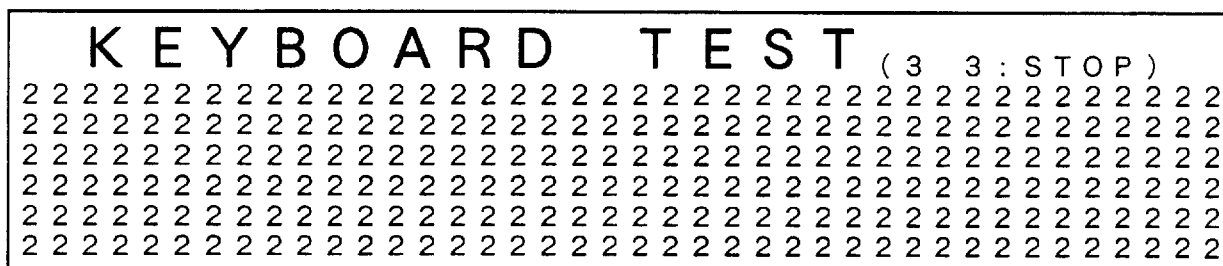

Figure 7-5b KEYBOARD TEST display, [2] key pressed

- 3) To escape from the test press the **3** key twice.

Clearing the Memory

You can clear all or specific memory banks. Clear all memories when the error indication “DERR” appears on the display, and clear specific memories when they contain errors.

Clearing all memories (including almanac)

- 1) Press **MENU**, **9**, **8** and **2**.
- 2) Press **▼**. The MEMORY CLEAR display appears.

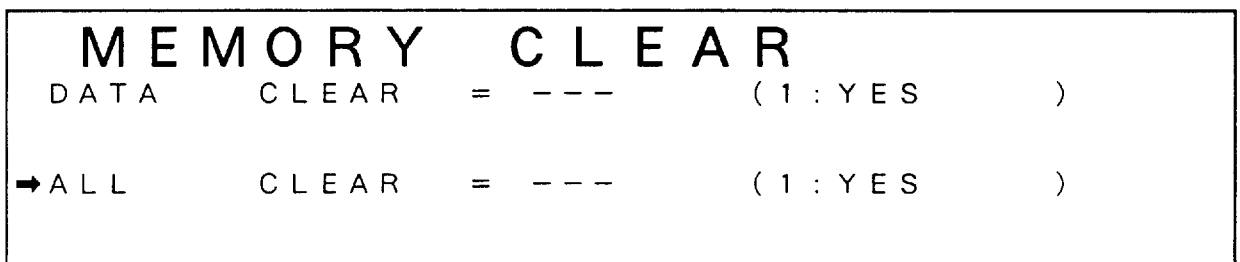

Figure 7-6 MEMORY CLEAR display

- 3) Press **CLR**, **1** and **ENT**. The unit starts clearing all memories.

When all memories are cleared, the screen is cleared, and then the MEMORY CLEAR display appears.

Receive the almanac to fix your position, as prescribed on page 7-11.

Clearing data memories

You can clear data memories when, for example, they contain error. Note that the waypoint memory and the almanac are not cleared. The following data are cleared:

```

INITIAL DATA (1) ..... (MENU, 0)
INITIAL DATA (2) ..... (MENU, 9, 0)
DATUM SELECT ..... (MENU, 9, 1)
LOG/GYRO DATA ..... (MENU, 9, 2)
BACK UP NAV SELECT ..... (MENU, 9, 3)
MAGNETIC CORRECTION .... (MENU, 9, 4)
DISPLAY UNIT ..... (MENU, 9, 5)
I/O DATA SELECT ..... (MENU, 9, 9)

```

- 1) Press **MENU**, **9**, **8** and **2**. The MEMORY CLEAR display appears.

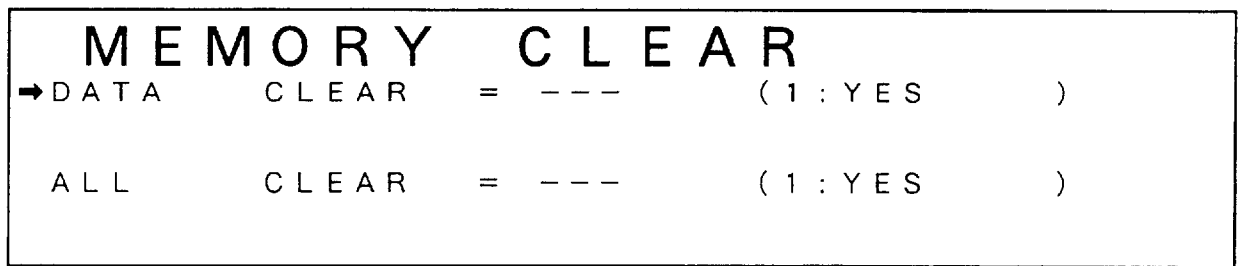

Figure 7-7 MEMORY CLEAR display

2) Press **CLR**, **1** and **ENT**.

When all data are cleared, the screen is cleared and then the MEMORY CLEAR display appears.

Cold Start

When the GP-500 MARK-2 has not been used for about 1 year or the memories have been cleared it takes considerable time to fix your position. (Note that extreme error in the present time or latitude and longitude position also cause this trouble.) This is because the existing almanac is too old to predict satellite arrival times. In this case conduct the cold start to receive the almanac and fix your position. It takes about 2 to 3 minutes to fix your position.

NOTE: *Estimated position should be within ten degrees. If it is more than ten degrees it may take more than 10 minutes to fix your position.*

- 1) Press **MENU**, **9** and **6**. The COLD START display appears. The display shows date and time existing almanac was received.

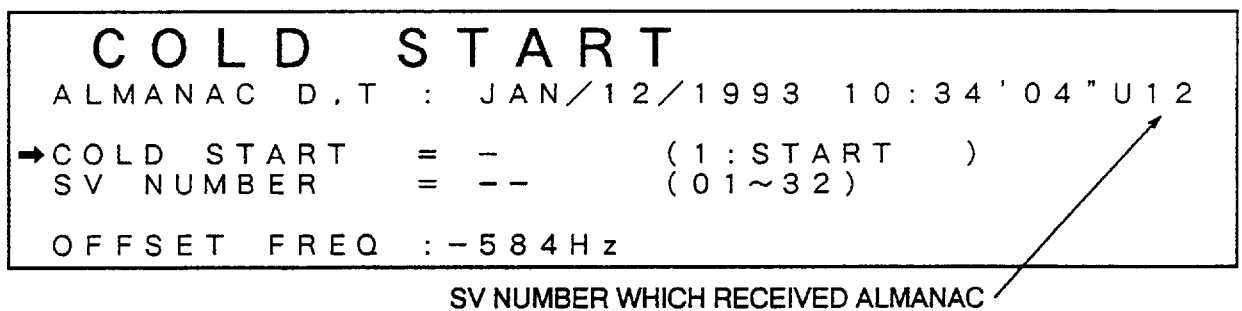

Figure 7-8 COLD START display

- 2) Press **CLR**, **1** and **ENT**. The existing almanac is cleared, indicated by erasing the information in "ALMANAC D, T," to acquire a satellite from which to receive the almanac.

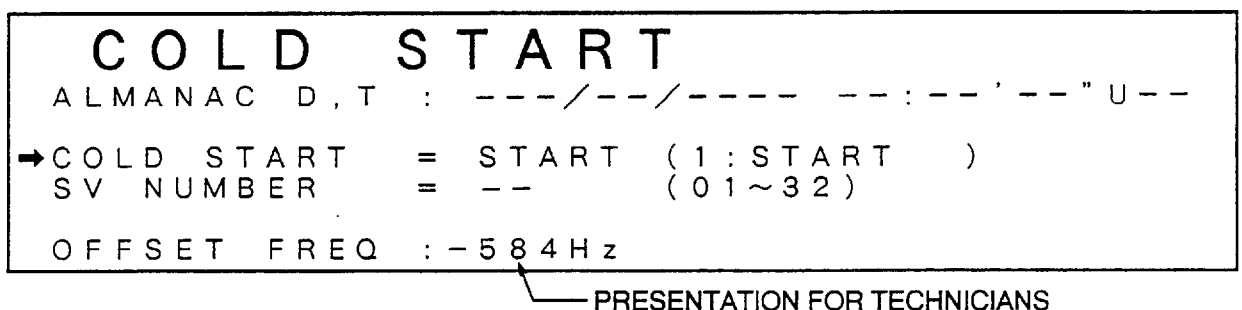

Figure 7-9 COLD START display, showing existing almanac is cleared

When almanac reception is completed, the date and time the almanac was received appears on the display.

INSTALLATION

Display Unit Installation

Mounting

Install the unit where the LCD can be easily viewed and the keyboard can be easily operated by referring to page D-2 or D-3.

The unit can be installed on the overhead, on a tabletop, or flush mounted in a panel. Be sure to leave a little slack in cables so the unit can be dismantled from the hanger with the connectors connected. This allows the service technician to work with a “live” set.

In addition to those points, observe the following precautions.

- Locate the unit out of direct sunlight because of heat which can build up inside the cabinet.
- The temperature and humidity of the mounting location should be stable and moderate.
- Locate the unit away from exhaust pipes and vents.
- The mounting location should be well ventilated.
- Mount the unit where shock and vibration are minimal.

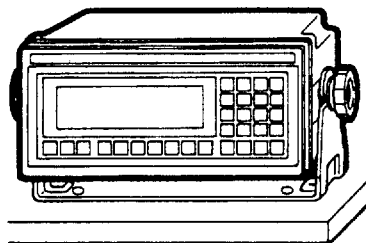

TABLETOP

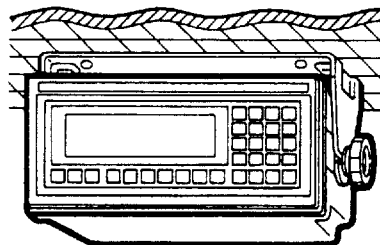

OVERHEAD

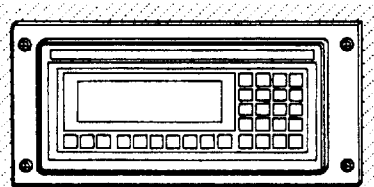

FLUSH MOUNT

Figure 8-1 Display unit mounting methods

Antenna Unit Installation

Mounting considerations When selecting a mounting location for the antenna unit keep in mind the following points.

- Install the unit outside of the radar beam. The radar beam will obstruct or prevent reception of the GPS satellite signal.
- Locate the unit well away from antennas of communication equipment. See the next page for minimum separation distances.
- Be sure the location offers a clean line-of-sight to satellites. Objects within line-of-sight to a satellite, for example, a mast or funnel, may prevent reception or result in long-lasting “Acquire” or “Interrupt” condition.
- Mount the unit as high as possible. Mounting the antenna as high as possible keeps it free of water spray, which can interrupt reception of a GPS satellite signal.

Antenna cable length The standard cable is 15m long. 30m length or 50m length cable is optionally available. This cable cannot be directly connected to the display unit since its diameter is too large. The basic procedure for attaching the cable to the antenna unit is as follows.

- 1) Cut the cable to appropriate length (if necessary).
- 2) Fabricate the end of antenna cable and attach the coaxial connector. Details are shown on next page.

◆ Waterproofing the connector

Wrap connector with vulcanizing tape and then vinyl tape. Bind the tape end with cable-tie.

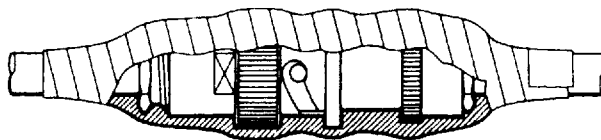

Figure 8-2 How to waterproof the antenna connector

How to attach the N-P-8DFB connector

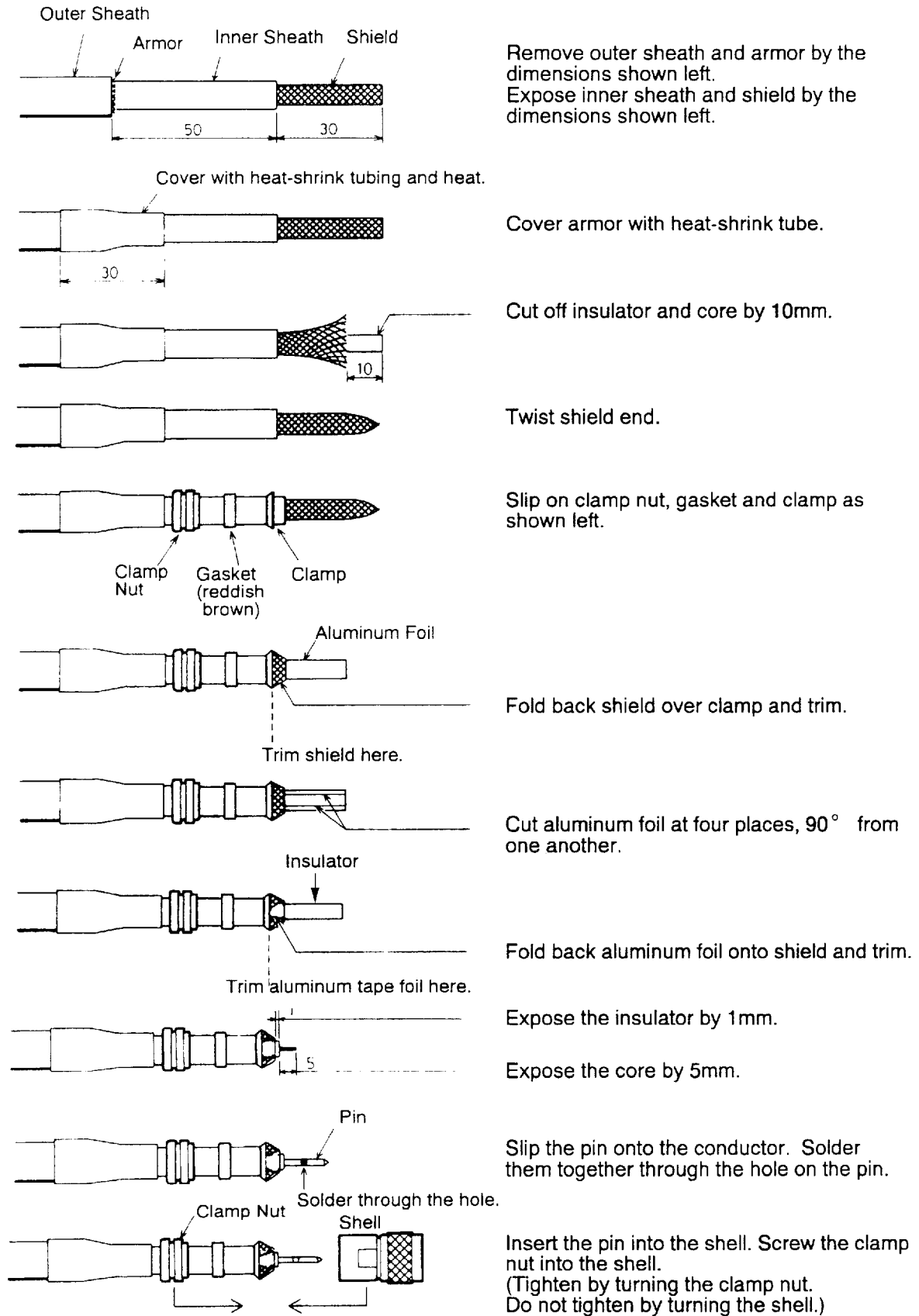

Figure 8-3 How to attach the N-P-8DFB connector

Table 8-2 Antenna cable and plug compatibility

Cable		Connection Diagram	Necessary Plug			Remarks
Max. Length	Type		Type	Code No.	Qty	
15m	3D-2V 3D-QEV 3D-XV	A	BNC-P117NI	000-112-144	2	
25m						
30m	RG-8/U	B	UG-21D/U	Local Supply	2	BNC-N Connector Conversion Adapter (000-123-810) Conversion Cable Assy. NJBP-3DXV-1 (000-117-602)
35m	8D-2V	B	N-P-8	000-501-512	2	
45m	5D-FB	B	N-P-5	000-107-861	2	
65m	8D-FB	B	N-P-8DFB	000-111-549	2	
83m	10D-FB	B	N-P-10	000-501-517	2	

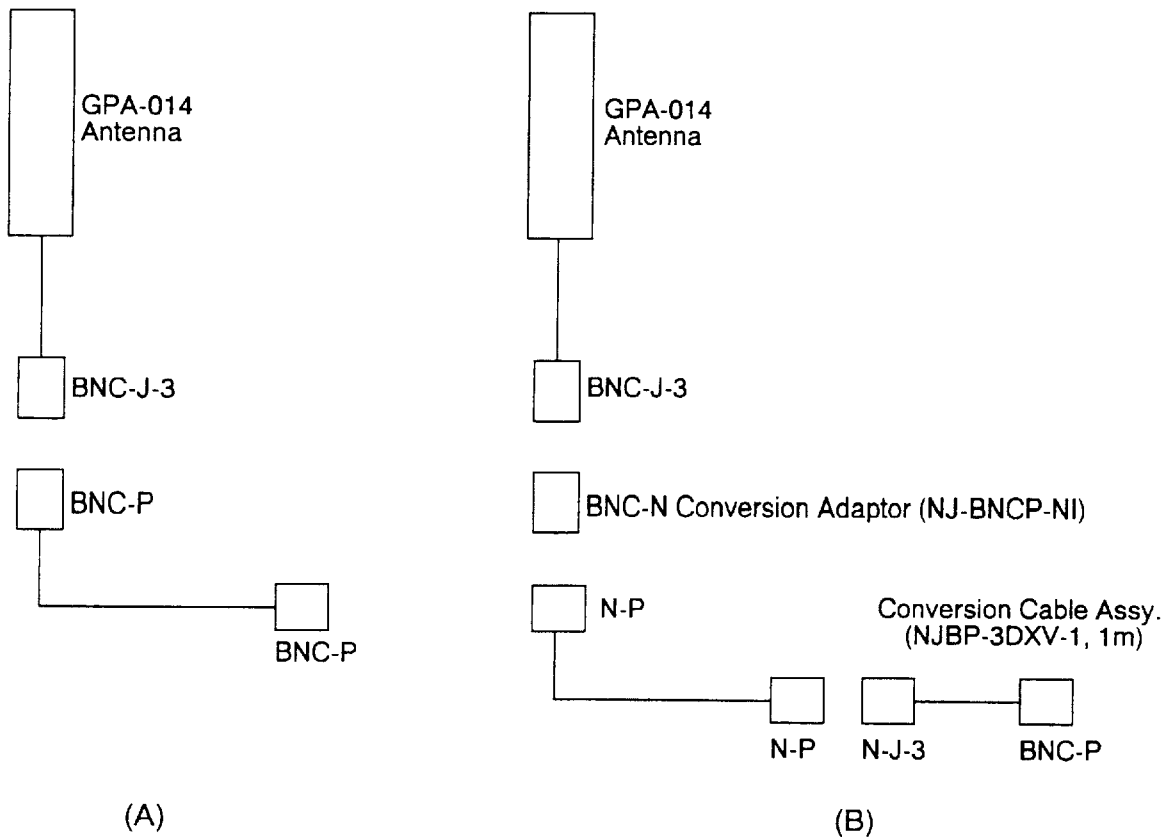

Figure 8-4 Adaptor plugs and connection method

Connections on the display Unit

Connect the antenna cable, the copper strap, the power cable and external equipment to the display unit as shown in Figure 8-5.

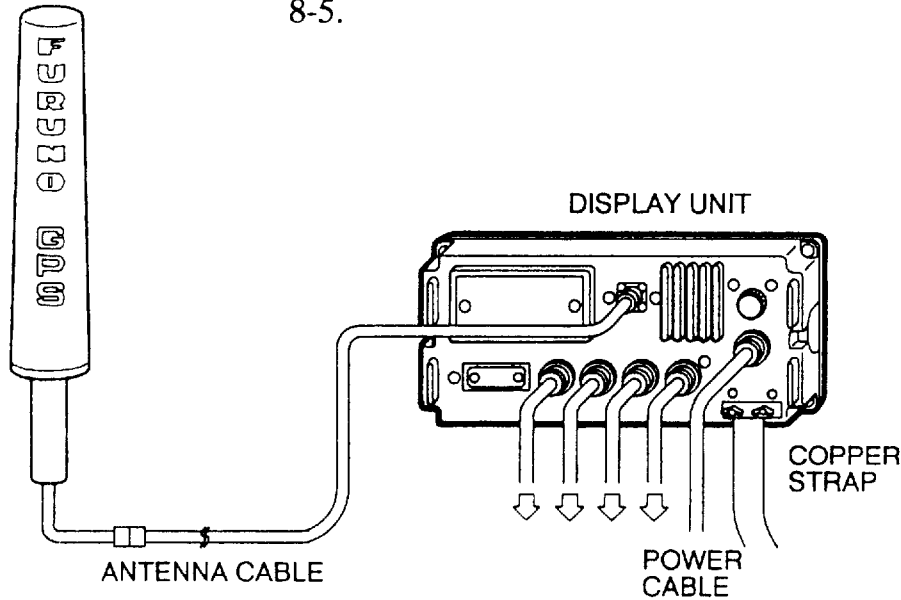

Figure 8-5 Connections

External equipment

The DATA OUT, DATA IN, GYRO, LOG, and DATA IN/OUT terminals either output position information to external equipment such as a radar, an echo sounder, a plotter, etc. or receive speed and heading data. A signal cable comes with the GP-500 MARK-2 for connection with external equipment. One end of the cable is prefitted with a connector. Connect it to appropriate connector. Attach a connector to the other end of the cable and connect it to external equipment.

Contact closure signal output representing ship's speed is available on **LOG** connector. This output is not the bypassed log signal input, but is generated by the GP-500 MARK-2 in accordance with the speed data which is obtained by GPS-reception or back-up navaid. Ratings of the relay contact are as follows.

	Resistance Load ($\cos \phi = 1$)	Inductance Load ($\cos \phi = 0.4, L/R = 7\text{ms}$)
Raring	125Vac 0.4A 30Vdc 2.0A	125Vac 0.2A 30Vdc 1.0A

An external buzzer may be connected. Contact closure signal is output, and you may connect a horn for a car, etc. The ratings for the relay contact are same as the one shown above.

Entering Initial Data

After installing the unit, enter initial data as follows.

Entering estimated latitude and longitude, antenna height

- 1) Press the **PWR** key.
- 2) Press **MENU** and **0**. The INIT DATA (1) display appears.

I N I T D A T A (1)		(▼:NEXT)
→ DATE	(M/D/Y) = 12/01/1992	
TIME	= 13:25'00" U	
LOCAL ZONE TIME	= +00H00M	
LAT	= 38° 00.00' N	
LONG	= 123° 00.00' W	
POSITION MODE	= 2D (1:2D 2:2D3D)	

Figure 8-6 INIT DATA (1) display

- 3) Press **▼** three times. Entry of date and time is not required. They are corrected when the unit receives a GPS satellite. To use local time instead of UTC, enter time difference on second line.
- 4) Enter estimated latitude within 10 degrees of actual position. Use the **+/-** key to switch coordinate from North to South and vice versa.

CLR ° ' **(+/-)**

- 5) Press the **ENT** key.
- 6) Press **▼**.
- 7) Enter estimated longitude within 10 degrees of actual position. Use the **+/-** key to switch coordinate from West to East and vice versa.

CLR ° ' **(+/-)**

- 8) Press the **ENT** key.
- 9) Press **▼** three times.

10) Enter height of antenna above the waterline in meters.

CLR **ENT**

Correct input of the antenna height above the waterline is essential for accurate determination of position. This data is used in 2D position fixing only.

11) Press the **SPD CRS** key. The GP-500 MARK-2 starts acquiring a satellite to fix its position. This takes from 15 to 45 minutes. 2D appears on the display when position fixing is completed.

NOTE: Do not change the setting of MASK ELEVATION (default setting 5°).

Selecting back-up navigator

GPS position fixes is available almost 24 hours a day from January 1993. Therefore, a back-up navigator is rarely needed. However, select the navigator which is to feed position information during no GPS position fixing as follows.

1) Press **MENU**, **9** and **3**. The BACK UP NAV SELECT display appears.

B A C K U P N A V S E L E C T										
→	B	A	C	U	P	N	A	S	E	L
→	BACK	UP	NAV	=	NONE					
				(1 : NONE	2 : GPDR	3 : NNDR	4 : LRN-A		
					5 : LRN-C	6 : OMG	7 : DEC	8 : I I	NAV)	
	GPS	POSN	CORRECT	=	NO	(1 : YES	0 : NO		
	GPS	COR	SMOOTHING	=	9	(0 ~ 9			
	GPS	CORRECT	VAR	:	0 . 000'	NO	. 000'	W		

Figure 8-7 BACK UP NAV SELECT display

2) Press **CLR**, and **ENT**.

- 1: No navigator connection. Your position is fixed (as long as three or four satellites are within line of sight) by GPS. When there is no GPS position fixing the position display freezes.
- 2: GPDR = Dead reckoning; log or gyrocompass
- 3: NNDR = Satellite navigator
- 4: LRN-A = Loran A
- 5: LRN-C = Loran C
- 6: OMG = Omega
- 7: DEC = Decca

3) Press .

4) Enter GPS position correction. Usually a constant difference exists between GPS and back-up navigator position fixes. This causes the position display to change when switching between GPS and back-up navigator.

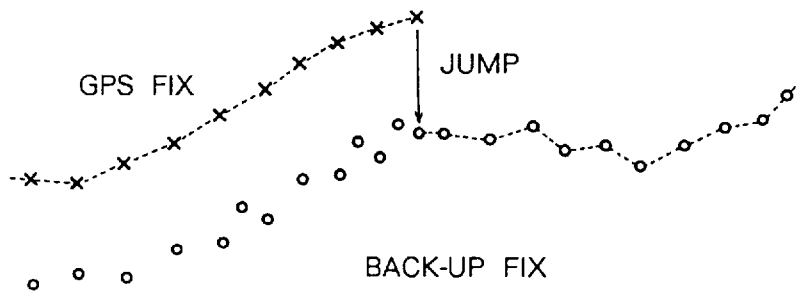

Figure 8-8 What happens to position display when switching from GPS to back-up navigator

The GPS fix is so more reliable than that of the back-up navigator, enter 1 (yes) to correct the back-up fix. Enter 0 for no correction.

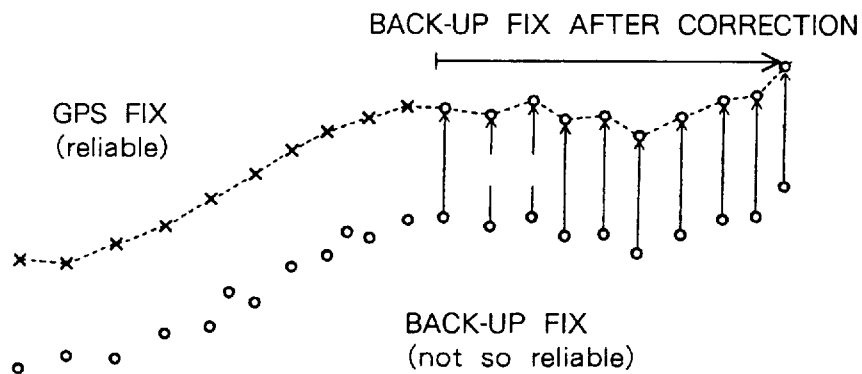

Figure 8-9 Effect of GPS position correction

5) Press .

6) Enter GPS position correction smoothing, if necessary. The correction, illustrated in Figure 8-17, is determined by averaging the differences between the GPS and back-up navigator position fixes. Enter the averaging period here.

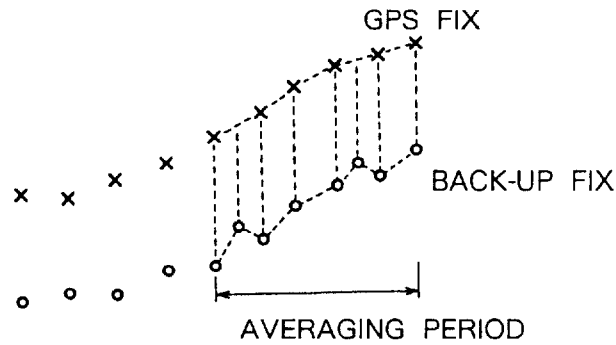

Figure 8-10 GPS correction smoothing

If the GPS or the back-up position is unstable, use a higher setting to get a longer averaging period. Enter 0 for no smoothing. For no smoothing, the correction value is given as the difference between the last GPS position fix and the back-up position fix at the time of the switching.

GPS correction value appears at the bottom of the display.

Selecting speed log and gyrocompass

If GPDR is selected as back-up navigator enable automatic or manual input of speed and heading data. (Manual input of speed and heading is necessary if you require the set and drift display.) If GPDR is selected but there is no log or gyrocompass see page 5-7 for further details.

1) Press **MENU**, **9** and **2**. The LOG GYRO display appears.

LOG • GYRO DATA		(▼ : GYRO)
→ LOG	= AUTO	(1 : AUTO 0 : MANUAL)
SPD	= LOG	(1 : LOG 0 : NMEA)
LOG IN	= CONTACT	(1 : CONTACT 0 : TTL)
LOG PULSE (IN)	=	200 P / NM (100 ~ 500 P / NM)
		(9000 ~ 30000 P / NM)
LOG PULSE (OUT)	=	0 P / NM (0 ~ 500 P / NM)

Figure 8-11 LOG GYRO DATA display (first page)

For speed log or external navigator connection;

2) Press **CLR**, **1** and **ENT** to select AUTO.

3) Press .

4) Select source of speed information.

1, log; 0, NMEA

If a navigator is connected to the DATA IN or DATA IN/OUT connector and outputs speed data (VHW) in NMEA 0183 format it can be used for dead reckoning.

5) Press .

6) Select signal type of speed log.

1, contact closure; 0, TTL level

7) Press .

8) Select log pulse ratio for input (pulses/nautical mile).

(100 to 500 or 9,000 to 30,000)

9) Press .

10) Select log pulse ratio for output.

(0 to 500)

You may output the speed signal (pulse signal) for external equipment measured by GPS. Enter 0 for no speed log output.

11) Press .

For gyrocompass or external navigator connection;

12) Press **CLR**, **1** and **ENT** to select AUTO.

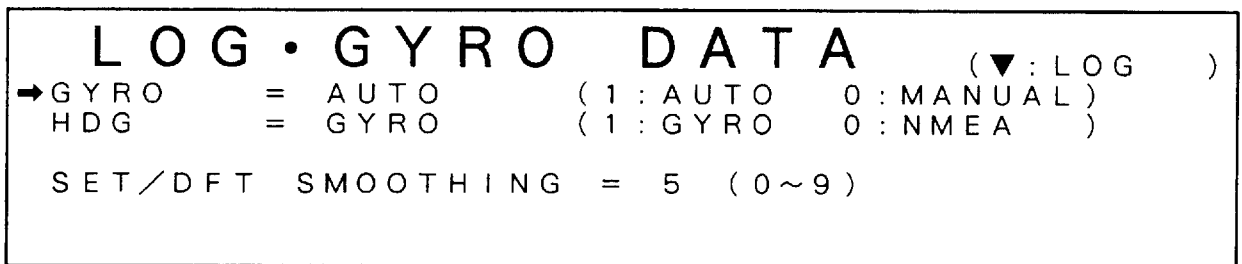

Figure 8-12 LOG GYRO DATA display (second page)

13) Press **▼**.

14) Enter source of heading information.

CLR **ENT**

1, gyro; 2, NMEA

If a navigator is connected to DATA IN or DATA IN/OUT connector and outputs heading data (VHW) in NMEA 0183 format it can be used in dead reckoning.

15) Press **▼**.

16) Enter set and drift smoothing.

CLR **ENT**

(0 to 9)

“5” is the standard setting.

Selecting communication format

Select communication format for DATA IN, DATA OUT, and DATA IN/OUT connectors. When you select a format for DATA IN, the same format is selected for DATA OUT, and vice versa.

NOTE: *The GP-500 MARK-2 can output and receive various data in CIF or NMEA format. When selecting format be sure the connected equipment is able to handle data to be output.*

DATA IN connector

This connector carries data from the back-up navigator. Note that this connector can also output autopilot information. More on this later.

- 1) Press **MENU**, **9**, **9** and **0**. The DATA IN CONNECTOR display appears.

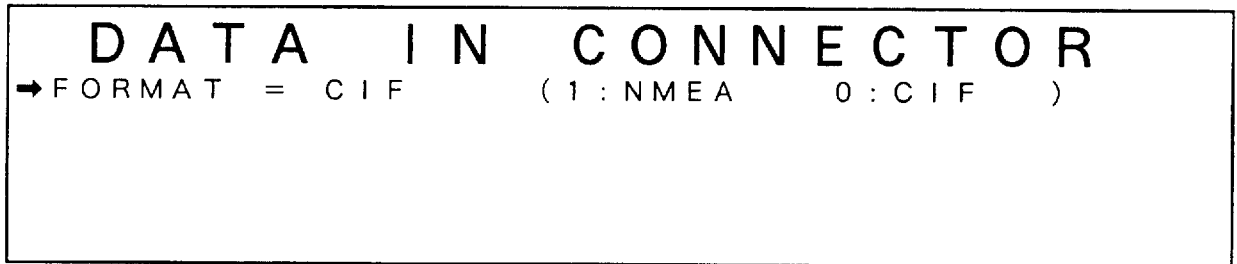

Figure 8-13 DATA IN CONNECTOR display

- 2) Select format.

CLR **ENT**

1, NMEA 0183; 0, CIF

The DATA IN connector can receive the following sentences:

FURUNO CIF: Present latitude, longitude, speed and course

NMEA 0183: GLL (present latitude and longitude), VHW (heading, water tracking speed) and VTG (course, ground tracking speed)

NOTE *VHW is required when GPDR is selected as back-up navigator and NMEA 0183 as speed and heading information source.*

DATA OUT connector

This connector is normally used to connect display devices such as plotter or video color sounder.

For CIF format;

- 1) Press **MENU**, **9**, **9** and **1**. The DATA OUT CONNECTOR display appears.

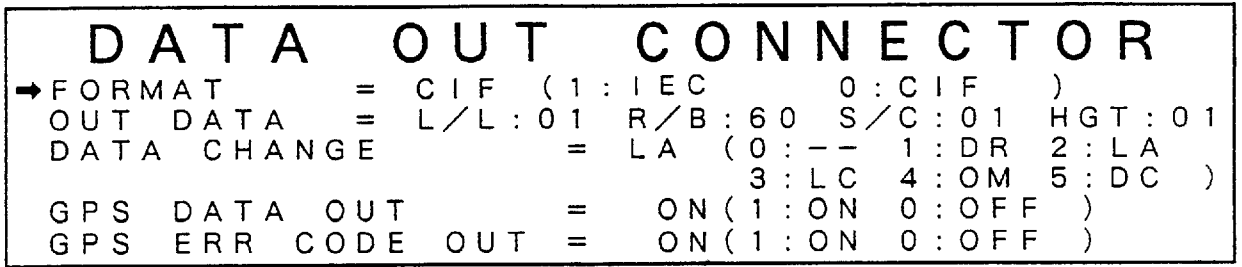

Figure 8-14 DATA OUT CONNECTOR display

2) Press **CLR**, **0** and **ENT** to select CIF.

3) Press **▼**.

4) Enter transmission interval (00, 01, 02, 03, 04, 05, 10, 12, 15, 20, 30, 40, 50, 60 or 90 seconds) for each of the following sentences. Enter 00 to disable transmission.

CLR **ENT**
└─┘ └─┘ └─┘ └─┘
L/L R/B S/C HGT

L/L ... latitude and longitude position

R/B ... range and bearing from present position to TO waypoint

S/C ... speed and course

HGT ... altitude obtained by 3-dimensional position fix

5) Press **▼**.

6) Select navigator for data (format) change.

CLR **ENT**

The GPS fix sentence is relatively new so some late model equipment may not recognize it. In this case both GPS and back-up position fixes may be transmitted in the format of a conventional navaid, one the external equipment recognizes. Select sentence as follows.

- 0: -- = GPS navigator
- 1: DR = Satellite navigator
- 2: LA = Loran A
- 3: LC = Loran C
- 4: OM = Omega
- 5: DC = Decca

7) Press .

8) Select how to output GPS data.

Enter 1 to transmit both GPS and back-up position fixes in GPS format and dummy format. For GPS format only, enter "0." at step 6 and "1" at this step.

9) Press .

10) Select whether to output GPS error code.

Enter 1 to transmit back-up position fix with GPS error code. Enter 0 to output original error code from back-up navaid. Normally, select 0.

For IEC 1162-1 format;

1) Press , , and . The DATA OUT CONNECTOR display appears.

GP: data format selected at previous page.

DATA OUT CONNECTOR				
→ FORMAT	=	IEC 1162 (1: IEC0: CIF)		GP 93%
INTERVAL	=	AAM: 04	APA: 00	APB: 00 BOD: 04
INTERVAL	=	BWC: 04	BWW: 00	GGA: 10 GLL: 01
INTERVAL	=	RMB: 00	RMC: 00	VDR: 10 VTG: 01
INTERVAL	=	WCV: 00	WNC: 00	WPL: 60 XTE: 04
INTERVAL	=	ZDA: 01	ZLZ: 00	ZTG: 00

Figure 8-15 DATA OUT CONNECTOR display

2) Press , and to select IEC.

3) Press .

4) Enter transmission interval for each of the following sentences.

└─┘ └─┘ └─┘ └─┘
 AAM APA APB BOD

Choose from 00, 01, 02, 03, 04, 05, 10, 12, 15, 20, 30, 40, 50, 60 and 90 seconds. Enter 00 for no transmission.

- 5) Repeat steps 3 and 4 to select transmission intervals for remaining sentences.

The TX rate of operation is the percentage of data output in one second, and it appears at the top right-hand corner on the screen. If short intervals are assigned to many sentences, the rate of operation increases as illustrated below.

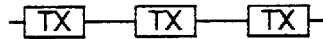

A rate of operation exceeding 100% is impractical. For better performance, the rate of operation should not exceed 93%, the default setting.

NOTE 1: *During back-up periods, sentences are transmitted with the talker ID "GP." However, the sentence contains error flags (for example, APA, XTE) to signify the position data is not by GPS. If there is no external navigator, speed and course information from dead reckoning are output during back-up periods.*

NOTE 2: *The GPS fix sentence is relatively new so some late model equipment may not recognize it. In this case both GPS and back-up position fixes may be transmitted in the format of a conventional navaid, one the external equipment recognizes. Select one as follows.*

- (1) Temporarily select CIF format by pressing at the DATA OUT CONNECTOR display (**MENU**, **9**, **9** and **1**). Select suitable talker on the DATA CHANGE line.

- 0: GP = GPS Navigator
(No transmission with a dummy format)
- 1: DR = Satellite navigator
- 2: LA = Loran A
- 3: LC = Loran C
- 4: OM = Omega
- 5: DC = Decca

- (2) Select IEC 1162-1 format.

If you do not need to change the talker name, temporarily select the CIF format and confirm that "0" is selected.

NOTE 3: *GPGLL (latitude and longitude) is output with the resolution of 0.001. The resolution level for other talkers is 0.01.*

NOTE 4: *The type of IEC 1162-1 and NMEA 0183 data which can be transmitted is as follows;*

IEC 1162-1 sentences

AAM: Arrival alarm

APB: Autopilot format B

BOD: Bearing to TO waypoint from FROM waypoint

BWC: Range and bearing to waypoint (great circle navigation)

BWW: Bearing to waypoint

GGA: GPS position fixing condition (time of fix, latitude, longitude, receiving condition, number of satellites used, DOP)

GLL: Latitude and longitude

RMB: Generic navigational information (cross track error, steering direction starting waypoint no., destination waypoint no., latitude and longitude of starting waypoint, latitude and longitude of destination waypoint, range and bearing to waypoint, range and bearing from present position to destination waypoint, velocity to destination, arrival alarm)

RMC: Generic navigational information (UTC time latitude, longitude, ground speed, true course, day, month, year)

VDR: Set and drift

VTG: Actual track and ground speed

WCV: Waypoint closure velocity

WNC: Range to TO waypoint in great circle

WPL: Waypoint position

XTE: Cross track error

ZDA: UTC, local zone time

ZTG: Time to go to waypoint

NMEA 0183 sentences

APA: Autopilot format A

ZLZ: UTC, day, month, year

DATA IN/OUT connector

This connector can receive RS-232C data and differential receiver data (RS-422) and output IEC 1162-1 data. It accepts display device or differential receiver.

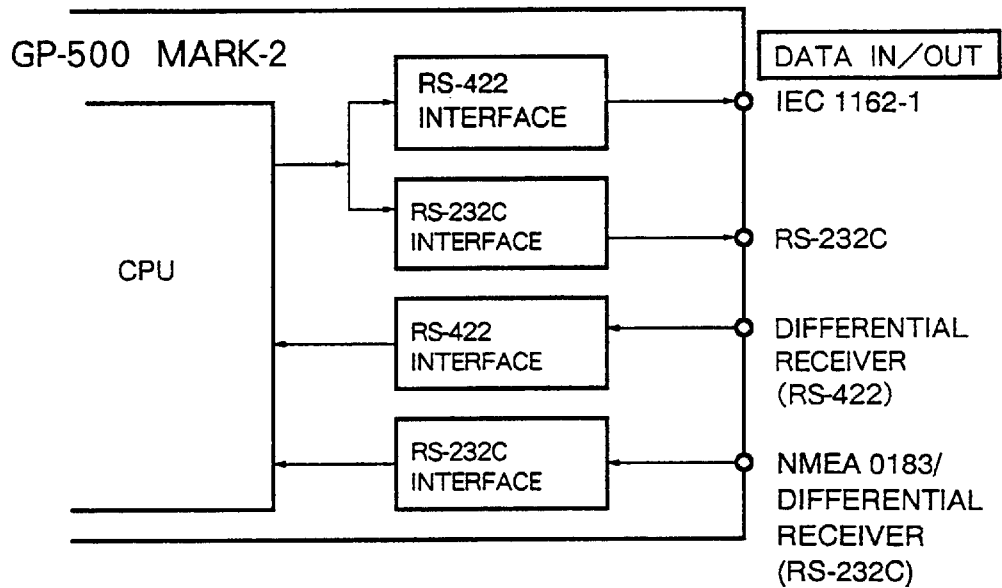

Figure 8-16 DATA IN/OUT connector

- 1) Press **MENU**, **9**, **9** and **2**. The D. IN/OUT CONNECTOR display appears.

D . I N / O U T C O N N E C T O R						
FORMAT	:	RS 2 3 2 C				9 3 %
→ INTERVAL	=	AAM : 04	APA : 00	APB : 00	BOD : 04	
INTERVAL	=	BWC : 04	BWW : 00	GGA : 10	GLL : 01	
INTERVAL	=	RMB : 00	RMC : 00	VDR : 10	VTG : 01	
INTERVAL	=	WCV : 00	WNC : 00	WPL : 60	XTE : 04	
INTERVAL	=	ZDA : 01	ZLZ : 00	ZTG : 00		

Figure 8-17 D. (ata)IN/OUT CONNECTOR display

- 2) Enter transmission interval for each of the following sentences.

CLR **ENT**

 AAM APA APB BOD

Choose from 00, 01, 02, 03, 04, 05, 10, 12, 15, 20, 30, 40, 50, 60 and 90 seconds. Enter 00 for no transmission.

- 3) Press **▼**.

4) Repeat steps 2 and 3 to select transmission intervals for remaining sentences.

NOTE 1: *All sentences transmitted with the talker ID "GP."*

NOTE 2: *GPGLL (latitude and longitude) is output with the resolution of 0.001.*

NOTE 3: *During back-up periods, sentences are transmitted with talker ID "GP." However, the sentence contains error flags (for example, APA, XTE) to signify the position data is not by GPS. If there is no external navigator, speed and course information from dead reckoning are output during back-up periods.*

NOTE 4: *RS-232C is the standard communication format. It mainly specifies electrical characteristics of signals and some handshake controls for data exchange. Sentences are prepared at the connected equipment (personal computer, etc.). The DTR output is inserted continuously; the DSR input is not available.*

Autopilot connection

An autopilot may be connected either to the #1 and #2 pins of DATA IN or the #3 and #4 pins of the DATA OUT. Any other device may also be connected to these pins.

For IEC 1162-1;

1) Press **MENU**, **9**, **9** and **3**. The AUTO PILOT DATA display appears.

A U T O P I L O T D A T A			
→ FORMAT	=	IEC (1 : IEC 1 1 6 2	0 : NMEA 1 8 0) 4 6 %
INTERVAL	=	AAM : 0 4	APA : 0 0 APB : 0 0 BOD : 0 4
INTERVAL	=	BWC : 0 4	BWW : 0 0 GGA : 0 0 GLL : 0 0
INTERVAL	=	RMB : 0 0	RMC : 0 0 VDR : 0 0 VTG : 0 4
INTERVAL	=	WCV : 0 0	WNC : 0 0 WPL : 0 0 XTE : 0 4
INTERVAL	=	ZDA : 0 0	ZLZ : 0 0 ZTG : 0 0

Figure 8-18 AUTO PILOT DATA display

2) Press **CLR**, **1** and **ENT** to select IEC 1162-1.

3) Press **▼**.

- 4) Enter transmission interval for each of the following sentences.

CLR ENT
 └──┬──┬──┬──┬──┬──┬──┬──┘
 AAM APA APB BOD

Choose from 00, 01, 02, 03, 04, 05, 10, 12 ,15, 20, 30, 40, 50, 60 and 90 seconds. Enter 00 for no transmission.

- 5) Repeat steps 3 and 4 to select transmission intervals for remaining sentences.

NOTE 1: All sentences transmitted with the talker ID “GP.”

NOTE 2: During back-up periods, sentences are transmitted with talker ID “GP.” However, the sentence contains error flags (for example, APA, XTE) to signify the position data is not by GPS. If there is no external navigator, speed and course information from dead reckoning are output during back-up periods.

For NMEA 0180:

- 1) Press MENU, 9, 9 and 3.

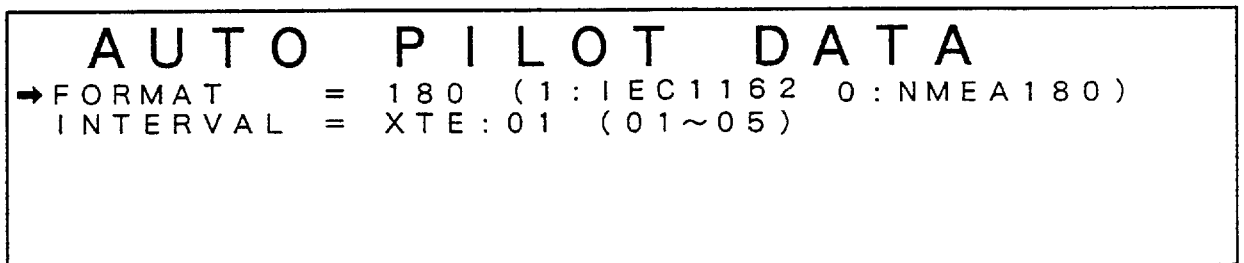

Figure 8-19 AUTO PILOT DATA display

- 2) Press CLR, 0 and ENT to select NMEA 0180.
- 3) Press ▼.
- 4) Enter transmission interval (01 to 05 seconds). Enter 00 for no transmission.

CLR ENT

Connecting DGPS Beacon Receiver

DGPS Beacon Receiver is connected to the terminal “DATA IN/OUT”. However pin numbers to be connected are different for signal levels RS-232C and RS-422.

1) When signal level of DGPS Beacon Receiver is RS-232C.

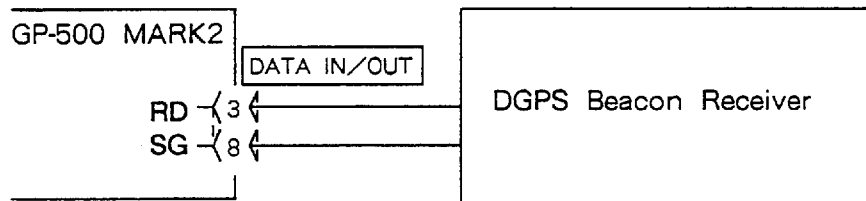

JP1 and JP2 on NAV Board are shorted in the factory setting.

2) When signal level of DGPS Beacon Receiver is RS-422.

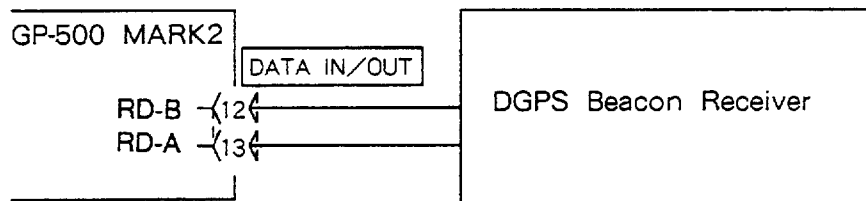

Remove jumper wires JP1 and JP2 on NAV Board.

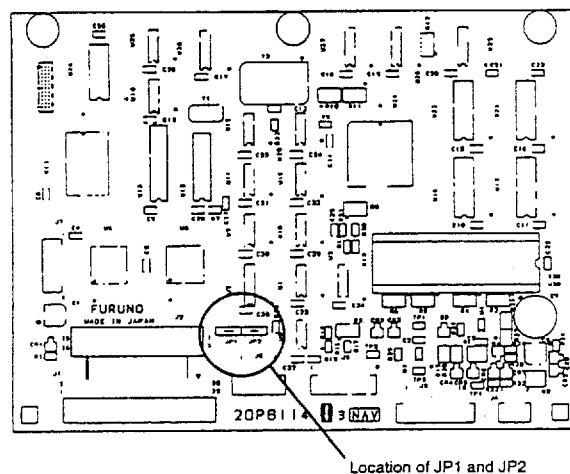
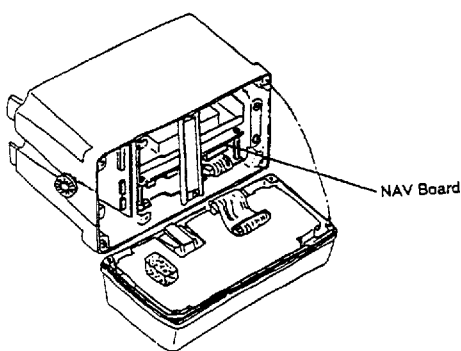

Interface documentation

“DATA IN” port

- NMEA 0183 Ver. 1.5/FURUNO CIF Sentence
- Input Schematic Diagram (Listener)

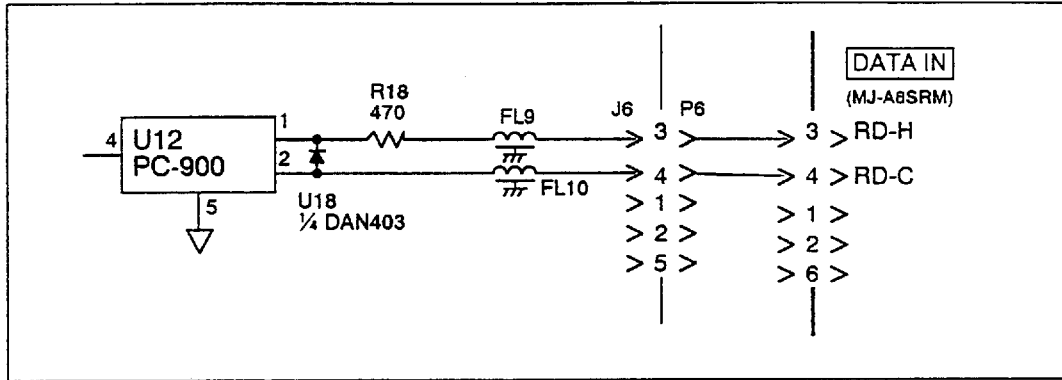

- Load requirements

Isolation: opto coupler

Input impedance: 470 ohm

Max voltage: ± 15 V

Threshold: 3mA

(In case of FURUNO device talker connection)

• Input Sentence List

NMEA 0183 Ver. 1.5 Sentence

Checksum is checked if attached and if any errors are found, the sentence becomes invalid.

GLL:Geographical position - latitude/longitude

\$--GLL, 3444.50,N,13521.30,E*23<CR><LF>

a b c d e

a:Latitude b:N/S c:Longitude d:E/W e:checksum

VTG:Course over ground and ground speed

\$--VTG, 123.0,T,130.0,M,23.4,N,43.3,K*12<CR><LF>

a b c d e f g h i

a,b:Course degrees true c,d:Course degrees magnetic e,f:Speed knots
g,h:Speed km/h i:checksum

VHW:Water speed and heading

\$--VHW, 123.0,T,130.0,M,10.0,N,18.5,K*34<CR><LF>

a b c d e f g h i

a,b:Heading, degrees true c,d:Heading, degrees magnetic e,f:Speed, knots
g,h:Speed, km/h i:checksum

FURUNO CIF Data

Latitude and longitude position

Speed and course

“DATA OUT” port

- IEC 1162-1/FURUNO CIF Sentence
- Output Schematic Diagram

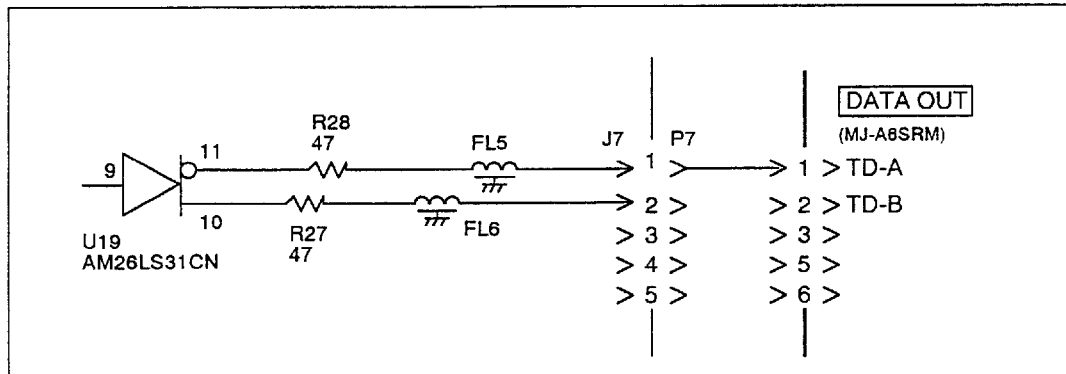

- Output drive capability
max 10mA
- IEC 1162-1 Output is subject to the standard of IEC 1162-1
First edition 1995-11.

• Output Sentence List

Each sentence is output at the interval entered.

IEC 1162-1

Cchecksum is attached to all sentences.

AAM: Waypoint arrival alarm

APB:Autopilot sentence B

"Heading to steer to destination waypoint data" is not used.

BOD:Bearing-origin to destination

BWC:Bearing and distance to waypoint-great circle

BWW:Bearing-waypoint to waypoint

GGA:Global positioning system (GPS) fix data

GLL:Geographic position-latitude/longitude

RMB:Recommended minimum navigation information

RMC:Recommended minimum specific GPS/TRANSIT data

VDR:Set and drift

VTG:Course over ground and ground speed

WCV:Waypoint closure velocity

WNC:Distance-waypoint to waypoint-great circle

WPL:Waypoint location

XTE:Cross-track error, measured

ZDA:Time and date

ZTG:UTC and time to destination waypoint

Also, following NMEA 0183 Ver. 1.5 sentences are output.

APA: Autopilot sentence "A" (Can be output in NMEA 0183 Ver. 1.5)

ZLZ: Time of day (Can be output in NMEA 0183 Ver. 1.5)

FURUNO CIF Data

Latitude and longitude position

Range and bearing from present position to destination waypoint

Speed and course

Altitude obtained by 3-dimensional position fix

“DATA IN/OUT” port

- IEC 1162-1 Sentence output
- Output Schematic Diagram (Talker)

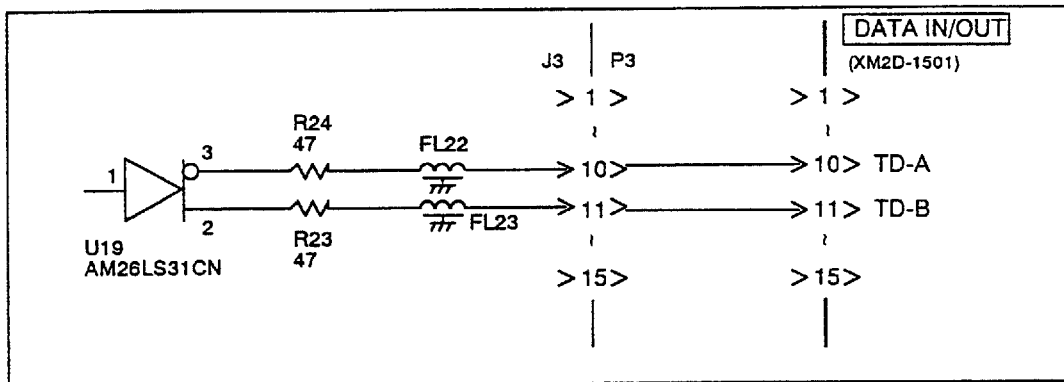

- Output drive capability
max. 10 mA
- IEC 1162-1 out is subject to the standard of IEC 1162-1 first edition 1995-11.
- The same sentence data is output from #2 and #8 of “DATA IN/OUT” port in RS-232C level.
- Output sentences same as that for “DATA OUT” port.

“Autopilot Data” Port

- IEC 1162-1 Sentence/NMEA 0180 Data Output
- Output Schematic Diagram (Talker)

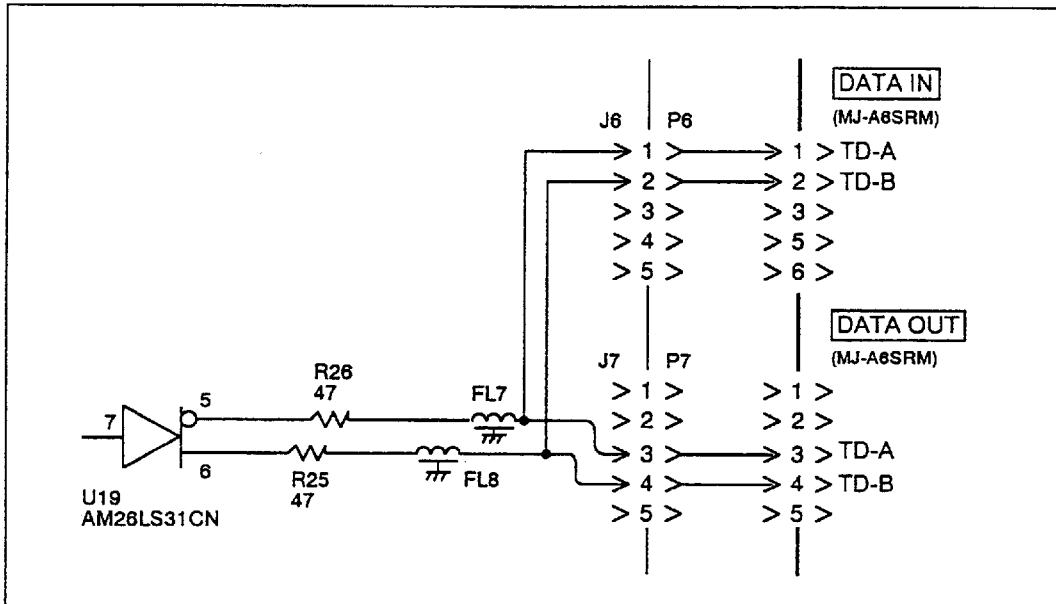

- Output drive capability
2 output total: max 10 mA
- IEC 1162-1 output is subject to the standard IEC 1162-1 first edition 1995-11.
- IEC 1162-1 output sentences are the same as that for “DATA OUT” port.

Specifications

ANTENNA UNIT

- | | |
|--------------------------------|--|
| 1) Number of Channels: | Eight channels parallel, eight satellite tracking ability |
| 2) Receiving Frequency: | 1575.42 MHz |
| 3) Receiving Code: | C/A Code |
| 4) Position Fixing Method: | All-in-view, 8-state Kalman filter |
| 5) Positioning Accuracy: | Approx. 50 m. 95% of the time,
Horizontal dilution of position (HDOP) ≤ 4 |
| | Note: All GPS receivers are subject to degradation of position and velocity accuracies under the U.S. Department of Defence. |
| | DGPS: Approx. 5 m, 95% of the time [Option] |
| 6) Tracking Velocity | 900 kts |
| 7) Satellite Acquisition Time: | Warm start, 20 seconds; Cold start, 2 minutes |
| 8) Position Update Interval: | Every second |

DISPLAY UNIT

- | | |
|-----------------------|---|
| 1) Display: | 240 x 64 dot matrix super twist LCD |
| 2) Illumination: | Backslid by EL Board |
| 3) Display Character: | alphanumeric characters |
| 4) Function: | (1) latitude and longitude (Loran A, C or Decca LOP also), (2) time, (3) speed, (4) course, (5) waypoint (up to 200), (6) event position (up to 20), (7) route (0 to 9), (8) range to waypoint, (9) bearing to waypoint, (10) time-to-go to destination, (11) cross track error, (12) estimated time of arrival to waypoint, (13) arrival and anchor watch alarms, (14) Cross track |

Specifications

error and border alarms, (15) ship's speed alarm, (16) trip alarm.

DATA I/O

- 1) Input Port: Speed log, gyrocompass, data in, one each
- 2) Output Port: Data out, one
- 3) Input/Output Port: One
- 4) Format: IEC 1162-1, CIF, NMEA 0183S, NMEA 0183

POWER SUPPLY & ENVIRONMENTAL CONDITIONS

- 1) Power Supply & Power Consumption: 10 V to 40 VDC, 12 W
- 2) Temperature: Antenna: -25 to +70 °C
Display: -15 to +55 °C
- 3) Humidity: 95% at 40 °C (both antenna and display units)
- 4) Watertightness: Antenna: waterproof
Display: Splashproof
- 5) Vibration: 1 to 12.5 Hz, 3.2 nm pp
12.5 to 25 Hz, 0.8 nm pp
25 to 50 Hz, 0.2 nm pp

DIMENSIONS & WEIGHT

- 1) Dimensions: Antenna: ϕ 52 x 290 mm
Display: 115 x 250 x 200 mm
- 2) Weight: Antenna: 0.5 kg
Display: 4 kg

Time Differences

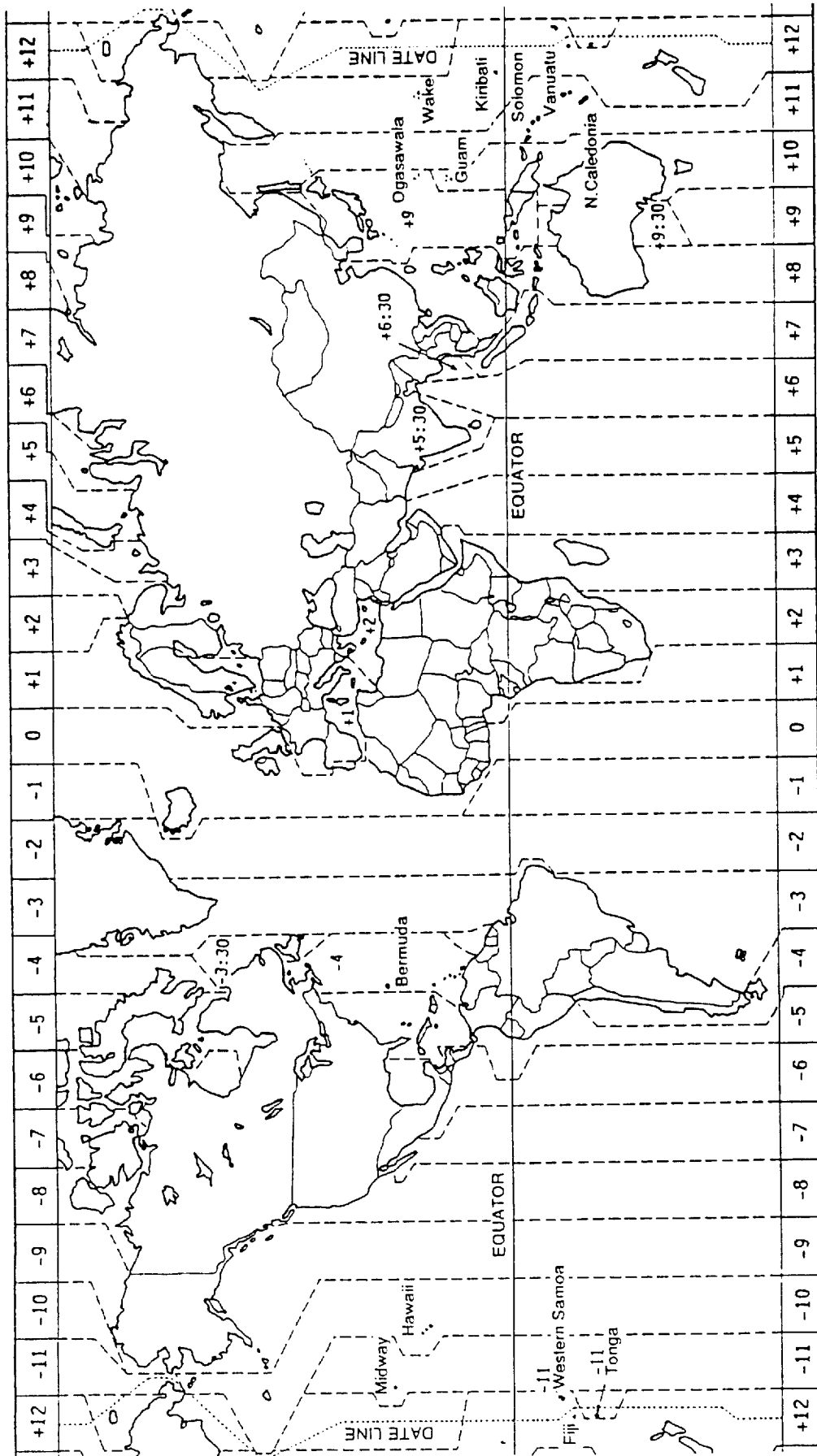

Geodetic Chart Systems

001 : WGS84		087 : MAPARIMA, BWI	: Trinidad and Tobago
002 : WGS72		088 : NORTH AMERICAN 1927	: Western United States
003 : TOKYO	: Mean Value (Japan, Korea, and Okinawa)	089 :	: Eastern United States
004 : NORTH AMERICAN 1927	: Mean Value (CONUS)	090 :	: Alaska
005 : EUROPEAN 1950	: Mean Value	091 :	: Bahamas (Excluding San Salvador Island)
006 : AUSTRALIAN GEODETIC 1984	: Australia and Tasmania Island	092 :	: Bahamas - San Salvador Island
007 : ADINDAN	: Mean Value (Ethiopia and Sudan)	093 :	: Canada (Including Newfoundland Island)
008 :	: Ethiopia	094 :	: Alberta and British Columbia
009 :	: Mali	095 :	: East Canada
010 :	: Senegal	096 :	: Manitoba and Ontario
011 :	: Sudan	097 :	: Northwest Territories and Saskatchewan
012 : AFG	: Somalia	098 :	: Yukon
013 : AIN EL ABD 1970	: Bahrain Island	099 :	: Canal Zone
014 : ANNA 1 ASTRO 1965	: Cocos Island	100 :	: Caribbean
015 : ARC 1950	: Mean Value	101 :	: Central America
016 :	: Botswana	102 :	: Cuba
017 :	: Lesotho	103 :	: Greenland
018 :	: Malawi	104 :	: Mexico
019 :	: Swaziland	105 : NORTH AMERICAN 1983	: Alaska
020 :	: Zaire	106 :	: Canada
021 :	: Zambia	107 :	: CONUS
022 :	: Zimbabwe	108 :	: Mexico, Central America
023 : ARC 1960	: Mean Value (Kenya, Tanzania)	109 : OBSERVATORIO 1966	: Corvo and Flores Islands (Azores)
024 :	: Kenya	110 : OLD EGYPTIAN 1930	: Egypt
025 :	: Tanzania	111 : OLD HAWAIIAN	: Mean Value
026 : ASCENSION ISLAND 1958	: Ascension Island	112 :	: Hawaii
027 : ASTRO BEACON "E"	: Iwo Jima Island	113 :	: Kauai
028 : ASTRO B4 SOR. ATOLL	: Tern Island	114 :	: Maui
029 : ASTRO POS 71/4	: St. Helena Island	115 :	: Oahu
030 : ASTRONOMIC STATION 1952	: Marcus Island	116 : OMAN	: Oman
031 : AUSTRALIAN GEODETIC 1966	: Australia and Tasmania Island	117 : ORDNANCE SURVEY OF GREAT BRITAIN 1936	: Mean Value
032 : BELLEVUE (IGN)	: Etata and Erromango Islands	118 :	: England
033 : BERMUDA 1957	: Bermuda Islands	119 :	: England, Isle of Man, and Wales
034 : BOGOTA OBSERVATORY	: Colombia	120 :	: Scotland and Shetland Islands
035 : CAMPO INCHAUSPE	: Argentina	121 :	: Wales
036 : CANTON ISLAND 1966	: Phoenix Islands	122 : PICO DE LAS NIVIES	: Canary Islands
037 : CAPE	: South Africa	123 : PITCAIRN ASTRO 1967	: Pitcairn Island
038 : CAPE CANAVERAL	: Mean Value (Florida and Bahama Islands)	124 : PROVISIONAL SOUTH CHILEAN 1963	: South Chile (near 53° S)
039 : CARTHAGE	: Tunisia	125 : PROVISIONAL SOUTH AMERICAN 1958	: Mean Value
040 : CHATHAM 1971	: Chatham Island (New Zealand)	126 :	: Bolivia
041 : CHUA ASTRO	: Paraguay	127 :	: Chile - Northern Chile (near 19° S)
042 : CORREGO ALEGRE	: Brazil	128 :	: Chile - Southern Chile (near 43° S)
043 : DJAKARTA (BATAVIA)	: Sumatra Island (Indonesia)	129 :	: Colombia
044 : DOS 1968	: Gizo Island (New Georgia Islands)	130 :	: Ecuador
045 : EASTER ISLANDS 1967	: Easter Island	131 :	: Guyana
046 : EUROPEAN 1950 (Cont'd)	: Western Europe	132 :	: Peru
047 :	: Cyprus	133 :	: Venezuela
048 :	: Egypt	134 : PUERTO RICO	: Puerto Rico and Virgin Islands
048 :	: England, Scotland, Channel, and Shetland Islands	135 : QATAR NATIONAL	: Qatar
050 :	: England, Ireland, Scotland, and Shetland Islands	136 : QORNOQ	: South Greenland
051 :	: Greece	137 : ROME 1940	: Sardinia Islands
052 :	: Iran	138 : SANTA BRAZ	: Sao Maguel, Santa Maria Islands (Azores)
053 :	: Italy - Sardinia	139 : SANTO (DOS)	: Espirito Santo Island
054 :	: Italy - Sicily	140 : SAPPER HILL 1943	: East Falkland Island
055 :	: Norway and Finland	141 : SOUTH AMERICAN 1969	: Mean Value
056 :	: Portugal and Spain	142 :	: Argentina
057 : EUROPEAN 1979	: Mean Value	143 :	: Bolivia
058 : GANDAJIKA BASE	: Republic of Maldives	144 :	: Brazil
059 : GEODETIC DATUM 1949	: New Zealand	145 :	: Chile
060 : GUAM 1963	: Guam Island	146 :	: Colombia
061 : GUX 1 ASTRO	: Guadalcanal Island	147 :	: Ecuador
062 : HJORSSEY 1955	: Iceland	148 :	: Guyana
063 : HONG KONG 1963	: Hong kong	149 :	: Paraguay
064 : INDIAN	: Thailand and Vietnam	150 :	: Peru
065 :	: Bangladesh, India, and Nepal	151 :	: Trinidad and Tobago
066 : IRELAND 1965	: Ireland	152 :	: Venezuela
067 : ISTS 073 ASTRO 1969	: Diego Garcia	153 : SOUTH ASIA	: Singapore
068 : JHONSTON ISLAND 1961	: Jhonston Island	154 : SOUTHEAST BASE	: Porto Santo and Madeira Islands
069 : KANDAWALA	: Sri Lanka	155 : SOUTHWEST BASE	: Faial, Graciosa, Pico, Sao Jorge, and Terceira Islands
070 : KERGUELEN ISLAND	: Kerguelen Island	156 : TIMBALAI 1948	: Brunel and East Malaysia (Sarawak and Sadah)
071 : KERTAU 1948	: West Malaysia and Singapore	157 : TOKYO	: Japan
072 : LA REUNION	: Mascarene Island	158 :	: Korea
073 : L.C. 5 ASTRO	: Cayman Brac Island	159 :	: Okinawa
074 : LIBERIA 1964	: Liberia	160 : TRISTAN ASTRO 1968	: Tristan da Cunha
075 : LUZON	: Philippines (Excluding Mindanao Island)	161 : VITI LEVU 1918	: Viti Levu Island (Fiji Islands)
078 :	: Mindanao Island	162 : WAKE-ENIWETOK 1960	: Marshall Islands
077 : MAHE 1971	: Mahe Island	163 : ZANDERIJ	: Suriname
078 : MARCO ASTRO	: Salvage Islands	164 : BUKIT RIMPAH	: Bangka and Belitung Islands (Indonesia)
079 : MASSAWA	: Eritrea (Ethiopia)	165 : CAMP AREA ASTRO	: Camp Mcmurdo Area, Antarctica
080 : MERCHICH	: Morocco	166 : G. SEGARA	: Kalimantan Islands (Indonesia)
081 : MIDWAY ASTRO 1961	: Midway Island	167 : HERAT NORTH	: Afghanistan
082 : MINNA	: Nigeria	168 : HU-TZU-SHAN	: Taiwan
083 : NAHRWAN	: Masirah Island(Oman)	169 : TANANARIVE OBSERVATORY 1925	: Madagascar
084 :	: United Arab Emirates	170 : YACARE	: Uruguay
085 :	: Saudi Arabia	171 : RT-90	: Sweden
086 : NAMIBIA	: Namibia		

Loran C/A Chain

Loran C Chain

CHAIN	GRI	S1	S2	S3	S4	S5
CENTRAL PACIFIC	4990	11	29	--	--	--
CANADIAN EAST COAST	5930	11	25	38	--	--
COMMANDO LION (Korea)	5970	11	31	42	--	--
CANADIAN WEST COAST	5990	11	27	41	--	--
SOUTH SAUDI ARABIA	7170	11	26	36	52	--
LABRADOR SEA	7930	11	26	--	--	--
EASTERN RUSSIA	7950	11	30	46	61	--
GULF OF ALASKA	7960	11	26	--	--	--
NORWEGIAN SEA	7970	11	26	46	60	--
SOUTHEAST U.S.	7980	11	23	43	59	--
MEDITERRANEAN SEA	7990	11	29	47	--	--
WESTERN RUSSIA	8000	10	25	50	65	--
NOTRH CENTRAL U.S.	8290	11	27	42	--	--
NORTH SAUDI ARABIA	8990	11	25	40	56	69
GREAT LAKES	8970	11	28	44	--	--
SOUTH CENTRAL U.S.	9610	11	25	40	52	65
U.S. WEST COAST	9940	11	27	40	--	--
NORTHEAST U.S.	9960	11	25	39	54	--
NORTHEAST PACIFIC	9970	11	30	55	81	--
ICELANDIC	9980	11	30	--	--	--
NORTH PACIFIC	9990	11	29	43	--	--

Loran A Chain

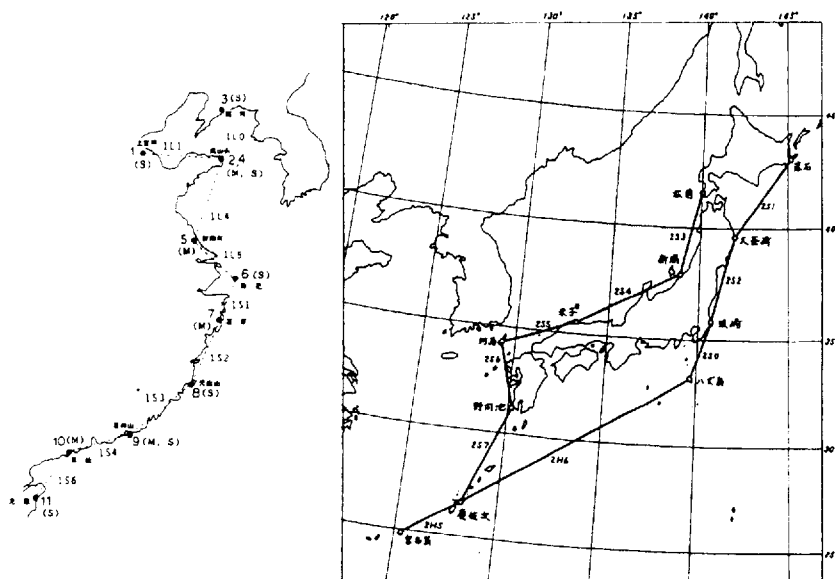

Decca Chains

No.	Chain	Chain Code	Area
01	SOUTH BALTIC	0A	Europe
02	VESTLANDET	0E	"
03	SOUTH WEST BRITISH	1B	"
04	NORTHUMBRIAN	2A	"
05	HOLLAND	2E	"
06	NORTH BRITISH	3B	"
07	LOFOTEN	3E	"
08		3E	"
09	NORTH BALTIC	4B	"
10	NORTH WEST	4C	"
11	TRONDELAG	4E	"
12	ENGLISH	5B	"
13	NORTH BOTHNIAN	5F	"
14	SOUTHERN SPANISH	6A	"
15	NORTH SCOTTISH	6C	"
16	GULF OF FINLAND	6E	"
17	DANISH	7B	"
18	IRISH	7D	"
19	FINNMARK	7E	"
20	FRENCH	8B	"
21	SOUTH BOTHNIAN	8C	"
22	HEBRIDEAN	8E	"
23	FRISIAN ISLAMDS	9B	"
24	HELGELAND	9E	"
25	SKAGERRAK	10B	"
26	NORTH PERSIAN GULF	5C	Persian Gulf & India
27	SOUTH PERSIAN GULF	1C	"
28	BOMBAY	7B	"
29	CALCUTTA	8B	"
30	BANGLADESH	6C	"
31	SALIYAH	2F	"
32	HOKKAIDO	9C	Japan
33	TOHOKU	6C	"

No.	Chain	Chain Code	Area
34	KANTO	8C	Japan
35	SHIKOKU	4C	"
36	HOKURIKU	2C	"
37	KITA-KYUSHU	7C	"
38	NAMAQUALAND	4A	Southrn Africa
39	CAPE	6A	"
40	EASTERN PROVINCE	8A	"
41	SOUTH WEST AFRICA	9C	"
42	NATAL	10C	"
43	DAMPIER	8E	Australia
44	PORT HEADLAND	4A	"
45	ANTICOSTI	9C	North America
46	EAST NEWFOUNDLAND	2C	"
47	CABOT STRAIT	6B	"
48	NOVA SCOTIA	7C	"

Equipment List

Complete Set





Name	Type	Qty	Wt.	Remarks	
Antenna Unit	GPA-014	1	0.5		
Display Unit	GPR-016	1	4		
Installation Materials	CP20-00900	1		For FSA	See next pages.
	CP20-00910			Except USA	
Spare Parts	SP20-00200	1 set			
Accessories	FP20-00200	1 set			

Optional Equipment

No.	Name	Type	Code No.	Remarks
1	Antenna Adaptor	OP20-14	000-040-235	for GPA-012
2	Rectifier	PR-62		for 110/220VAC
3	Antenna Cable Set	CP20-00600	000-040-670	30m
4	Antenna Cable Set	CP20-00610	000-040-671	50m
5	Flush Mount Kit	OP20-1	004-362-070	
6	Right Angle Mounting Base	No.13-QA300	000-803-239	
7	L-angle Mounting Base	No.13-QA310	000-803-240	
8	Variable Angle Mounting Base	No.13-QA100	000-803-241	
9	Modification Kit	OP20-21	000-040-238	for GP-500
10	Antenna Unit	GPA-012	000-040-218	
11	Antenna Unit	GPA-012-F	000-040-219	for FUSA

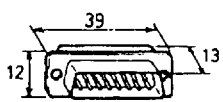
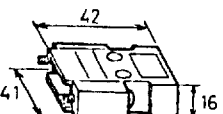
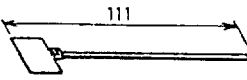
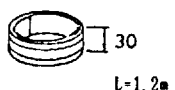
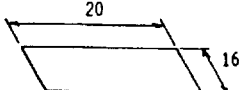
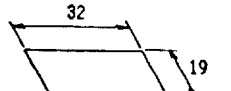
Equipment List



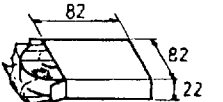
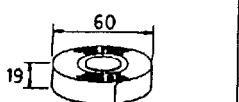

CODE NO	000-040-233	20AH-X-9401-1
TYPE	CP20-00900	

工事材料表 INSTALLATION MATERIALS		GP-500 MARK-2 GPS航法装置 GPS NAVIGATOR (FOR USA向)				
番号 No	名称 NAME	略図 OUTLINE	型名 / 規格 DESCRIPTIONS	数量 Q'TY	用途 / 備考 REMARKS	
CP20-00260 004-363-400	1	Dサブコネクタ D-SUB CONNECTOR	 XM2A-1501 CODE NO 000-111-706	1	受信部用 FOR MAIN UNIT	
	2	Dサブコネクタフート D-SUB CONNECTOR HOUSING	 XM2S-1513 CODE NO 000-118-820	1	受信部用 FOR MAIN UNIT	
	3	ケーブルバンド CABLE CLAMP	 PLF1M-M CODE NO 000-116-921	5	受信部用 FOR MAIN UNIT	
	4	アース銅板 COPPER STRAP	 04S40801 (30X1200X0.3) CODE NO 000-572-187	1	受信部用 FOR MAIN UNIT	
	5	ヒース貼りマーク LABEL	 20-004-8002-0 CODE NO 100-114-610	1	受信部用 FOR MAIN UNIT	
	6	ケーブル貼りマーク LABEL	 20-004-8003-0 CODE NO 100-114-820	1	受信部用 FOR MAIN UNIT	
	7	信号ケーブル組品 SIGNAL CABLE ASSY.	 MJ型6芯ケーブル付 コネクタ(EV-SA 7/0.16 X2P *5M*) CODE NO 000-117-603	4	受信部用 FOR MAIN UNIT	
	8	電源コード POWER CABLE	 22S0019 (VV0.75X2C *3M*) CODE NO 000-109-000	1	受信部用 FOR MAIN UNIT	
	CP20-00560 004-366-360	9	アンテナケーブル組品 ANTENNA CABLE ASSY.	 BBP-3D2V CODE NO 000-134-445	1	空中線部用 FOR ANT.UNIT
		10	絶縁テープ SELF-BONDING TAPE	 Uテープ 0.5X19X5M CODE NO 000-800-985	1	空中線部用 FOR ANT.UNIT
		11	ビニールテープNO.360 VINYL TAPE	 0.2X19X10000 黒 Iソソ BLK CODE NO 000-835-215	1	空中線部用 FOR ANT.UNIT

工事材料表 INSTALLATION MATERIALS		GP-500 MARK-2 GPS航法装置 GPS NAVIGATOR		20AH-X-9403-1	
		CODE NO	000-040-234		
		TYPE	CP20-00910		
番号 No	名称 NAME	略図 OUTLINE	型名 / 規格 DESCRIPTIONS	数量 Q'TY	用途 / 備考 REMARKS
CP20-00260 004-363-400	1 Dサブコネクタ D-SUB CONNECTOR		XM2A-1501 CODE NO 000-111-706	1	受信部用 FOR MAIN UNIT
	2 Dサブコネクタフート D-SUB CONNECTOR HOUSING		XM2S-1513 CODE NO 000-118-820	1	受信部用 FOR MAIN UNIT
	3 ケーブルバンド CABLE CLAMP		PLF1M-M CODE NO 000-116-921	5	受信部用 FOR MAIN UNIT
	4 アース銅板 COPPER STRAP		04S40801 (30X1200X0.3) CODE NO 000-572-187	1	受信部用 FOR MAIN UNIT
	5 ヒース貼りマーク LABEL		20-004-8002-0 CODE NO 100-114-610	1	受信部用 FOR MAIN UNIT
	6 ケーブル貼りマーク LABEL		20-004-8003-0 CODE NO 100-114-820	1	受信部用 FOR MAIN UNIT
	7 信号ケーブル組品 SIGNAL CABLE ASSY.		MJ型6芯ケーブル付 コネクタ(EV-SA 7/0.16 X2P *5M*) CODE NO 000-117-603	4	受信部用 FOR MAIN UNIT
	8 電源コード POWER CABLE		22S0019 (VV0.75X2C *3M*) CODE NO 000-109-000	1	受信部用 FOR MAIN UNIT
CP20-00550 004-366-350	9 アンテナケーブル組品 ANTENNA CABLE ASSY.		BBP-3D2V CODE NO 000-134-445	1	空中線部用 FOR ANT.UNIT
	10 パーカークランプ HOSE CLAMP		2672 SUS304 CODE NO 000-803-218	1	空中線部用 FOR ANT.UNIT
	11 取付補助具 INSTALLING SPACER		20-005-3101-0 CODE NO 100-150-540	1	空中線部用 FOR ANT.UNIT
	12 絶縁テープ SELF-BONDING TAPE		Uテープ 0.5X19X5M CODE NO 000-800-985	1	空中線部用 FOR ANT.UNIT
	13 ビニールテープNO.360 VINYL TAPE		0.2X19X10000 黒 Iソコ BLK CODE NO 000-835-215	1	空中線部用 FOR ANT.UNIT

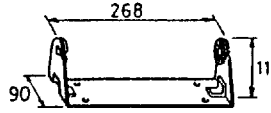
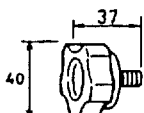
Equipment List

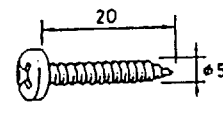
CODE No.	000-040-153	20AB-X-9501-3
TYPE	FP20-00200	

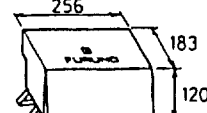
付属品表 ACCESSORIES		GP-500/500H GP-500 MARK-2	GPS航法装置 GPS NAVIGATOR		
番号 No.	名称 NAME	略図 OUTLINE	型名/規格 DESCRIPTIONS	数量 Q'TY	用途/備考 REMARKS
004-362-050 FP20-00200	1 ハンガー組品 HANGER BRACKET ASSY.		FP20-0210 N1.0 半寸 CODE No. 004-362-040	1	
	2 ノブボルト KNOB BOLT ASSY.		KG-B2 M8 x 20 SUS CODE No. 000-800-601	2	
	3 小型丸平座金 FLAT WASHER		M8 SUS304 CODE No. 000-800-917	2	
	4 ⊕ナベタッピンUIネジ TAPPING SCREW		5 x 20 SUS304 CODE No. 000-800-488	4	
	5 磨き平座金 FLAT WASHER		M5 SUS304 CODE No. 000-864-128	4	
	6 ビニールカバー VINYL COVER		20-004-2301-0 CODE No. 000-801-903	1	

CODE NO.	000-040-150	20AB-X-9301-4
TYPE	SP20-00200	BOX NO. P

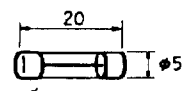
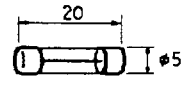
SHIP NO.	SPARE PARTS LIST FOR		U S E			SETS PER VESSEL
	GP-500/500H GP-500 MARK-2 GP-500H MARK-2	GPS航法装置 GPS NAVIGATOR				
ITEM NO.	NAME OF PART	OUTLINE	DWG NO. OR TYPE NO.	QUANTITY		REMARKS/CODE NO.
				WORKING	SPARE	
PER SET	PER VES.					
1	ミゼットヒューズ GLASS TUBE FUSE		FGMB 2A AC125V	1	3	000-103-165
2	ミゼットヒューズ GLASS TUBE FUSE		FGMB 3A AC125V	1	3	000-104-909

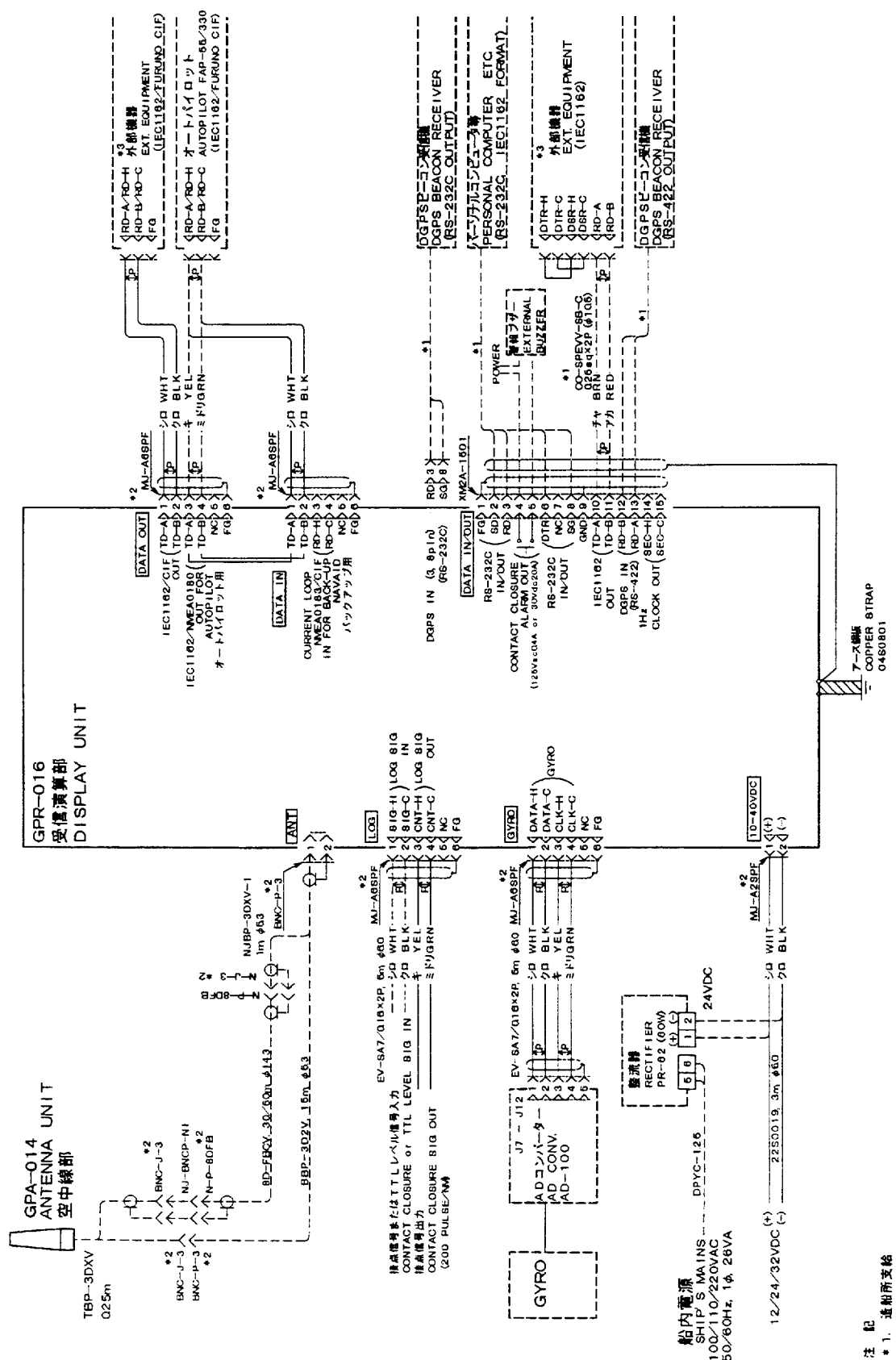

DRAWN	1979. 9. 17	T. YAMAZAKI	TITLE	GP-500 MARK-2
CHECKED		K. KIKUCHI	名 称	GPS 航法装置
APPROVED		Shiroji Yamaguchi		相互接続図
SCALE	1/4	MASS	NAME	GPS NAVIGATOR
				INTERCONNECTION DIAGRAM
			DWG No.	C4355-C01-G

注 記
 * 1. 造船所支給
 * 2. 工場にて接続済
 * 3. DTRとDSR端子が備わっているときは、それらも接続すること。

NOTE

- * 1. SHIPYARD SUPPLY
- * 2. FITTED AT FACTORY
- * 3 JUMP BETWEEN DTR AND DSR IF PROVIDED

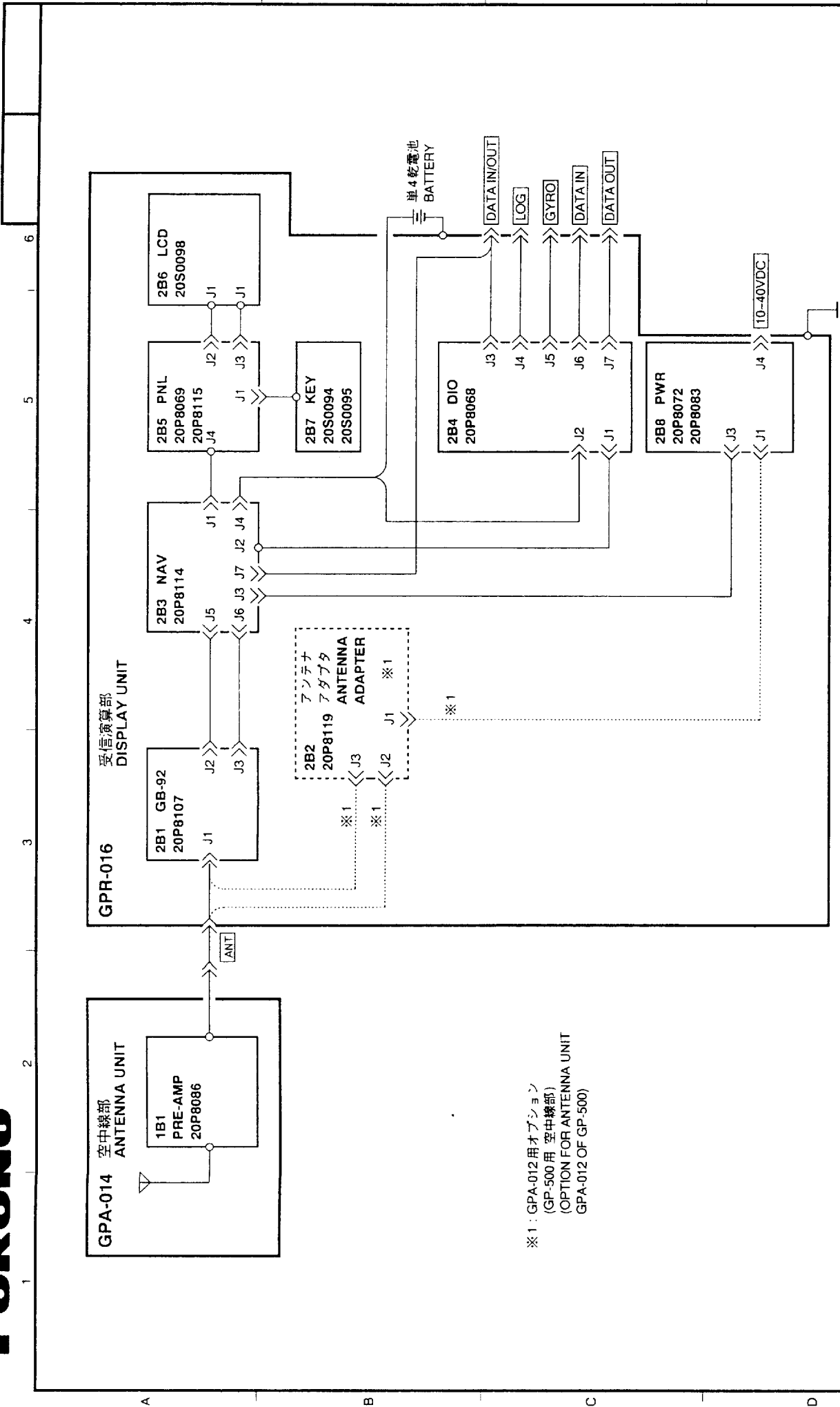

※1: GPA-012用オプション
(GP-500用 空中線部)
(OPTION FOR ANTENNA UNIT
GPA-012 OF GP-500)

品番 ITEM	品名 NAME	材質 MATERIAL	数量 QTY	図番 DWG. NO.	備考 REMARKS
承認 APPROVED	Jan. 29 '93				
検図 CHECKED	M. / KEOA				
製図 DRAWN	JAN. 29 '93				
製図 DRAWN	TAPAI-A SHI				
品名 TITLE	総合回路図 GENERAL SCHEMATIC				
図番 DWG. NO	GP-500 MARK 2 DIAGRAM				
重量 WEIGHT	kg				
重量 WEIGHT	C4355-K01-A				

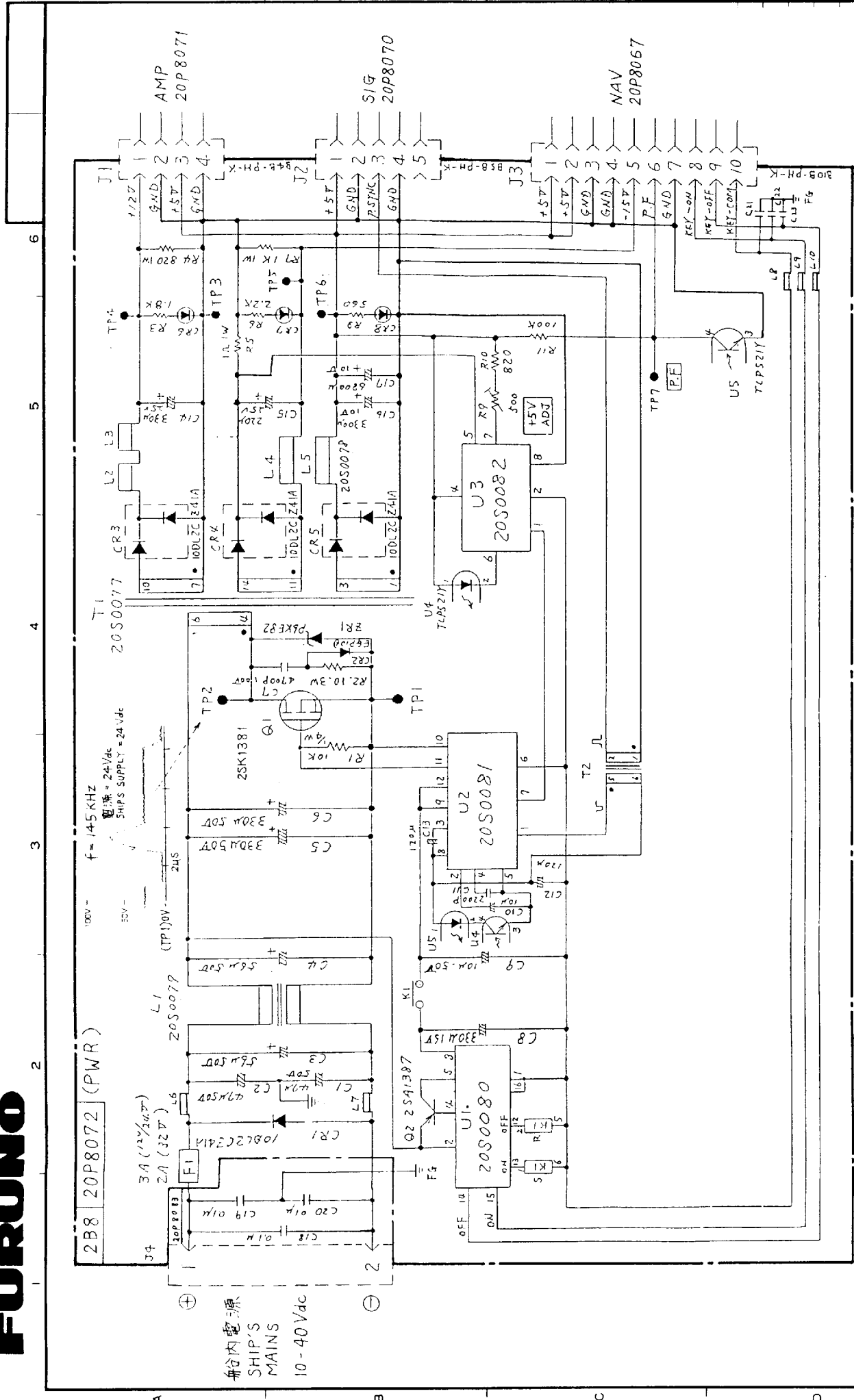

承認	NOV. 8 '89	名	額
APPROVED	T. UAKA	U.C.	TITLE
検	NOV. 8 '89		
CHECKED	N. S. A. I. T. O.		
製	NOV. 8 '89		
DRAWN	T. YUJAMA		

2B8 20P8072 (PWR)
 3A (12/20W)
 2A (32V)
 100V 10W
 24Vdc
 24Vdc SHIPS SUPPLY
 f = 145 KHz
 電圧 = 24Vdc
 SHIPS SUPPLY = 24Vdc

船内電源
 SHIP'S
 MAINS
 10-40 Vdc

AMP
 20P8071

SIG
 20P8070

NAV
 20P8067

20P8072
 PWR 基板
 PWR BOARD
 C4312 - K01 - B
 GP-500
 GP-500 MARK-2

1) FIXED TO MAST

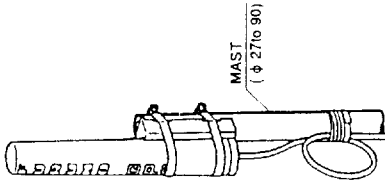
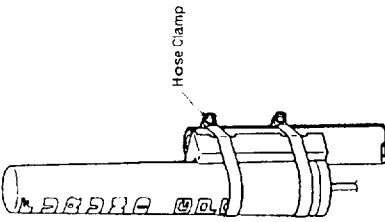
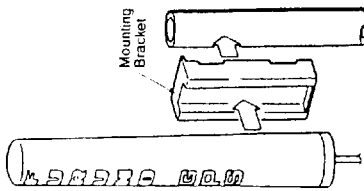

Mounting Bracket

Hose Clamp

MAST
(ϕ 27 to 90)

After connecting antenna cable, waterproof the connector by wrapping it with self-bonding tape and then vinyl tape.

Tape antenna cable to mast as shown above.

2) SCREWED INTO THREADED PIPE

Thread Type	Threads per 25.4 mm (1 inch)	Pitch	Pitch Diameter
1 x 14 UNS	14	1.8143	24.15

After connecting antenna cable, waterproof the connector by wrapping it with self-bonding tape and then vinyl tape.

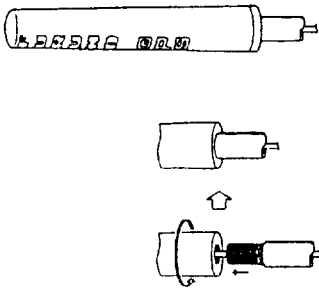

3) RIGHT ANGLE MOUNTING BASE (Option)

Type No. 13-QA300, Code No. 000-803-239

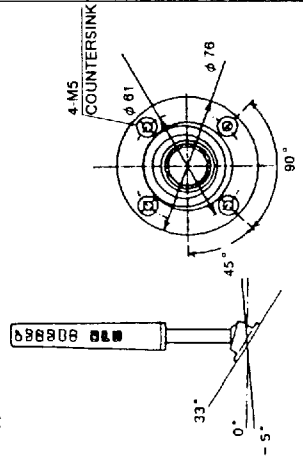

4) L-ANGLE MOUNTING BASE (Option)

Type No. 13-QA310, Code No. 000-803-240

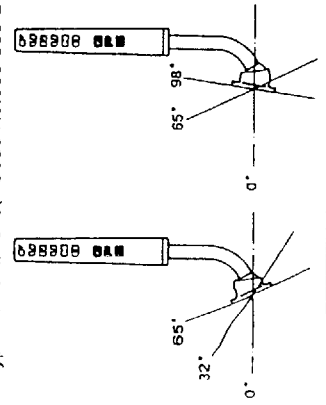

Mounting location

The figure below shows the recommended separation distances from other antennas to avoid mutual interference.

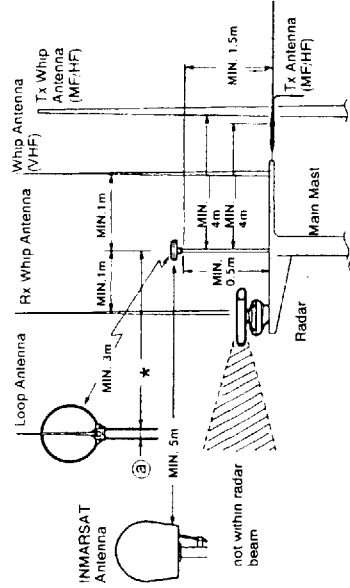

* Distance depends on mast diameter of ③
 ③ mast diameter 10cm : minimum 1.5m
 ④ mast diameter 30cm : minimum 3m

5) VARIABLE ANGLE MOUNTING BASE

Type No. 13-QA100, Code No. 000-803-241

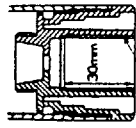
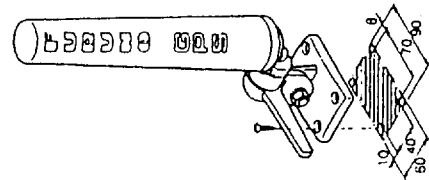

WHITWORTH FINE THREAD W25-14

NOTE: Substitutable with UNIFY THREAD (1-14 UNS).

ANTENNA UNIT
GPA-014

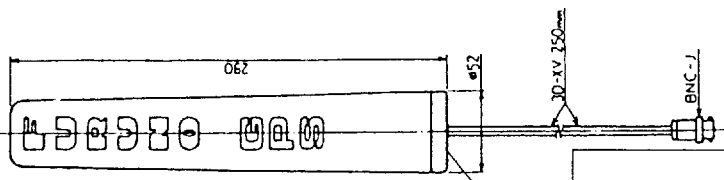

REMARKS	TYPE	NAME	INSTALLATION DIAGRAM
GP188	GPA014		
GP3100			
GP500MK2			
GP700MK2			
APPLICABLE TO:			
(MODEL)			
DRAWN : APPROVED			
E.M. SCALE			
MASS	kg		
BLOCK NO.			
FIG. NO.			

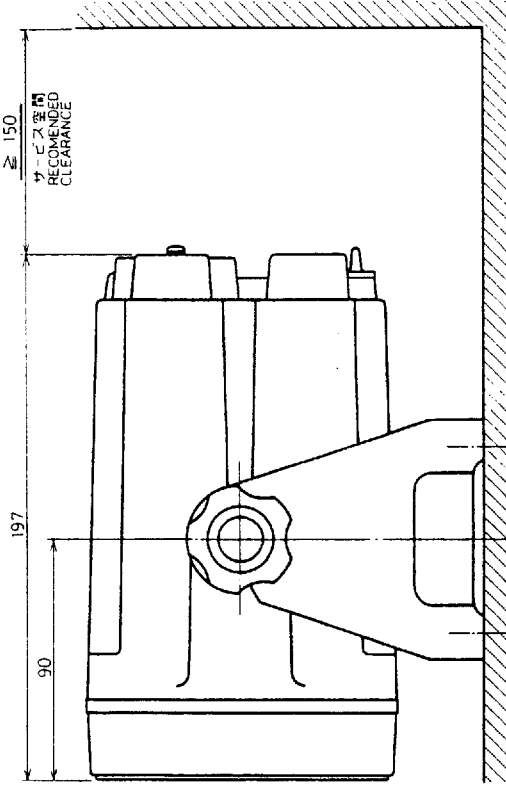
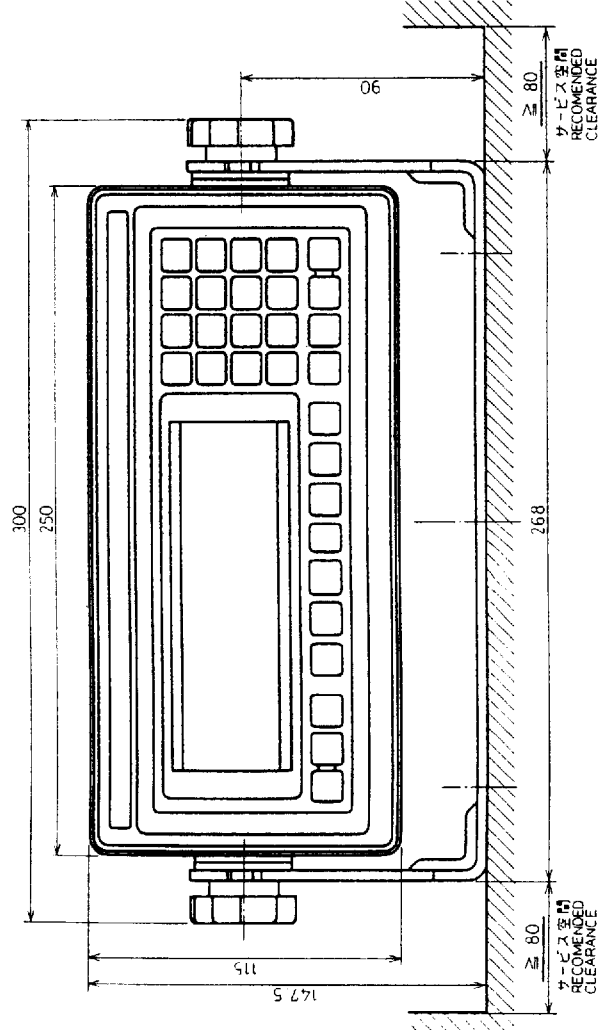
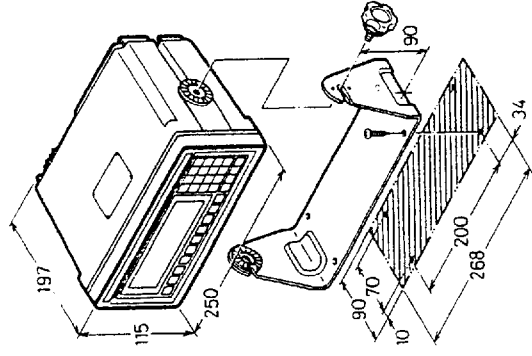
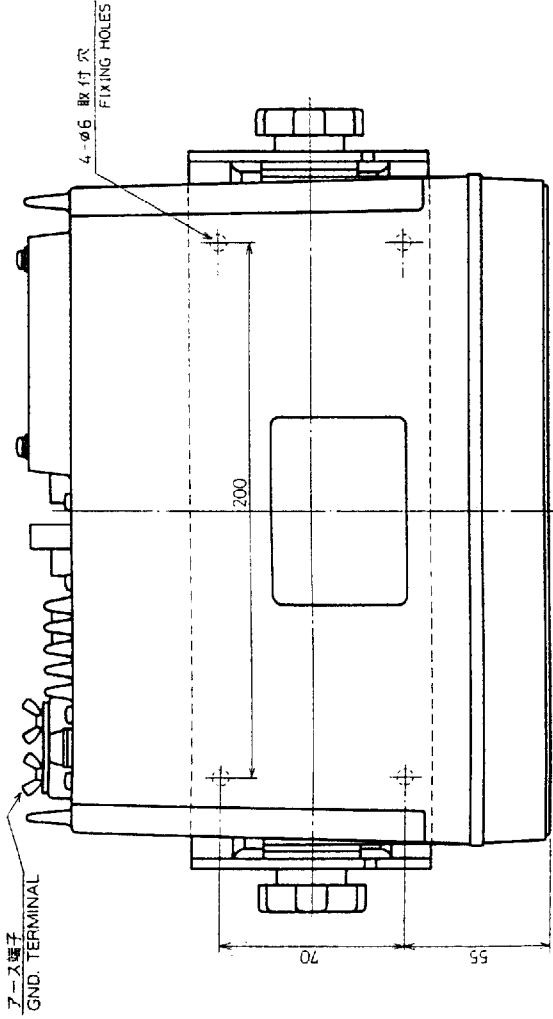

マージン空間
RECOMMENDED
CLEARANCE

マージン空間
RECOMMENDED
CLEARANCE

承認 APPROVED	品番 ITEM	品名 NAME	材質 MATERIAL	数量 QTY	図番 DWG. NO.	備考 REMARKS
JUL. 26. 37						
T. NAKANO						
JUL. 26. 8P						
T. YUYAMA						
JUL. 25. 37						
A. SAIIC						
	THIRD ANGLE PROJECTION	名称 TITLE				
	R 角度 SCALE	GPR-016				受信演算部外形図
	1/2	GPR-013				MAIN UNIT
	重量 WEIGHT	4 kg				C4312-G01-D

GP-500 MARK 2

GP-500

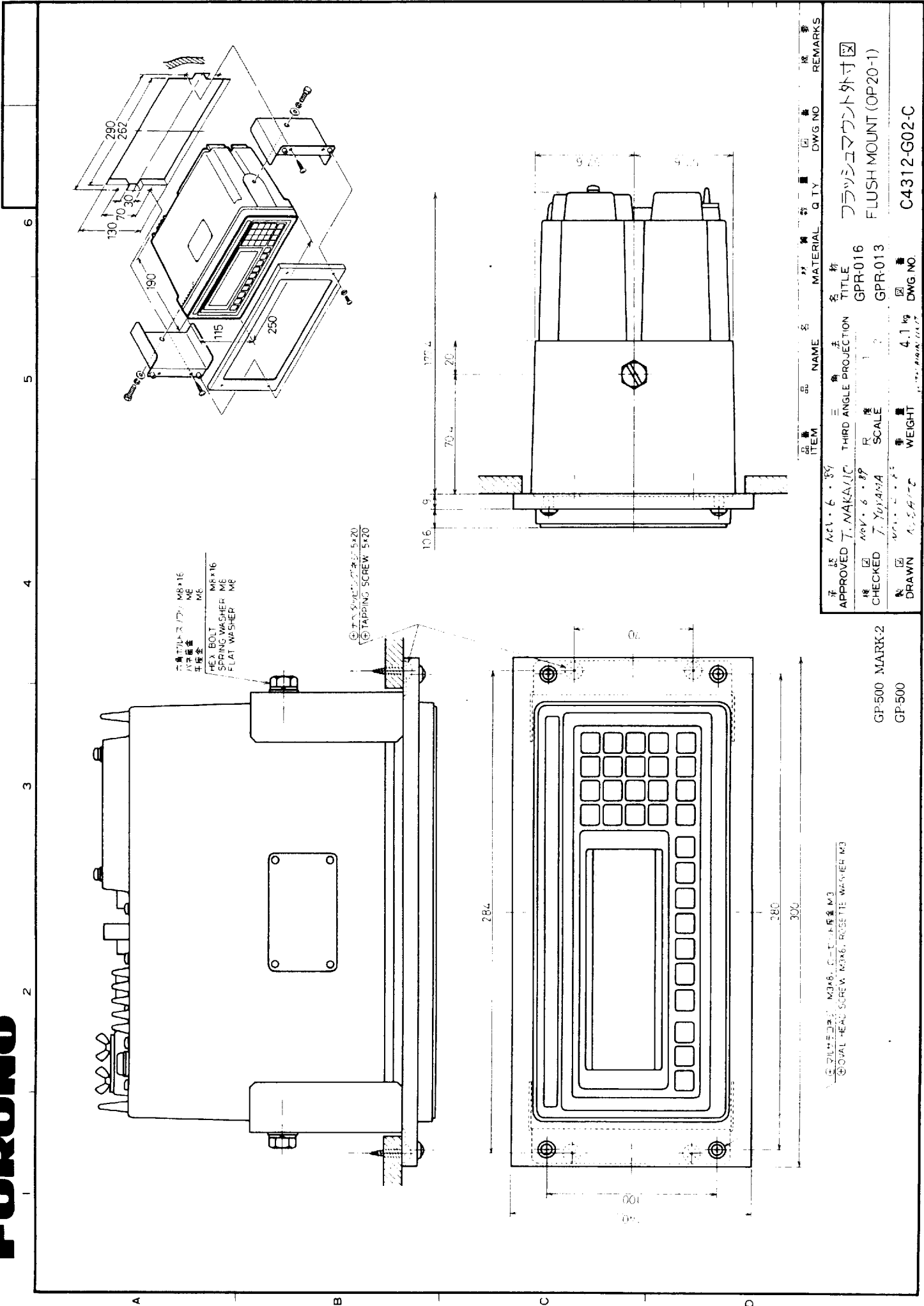

ITEM	NAME	MATERIAL	Q.TY	DWG NO	REMARKS
承認	APPROVED	T. NAKAJIC			
検査	CHECKED	T. YOSHIDA			
製図	DRAWN	A. SAITO			
品名	名称	材料	数量	図番	備考
GP-500 MARK-2	GP-500 MARK-2				
GP-500	GP-500				
第三角投影	THIRD ANGLE PROJECTION				
縮尺	SCALE				
重量	WEIGHT	4.1 kg			
社名	会社名	株式会社 富士通			
図名	TITLE	フラッシュマウント外寸図			
図番	DWG NO.	GPR-016			
図番	DWG NO.	GPR-013			
図番	DWG NO.	C4312-G02-C			

A

Abbreviations on — screen, 2-13

Alarms

- anchor watch alarm description, 6-5
- arrival alarm description, 6-5
- border alarm description, 6-6
- cross track error alarm description, 6-5
- selecting stopwatch, 6-2
- selecting timer, 6-2
- setting anchor watch alarm, 6-6
- setting arrival alarm, 6-6
- setting border alarm, 6-7
- setting cross track error alarm, 6-7
- setting ship's speed alarm, 6-8
- setting trip, 6-8
- setting audible alarm, 6-8
- starting stopwatch, 6-3
- starting timer, 6-4

Almanac

- displaying time received, 7-11
- receiving, 7-11

Anchor watch alarm

- description, 6-5
- setting, 6-6

Antenna unit height, 2-9

Arrival alarm

- description, 6-5
- setting, 6-6

B

Border alarm

- description, 6-6
- setting, 6-7

C

Calculate

- range and bearing between two wpts, 3-17
- time-to-go between two waypoints, 3-16
- TTG and ETA between two points, 3-19

Cancel

- destination waypoint, 3-10
- route navigation, 4-11

Clear

- navigation data (incl. waypoints), 7-9
- navigation data plus system data, 7-9
- wrong data, 2-2

Cold start, 7-11

Course error

- discription, 3-14

Cross track error

- description, 3-14
- graphic display, 3-11

Cross track error alarm

- description, 6-5
- setting, 6-7

D

Decca

- entering and displaying position, 5-14
- entering manual LOP offset corrections, 5-15
- list of chains, A-6

Default setting, 5-20

Delete

- point from a route, 4-9
- waypoint position information, 3-10
- route contents, 4-3

Destination waypoint

- canceling, 3-10
- cross track error to, 3-14
- range and bearing to, 3-13
- selecting, 3-9

Differential GPS

- initial setting, 5-17
- data receiving status, 5-19
- connecting DGPS receiver, 8-20

Display

- course error, 3-14
- cross track error, 3-14
- distance run, 3-16
- DOP, noise level, 7-4

- position in Decca LOPs, 5-14
- position in Loran A TDs, 5-13
- position in Loran C TDs, 5-12
- program version no., 7-6
 - range and bearing to destination waypoint, 3-13
- satellite receiving status, 7-4
- satellite schedule, 7-5
- satellite signal level, 7-4
- time almanac received, 7-11
- waypoint list, 3-7

DOP, 1-2

Drift, 3-15

E

Enter

- antenna unit height, 2-9
- automatic magnetic variation, 5-4
- data, 2-6
- Decca chain, 5-14
- elevation angle, 2-9
- estimated position, 2-8
- geodetic chart correction value, 5-2
- Loran A chain, 5-13
- Loran C chain, 5-12
- manual Decca LOP offset corrections, 5-14
- manual magnetic variation, 5-4
- manual Loran TD position offset corrections, 5-14
- smoothing, 5-10
- waypoint by L/L, Loran TDs, or Decca LOPs, 3-2

Equipment list, A-7

G

Geodetic chart

- entering correction value, 5-9
- selecting, 5-2
- systems stored in this unit, A-4

GPS

- accuracy, 1-2
- almanac, 1-5
- description, 1-1
- how receiver finds its position, 1-1

I

- entering estimated position, 8-6
- selecting back-up navigator, 8-7
- selecting CIF format, 8-12
- selecting NMEA0180S format, 8-19
- selecting NMEA0183 format, 8-14, 8-18
- selecting speed log and gyrocompass, 8-9

K

Keyboard, 2-2

- basic operating procedures, 2-4
- response conventions, 2-3
- testing, 7-8

L

Loran A

- entering and displaying position, 5-13
- entering manual TD offset corrections, 5-14
- list of chains, A-5

Loran C

- entering and displaying position, 5-12
- entering manual TD offset corrections, 5-14
- list of chains, A-5

M

Magnetic variation

- automatic, 5-4
- manual, 5-4

Memory

- clearing navigation data, 7-9

P

- Position — fixing mode selection, 2-9
- Present position
 - converting to waypoint, 3-5
 - saving, 2-15
- Program version no., 7-6

R

- Range and bearing calculation between two waypoints, 3-17
- key, 2-2
- Recalling saved position, 2-17
- Route navigation
 - canceling, 4-11
 - connecting routes, 4-10
 - creating a route, 4-2
 - deleting route contents, 4-3
 - following a route, 4-8
 - registering route “00”, 4-5
 - selecting a route, 4-8
 - temporarily deselecting a point on a route, 4-9

S

- Satellite
 - deselecting/reselecting, 5-15
 - displaying DOP, noise level, 7-4
 - displaying receiving status, 7-4
 - displaying schedule, 7-5
 - displaying signal level, brg, elevation angle, 7-4
 - entering mask elevation angle, 2-9
- Saved position
 - converting to waypoint, 3-5
 - recalling, 2-17
- Saving present position, 2-15
- Self test, 7-6
- Set, 3-15
- Ship’s speed alarm
 - description, 6-6
 - setting, 6-8
- Smoothing, 5-10
- Specifications, A-1
- Standard display, 2-11

T

- Time differences map, A-3
- Time-to-go, 3-16
- Trip alarm
 - description, 6-6
 - setting, 6-8
- Troubleshooting
 - displaying program version no., 7-6
 - displaying sat. DOP, noise level, 7-4
 - displaying sat. sig. level, brg, elev. angle, 7-4
 - displaying time almanac received, 7-11
 - executing cold start, 7-11
 - keyboard/LCD test, 7-8
 - self test, 7-6
 - troubleshooting example, 7-2

U

- Units of measurement, 5-5

V

- Velocity to destination description, 3-12

W

- Waypoint
 - calculating r/b between two waypoints, 3-17
 - calculating time-to-go, 3-16
 - canceling destination waypoint, 3-10
 - clearing all, 7-9
 - entering by L/L, Loran TDs, Decca LOPs, 3-2
 - entering by present position, 3-5
 - entering by previously saved position, 3-5
 - selecting destination waypoint, 3-9
 - waypoint list, 3-7
 - write-protecting waypoints, 3-4

FURUNO**FURUNO ELECTRIC CO., LTD.**

9-52 Ashihara-Cho, Nishinomiya City, 662-8580, Hyogo, Japan

Tel: +81 798-65-2111 Fax: +81 798-65-4200

Pub NO. DOC-229

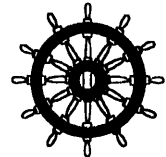
Declaration of conformity to typeWe **FURUNO ELECTRIC CO., LTD.**-----
(Manufacturer)

9-52 Ashihara-Cho, Nishinomiya City, 662-8580, Hyogo, Japan

(Address)

hereby declare under our sole responsibility that the product

Marine GPS navigator model GP-500 MARK-2 consisting of Display unit GPR-016 and Antenna unit GPA-014

(Model names, type numbers)

to which this declaration relates conforms to the following standard(s) or normative document(s)

EN 61108-1: June 1996 (IEC 61108-1: 1996-06)

EN 61162-1: November 1995 (IEC 61162-1: 1995-11)

EN 60945: January 1997 (IEC 60945 Third edition: 1996-11)

(title and/or number and date of issue of the standard(s) or other normative document(s))

For assessment, see EC type-examination certificate N° KCS/99212017/AA/00 of 3 June 1999 issued by KCS Certification, The Netherlands

This declaration is issued according to the provisions of European Council Directive 96/98/EC on marine equipment modified by Commission Directive 98/85/EC.

On behalf of Furuno Electric Co., Ltd.

Hiroaki Komatsu
Manager,
International Rules and RegulationsNishinomiya City, Japan
June 16, 1999-----
(Place and date of issue)-----
(name and signature or equivalent marking of authorized person)